



LC72135M

PLL Frequency Synthesizer for Electronic Tuning



Overview

The LC72135M is a PLL frequency synthesizer LSI for tuners in car stereo and similar applications. High-performance AM/FM tuners can be easily implemented with this product.

Functions

- High-speed programmable dividers
 - FMIN: 10 to 160 MHzpulse swallower
(built-in divide-by-two prescaler)
 - AMIN: 2 to 40 MHzpulse swallower
0.5 to 10 MHzdirect division
- IF counter
 - HCTR 0.4 to 12 MHzAM/FM IF counter
 - LCTR 100 to 500 k Hz.....AM IF counter
- Reference frequencies
 - Twelve selectable frequencies
(4.5 or 7.2 MHz crystal)
1, 3, 5, 9, 10, 3.125, 6.25, 12.5, 15, 25, 50 and 100 kHz
- Phase comparator
 - Dead zone control
 - Unlock detection circuit
 - Deadlock clear circuit
- Built-in MOS transistor for forming an active low-pass filter
- I/O ports
 - Dedicated output ports: 4
 - Input or output ports: 1
 - Input ports (LCTR) : 1
 - Support clock time base output
- Serial data I/O
 - Support CCB format communication with the system controller.
- Operating ranges
 - Supply voltage.....4.5 to 5.5 V
 - Operating temperature.....-40 to +85°C
- Package
 - MFP20

Package Dimensions

unit: mm

3036B-MFP20

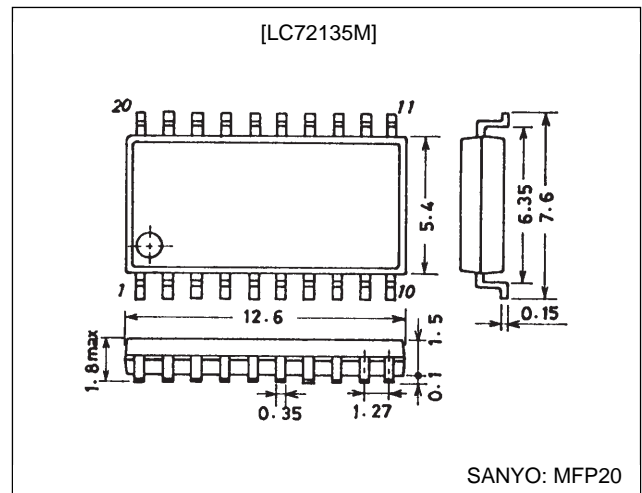

- CCB is a trademark of SANYO ELECTRIC CO., LTD.
- CCB is SANYO's original bus format and all the bus addresses are controlled by SANYO.

■ Any and all SANYO products described or contained herein do not have specifications that can handle applications that require extremely high levels of reliability, such as life-support systems, aircraft's control systems, or other applications whose failure can be reasonably expected to result in serious physical and/or material damage. Consult with your SANYO representative nearest you before using any SANYO products described or contained herein in such applications.

■ SANYO assumes no responsibility for equipment failures that result from using products at values that exceed, even momentarily, rated values (such as maximum ratings, operating condition ranges, or other parameters) listed in products specifications of any and all SANYO products described or contained herein.

SANYO Electric Co.,Ltd. Semiconductor Business Headquarters

TOKYO OFFICE Tokyo Bldg., 1-10, 1 Chome, Ueno, Taito-ku, TOKYO, 110-8534 JAPAN

LC72135M

Pin Assignment

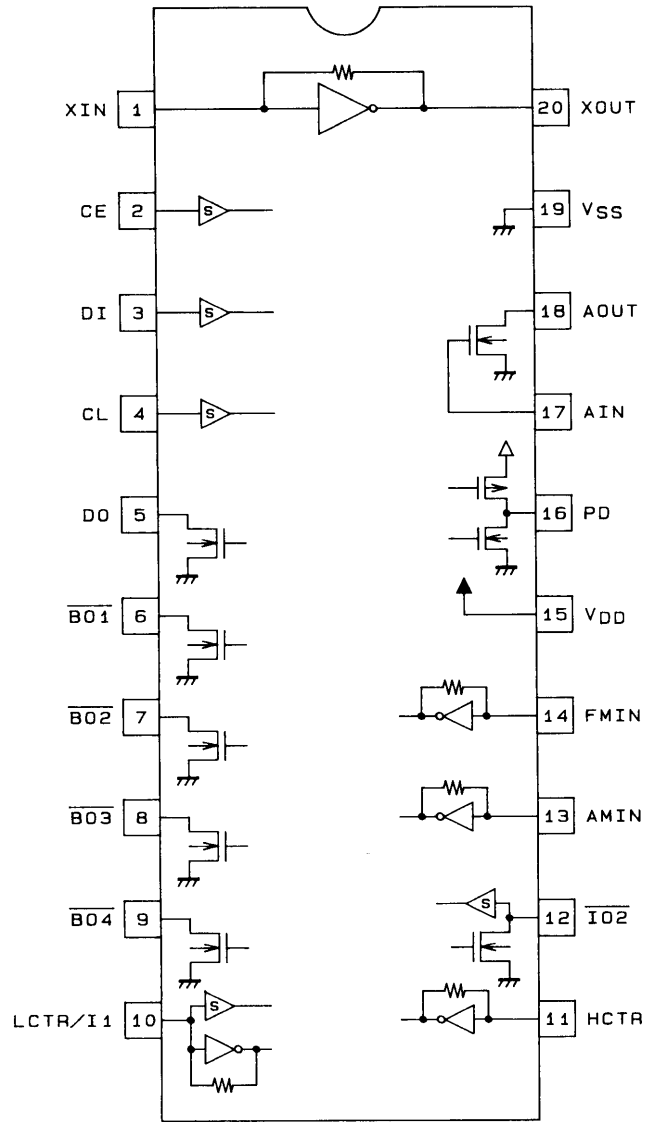

Top view

A04186

LC72135M

Block Diagram

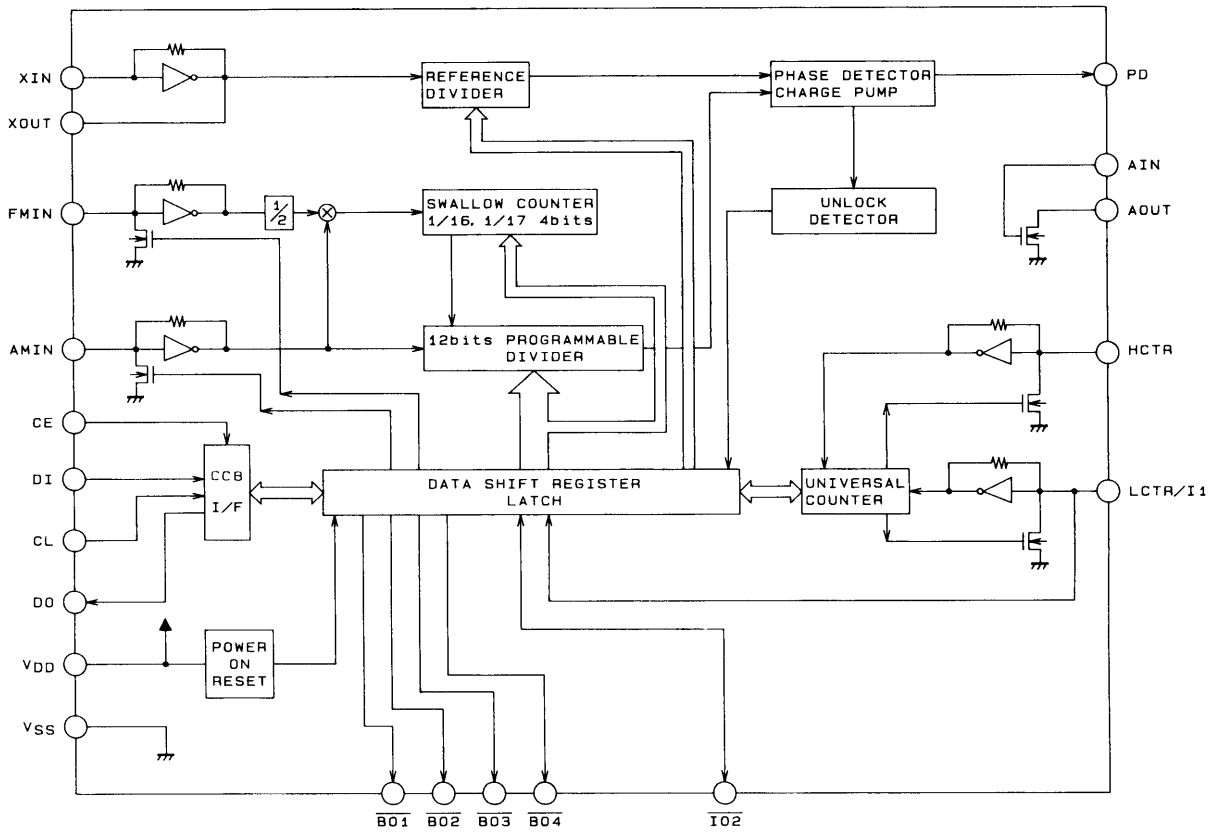

A04187

LC72135M

Specifications

Absolute Maximum Ratings at $T_a = 25^\circ\text{C}$, $V_{SS} = 0\text{ V}$

Parameter	Symbol	Pins	Ratings	Unit
Maximum supply voltage	$V_{DD\text{ max}}$	V_{DD}	-0.3 to +7.0	V
Maximum input voltage	$V_{IN1\text{ max}}$	CE, CL, DI, AIN	-0.3 to +7.0	V
	$V_{IN2\text{ max}}$	XIN, FMIN, AMIN, HCTR, LCTR/I1	-0.3 to $V_{DD} + 0.3$	V
	$V_{IN3\text{ max}}$	$\overline{IO2}$	-0.3 to +15	V
Maximum output voltage	$V_{O1\text{ max}}$	DO	-0.3 to +7.0	V
	$V_{O2\text{ max}}$	XOUT, PD	-0.3 to $V_{DD} + 0.3$	V
	$V_{O3\text{ max}}$	$\overline{BO1}$ to $\overline{BO4}$, $\overline{IO2}$, AOUT	-0.3 to +15	V
Maximum output current	$I_{O1\text{ max}}$	$\overline{BO1}$	0 to 3.0	mA
	$I_{O2\text{ max}}$	AOUT, DO	0 to 6.0	mA
	$I_{O3\text{ max}}$	$\overline{BO2}$ to $\overline{BO4}$, $\overline{IO2}$	0 to 10.0	mA
Allowable power dissipation	$Pd\text{ max}$	$T_a \leq 85^\circ\text{C}$	180	mW
Operating temperature	T_{opr}		-40 to +85	$^\circ\text{C}$
Storage temperature	T_{stg}		-55 to +125	$^\circ\text{C}$

Allowable Operating Ranges at $T_a = -40$ to $+85^\circ\text{C}$, $V_{SS} = 0\text{ V}$

Parameter	Symbol	Pins	Conditions	min	typ	max	Unit
Supply voltage	V_{DD}	V_{DD}		4.5		5.5	V
Input high-level voltage	V_{IH1}	CE, CL, DI		$0.7 V_{DD}$		6.5	V
	V_{IH2}	LCTR/I1		$0.7 V_{DD}$		V_{DD}	V
	V_{IH3}	$\overline{IO2}$		$0.7 V_{DD}$		13	V
Input low-level voltage	V_{IL}	CE, CL, DI, $\overline{IO2}$, LCTR/I1		0		$0.3 V_{DD}$	V
Output voltage	V_{O1}	DO		0		+6.5	V
	V_{O2}	$\overline{BO1}$ to $\overline{BO4}$, $\overline{IO2}$, AOUT		0		+13	V
Input frequency	f_{IN1}	XIN	V_{IN1}	1		8	MHz
	f_{IN2}	FMIN	V_{IN2}	10		160	MHz
	f_{IN3}	AMIN	V_{IN3} , SNS = 1	2		40	MHz
	f_{IN4}	AMIN	V_{IN4} , SNS = 0	0.5		10	MHz
	f_{IN5}	HCTR	V_{IN5}	0.4		12	MHz
	f_{IN6}	LCTR/I1	V_{IN6}	100		500	kHz
Input amplitude	V_{IN1}	XIN	f_{IN1}	400		1500	mVrms
	V_{IN2-1}	FMIN	$f = 10$ to 130 MHz	40		1500	mVrms
	V_{IN2-2}	FMIN	$f = 130$ to 160 MHz	70		1500	mVrms
	V_{IN3}	AMIN	f_{IN3} , SNS = 1	40		1500	mVrms
	V_{IN4}	AMIN	f_{IN4} , SNS = 0	40		1500	mVrms
	V_{IN5-1}	HCTR	f_{IN5} , IFS = 1	40		1500	mVrms
	V_{IN5-2}	HCTR	f_{IN5} , IFS = 0	70		1500	mVrms
	V_{IN6-1}	LCTR/I1	f_{IN6} , IFS = 1	40		1500	mVrms
V_{IN6-2}	LCTR/I1	f_{IN6} , IFS = 0	70		1500	mVrms	
Supported crystals	Xtal	XIN, XOUT	*	4.0		8.0	MHz

Note: * Recommended crystal oscillator CI values:

$CI \leq 120\Omega$ (For a 4.5 MHz crystal)

$CI \leq 70\Omega$ (For a 7.2 MHz crystal)

<Sample Oscillator Circuit>

Crystal oscillator: HC-49/U (manufactured by Kinseki, Ltd.), $CL = 12\text{ pF}$

$C1 = C2 = 15\text{ pF}$

The circuit constants for the crystal oscillator circuit depend on the crystal used, the printed circuit board pattern, and other items. Therefore we recommend consulting with the manufacturer of the crystal about evaluation and reliability.

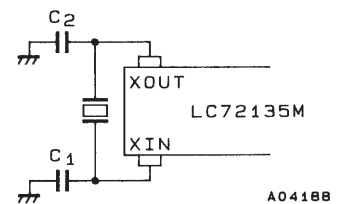

LC72135M

Electrical Characteristics for the Allowable Operating Ranges at $T_a = -40$ to $+85^\circ\text{C}$, $V_{SS} = 0\text{ V}$

Parameter	Symbol	Pins	Conditions	min	typ	max	Unit
Built-in feedback resistance	Rf1	XIN			1.0		M Ω
	Rf2	FMIN			500		k Ω
	Rf3	AMIN			500		k Ω
	Rf4	HCTR			250		k Ω
	Rf5	LCTR/I1			250		k Ω
Built-in pull-down resistor	Rpd1	FMIN			200		k Ω
	Rpd2	AMIN			200		k Ω
Hysteresis	V_{HIS}	CE, CL, DI, $\overline{IO2}$, LCTR/I1			$0.1 V_{DD}$		V
Output high-level voltage	V_{OH1}	PD	$I_O = -1\text{ mA}$	$V_{DD} - 1.0$			V
Output low-level voltage	V_{OL1}	PD	$I_O = 1\text{ mA}$			1.0	V
	V_{OL2}	$\overline{BO1}$	$I_O = 0.5\text{ mA}$			0.5	V
			$I_O = 1\text{ mA}$			1.0	V
	V_{OL3}	DO	$I_O = 1\text{ mA}$			0.2	V
			$I_O = 5\text{ mA}$			1.0	V
	V_{OL4}	$\overline{BO2}$ to $\overline{BO4}$, $\overline{IO2}$	$I_O = 1\text{ mA}$			0.2	V
			$I_O = 5\text{ mA}$			1.0	V
$I_O = 8\text{ mA}$					1.6	V	
V_{OL5}	AOUT	$I_O = 1\text{ mA}$, $A_{IN} = 1.3\text{ V}$			0.5	V	
Input high-level current	I_{IH1}	CE, CL, DI	$V_I = 6.5\text{ V}$			5.0	V
	I_{IH2}	LCTR/I1	$V_I = V_{DD}$, $L/I1 = 0$			5.0	μA
	I_{IH3}	$\overline{IO2}$	$V_I = 13\text{ V}$			5.0	μA
	I_{IH4}	XIN	$V_I = V_{DD}$	2.0		11	μA
	I_{IH5}	FMIN, AMIN	$V_I = V_{DD}$	4.0		22	μA
	I_{IH6}	HCTR, LCTR/I1	$V_I = V_{DD}$, $L/I1 = 1$	8.0		44	μA
	I_{IH7}	AIN	$V_I = 6.5\text{ V}$			200	nA
Input low-level current	I_{IL1}	CE, CL, DI	$V_I = 0\text{ V}$			5.0	μA
	I_{IL2}	LCTR/I1	$V_I = 0\text{ V}$, $L/I1 = 0$			5.0	μA
	I_{IL3}	$\overline{IO2}$	$V_I = 0\text{ V}$			5.0	μA
	I_{IL4}	XIN	$V_I = 0\text{ V}$	2.0		11	μA
	I_{IL5}	FMIN, AMIN	$V_I = 0\text{ V}$	4.0		22	μA
	I_{IL6}	HCTR, LCTR/I1	$V_I = 0\text{ V}$, $L/I1 = 1$	8.0		44	μA
	I_{IL7}	AIN	$V_I = 0\text{ V}$			200	nA
Output off leakage current	I_{OFF1}	$\overline{BO1}$ to $\overline{BO4}$, AOUT, $\overline{IO2}$	$V_O = 13\text{ V}$			5.0	μA
	I_{OFF2}	DO	$V_O = 6.5\text{ V}$			5.0	μA
High-level three-state off leakage current	I_{OFFH}	PD	$V_O = V_{DD}$		0.01	200	nA
Low-level three-state off leakage current	I_{OFFL}	PD	$V_O = 0\text{ V}$		0.01	200	nA
Input capacitance	C_{IN}	FMIN			6		pF
Current drain	I_{DD1}	V_{DD}	Xtal = 7.2 MHz, $f_{IN2} = 130\text{ MHz}$, $V_{IN2} = 40\text{ mVrms}$		5	10	mA
	I_{DD2}	V_{DD}	PLL block stopped (PLL INHIBIT), Xtal oscillator operating (Xtal = 7.2 MHz)		0.5		mA
	I_{DD3}	V_{DD}	PLL block stopped Xtal oscillator stopped			10	μA

LC72135M

Pin Functions

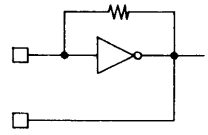
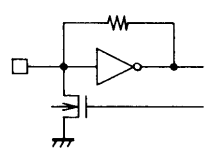
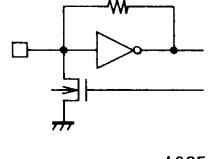
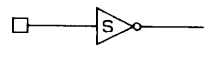
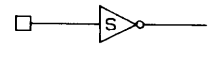
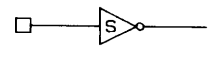
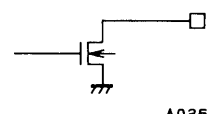
Symbol	Pin No.	Type	Functions	Circuit configuration
XIN XOUT	1 20	Xtal OSC	<ul style="list-style-type: none"> Crystal resonator connection (4.5/7.2 MHz) 	 <p style="text-align: right;">A02598</p>
FMIN	14	Local oscillator signal input	<ul style="list-style-type: none"> FMIN is selected when the serial data input DVS bit is set to 1. The input frequency range is from 10 to 160 MHz. The input signal passes through the internal divide-by-two prescaler and is input to the swallow counter. The divisor can be in the range 272 to 65535. However, since the signal has passed through the divide-by-two prescaler, the actual divisor is twice the set value. 	 <p style="text-align: right;">A02599</p>
AMIN	13	Local oscillator signal input	<ul style="list-style-type: none"> AMIN is selected when the serial data input DVS bit is set to 0. When the serial data input SNS bit is set to 1: <ul style="list-style-type: none"> The input frequency range is 2 to 40 MHz. The signal is directly input to the swallow counter. The divisor can be in the range 272 to 65535, and the divisor used will be the value set. When the serial data input SNS bit is set to 0: <ul style="list-style-type: none"> The input frequency range is 0.5 to 10 MHz. The signal is directly input to a 12-bit programmable divider. The divisor can be in the range 4 to 4095, and the divisor used will be the value set. 	 <p style="text-align: right;">A02599</p>
CE	2	Chip enable	Set this pin high when inputting (DI) or outputting (DO) serial data.	 <p style="text-align: right;">A02600</p>
CL	4	Clock	<ul style="list-style-type: none"> Used as the synchronization clock when inputting (DI) or outputting (DO) serial data. 	 <p style="text-align: right;">A02600</p>
DI	3	Data input	<ul style="list-style-type: none"> Inputs serial data transferred from the controller to the LC72135M. 	 <p style="text-align: right;">A02600</p>
DO	5	Data output	<ul style="list-style-type: none"> Outputs serial data transferred from the LC72135M to the controller. The content of the output data is determined by the serial data DOC0 to DOC2. 	 <p style="text-align: right;">A02601</p>
V _{DD}	15	Power supply	<ul style="list-style-type: none"> The LC72135M power supply pin (V_{DD} = 4.5 to 5.5 V) The power on reset circuit operates when power is first applied. 	

Continued on next page.

LC72135M

Continued from preceding page.

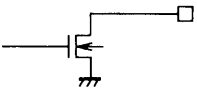
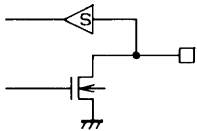
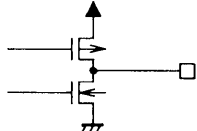
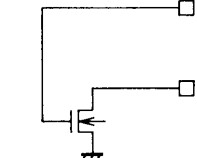
Symbol	Pin No.	Type	Functions	Circuit configuration
V _{SS}	19	Ground	<ul style="list-style-type: none"> The LC72135M ground 	—
$\overline{\text{BO1}}$ $\overline{\text{BO2}}$ $\overline{\text{BO3}}$ $\overline{\text{BO4}}$	6 7 8 9	Output port	<ul style="list-style-type: none"> Dedicated output pins The output states are determined by BO1 to BO4 bits in the serial data. Data: 0 = open, 1 = low All output ports are set to the open state following a power-on reset. A time base signal (8 Hz) can be output from the $\overline{\text{BO1}}$ pin. (When the serial data TBC bit is set to 1.) Care is required when using the $\overline{\text{BO1}}$ pin, since it has a higher on impedance than the other output ports (pins BO2 to BO4). 	 A02601
$\overline{\text{IO2}}$	12	I/O port	<ul style="list-style-type: none"> I/O dual-use pins The direction (input or output) is determined by bit IOC2 in the serial data. Data: 0 = input port, 1 = output port When specified for use as input ports: The state of the input pin is transmitted to the controller over the DO pin. Input state: low = 0 data value high = 1 data value When specified for use as output ports: The output states are determined by the IO2 bit in the serial data. Data: 0 = open, 1 = low The pin function as input pin following a power-on reset. 	 A02602
PD	16	Charge pump output	<ul style="list-style-type: none"> PLL charge pump output When the frequency generated by dividing the local oscillator frequency by N is higher than the reference frequency, a high level is output from the PD pin. Similarly, when that frequency is lower, a low level is output. The PD pin goes to the high-impedance state when the frequencies match. 	 A02603
AIN AOUT	17 18	LPF amplifier transistor	<ul style="list-style-type: none"> The n-channel MOS transistor used for the PLL active low-pass filter. 	 A02604

Continued on next page.

LC72135M

Continued from preceding page.

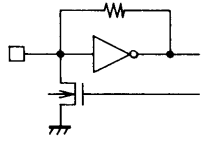
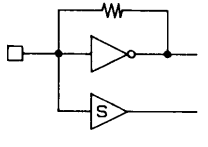
Symbol	Pin No.	Type	Functions	Circuit configuration
HCTR	11	IF counter	<ul style="list-style-type: none"> HCTR is selected when the LCTS bit in the serial data is set to 0. Accepts an input in the frequency range 0.4 to 12 MHz. The input signal is directly transmitted to the IF counter. The result is output starting the MSB of the IF counter using the DO pin. Four measurement periods are supported: 4, 8, 32, and 64 ms. 	 <p style="text-align: right;">A02599</p>
LCTR/I1	10	IF counter Input port	<ul style="list-style-type: none"> LCTR is selected when the LCTS bit in the serial data is set to 1. (Set the L/I1 bit in the serial data to 1 when using the IF counter.) The input frequency range is 100 to 500 kHz. The signal is directly transmitted to the IF counter. The result, starting with the MSB of the IF counter, is output serially through the DO pin. There are four measurement times: 4, 8, 32, and 64 ms. If the L/I1 bit in the serial data is set to 0, the LCTR/I1 pin functions as an input port and the state of that input pin is transmitted to the controller from the DO pin. When the input state is low, the data will be 0, and when the state is high, the data will be 1. 	 <p style="text-align: right;">A04189</p>

LC72135M

Serial Data I/O Methods

The LC72135M inputs and outputs data using the Sanyo CCB (computer control bus) audio LSI serial bus format. This LSI adopts an 8-bit address format CCB.

	I/O mode	Address								Function
		B0	B1	B2	B3	A0	A1	A2	A3	
1	IN1 (82)	0	0	0	1	0	1	0	0	<ul style="list-style-type: none"> Control data input mode (serial data input) 24 data bits are input. See the "DI Control Data (serial data input) Structure" item for details on the meaning of the input data.
2	IN2 (92)	1	0	0	1	0	1	0	0	<ul style="list-style-type: none"> Control data input mode (serial data input) 24 data bits are input. See the "DI Control Data (serial data input) Structure" item for details on the meaning of the input data.
3	OUT (A2)	0	1	0	1	0	1	0	0	<ul style="list-style-type: none"> Data output mode (serial data output) The number of bits output is equal to the number of clock cycles. See the "DO Output Data (Serial Data Output) Structure" item for details on the meaning of the output data.

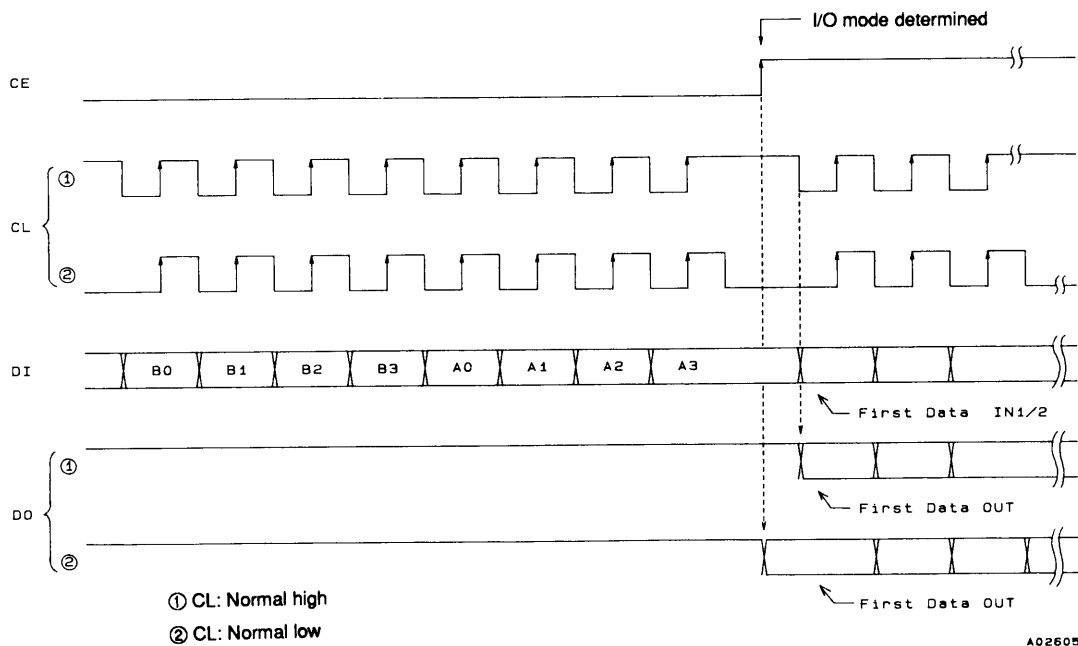

1. DI Control Data (Serial Data Input) Structure

- IN1 Mode

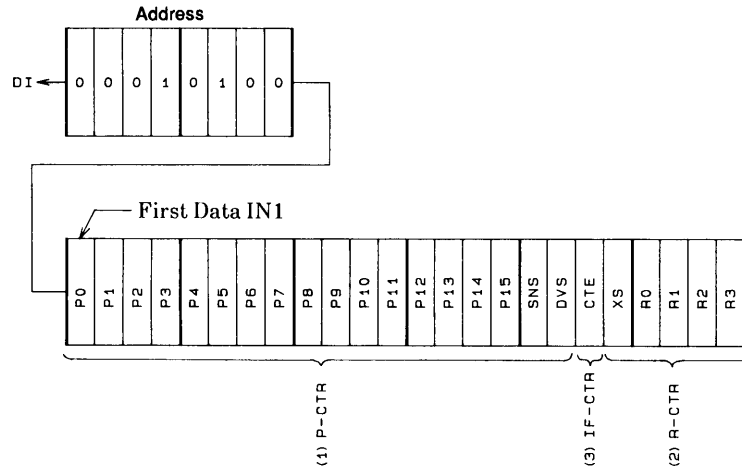

A02606

- IN2 Mode

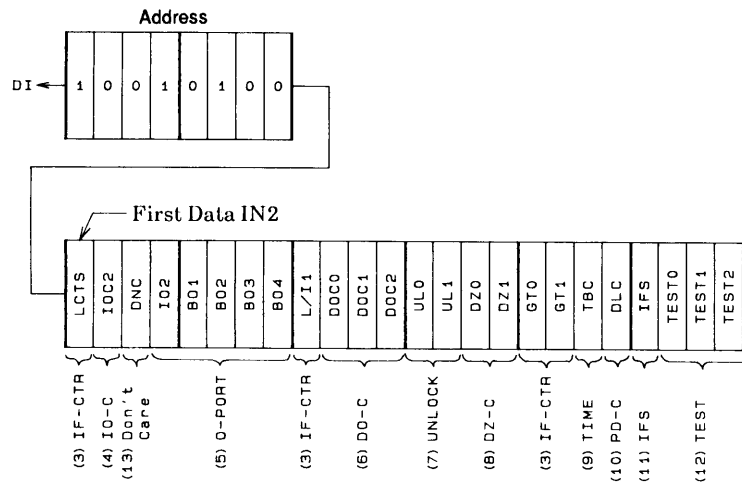

A04190

LC72135M

2. DI Control Data Functions

No.	Control block/data	Functions	Related data																																																																																					
(1)	Programmable divider data P0 to P15 DVS, SNS	<ul style="list-style-type: none"> Data that sets the programmable divider. A binary value in which P15 is the MSB. The LSB changes depending on DVS and SNS. (*: don't care) <table border="1" style="width: 100%; border-collapse: collapse; margin-bottom: 5px;"> <thead> <tr> <th>DVS</th> <th>SNS</th> <th>LSB</th> <th>Divisor setting (N)</th> <th>Actual divisor</th> </tr> </thead> <tbody> <tr> <td style="text-align: center;">1</td> <td style="text-align: center;">*</td> <td style="text-align: center;">P0</td> <td style="text-align: center;">272 to 65535</td> <td style="text-align: center;">Twice the value of the setting</td> </tr> <tr> <td style="text-align: center;">0</td> <td style="text-align: center;">1</td> <td style="text-align: center;">P0</td> <td style="text-align: center;">272 to 65535</td> <td style="text-align: center;">The value of the setting</td> </tr> <tr> <td style="text-align: center;">0</td> <td style="text-align: center;">0</td> <td style="text-align: center;">P4</td> <td style="text-align: center;">4 to 4095</td> <td style="text-align: center;">The value of the setting</td> </tr> </tbody> </table> <p style="font-size: small;">Note: P0 to P3 are ignored when P4 is the LSB.</p> <ul style="list-style-type: none"> Selects the signal input pin (AMIN or FMIN) for the programmable divider, switches the input frequency range. (*: don't care) <table border="1" style="width: 100%; border-collapse: collapse; margin-bottom: 5px;"> <thead> <tr> <th>DVS</th> <th>SNS</th> <th>Input pin</th> <th>Input frequency range</th> </tr> </thead> <tbody> <tr> <td style="text-align: center;">1</td> <td style="text-align: center;">*</td> <td style="text-align: center;">FMIN</td> <td style="text-align: center;">10 to 160 MHz</td> </tr> <tr> <td style="text-align: center;">0</td> <td style="text-align: center;">1</td> <td style="text-align: center;">AMIN</td> <td style="text-align: center;">2 to 40 MHz</td> </tr> <tr> <td style="text-align: center;">0</td> <td style="text-align: center;">0</td> <td style="text-align: center;">AMIN</td> <td style="text-align: center;">0.5 to 10 MHz</td> </tr> </tbody> </table> <p style="font-size: small;">Note: See the "Programmable Divider" item for more information.</p>	DVS	SNS	LSB	Divisor setting (N)	Actual divisor	1	*	P0	272 to 65535	Twice the value of the setting	0	1	P0	272 to 65535	The value of the setting	0	0	P4	4 to 4095	The value of the setting	DVS	SNS	Input pin	Input frequency range	1	*	FMIN	10 to 160 MHz	0	1	AMIN	2 to 40 MHz	0	0	AMIN	0.5 to 10 MHz																																																		
DVS	SNS	LSB	Divisor setting (N)	Actual divisor																																																																																				
1	*	P0	272 to 65535	Twice the value of the setting																																																																																				
0	1	P0	272 to 65535	The value of the setting																																																																																				
0	0	P4	4 to 4095	The value of the setting																																																																																				
DVS	SNS	Input pin	Input frequency range																																																																																					
1	*	FMIN	10 to 160 MHz																																																																																					
0	1	AMIN	2 to 40 MHz																																																																																					
0	0	AMIN	0.5 to 10 MHz																																																																																					
(2)	Reference divider data R0 to R3 XS	<ul style="list-style-type: none"> Reference frequency (fref) selection data. <table border="1" style="width: 100%; border-collapse: collapse; margin-bottom: 5px;"> <thead> <tr> <th>R3</th> <th>R2</th> <th>R1</th> <th>R0</th> <th>Reference frequency (kHz)</th> </tr> </thead> <tbody> <tr><td style="text-align: center;">0</td><td style="text-align: center;">0</td><td style="text-align: center;">0</td><td style="text-align: center;">0</td><td style="text-align: center;">100</td></tr> <tr><td style="text-align: center;">0</td><td style="text-align: center;">0</td><td style="text-align: center;">0</td><td style="text-align: center;">1</td><td style="text-align: center;">50</td></tr> <tr><td style="text-align: center;">0</td><td style="text-align: center;">0</td><td style="text-align: center;">1</td><td style="text-align: center;">0</td><td style="text-align: center;">25</td></tr> <tr><td style="text-align: center;">0</td><td style="text-align: center;">0</td><td style="text-align: center;">1</td><td style="text-align: center;">1</td><td style="text-align: center;">25</td></tr> <tr><td style="text-align: center;">0</td><td style="text-align: center;">1</td><td style="text-align: center;">0</td><td style="text-align: center;">0</td><td style="text-align: center;">12.5</td></tr> <tr><td style="text-align: center;">0</td><td style="text-align: center;">1</td><td style="text-align: center;">0</td><td style="text-align: center;">1</td><td style="text-align: center;">6.25</td></tr> <tr><td style="text-align: center;">0</td><td style="text-align: center;">1</td><td style="text-align: center;">1</td><td style="text-align: center;">0</td><td style="text-align: center;">3.125</td></tr> <tr><td style="text-align: center;">0</td><td style="text-align: center;">1</td><td style="text-align: center;">1</td><td style="text-align: center;">1</td><td style="text-align: center;">3.125</td></tr> <tr><td style="text-align: center;">1</td><td style="text-align: center;">0</td><td style="text-align: center;">0</td><td style="text-align: center;">0</td><td style="text-align: center;">10</td></tr> <tr><td style="text-align: center;">1</td><td style="text-align: center;">0</td><td style="text-align: center;">0</td><td style="text-align: center;">1</td><td style="text-align: center;">9</td></tr> <tr><td style="text-align: center;">1</td><td style="text-align: center;">0</td><td style="text-align: center;">1</td><td style="text-align: center;">0</td><td style="text-align: center;">5</td></tr> <tr><td style="text-align: center;">1</td><td style="text-align: center;">0</td><td style="text-align: center;">1</td><td style="text-align: center;">1</td><td style="text-align: center;">1</td></tr> <tr><td style="text-align: center;">1</td><td style="text-align: center;">1</td><td style="text-align: center;">0</td><td style="text-align: center;">0</td><td style="text-align: center;">3</td></tr> <tr><td style="text-align: center;">1</td><td style="text-align: center;">1</td><td style="text-align: center;">0</td><td style="text-align: center;">1</td><td style="text-align: center;">15</td></tr> <tr><td style="text-align: center;">1</td><td style="text-align: center;">1</td><td style="text-align: center;">1</td><td style="text-align: center;">0</td><td style="text-align: center;">PLL INHIBIT + Xtal OSC STOP</td></tr> <tr><td style="text-align: center;">1</td><td style="text-align: center;">1</td><td style="text-align: center;">1</td><td style="text-align: center;">1</td><td style="text-align: center;">PLL INHIBIT</td></tr> </tbody> </table> <p style="font-size: small;">Note: PLL INHIBIT The programmable divider block and the IF counter block are stopped, the FMIN, AMIN, HCTR and LCTR pins are set to the pull-down state (ground), and the charge pump goes to the high impedance state.</p> <ul style="list-style-type: none"> Crystal resonator selection XS = 0: 4.5 MHz XS = 1: 7.2 MHz The 7.2 MHz frequency is selected after the power-on reset. 	R3	R2	R1	R0	Reference frequency (kHz)	0	0	0	0	100	0	0	0	1	50	0	0	1	0	25	0	0	1	1	25	0	1	0	0	12.5	0	1	0	1	6.25	0	1	1	0	3.125	0	1	1	1	3.125	1	0	0	0	10	1	0	0	1	9	1	0	1	0	5	1	0	1	1	1	1	1	0	0	3	1	1	0	1	15	1	1	1	0	PLL INHIBIT + Xtal OSC STOP	1	1	1	1	PLL INHIBIT	
R3	R2	R1	R0	Reference frequency (kHz)																																																																																				
0	0	0	0	100																																																																																				
0	0	0	1	50																																																																																				
0	0	1	0	25																																																																																				
0	0	1	1	25																																																																																				
0	1	0	0	12.5																																																																																				
0	1	0	1	6.25																																																																																				
0	1	1	0	3.125																																																																																				
0	1	1	1	3.125																																																																																				
1	0	0	0	10																																																																																				
1	0	0	1	9																																																																																				
1	0	1	0	5																																																																																				
1	0	1	1	1																																																																																				
1	1	0	0	3																																																																																				
1	1	0	1	15																																																																																				
1	1	1	0	PLL INHIBIT + Xtal OSC STOP																																																																																				
1	1	1	1	PLL INHIBIT																																																																																				
(3)	IF counter control data CTE GT0, GT1 IF counter selection data LCTS L/I1	<ul style="list-style-type: none"> IF counter measurement start data CTE = 1: Counter start CTE = 0: Counter reset Determines the IF counter measurement period. <table border="1" style="width: 100%; border-collapse: collapse; margin-bottom: 5px;"> <thead> <tr> <th>GT1</th> <th>GT0</th> <th>Measurement time (ms)</th> <th>Wait time (ms)</th> </tr> </thead> <tbody> <tr> <td style="text-align: center;">0</td> <td style="text-align: center;">0</td> <td style="text-align: center;">4</td> <td style="text-align: center;">3 to 4</td> </tr> <tr> <td style="text-align: center;">0</td> <td style="text-align: center;">1</td> <td style="text-align: center;">8</td> <td style="text-align: center;">3 to 4</td> </tr> <tr> <td style="text-align: center;">1</td> <td style="text-align: center;">0</td> <td style="text-align: center;">32</td> <td style="text-align: center;">7 to 8</td> </tr> <tr> <td style="text-align: center;">1</td> <td style="text-align: center;">1</td> <td style="text-align: center;">64</td> <td style="text-align: center;">7 to 8</td> </tr> </tbody> </table> <p style="font-size: small;">Note: See the "IF Counter" item for more information.</p> <ul style="list-style-type: none"> Data that specifies the IF counter input pin (and mode). LCTS = 0: HCTR, LCTS = 1: LCTR L/I1 = 0: I1 (Input port), L/I1 = 1: LCTR (AM IF counter) <table border="1" style="width: 100%; border-collapse: collapse; margin-bottom: 5px;"> <thead> <tr> <th>LCTS</th> <th>L/I1</th> <th>LCTR/I1 pin</th> <th>HCTR pin</th> </tr> </thead> <tbody> <tr> <td style="text-align: center;">0</td> <td style="text-align: center;">0</td> <td style="text-align: center;">I1 (input port)</td> <td style="text-align: center;">HCTR</td> </tr> <tr> <td style="text-align: center;">0</td> <td style="text-align: center;">1</td> <td style="text-align: center;">Off (pulled down)</td> <td style="text-align: center;">(FM/AM IF counter)</td> </tr> <tr> <td style="text-align: center;">1</td> <td style="text-align: center;">0</td> <td style="text-align: center;">I1 (input port)</td> <td style="text-align: center;">Off</td> </tr> <tr> <td style="text-align: center;">1</td> <td style="text-align: center;">1</td> <td style="text-align: center;">LCTR (AM IF counter)</td> <td style="text-align: center;">(pulled down)</td> </tr> </tbody> </table>	GT1	GT0	Measurement time (ms)	Wait time (ms)	0	0	4	3 to 4	0	1	8	3 to 4	1	0	32	7 to 8	1	1	64	7 to 8	LCTS	L/I1	LCTR/I1 pin	HCTR pin	0	0	I1 (input port)	HCTR	0	1	Off (pulled down)	(FM/AM IF counter)	1	0	I1 (input port)	Off	1	1	LCTR (AM IF counter)	(pulled down)	IFS																																													
GT1	GT0	Measurement time (ms)	Wait time (ms)																																																																																					
0	0	4	3 to 4																																																																																					
0	1	8	3 to 4																																																																																					
1	0	32	7 to 8																																																																																					
1	1	64	7 to 8																																																																																					
LCTS	L/I1	LCTR/I1 pin	HCTR pin																																																																																					
0	0	I1 (input port)	HCTR																																																																																					
0	1	Off (pulled down)	(FM/AM IF counter)																																																																																					
1	0	I1 (input port)	Off																																																																																					
1	1	LCTR (AM IF counter)	(pulled down)																																																																																					

Continued on next page.

LC72135M

Continued from preceding page.

No.	Control block/data	Functions	Related data																																				
(4)	I/O port specification data IOC2	<ul style="list-style-type: none"> Specifies the I/O direction for the bidirectional pin $\overline{IO2}$. Data: 0 = input mode, 1 = output mode 																																					
(5)	Output port data BO1 to BO4, IO2	<ul style="list-style-type: none"> Data that determines the output from the $\overline{BO1}$ to $\overline{BO4}$, and IO2 output ports Data: 0 = open, 1 = low The data = 0 (open) state is selected after the power-on reset. 	IOC2																																				
(6)	DO pin control data DOC0, DOC1, DOC2	<ul style="list-style-type: none"> Data that determines the DO pin output <table border="1" style="width: 100%; border-collapse: collapse; margin-bottom: 10px;"> <thead> <tr> <th>DOC2</th> <th>DOC1</th> <th>DOC0</th> <th>DO pin state</th> </tr> </thead> <tbody> <tr> <td>0</td> <td>0</td> <td>0</td> <td>Open</td> </tr> <tr> <td>0</td> <td>0</td> <td>1</td> <td>Low when the unlock state is detected</td> </tr> <tr> <td>0</td> <td>1</td> <td>0</td> <td>end-UC*1</td> </tr> <tr> <td>0</td> <td>1</td> <td>1</td> <td>Open</td> </tr> <tr> <td>1</td> <td>0</td> <td>0</td> <td>Open</td> </tr> <tr> <td>1</td> <td>0</td> <td>1</td> <td>The LCTR/I1 pin state*2</td> </tr> <tr> <td>1</td> <td>1</td> <td>0</td> <td>The $\overline{IO2}$ pin state*3</td> </tr> <tr> <td>1</td> <td>1</td> <td>1</td> <td>Open</td> </tr> </tbody> </table> <p>The open state is selected after the power-on reset.</p> <p>Note: 1. end-UC: Check for IF counter measurement completion</p> <div style="text-align: center;"> </div> <ol style="list-style-type: none"> ①. When end-UC is set and the IF counter is started (i.e., when CTE is changed from zero to one), the DO pin automatically goes to the open state. ② When the IF counter measurement completes, the DO pin goes low to indicate the measurement completion state. ③ Depending on serial data I/O (CE: high) the DO pin goes to the open state. <ol style="list-style-type: none"> 2. Goes to the open state if the LCTR/I1 pin is set to the AM-IF counter function (L/I1 = 1). 3. Goes to the open state if the I/O pin is specified to be an output port. <p>Caution: The state of the DO pin during a data input period (an IN1 or IN2 mode period with CE high) will be open, regardless of the state of the DO control data (DOC0 to DOC2). Also, the DO pin during a data output period (an OUT mode period with CE high) will output the contents of the internal DO serial data in synchronization with the CL pin signal, regardless of the state of the DO control data (DOC0 to DOC2).</p>	DOC2	DOC1	DOC0	DO pin state	0	0	0	Open	0	0	1	Low when the unlock state is detected	0	1	0	end-UC*1	0	1	1	Open	1	0	0	Open	1	0	1	The LCTR/I1 pin state*2	1	1	0	The $\overline{IO2}$ pin state*3	1	1	1	Open	UL0, UL1, CTE, IOC2
DOC2	DOC1	DOC0	DO pin state																																				
0	0	0	Open																																				
0	0	1	Low when the unlock state is detected																																				
0	1	0	end-UC*1																																				
0	1	1	Open																																				
1	0	0	Open																																				
1	0	1	The LCTR/I1 pin state*2																																				
1	1	0	The $\overline{IO2}$ pin state*3																																				
1	1	1	Open																																				
(7)	Unlock detection data UL0, UL1	<ul style="list-style-type: none"> Selects the phase error (ϕE) detection width for checking PLL lock. A phase error in excess of the specified detection width is seen as an unlocked state. <table border="1" style="width: 100%; border-collapse: collapse; margin-bottom: 10px;"> <thead> <tr> <th>UL1</th> <th>UL0</th> <th>ϕE detection width</th> <th>Detector output</th> </tr> </thead> <tbody> <tr> <td>0</td> <td>0</td> <td>Stopped</td> <td>Open</td> </tr> <tr> <td>0</td> <td>1</td> <td>0</td> <td>ϕE is output directly</td> </tr> <tr> <td>1</td> <td>0</td> <td>$\pm 0.55 \mu s$</td> <td>ϕE is extended by 1 to 2 ms</td> </tr> <tr> <td>1</td> <td>1</td> <td>$\pm 1.11 \mu s$</td> <td>ϕE is extended by 1 to 2 ms</td> </tr> </tbody> </table> <p>Note: In the unlocked state the DO pin goes low and the UL bit in the serial data becomes zero.</p>	UL1	UL0	ϕE detection width	Detector output	0	0	Stopped	Open	0	1	0	ϕE is output directly	1	0	$\pm 0.55 \mu s$	ϕE is extended by 1 to 2 ms	1	1	$\pm 1.11 \mu s$	ϕE is extended by 1 to 2 ms	DOC0, DOC1, DOC2																
UL1	UL0	ϕE detection width	Detector output																																				
0	0	Stopped	Open																																				
0	1	0	ϕE is output directly																																				
1	0	$\pm 0.55 \mu s$	ϕE is extended by 1 to 2 ms																																				
1	1	$\pm 1.11 \mu s$	ϕE is extended by 1 to 2 ms																																				
(8)	Phase comparator control data DZ0, DZ1	<ul style="list-style-type: none"> Controls the phase comparator dead zone. <table border="1" style="width: 100%; border-collapse: collapse; margin-bottom: 10px;"> <thead> <tr> <th>DZ1</th> <th>DZ0</th> <th>Dead zone mode</th> </tr> </thead> <tbody> <tr> <td>0</td> <td>0</td> <td>DZA</td> </tr> <tr> <td>0</td> <td>1</td> <td>DZB</td> </tr> <tr> <td>1</td> <td>0</td> <td>DZC</td> </tr> <tr> <td>1</td> <td>1</td> <td>DZD</td> </tr> </tbody> </table> <p>Dead zone widths: DZA < DZB < DZC < DZD</p>	DZ1	DZ0	Dead zone mode	0	0	DZA	0	1	DZB	1	0	DZC	1	1	DZD																						
DZ1	DZ0	Dead zone mode																																					
0	0	DZA																																					
0	1	DZB																																					
1	0	DZC																																					
1	1	DZD																																					
(9)	Clock time base TBC	Setting TBC to one causes an 8 Hz, 40% duty clock time base signal to be output from the BO1 pin. (BO1 data is invalid in this mode.)	BO1																																				
(10)	Charge pump control data DLC	<ul style="list-style-type: none"> Forcibly controls the charge pump output. <table border="1" style="width: 100%; border-collapse: collapse; margin-bottom: 10px;"> <thead> <tr> <th>DLC</th> <th>Charge pump output</th> </tr> </thead> <tbody> <tr> <td>0</td> <td>Normal operation</td> </tr> <tr> <td>1</td> <td>Forced low</td> </tr> </tbody> </table> <p>Note: If deadlock occurs due to the VCO control voltage (V_{tune}) going to zero and the VCO oscillator stopping, deadlock can be cleared by forcing the charge pump output to low and setting V_{tune} to V_{CC}. (This is the deadlock clearing circuit.)</p>	DLC	Charge pump output	0	Normal operation	1	Forced low																															
DLC	Charge pump output																																						
0	Normal operation																																						
1	Forced low																																						

Continued on next page.

LC72135M

Continued from preceding page.

No.	Control block/data	Functions	Related data
(11)	IF counter control data IFS	<ul style="list-style-type: none"> This data should be set to 1 during normal operation. Note that if this value is set to zero the system enters input sensitivity degradation mode, and the sensitivity is reduced to 10 to 30 mV rms. * See the "IF Counter Operation" item for details. 	
(12)	LSI test data TEST 0 to 2	<ul style="list-style-type: none"> LSI test data TEST0 TEST1 TEST2 } These values must all be set to 0. <p>These test data are set to 0 automatically after the power-on reset.</p>	
(13)	DNC	Don't care. This data must be set to 0.	

3. DO Output Data (Serial Data Output)

- OUT Mode

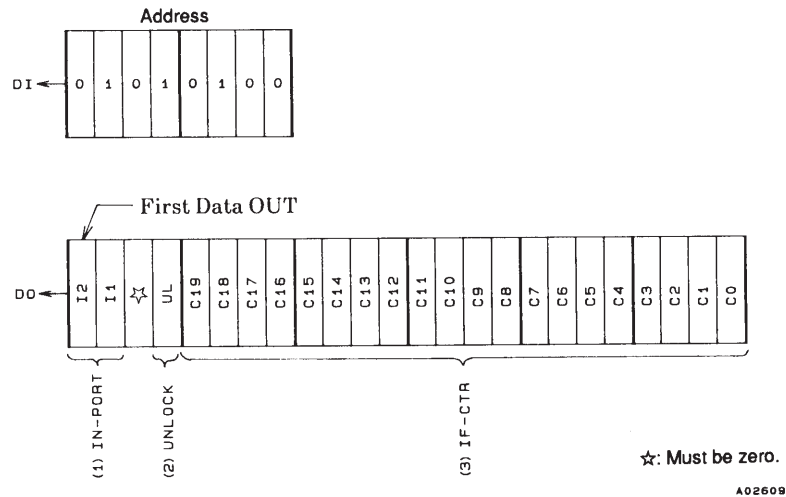

4. DO Output Data

No.	Control block/data	Functions	Related data
(1)	I/O port data I2, I1	<ul style="list-style-type: none"> Latched from the pin states of the LCTR/I1 input port (L/I1 bit is set to 0) and the $\overline{IO2}$ I/O port. These values follow the pin states regardless of the input or output setting. Data is latched when the data output mode is entered. I1 ← LCTR/I1 pin state } High: 1 I2 ← $\overline{IO2}$ pin state } Low: 0 	L/I1 IOC2
(2)	PLL unlock data UL	<ul style="list-style-type: none"> Latched from the state of the unlock detection circuit. UL ← 0: Unlocked UL ← 1: Locked or detection stopped mode 	UL0, UL1
(3)	IF counter binary data C19 to C0	<ul style="list-style-type: none"> Latched from the value of the IF counter (20-bit binary counter). C19 ← MSB of the binary counter C0 ← LSB of the binary counter 	CTE, GT0, GT1

LC72135M

5. Serial Data Input (IN1/IN2) $t_{SU}, t_{HD}, t_{EL}, t_{ES}, t_{EH} \geq 0.75 \mu s, t_{LC} \leq 0.75 \mu s$

① CL: Normal high

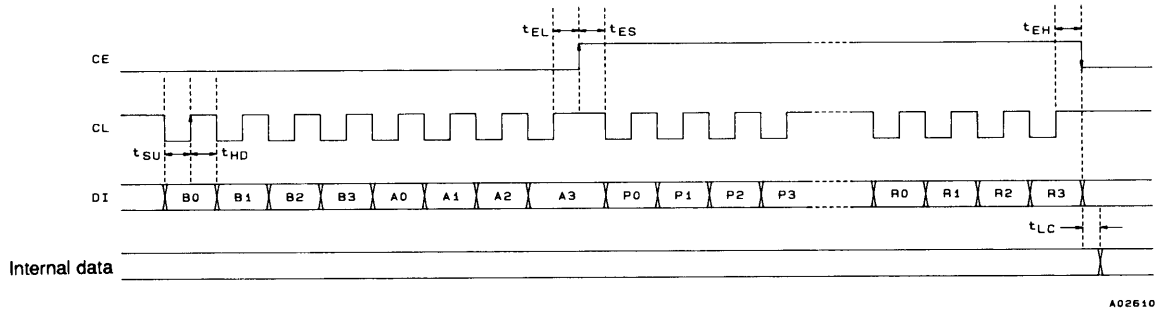

② CL: Normal low

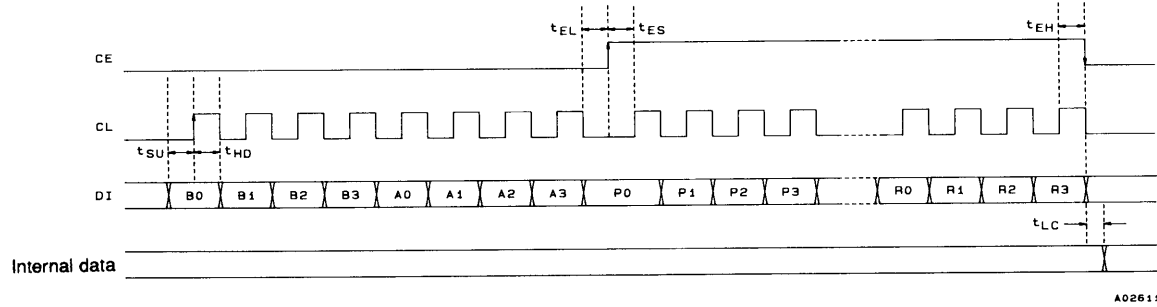

6. Serial Data Output (OUT) $t_{SU}, t_{HD}, t_{EL}, t_{ES}, t_{EH} \geq 0.75 \mu s, t_{DC}, t_{DH} \leq 0.35 \mu s^*$

① CL: Normal high

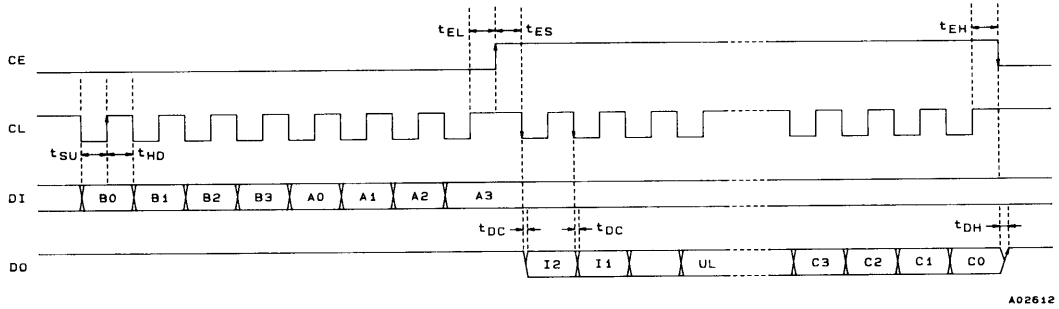

② CL: Normal low

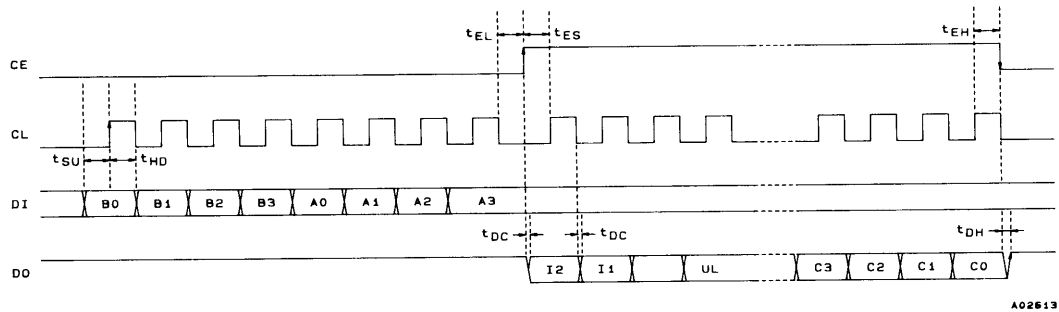

Note: Since the DO pin is an n-channel open-drain pin, the time for the data to change (t_{DC} and t_{DH}) will differ depending on the value of the pull-up resistor and the printed circuit board capacitance.

LC72135M

7. Serial Data Timing

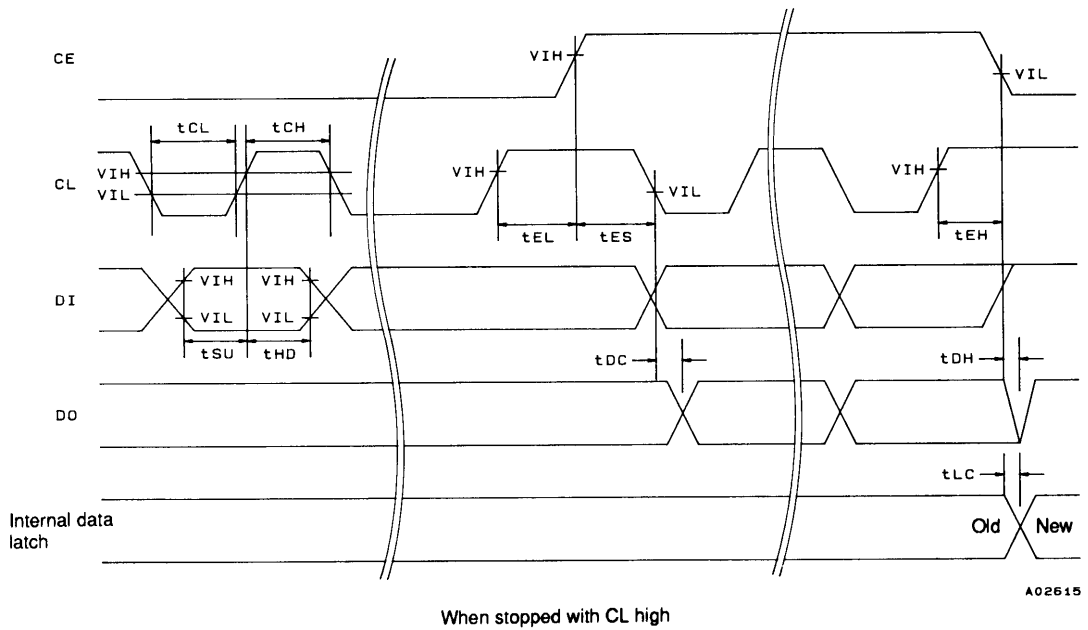
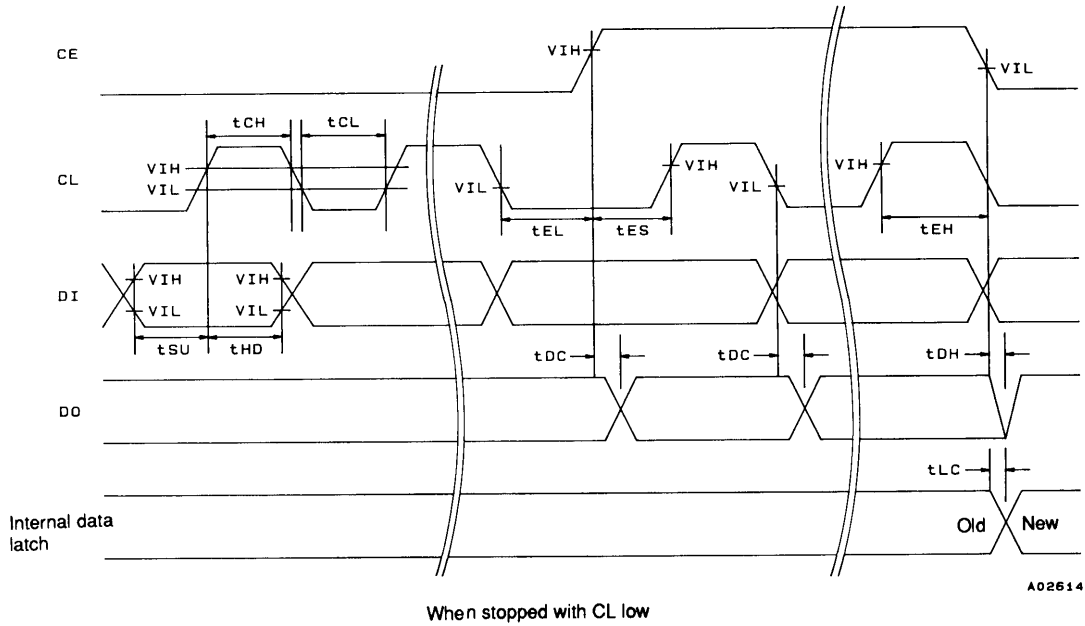

Parameter	Symbol	Pins	Conditions	min	typ	max	Unit
Data setup time	t_{SU}	DI, CL		0.75			μs
Data hold time	t_{HD}	DI, CL		0.75			μs
Clock low-level time	t_{CL}	CL		0.75			μs
Clock high-level time	t_{CH}	CL		0.75			μs
CE wait time	t_{EL}	CE, CL		0.75			μs
CE setup time	t_{ES}	CE, CL		0.75			μs
CE hold time	t_{EH}	CE, CL		0.75			μs
Data latch change time	t_{LC}					0.75	μs
Data output time	t_{DC}	DO, CL	Differs depending on the value of the pull-up resistor and the printed circuit board capacitances.			0.35	μs
	t_{DH}	DO, CE					

Programmable Divider Structure

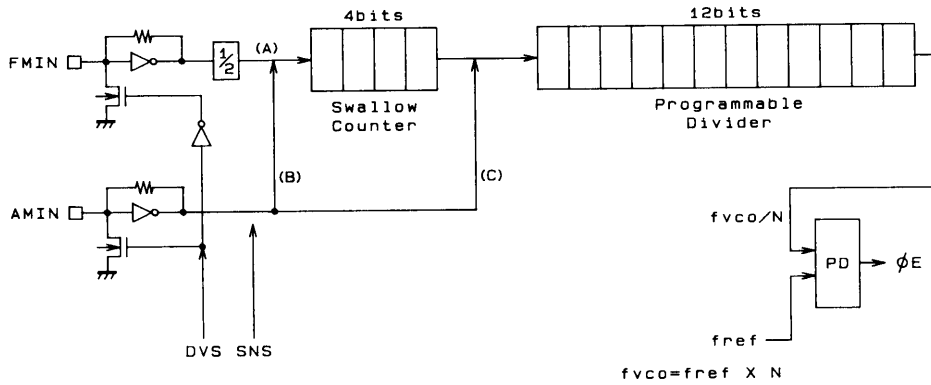

A02616

	DVS	SNS	Input pin	Set divisor	Actual divisor: N	Input frequency range (MHz)
A	1	*	FMIN	272 to 65535	Twice the set value	10 to 160
B	0	1	AMIN	272 to 65535	The set value	2 to 40
C	0	0	AMIN	4 to 4095	The set value	0.5 to 10

Note: * Don't care.

1. Programmable Divider Calculation Examples

- FM, 50 kHz steps (DVS = 1, SNS = *, FMIN selected)
 FM RF = 90.0 MHz (IF = +10.7 MHz)
 FM VCO = 100.7 MHz
 PLL fref = 25 kHz (R0 to R1 = 1, R2 to R3 = 0)
 $100.7 \text{ MHz (FM VCO)} \div 25 \text{ kHz (fref)} \div 2 \text{ (FMIN: divide-by-two prescaler)} = 2014 \rightarrow 07DE \text{ (HEX)}$

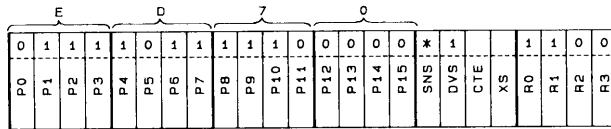

A02617

- SW, 5 kHz steps (DVS = 0, SNS = 1, AMIN high-speed side selected)
 SW RF = 21.75 MHz (IF = +450 kHz)
 SW VCO = 22.20 MHz
 PLL fref = 5 kHz (R0 = R2 = 0, R1 = R3 = 1)
 $22.2 \text{ MHz (SW VCO)} \div 5 \text{ kHz (fref)} = 4440 \rightarrow 1158 \text{ (HEX)}$

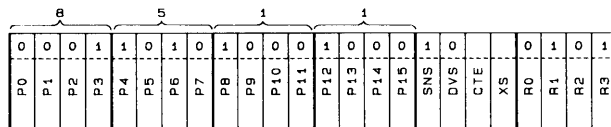

A02618

- MW, 10 kHz steps (DVS = 0, SNS = 0, AMIN low-speed side selected)
 MW RF = 1000 kHz (IF = +450 kHz)
 MW VCO = 1450 kHz
 PLL fref = 10 kHz (R0 to R2 = 0, R3 = 1)
 $1450 \text{ kHz (MW VCO)} \div 10 \text{ kHz (fref)} = 145 \rightarrow 091 \text{ (HEX)}$

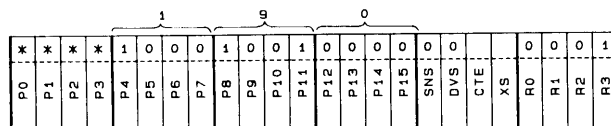

A02619

IF Counter Structure

The LC72135M IF counter is a 20-bit binary counter that accepts an IF input from either the HCTR pin (for FM or AM IF counting) or the LCTR/I1 pin (for AM IF counting). The result of the count can be read out serially through the DO pin starting with the MSB.

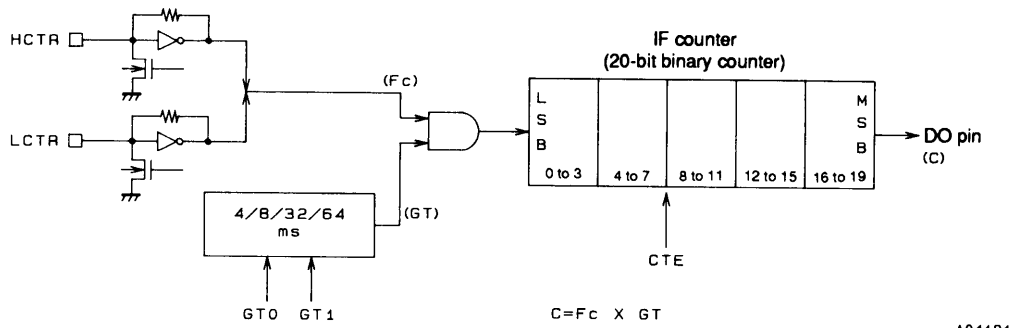

GT1	GT0	Measurement time	
		Measurement period (GT) (ms)	Wait time (t _{WU}) (ms)
0	0	4	3 to 4
0	1	8	3 to 4
1	0	32	7 to 8
1	1	64	7 to 8

The IF frequency (Fc) is measured by determining how many pulses were input to an IF counter in a specified measurement period, GT.

$$F_c = \frac{C}{GT} \quad (C = F_c \times GT) \quad C: \text{Count value (number of pulses)}$$

1. IF Counter Frequency Calculation Examples

- When the measurement period (GT) is 32 ms, the count (C) is 53980 hexadecimal (342400 decimal):
IF frequency (Fc) = 342400 ÷ 32 ms = 10.7 MHz

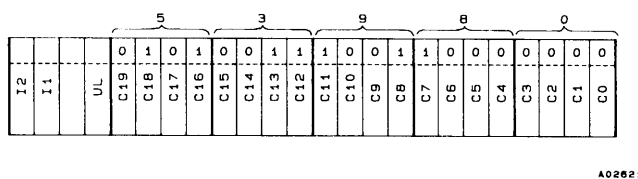

- When the measurement period (GT) is 8 ms, the count (C) is E10 hexadecimal (3600 decimal):
IF frequency (Fc) = 3600 ÷ 8 ms = 450 kHz

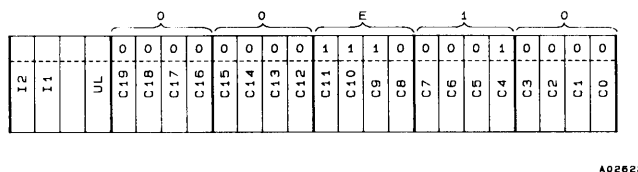

2. IF Counter Operation

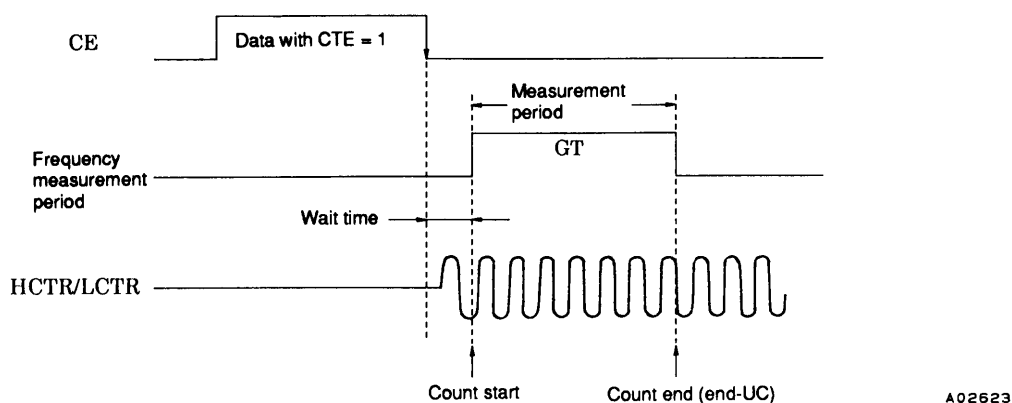

Before starting the IF count, the IF counter must be reset in advance by setting CTE in the serial data to 0.

The IF count is started by changing the CTE bit in the serial data from 0 to 1. The serial data is latched by the LC72135M when the CE pin is dropped from high to low. The IF signal must be supplied to the HCTR and LCTR pins in the period between the point the CE pin goes low and the end of the wait time at the latest. Next, the value of the IF counter at the end of the measurement period must be read out during the period that CTE is 1. This is because the IF counter is reset when CTE is set to 0.

Note: When operating the IF counter, the control microprocessor must first check the state of the IF-IC SD (station detect) signal and only after determining that the SD signal is present turn on IF buffer output and execute an IF count operation. Autosearch techniques that use only the IF counter are not recommended, since it is possible for IF buffer leakage output to cause incorrect stops at points where there is no station.

Note that the LC72135M input sensitivity can be controlled with the IFS bit in the serial data.

Reduced sensitivity mode (IFS = 0) must be selected when this IC is used in conjunction with an IF-IC that does not provide an SD output and auto-search is implemented using only IF counting.

HCTR minimum input sensitivity standard

IFS	f (MHz)		
	0.4 ≤ f < 0.5	0.5 ≤ f < 8	8 ≤ f ≤ 12
1: Normal mode	40 mVrms (0.1 to 3 mVrms)	40 mVrms	40 mVrms (1 to 10 mVrms)
0: Degradation mode	70 mVrms (10 to 15 mVrms)	70 mVrms	70 mVrms (30 to 40 mVrms)

Note: Values in parentheses are actual performance values presented as reference data.

Unlock Detection Timing

1. Unlock Detection Determination Timing

Unlocked state detection is performed in the reference frequency (f_{ref}) period (interval). Therefore, in principle, unlock determination requires a time longer than the period of the reference frequency. However, immediately after changing the divisor N (frequency) unlock detection must be performed after waiting at least two periods of the reference frequency.

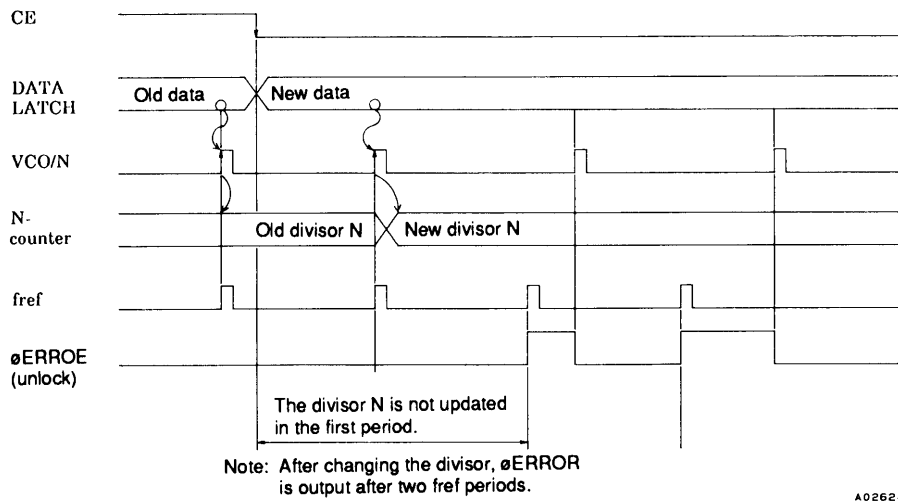

Figure 1 Unlocked State Detection Timing

For example, if f_{ref} is 1 kHz, i.e., the period is 1 ms, after changing the divisor N, the system must wait at least 2 ms before checking for the unlocked state.

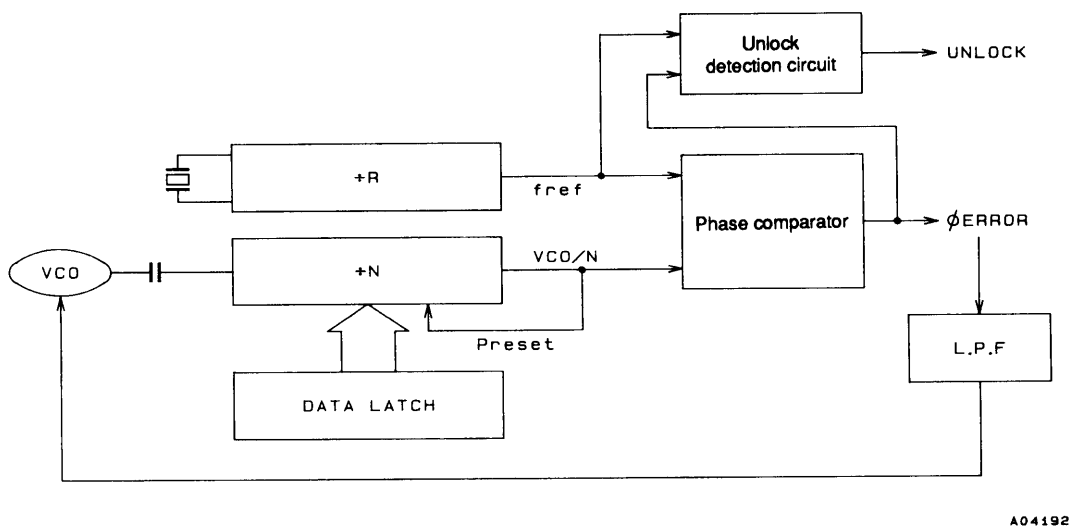

Figure 2 Circuit Structure

2. Unlock Detection Software

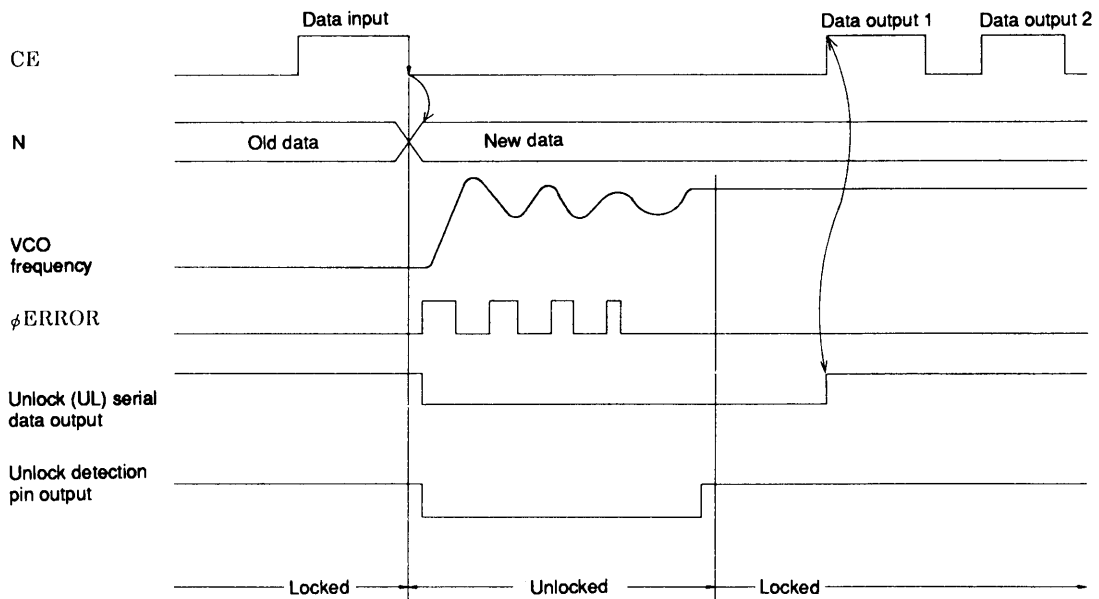

Figure 3

A02626

3. Unlocked State Data Output Using Serial Data Output

In the LC72135M, once an unlocked state occurs, the unlocked state serial data (UL) will not be reset until a data input (or output) operation is performed. At the data output ① point in Figure 3, although the VCO frequency has stabilized (locked), since no data output has been performed since the divisor N was changed the unlocked state data remains in the unlocked state. As a result, even though the frequency has stabilized (locked), the system remains (from the standpoint of the data) in the unlocked state.

Therefore, the unlocked state data acquired at data output ①, which occurs immediately after the divisor N was changed, should be treated as a dummy data output and ignored. The second data output (data output ②) and following outputs are valid data.

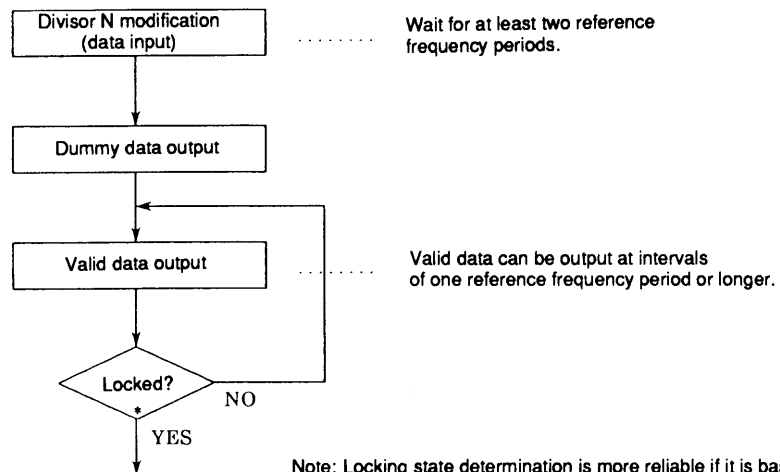

Note: Locking state determination is more reliable if it is based on reading valid output data several times.

Locked State Determination Flowchart

4. Directly Outputting Unlocked State Data from the DO Pin (Set by the DO pin control data)

Since the locking state (high = locked, low = unlocked) is output directly from the DO pin, the dummy data processing described in section 3 above is not required. After changing the divisor N, the locking state can be checked after waiting at least two reference frequency periods.

Clock Time Base Usage Notes

The pull-up resistor used on the clock time base output pin (BO1) should be at least 100 kΩ.

This is to prevent degrading the VCO C/N characteristics when a loop filter is formed using the built-in low-pass filter transistor. Since the clock time base output pin and the low-pass filter have a common ground internal to the IC, it is necessary to minimize the time base output pin current fluctuations and to suppress their influence on the low-pass filter. Also, to prevent chattering we recommend using a Schmitt input at the controller (microprocessor) that receives this signal.

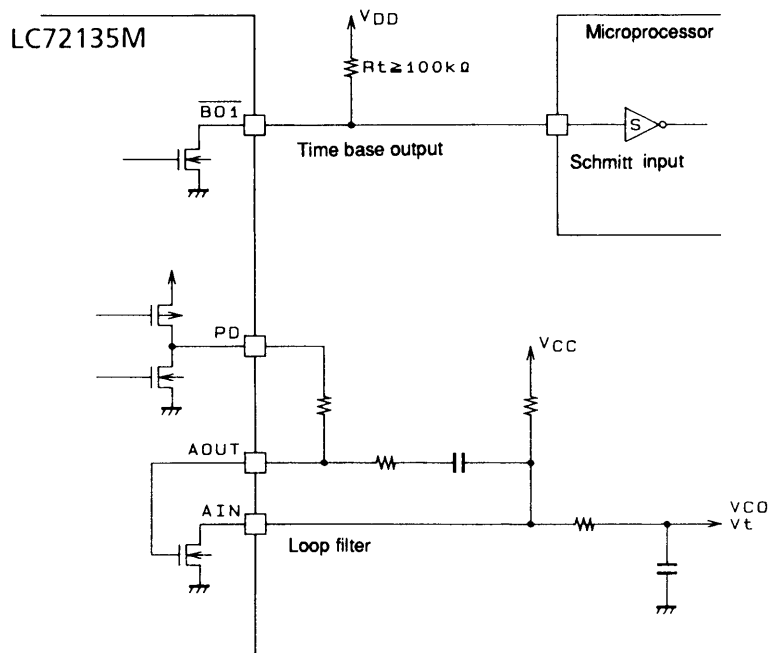

Other Items

A04193

DZ1	DZ0	Dead zone mode	Charge pump	Dead zone
0	0	DZA	ON/ON	- -0 s
0	1	DZB	ON/ON	-0 s
1	0	DZC	OFF/OFF	+0 s
1	1	DZD	OFF/OFF	+ +0 s

1. Notes on the Phase Comparator Dead Zone

Since correction pulses are output from the charge pump even if the PLL is locked when the charge pump is in the ON/ON state, the loop can easily become unstable. This point requires special care when designing application circuits.

The following problems may occur in the ON/ON state.

- Side band generation due to reference frequency leakage
- Side band generation due to both the correction pulse envelope and low frequency leakage

Schemes in which a dead zone is present (OFF/OFF) have good loop stability, but have the problem that acquiring a high C/N ratio can be difficult. On the other hand, although it is easy to acquire a high C/N ratio with schemes in which there is no dead zone, it is difficult to achieve high loop stability. Therefore, it can be effective to select DZA or DZB, which have no dead zone, in applications which require an FM S/R ratio in excess of 90 to 100 dB, or in which an increased AM stereo pilot margin is desired. On the other hand, we recommend selecting DZC or DZD, which provide a dead zone, for applications which do not require such a high FM signal-to-noise ratio and in which either AM stereo is not used or an adequate AM stereo pilot margin can be achieved.

Dead Zone

The phase comparator compares f_p to a reference frequency (f_r) as shown in Figure 4. Although the characteristics of this circuit (see Figure 5) are such that the output voltage is proportional to the phase difference ϕ (line A), a region (the dead zone) in which it is not possible to compare small phase differences occurs in actual ICs due to internal circuit delays and other factors (line B). A dead zone as small as possible is desirable for products that must provide a high S/N ratio.

However, since a larger dead zone makes this circuit easier to use, a larger dead zone is appropriate for popularly-priced products. This is because it is possible for RF signals to leak from the mixer to the VCO and modulate the VCO in popularly-priced products in the presence of strong RF inputs. When the dead zone is narrow, the circuit outputs correction pulses and this output can further modulate the VCO and generate beat frequencies with the RF signal.

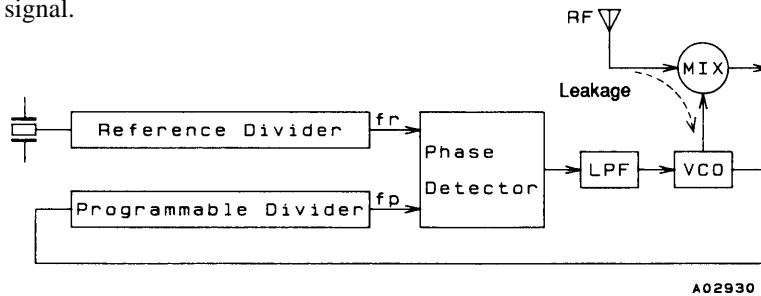

Figure 4

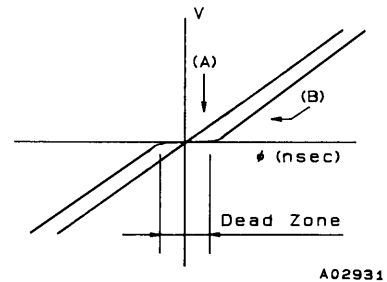

Figure 5

2. Notes on the FMIN, AMIN, HCTR and LCTR/I1 Pins

Coupling capacitors must be placed as close as possible to their respective pins. A capacitance of about 100 pF is desirable. In particular, if a capacitance of 1000 pF or over is used for the HCTR and LCTR/I1 pins, the time to reach the bias level will increase and incorrect counting may occur due to the relationship with the wait time.

3. Notes on IF Counting → SD must be used in conjunction with the IF counting time

When using IF counting, always implement IF counting by having the microprocessor determine the presence of the IF-IC SD (station detect) signal and turn on the IF counter buffer only if the SD signal is present. Schemes in which auto-searches are performed with only IF counting are not recommended, since they can stop at points where there is no signal due to leakage output from the IF counter buffer.

4. DO Pin Usage Techniques

In addition to data output mode times, the DO pin can also be used to check for IF counter count completion and for unlock detection output. Also, an input pin state can be output unchanged through the DO pin and input to the controller.

5. Power Supply Pins

A capacitor of at least 2000 pF must be inserted between the power supply V_{DD} and V_{SS} pins for noise exclusion. This capacitor must be placed as close as possible to the V_{DD} and V_{SS} pins.

6. VCO Setup

Applications must be designed so that the VCO (local oscillator) does not stop, even if the control voltage (V_{tune}) goes to 0 V. If it is possible for the oscillator to stop, the application must use the control data (DLC) to temporarily force V_{tune} to V_{CC} to prevent deadlock from occurring. (Deadlock clear circuit)

LC72135M

Pin States after the Power ON Reset

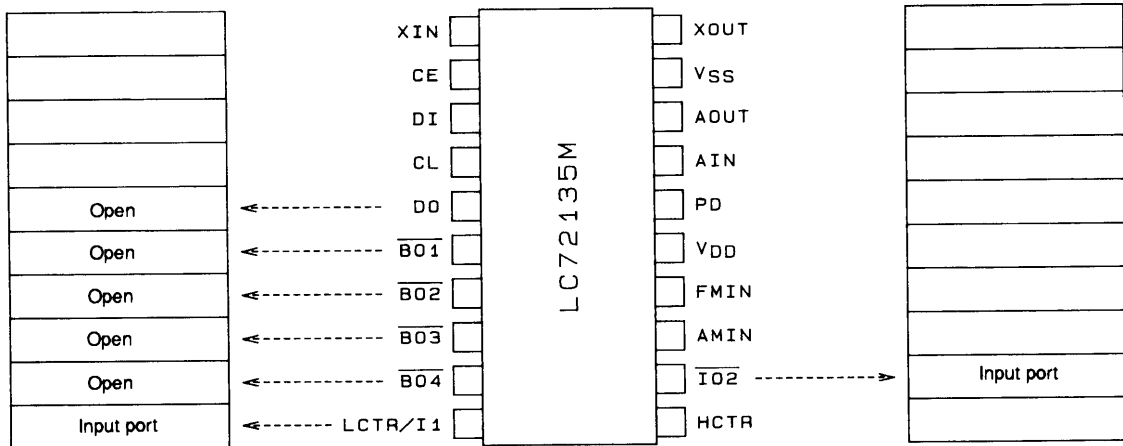

A04194

Application System Example

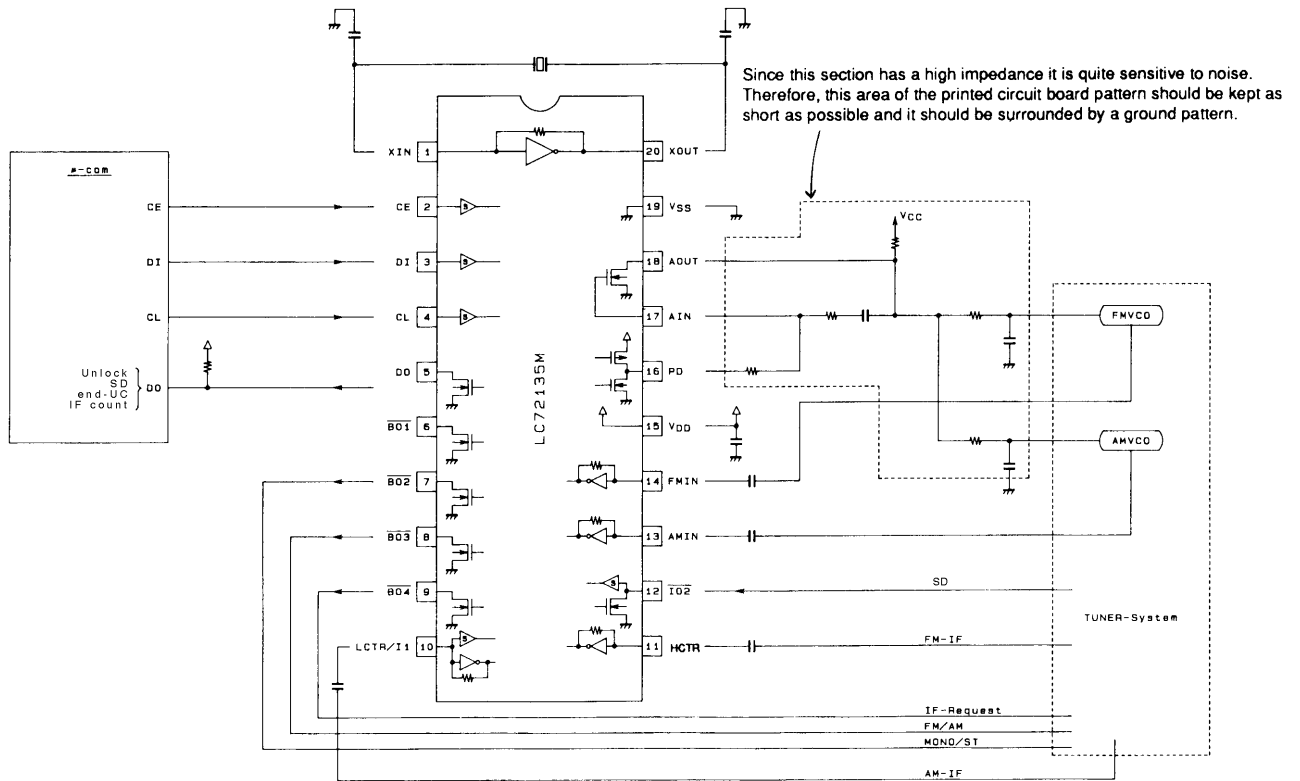

A04195

- Specifications of any and all SANYO products described or contained herein stipulate the performance, characteristics, and functions of the described products in the independent state, and are not guarantees of the performance, characteristics, and functions of the described products as mounted in the customer's products or equipment. To verify symptoms and states that cannot be evaluated in an independent device, the customer should always evaluate and test devices mounted in the customer's products or equipment.
- SANYO Electric Co., Ltd. strives to supply high-quality high-reliability products. However, any and all semiconductor products fail with some probability. It is possible that these probabilistic failures could give rise to accidents or events that could endanger human lives, that could give rise to smoke or fire, or that could cause damage to other property. When designing equipment, adopt safety measures so that these kinds of accidents or events cannot occur. Such measures include but are not limited to protective circuits and error prevention circuits for safe design, redundant design, and structural design.
- In the event that any and all SANYO products described or contained herein fall under strategic products (including services) controlled under the Foreign Exchange and Foreign Trade Control Law of Japan, such products must not be exported without obtaining export license from the Ministry of International Trade and Industry in accordance with the above law.
- No part of this publication may be reproduced or transmitted in any form or by any means, electronic or mechanical, including photocopying and recording, or any information storage or retrieval system, or otherwise, without the prior written permission of SANYO Electric Co., Ltd.
- Any and all information described or contained herein are subject to change without notice due to product/technology improvement, etc. When designing equipment, refer to the "Delivery Specification" for the SANYO product that you intend to use.
- Information (including circuit diagrams and circuit parameters) herein is for example only; it is not guaranteed for volume production. SANYO believes information herein is accurate and reliable, but no guarantees are made or implied regarding its use or any infringements of intellectual property rights or other rights of third parties.

This catalog provides information as of August, 1998. Specifications and information herein are subject to change without notice.