

# Silicon NPN High Voltage Switching Transistor

## Features

- Simple-sWitch-Off Transistor (SWOT)
- HIGH SPEED technology
- Planar passivation
- 100 kHz switching rate
- Very low switching losses
- Very low dynamic saturation
- Very low operating temperature
- Optimized RBSOA
- High reverse voltage

## Applications

Electronic lamp ballast circuits

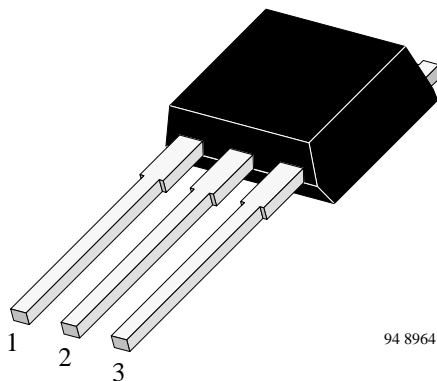

BUD7312 1 Base 2 Collector 3 Emitter

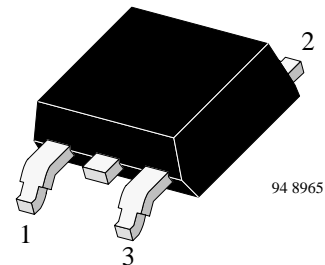

BUD7312 –SMD 1 Base 2 Collector 3 Emitter

## Absolute Maximum Ratings

$T_{case} = 25^{\circ}C$ , unless otherwise specified

Parameter	Test Conditions	Symbol	Value	Unit
Collector-emitter voltage		$V_{CEO}$	600	V
		$V_{CES}$	1200	V
Emitter-base voltage		$V_{EBO}$	9	V
Collector current		$I_C$	3	A
Collector peak current		$I_{CM}$	5	A
Base current		$I_B$	2	A
Base peak current		$I_{BM}$	4	A
Total power dissipation	$T_{case} = 25^{\circ}C$	$P_{tot}$	40	W
Junction temperature		$T_j$	150	$^{\circ}C$
Storage temperature range		$T_{stg}$	-65 to +150	$^{\circ}C$

### Maximum Thermal Resistance

$T_{\text{case}} = 25^{\circ}\text{C}$ , unless otherwise specified

Parameter	Test Conditions	Symbol	Value	Unit
Junction case		$R_{\text{thJC}}$	3.12	K/W

### Electrical Characteristics

$T_{\text{case}} = 25^{\circ}\text{C}$ , unless otherwise specified

Parameter	Test Conditions	Symbol	Min	Typ	Max	Unit
Collector cut-off current	$V_{\text{CE}} = 1200 \text{ V}$	$I_{\text{CES}}$			100	$\mu\text{A}$
	$V_{\text{CE}} = 1200 \text{ V}; T_{\text{case}} = 150^{\circ}\text{C}$	$I_{\text{CES}}$			1	$\text{mA}$
Collector-emitter breakdown voltage (figure 1)	$I_{\text{C}} = 300 \text{ mA}; L = 125 \text{ mH}; I_{\text{measure}} = 100 \text{ mA}$	$V_{(\text{BR})\text{CEO}}$	550			V
Emitter cut-off current	$V_{\text{EB}} = 9 \text{ V}$	$I_{\text{EBO}}$			10	$\mu\text{A}$
Collector-emitter saturation voltage	$I_{\text{C}} = 0.5 \text{ A}; I_{\text{B}} = 0.13 \text{ A}$	$V_{\text{CEsat}}$			0.25	V
	$I_{\text{C}} = 1.5 \text{ A}; I_{\text{B}} = 0.5 \text{ A}$	$V_{\text{CEsat}}$			0.5	V
Base-emitter saturation voltage	$I_{\text{C}} = 0.5 \text{ A}; I_{\text{B}} = 0.13 \text{ A}$	$V_{\text{BEsat}}$			1	V
	$I_{\text{C}} = 1.5 \text{ A}; I_{\text{B}} = 0.5 \text{ A}$	$V_{\text{BEsat}}$			1.1	V
DC forward current transfer ratio	$V_{\text{CE}} = 2 \text{ V}; I_{\text{C}} = 10 \text{ mA}$	$h_{\text{FE}}$	15			
	$V_{\text{CE}} = 2 \text{ V}; I_{\text{C}} = 0.5 \text{ A}$	$h_{\text{FE}}$	12			
	$V_{\text{CE}} = 2 \text{ V}; I_{\text{C}} = 1.5 \text{ A}$	$h_{\text{FE}}$	6			
	$V_{\text{CE}} = 5 \text{ V}; I_{\text{C}} = 3 \text{ A}$	$h_{\text{FE}}$	4			
Collector-emitter working voltage	$I_{\text{C}} = 3 \text{ A}; I_{\text{B1}} = 1 \text{ A}; -I_{\text{B2}} = 0.3 \text{ A}$	$V_{\text{CEW}}$	650			V
Dynamic saturation voltage	$I_{\text{C}} = 1.5 \text{ A}; I_{\text{B}} = 0.3 \text{ A}; t = 1 \mu\text{s}$	$V_{\text{CEsatdyn}}$			15	V
	$I_{\text{C}} = 1.5 \text{ A}; I_{\text{B}} = 0.3 \text{ A}; t = 3 \mu\text{s}$	$V_{\text{CEsatdyn}}$			7.5	V

### Switching Characteristics

$T_{case} = 25^{\circ}C$ , unless otherwise specified

Parameter	Test Conditions	Symbol	Min	Typ	Max	Unit
Resistive load (figure 2)						
Turn on time	$I_C = 0.5\text{ A}; I_{B1} = 0.13\text{ A}; -I_{B2} = 0.25\text{ A}$	$t_{on}$			0.5	$\mu s$
Storage time		$t_s$			4	$\mu s$
Fall time		$t_f$			0.5	$\mu s$
Turn on time	$I_C = 1.5\text{ A}; I_{B1} = 0.3\text{ A}; -I_{B2} = 0.75\text{ A}$	$t_{on}$			0.8	$\mu s$
Storage time		$t_s$			2.5	$\mu s$
Fall time		$t_f$			0.2	$\mu s$
Inductive load (figure 3)						
Storage time	$I_C = 0.5\text{ A}; I_{B1} = 0.13\text{ A}; -I_{B2} = 0.25\text{ A}$	$t_s$			4.5	$\mu s$
Fall time		$t_f$			0.35	$\mu s$
Storage time	$I_C = 1.5\text{ A}; I_{B1} = 0.3\text{ A}; -I_{B2} = 0.75\text{ A}$	$t_s$			2.5	$\mu s$
Fall time		$t_f$			0.2	$\mu s$

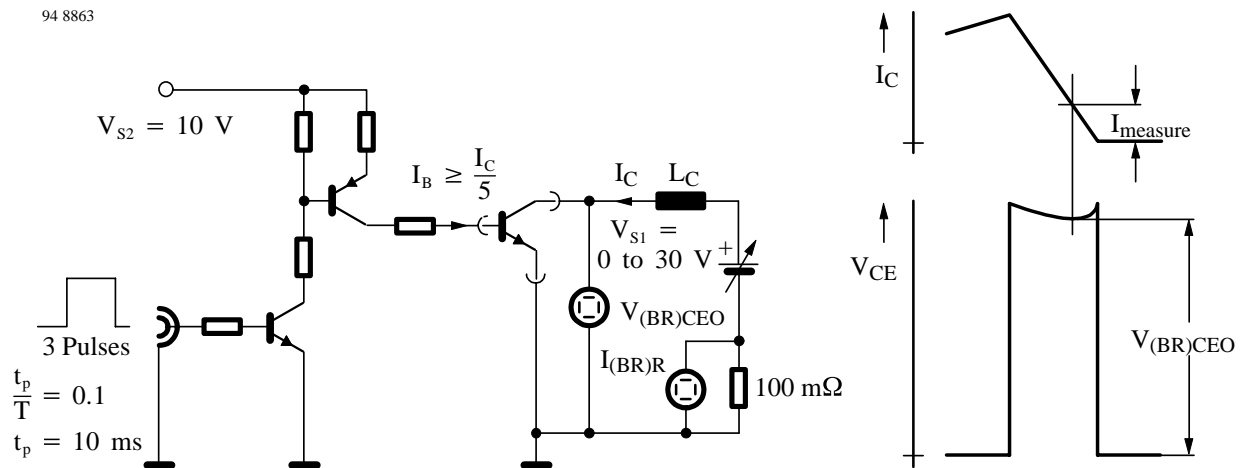
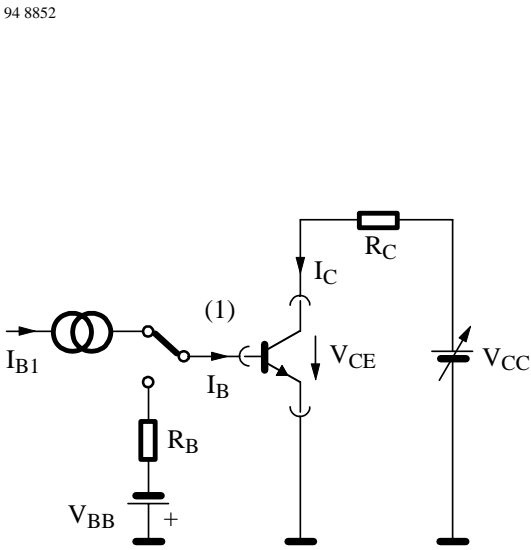

Figure 1. Test circuit for  $V_{(BR)CEO}$

94 8852



(1) Fast electronic switch

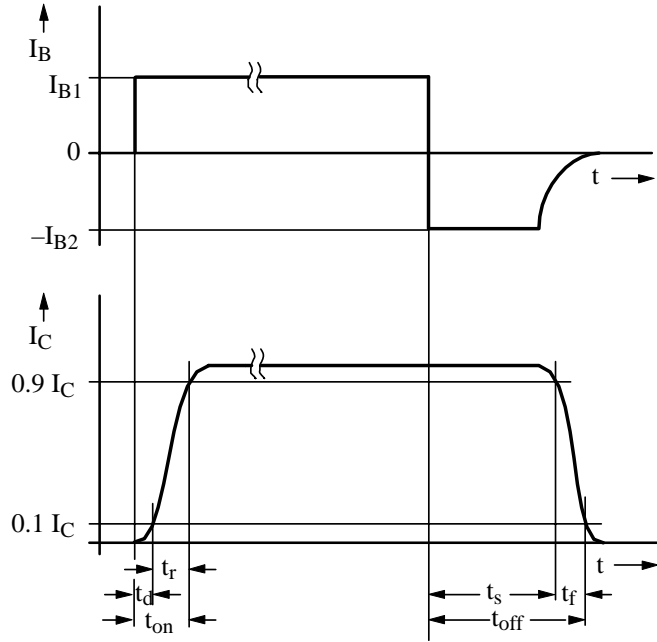
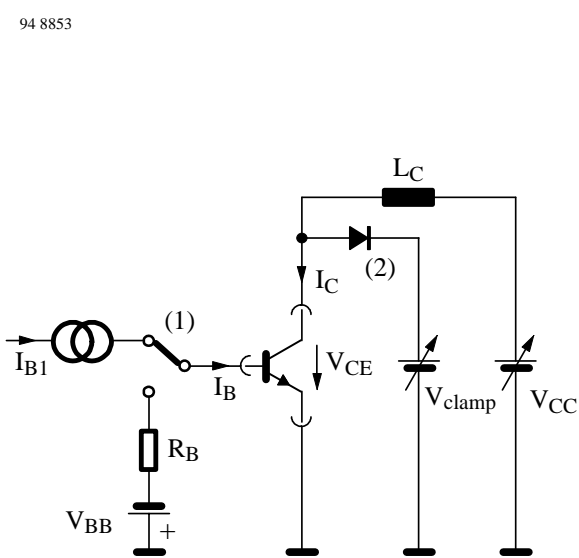

Figure 2. Test circuit for switching characteristics – resistive load

94 8853



(1) Fast electronic switch  
 (2) Fast recovery rectifier

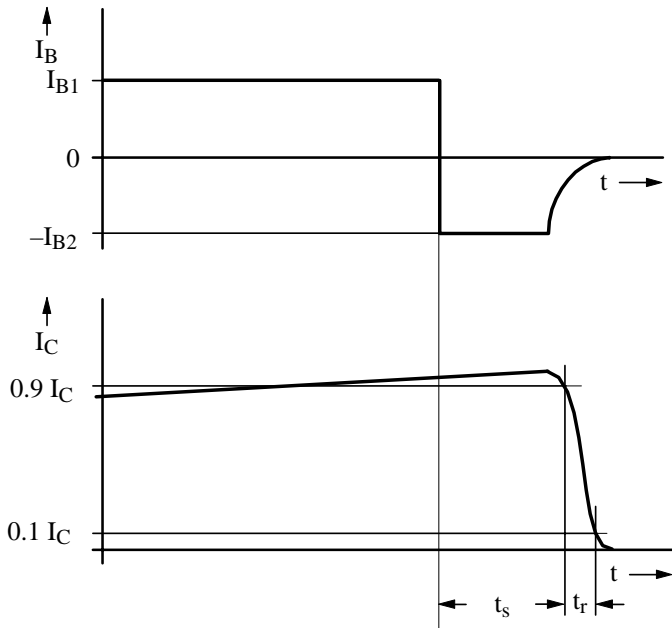

Figure 3. Test circuit for switching characteristics – inductive load

**Typical Characteristics** ( $T_{case} = 25_C$  unless otherwise specified)

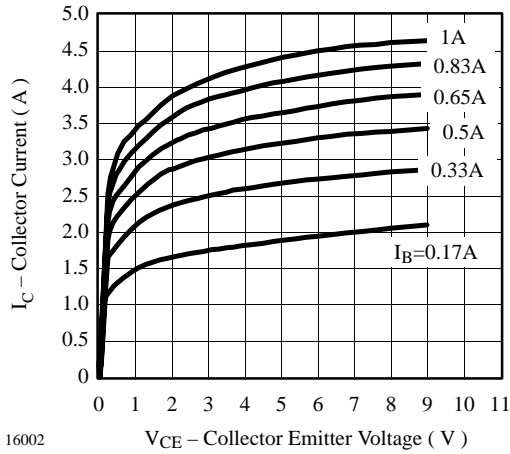

Figure 4.  $I_C$  vs.  $V_{CE}$

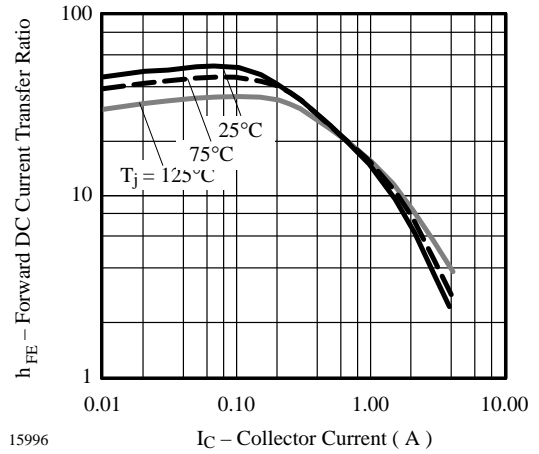

Figure 7.  $h_{FE}$  vs.  $I_C$

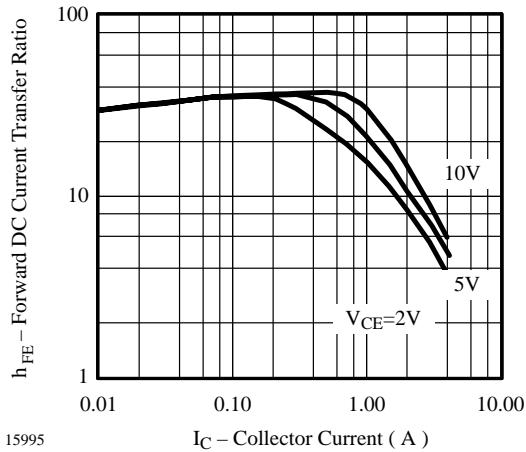

Figure 5.  $h_{FE}$  vs.  $I_C$

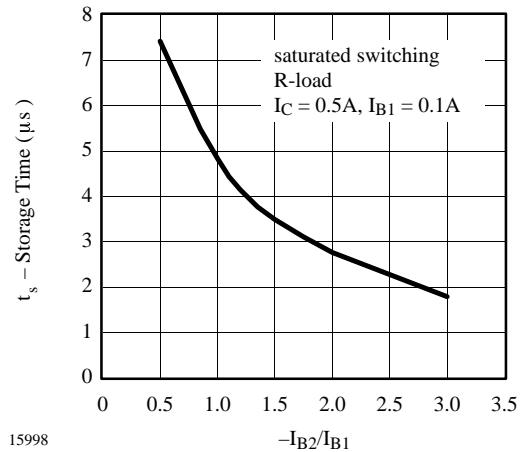

Figure 8.  $t_s$  vs.  $-I_{B2}/I_{B1}$

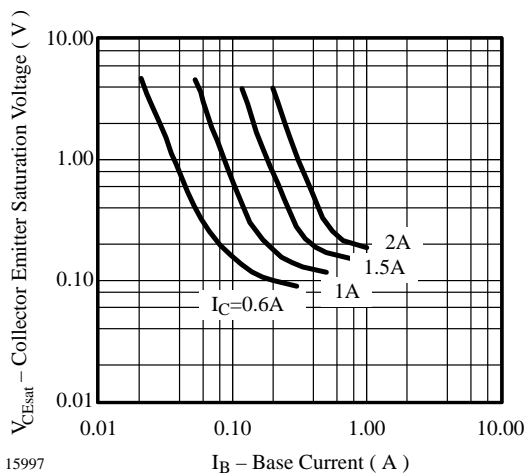

Figure 6.  $V_{CEsat}$  vs.  $I_B$

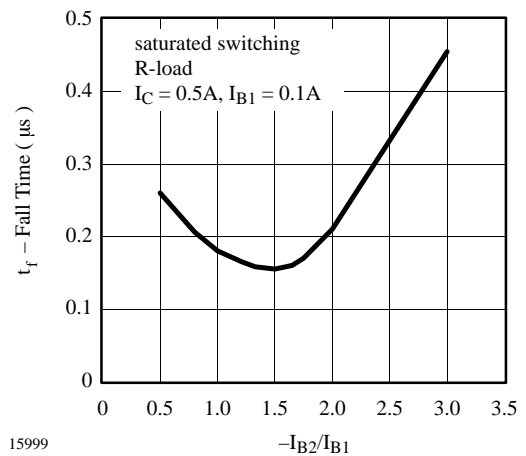
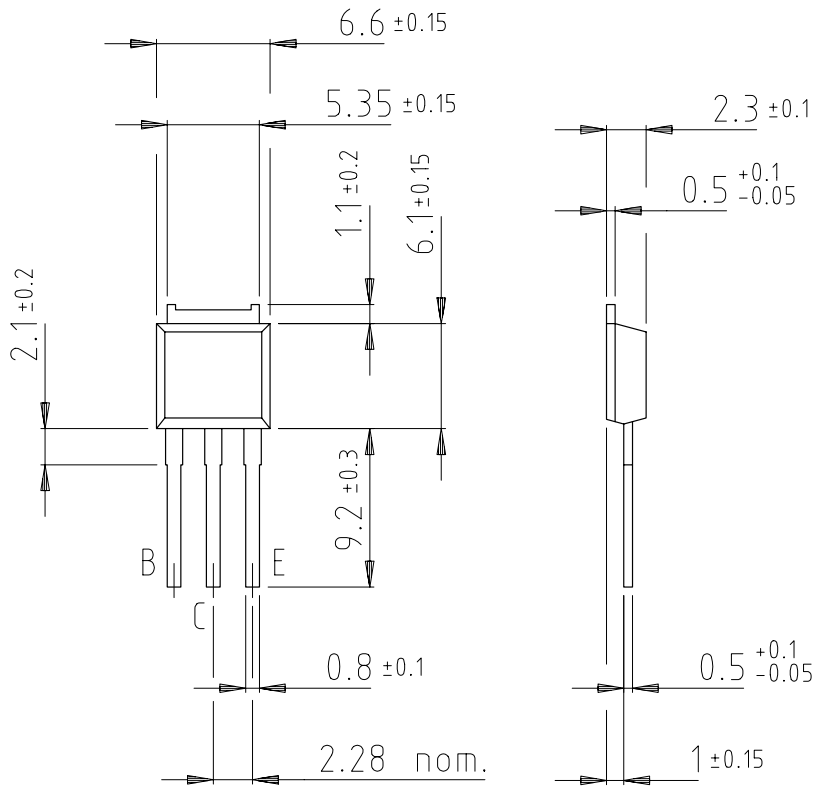
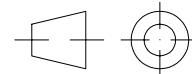

Figure 9.  $t_f$  vs.  $-I_{B2}/I_{B1}$

### Dimensions in mm



Plastic case JEDEC TO 251  
Collector connected with metallic surface



technical drawings  
according to DIN  
specifications

14292

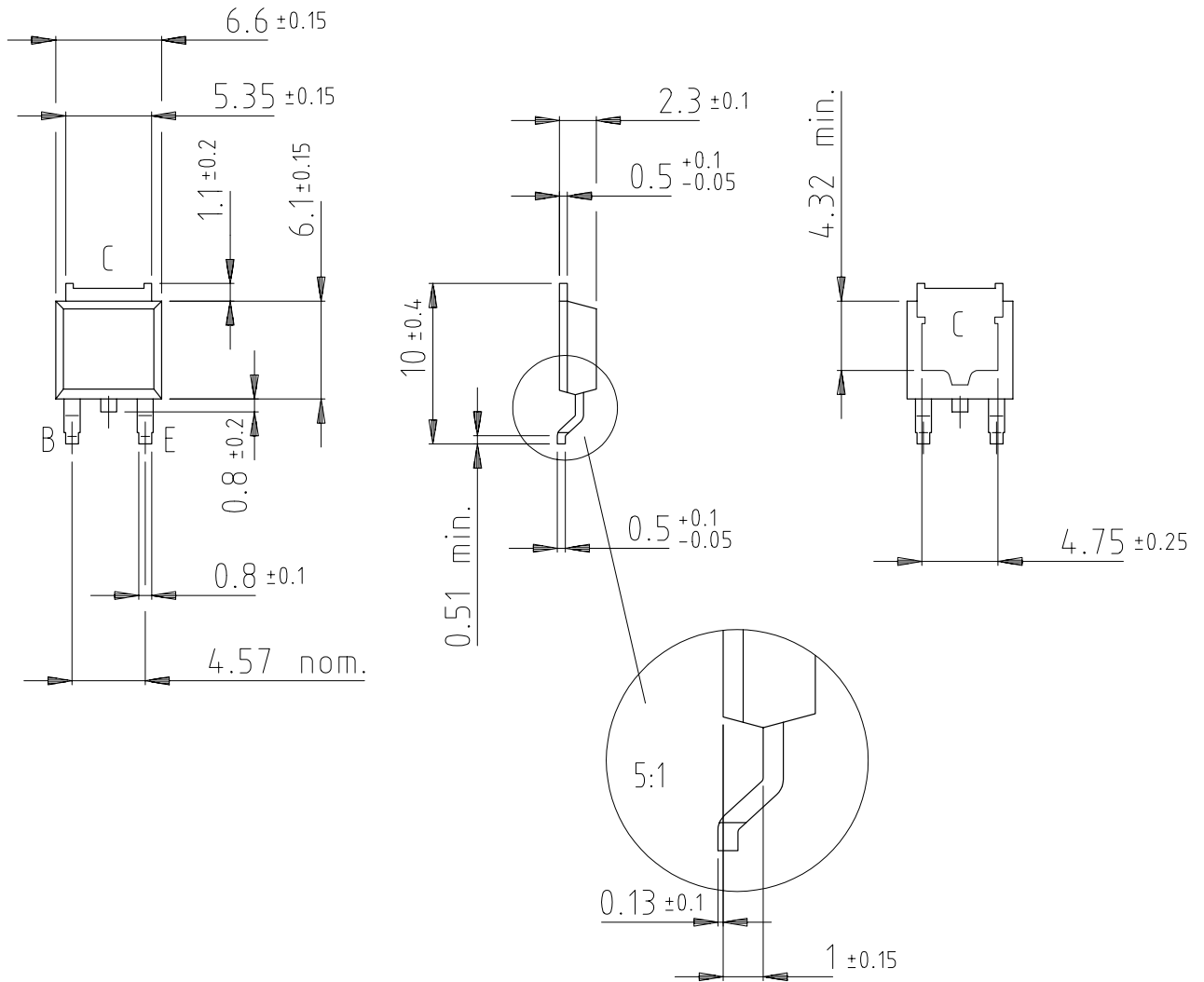

Plastic case JEDEC TO 252  
Collector connected with metallic surface

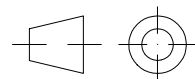

technical drawings  
according to DIN  
specifications

14293

For ordering TO 252 add SMD to the type number (i.e. BUD7312 –SMD)

### Ozone Depleting Substances Policy Statement

It is the policy of **Vishay Semiconductor GmbH** to

1. Meet all present and future national and international statutory requirements.
2. Regularly and continuously improve the performance of our products, processes, distribution and operating systems with respect to their impact on the health and safety of our employees and the public, as well as their impact on the environment.

It is particular concern to control or eliminate releases of those substances into the atmosphere which are known as ozone depleting substances (ODSs).

The Montreal Protocol (1987) and its London Amendments (1990) intend to severely restrict the use of ODSs and forbid their use within the next ten years. Various national and international initiatives are pressing for an earlier ban on these substances.

**Vishay Semiconductor GmbH** has been able to use its policy of continuous improvements to eliminate the use of ODSs listed in the following documents.

1. Annex A, B and list of transitional substances of the Montreal Protocol and the London Amendments respectively
2. Class I and II ozone depleting substances in the Clean Air Act Amendments of 1990 by the Environmental Protection Agency (EPA) in the USA
3. Council Decision 88/540/EEC and 91/690/EEC Annex A, B and C (transitional substances) respectively.

**Vishay Semiconductor GmbH** can certify that our semiconductors are not manufactured with ozone depleting substances and do not contain such substances.

**We reserve the right to make changes to improve technical design and may do so without further notice.**

Parameters can vary in different applications. All operating parameters must be validated for each customer application by the customer. Should the buyer use Vishay-Telefunken products for any unintended or unauthorized application, the buyer shall indemnify Vishay-Telefunken against all claims, costs, damages, and expenses, arising out of, directly or indirectly, any claim of personal damage, injury or death associated with such unintended or unauthorized use.

Vishay Semiconductor GmbH, P.O.B. 3535, D-74025 Heilbronn, Germany  
Telephone: 49 (0)7131 67 2831, Fax number: 49 (0)7131 67 2423