



CRYSTAL OSCILLATOR (XO) (10 MHz TO 1.4 GHz)

Features

- Available with any-rate output frequencies from 10 MHz to 945 MHz and select frequencies to 1.4 GHz
- Four selectable output frequencies
- 3rd generation DSPLL[®] with superior jitter performance
- 3x better frequency stability than SAW-based oscillators
- Internal fixed crystal frequency ensures high reliability and low aging
- Available CMOS, LVPECL, LVDS, and CML outputs
- 3.3, 2.5, and 1.8 V supply options
- Industry-standard 5 x 7 mm package and pinout
- Pb-free/RoHS-compliant

Applications

- SONET/SDH
- Networking
- SD/HD video
- Clock and data recovery
- FPGA/ASIC clock generation

Description

The Si534 quad frequency XO utilizes Silicon Laboratories' advanced DSPLL[®] circuitry to provide a low jitter clock at high frequencies. The Si534 is available with any-rate output frequency from 10 to 945 MHz and select frequencies to 1400 MHz. Unlike a traditional XO where a different crystal is required for each output frequency, the Si534 uses one fixed crystal to provide a wide range of output frequencies. This IC based approach allows the crystal resonator to provide exceptional frequency stability and reliability. In addition, DSPLL clock synthesis provides superior supply noise rejection, simplifying the task of generating low jitter clocks in noisy environments typically found in communication systems. The Si534 IC-based XO is factory configurable for a wide variety of user specifications including frequency, supply voltage, output format, and temperature stability. Specific configurations are factory programmed at time of shipment, thereby eliminating long lead times associated with custom oscillators.

Functional Block Diagram

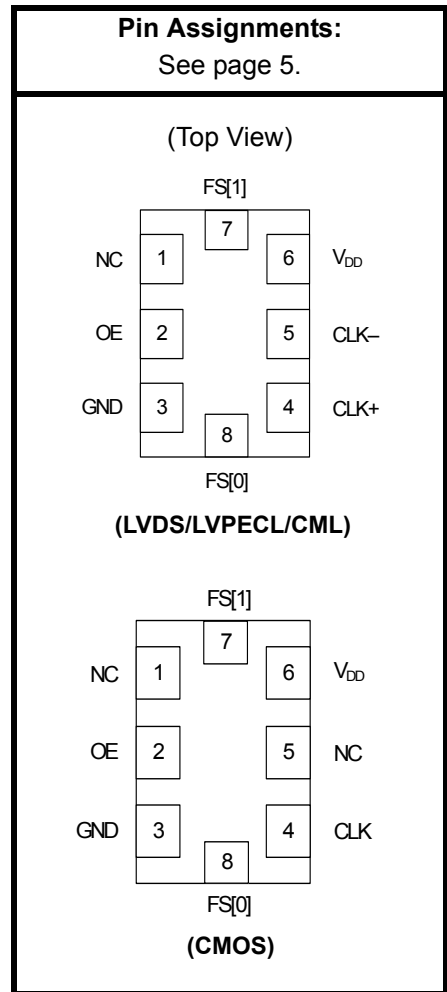
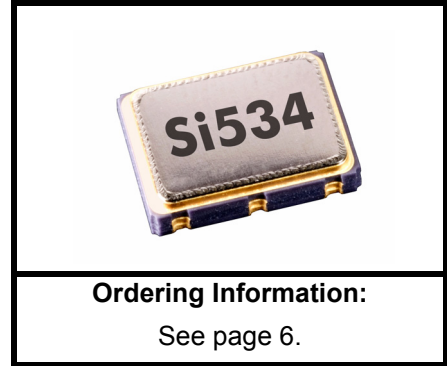
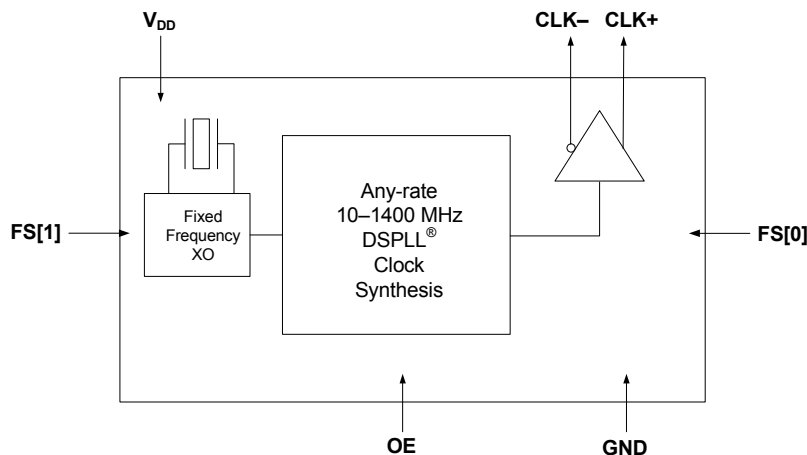

1. Electrical Specifications

Table 1. Recommended Operating Conditions

Parameter	Symbol	Test Condition	Min	Typ	Max	Units
Supply Voltage ¹	V_{DD}	3.3 V option	2.97	3.3	3.63	V
		2.5 V option	2.25	2.5	2.75	
		1.8 V option	1.71	1.8	1.89	
Supply Current	I_{DD}	Output enabled	—	90	—	mA
		TriState mode	—	60	—	
Output Enable (OE) ²		V_{IH}	$0.75 \times V_{DD}$	—	—	V
		V_{IL}	—	—	0.5	
Operating Temperature Range	T_A		−40	—	85	°C

Notes:

- Selectable parameter specified by part number. See Section 3. "Ordering Information" on page 6 for further details.
- OE pin includes a 17 k Ω pullup resistor to V_{DD} . Pulling OE to ground causes outputs to tristate.

Table 2. CLK \pm Output Frequency Characteristics

Parameter	Symbol	Test Condition	Min	Typ	Max	Units
Nominal Frequency ^{1,2}	f_O	LVPECL/LVDS/CML	10	—	945	MHz
		CMOS	10	—	160	
Initial Accuracy	f_i	Measured at +25 °C at time of shipping	—	±1.5	—	ppm
Temperature Stability ^{1,3}	$\Delta f/f_O$		−20 −50	— —	+20 +50	ppm
Aging	f_a	Frequency drift over projected 15 year life	—	—	±10	ppm
Powerup Time ⁴	t_{OSC}		—	—	10	ms
Settling Time After FS[1:0] Change	t_{FRQ}	Both FS[1] and FS[0] changing simultaneously	—	—	20	ms

Notes:

- See Section 3. "Ordering Information" on page 6 for further details.
- Specified at time of order by part number. Also available in frequencies from 970 to 1134 MHz and 1213 to 1417 MHz.
- Selectable parameter specified by part number.
- Time from powerup or tristate mode to f_O .

Table 3. CLK± Output Levels and Symmetry

Parameter	Symbol	Test Condition	Min	Typ	Max	Units
LVPECL Output Option ¹	V _O	mid-level	V _{DD} – 1.42	—	V _{DD} – 1.25	V
	V _{OD}	swing (diff)	1.1	—	1.9	V _{PP}
	V _{SE}	swing (single-ended)	0.5	—	0.93	V _{PP}
LVDS Output Option ²	V _O	mid-level	1.125	1.20	1.275	V
	V _{OD}	swing (diff)	0.32	0.40	0.50	V _{PP}
CML Output Option ²	V _O	mid-level	—	V _{DD} – 0.75	—	V
	V _{OD}	swing (diff)	0.70	0.95	1.20	V _{PP}
CMOS Output Option ³	V _{OH}	I _{OH} = 32 mA	0.8 × V _{DD}	—	V _{DD}	V
	V _{OL}	I _{OL} = 32 mA	—	—	0.4	
Rise/Fall time (20/80%)	t _R , t _F	LVPECL/LVDS/CML	—	—	350	ps
		CMOS with CL = 15 pF	—	1	—	ns
Symmetry (duty cycle)	SYM	LVPECL: V _{DD} – 1.3 V (diff) LVDS: 1.25 V (diff) CMOS: V _{DD} /2	45	—	55	%

Notes:

- 50 Ω to V_{DD} – 2.0 V.
- R_{term} = 100 Ω (differential).
- C_L = 15 pF

Table 4. CLK± Output Phase Jitter

Parameter	Symbol	Test Condition	Min	Typ	Max	Units
Phase Jitter (RMS)* for F _{OUT} ≥ 500 MHz	ϕ _J	12 kHz to 20 MHz (OC-48)	—	0.27	—	ps
		50 kHz to 80 MHz (OC-192)	—	0.30	—	
Phase Jitter (RMS)* for F _{OUT} of 125 to 500 MHz	ϕ _J	12 kHz to 20 MHz (OC-48)	—	0.50	—	ps

***Note:** Differential Modes: LVPECL/LVDS/CML. Refer to AN256 for further information.

Table 5. CLK± Output Period Jitter

Parameter	Symbol	Test Condition	Min	Typ	Max	Units
Period Jitter* for F _{OUT} ≤ 160 MHz	J _{PER}	RMS	—	1	—	ps
		Peak-to-Peak	—	5	—	

***Note:** Any output mode, including CMOS, LVPECL, LVDS, CML. N = 1000 cycles.

Table 6. CLK± Output Phase Noise (Typical)

Configuration	f_c Output	81.25 MHz LVDS	312.5 MHz LVPECL	1066 MHz LVPECL	Units
Offset Frequency (f)	$\mathcal{L}(f)$				dBc/Hz
100 Hz		-110	-100	-87	
1 kHz		-127	-115	-102	
10 kHz		-134	-119	-107	
100 kHz		-136	-123	-111	
1 MHz		-143	-135	-121	
10 MHz		-147	-144	-135	
100 MHz		n/a	-147	-142	

Table 7. Absolute Maximum Ratings¹

Parameter	Symbol	Rating	Units
Supply Voltage	V_{DD}	-0.5 to +3.8	Volts
Input Voltage (any input pin)	V_I	-0.5 to $V_{DD} + 0.3$	Volts
Storage Temperature	T_S	-55 to +125	°C
ESD Sensitivity (HBM, per JESD22-A114)	ESD	>2500	Volts
Soldering Temperature (Pb-free profile) ²	T_{PEAK}	260	°C
Soldering Temperature Time @ T_{PEAK} (Pb-free profile) ²	t_p	10	seconds
Notes:			
1. Stresses beyond those listed in Absolute Maximum Ratings may cause permanent damage to the device. Functional operation or specification compliance is not implied at these conditions.			
2. Refer to Si5xx Packaging FAQ available for download at www.silabs.com/VCXO for further information, including soldering profiles.			

Table 8. Environmental Compliance

The Si534 meets the following qualification test requirements.

Parameter	Conditions/ Test Method
Mechanical Shock	MIL-STD-883F, Method 2002.3 B
Mechanical Vibration	MIL-STD-883F, Method 2007.3 A
Solderability	MIL-STD-883F, Method 203.8
Gross & Fine Leak	MIL-STD-883F, Method 1014.7
Resistance to Solvents	MIL-STD-883F, Method 2016

2. Pin Descriptions

(Top View)

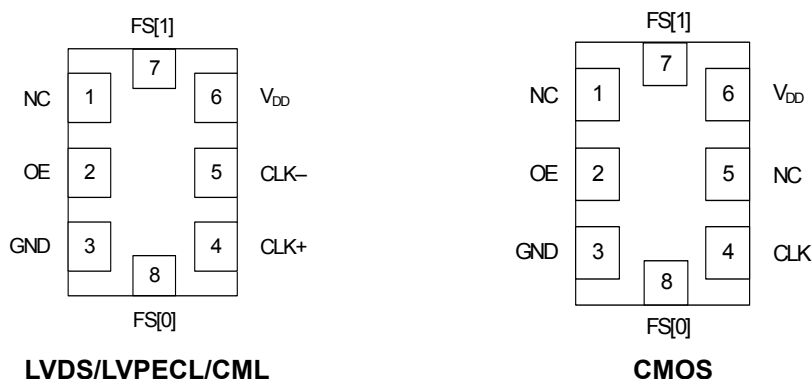

Table 9. Pin Descriptions

Pin	Symbol	LVDS/LVPECL/CML Function	CMOS Function
1	NC	No connection	No connection
2	OE*	Output enable 0 = clock output disabled (outputs tristated) 1 = clock output enabled	Output enable 0 = clock output disabled (outputs tristated) 1 = clock output enabled
3	GND	Electrical and Case Ground	Electrical and Case Ground
4	CLK+	Oscillator Output	Oscillator Output
5	CLK-	Complementary output	No connection
6	V _{DD}	Power Supply Voltage	Power Supply Voltage
7	FS[1]*	Frequency Select MSB	Frequency Select MSB
8	FS[0]*	Frequency Select LSB	Frequency Select LSB

***Note:** FS[1:0] and OE include a 17 kΩ pullup resistor to V_{DD}. See Section “Ordering Information” for details on frequency value ordering.

3. Ordering Information

The Si534 XO was designed to support a variety of options including frequency, temperature stability, output format, and V_{DD} . Specific device configurations are programmed into the Si534 at time of shipment. Configurations can be specified using the Part Number Configuration chart below. Silicon Laboratories provides a web browser-based part number configuration utility to simplify this process. Refer to www.silabs.com/VCXOPartNumber to access this tool and for further ordering instructions. The Si534 is supplied in an industry-standard, RoHS compliant, 6-pad, 5 x 7 mm package.

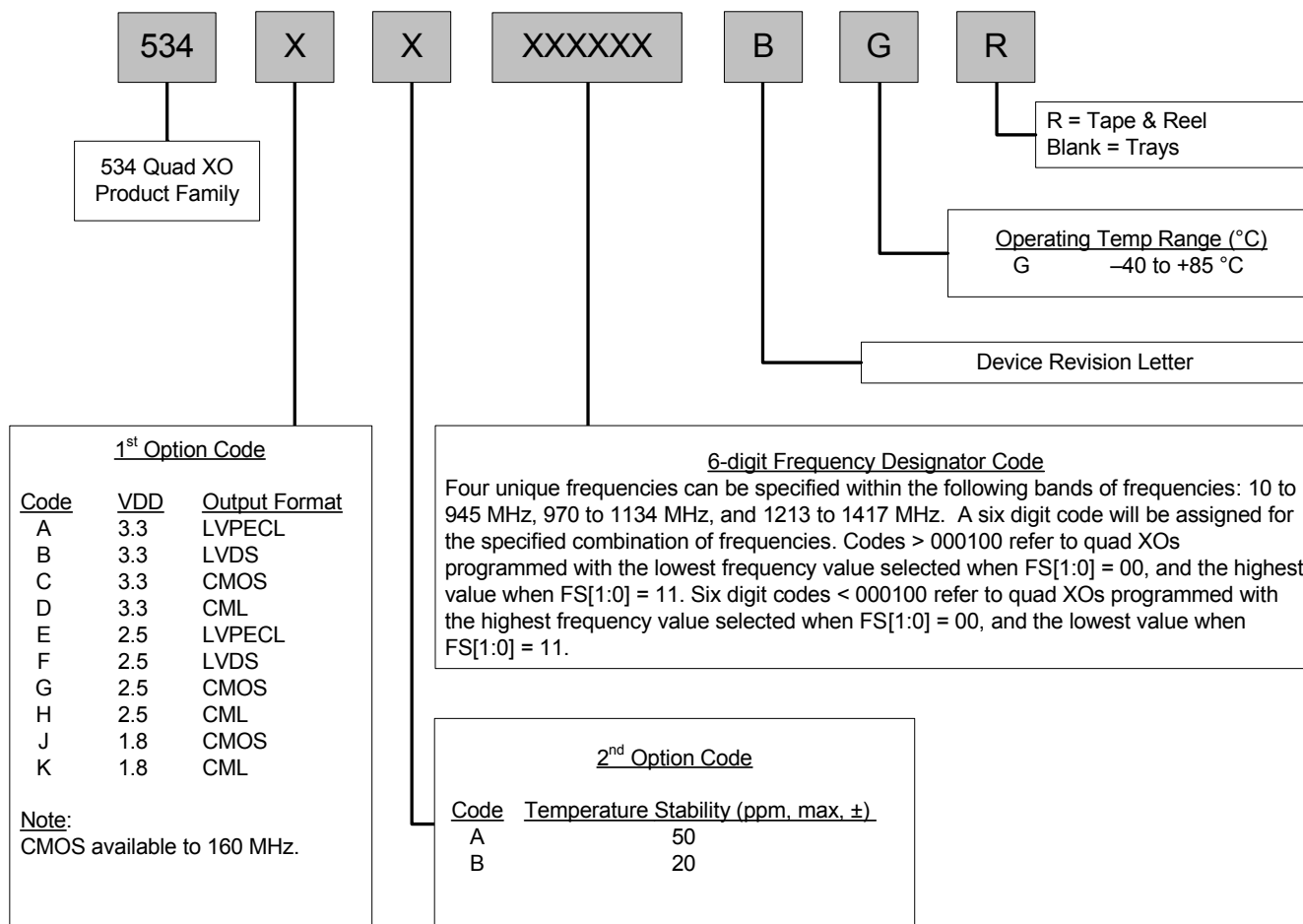

Example Part Number: 534AB000108BGR is a 5 x 7 mm quad XO in a 8 pad package. Since the six digit code (000108) is > 000100, f0 is 644.53125 MHz (lower frequency) and f1 is 693.48299 (higher frequency), with a 3.3 V supply and LVPECL output. Temperature stability is specified as ± 20 ppm. The part is specified for a -40 to +85 °C ambient temperature range operation and is shipped in tape and reel format.

Figure 1. Part Number Convention

4. Outline Diagram and Suggested Pad Layout

Figure 2 illustrates the package details for the Si534. Table 10 lists the values for the dimensions shown in the illustration.

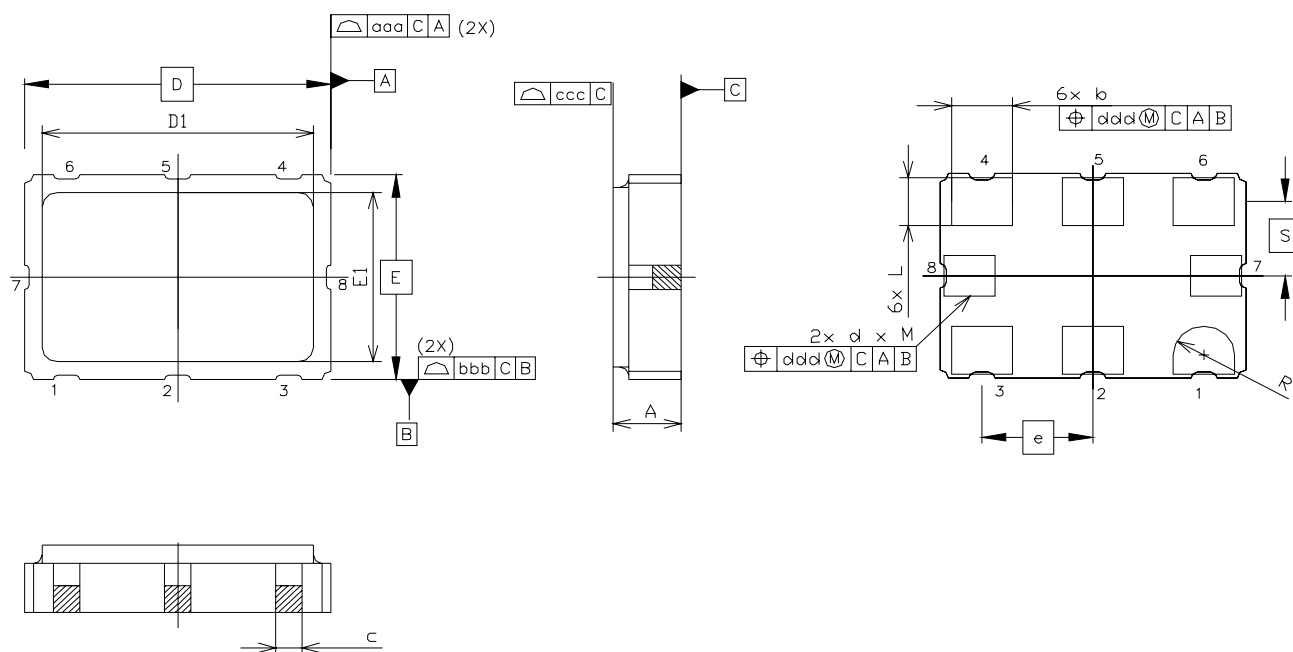

Figure 2. Si534 Outline Diagram

Table 10. Package Diagram Dimensions (mm)

Dimension	Min	Nom	Max
A	1.45	1.65	1.85
b	1.2	1.4	1.6
c	0.60 TYP		
d	0.97	1.17	1.37
D	7.00 BSC		
D1	6.10	6.2	6.30
e	2.54 BSC		
E	5.00 BSC		
E1	4.30	4.40	4.50
L	1.07	1.27	1.47
M	0.8	1.0	1.2
S	1.815 BSC		
R	0.7 REF		
aaa	—	—	0.15
bbb	—	—	0.15
ccc	—	—	0.10
ddd	—	—	0.10

5. 8-Pin PCB Land Pattern

Figure 3 illustrates the 8-pin PCB land pattern for the Si554. Table 11 lists the values for the dimensions shown in the illustration.

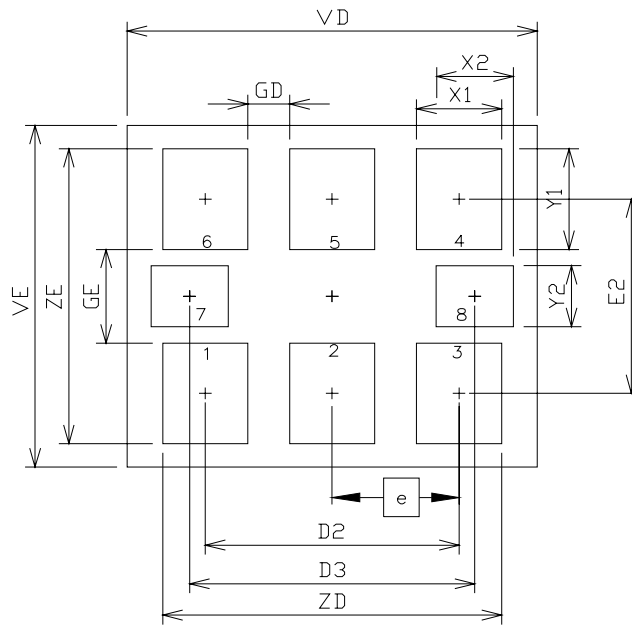

Figure 3. Si534 PCB Land Pattern

Table 11. PCB Land Pattern Dimensions (mm)

Dimension	Min	Max
D2	5.08 REF	
D3	5.705 REF	
e	2.54 BSC	
E2	4.20 REF	
GD	0.84	—
GE	2.00	—
VD	8.20 REF	
VE	7.30 REF	
X1	1.70 TYP	
X2	1.545 TYP	
Y1	2.15 REF	
Y2	1.3 REF	
ZD	—	6.78
ZE	—	6.30

Note:

1. Dimensioning and tolerancing per the ANSI Y14.5M-1994 specification.
2. Land pattern design follows IPC-7351 guidelines.
3. All dimensions shown are at maximum material condition (MMC).
4. Controlling dimension is in millimeters (mm).

DOCUMENT CHANGE LIST

Revision 0.3 to Revision 0.4

- Updated 1. "Electrical Specifications" on page 2.
 - Updated ordering and format of Tables 1–9.
 - Updated LVDS and CML in Table 3, "CLK± Output Levels and Symmetry," on page 3.
- Added Table 6, "CLK± Output Phase Noise (Typical)," on page 4.

CONTACT INFORMATION

Silicon Laboratories Inc.

4635 Boston Lane
Austin, TX 78735
Tel: 1+(512) 416-8500
Fax: 1+(512) 416-9669
Toll Free: 1+(877) 444-3032
Email: VCXOinfo@silabs.com
Internet: www.silabs.com

The information in this document is believed to be accurate in all respects at the time of publication but is subject to change without notice. Silicon Laboratories assumes no responsibility for errors and omissions, and disclaims responsibility for any consequences resulting from the use of information included herein. Additionally, Silicon Laboratories assumes no responsibility for the functioning of undescribed features or parameters. Silicon Laboratories reserves the right to make changes without further notice. Silicon Laboratories makes no warranty, representation or guarantee regarding the suitability of its products for any particular purpose, nor does Silicon Laboratories assume any liability arising out of the application or use of any product or circuit, and specifically disclaims any and all liability, including without limitation consequential or incidental damages. Silicon Laboratories products are not designed, intended, or authorized for use in applications intended to support or sustain life, or for any other application in which the failure of the Silicon Laboratories product could create a situation where personal injury or death may occur. Should Buyer purchase or use Silicon Laboratories products for any such unintended or unauthorized application, Buyer shall indemnify and hold Silicon Laboratories harmless against all claims and damages.

Silicon Laboratories, Silicon Labs, and DSPLL are trademarks of Silicon Laboratories Inc.
Other products or brandnames mentioned herein are trademarks or registered trademarks of their respective holders.