

# Battery Backup IC

## BD4201FV

BD4201FV is a battery backup IC. Switch that detect battery voltage and switch into back up power supply and 3-channel regulator are incorporated into a single chip.

Current consumption is 15 $\mu$ A (Max.). This IC is perfect for portable appliances.

### ●Applications

Portable video, Digital camera

### ●Features

- 1) Low quiescent current
  - Normal operation < 15.0 $\mu$ A Max.
  - Backup mode < 2.1 $\mu$ A Max.
- 2) 3 high accurate voltage regulators
- 3) Low dropout voltage, and high accurate voltage detectors (CS,  $\overline{\text{RESET}}$ )
- 4) Control circuit; Backup
- 5) Special sequence;
  - For shifting to the backup mode. It need to make main battery over +Vdet1 once.

### ●External dimensions (Unit : mm)

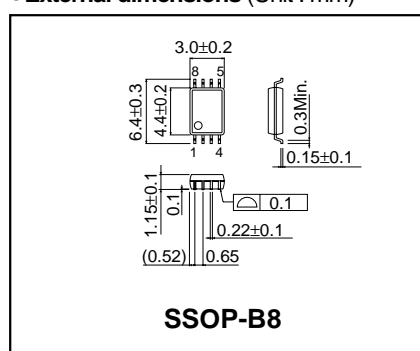

### ●Absolute maximum ratings (Ta=25°C)

Parameter	Symbol	Limits	Unit
Main power supply input Voltage	Vin	15	V
Back up power supply input Voltage	Vbat	15	V
CS output Voltage	Vcs	15	V
$\overline{\text{RESRT}}$ output Voltage	VRES	15	V
Power dissipation	Pd	350 *	mW
Operating temperature	Topr	-30 to +85	°C
Storage temperature	Tstg	-40 to +125	°C

\*70mm×70mm×1.6mm Glass fiber basis subtract 3.5mW /°C when over 25°C

### ●Commendable operating status (Ta=25°C)

Parameter	Symbol	Min.	Typ.	Max.	Unit
Power supply range	Vin	2.0	-	15.0	V
Backup power supply range	Vbat	2.0	-	15.0	V
Load current range1	Iro	0	-	20.0	mA
Load current range2	Iout	0	-	60.0	mA
Load current range3	Ich	0	-	20.0	mA

Regulators

●Block diagram

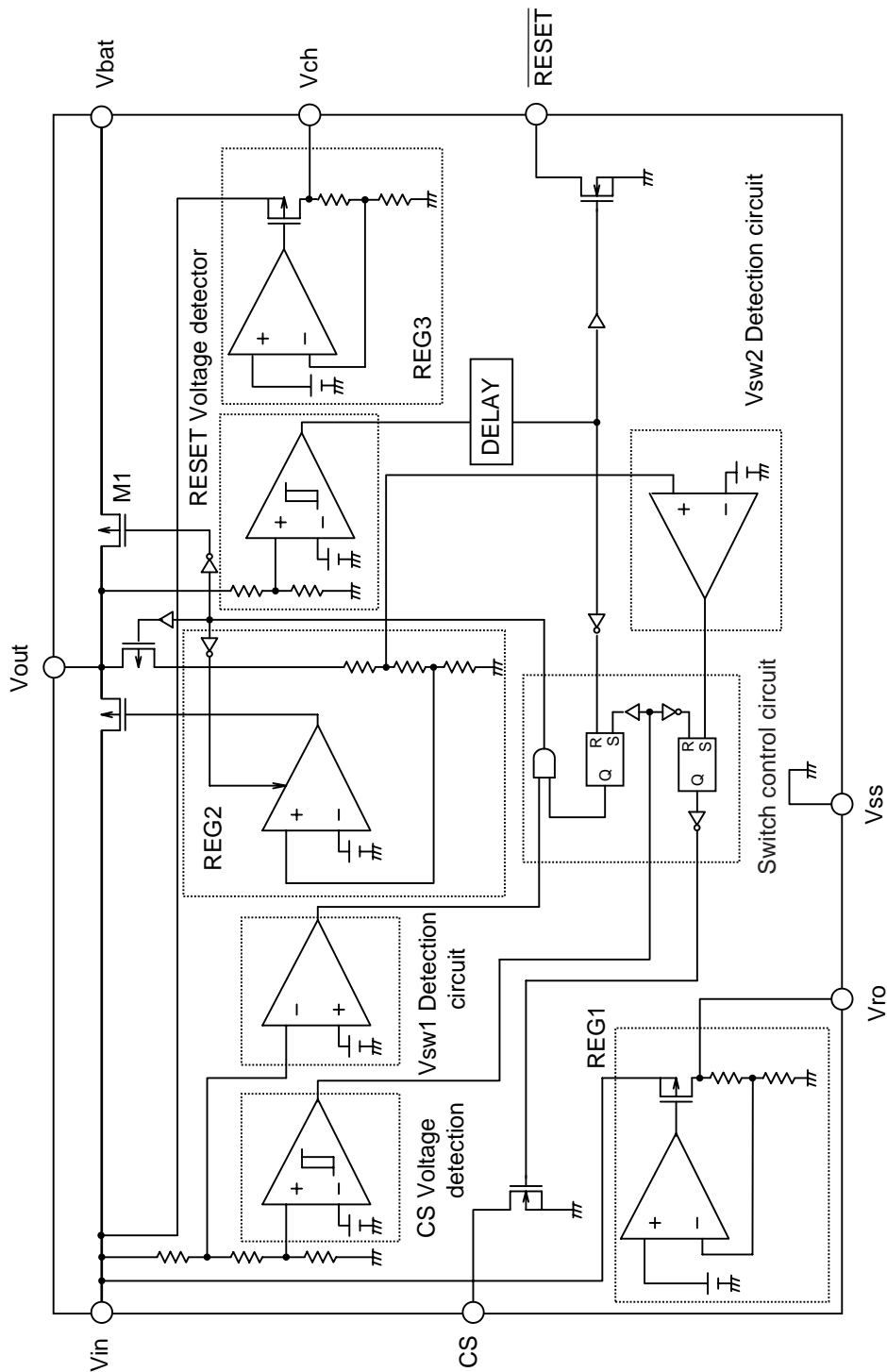

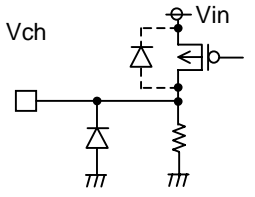
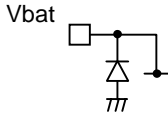
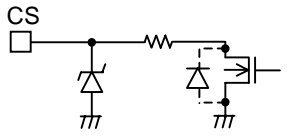
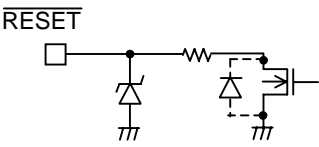
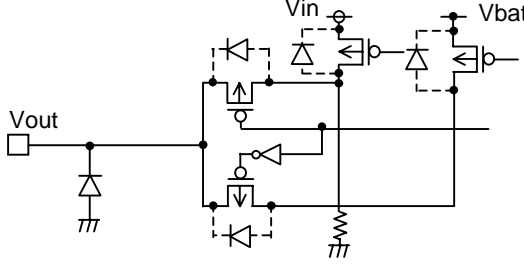
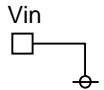
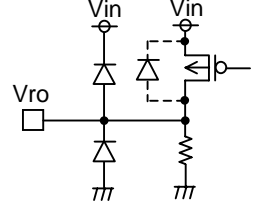

Fig. 1

Regulators

●Circuit around pin

Pin No.	Pin Name	Function	Pin No.	Pin Name	Function
①	Vss	Ground Pin	②	Vch	Regulator 3 output Pin
					
③	Vbat	Back up power supply input Pin	④	CS	CS voltage detector output Pin
					
⑤	$\overline{\text{RESET}}$	$\overline{\text{RESET}}$ voltage detector output Pin	⑥	Vout	Regulator2 output Pin
					
⑦	Vin	Main power supply input Pin	⑧	Vro	Regulator1 output Pin
					

## Regulators

## ●Electrical characteristics (Unless otherwise specified Vin=6V, Ta=25°C)

Parameter	Symbol	Min.	Typ.	Max.	Units	Conditions
[General spec]						
Main circuit current1	Iin1	–	10	15	μA	Vin=3.6V No load
Backup circuit current1	Ibat1	–	0.0	0.5	μA	Vin=3.6V Vbat=3V No load
Backup circuit current2	Ibat2	–	1.5	2.1	μA	Vin : Open Vbat=3V No load
[Regulator1]						
Output voltage 1	Vro	2.93	3.00	3.07	V	Vin=7.2V, Iro=3mA
Dropout voltage 1	Vdif1	–	0.1	0.35	V	Iro=3mA
Load regulation 1	ΔVlo1	–	30	100	mV	Vin=7.2V, Iro=100μA~20mA
Linc regulation 1	ΔVli1	–	50	100	mV	Vin=4~10V, Iro=3mA
[Regulator2]						
Output voltage 2	Vout	2.93	3.00	3.07	V	Vin=7.2V, Iout=23mA
Dropout voltage 2	Vdif2	–	0.25	0.35	V	Iout=23mA
Load regulation 2	ΔVlo2	–	30	110	mV	Vin=7.2V, Iout=100μA~60mA
Linc regulation 2	ΔVli2	–	60	110	mV	Vin=4~10V, Iout=23mA
[Regulator3]						
Output voltage 3	Vch	3.32	3.30	3.38	V	Vin=7.2V, Ich=3mA
Dropout voltage 3	Vdif3	–	0.1	0.35	V	Ich=3mA
Load regulation 3	ΔVlo3	–	30	110	mV	Vin=7.2, Ich=100μA~20mA
Linc regulation 3	ΔVli3	–	50	110	mV	Vin=4~10V, Ich=3mA
[Voltage detect block]						
CS detect voltage	–Vdet1	3.235	3.300	3.365	V	Vin voltage detection
CS release voltage	+Vdet1	3.320	3.400	3.480	V	
RESET detect voltage	–Vdet2	2.156	2.200	2.244	V	Vout voltage detection
RESET release voltage	+Vdet2	2.232	2.312	2.391	V	
RESET release delay time	+Tdet2	200	300		μS	
Low operating voltage	Vopr	2.0	–	–	V	Vin or Vbat
CS sink current	Icss	250	500	–	μA	Vcs=0.5V, Vin=Vbat=2.0V
CS leak current	Icst	–	–	0.1	μA	Vcs=15V, Vin=15V
RESET sink current	Ires	150	300	–	μA	Vreset=0.5V, Vin=Vbat=2.0V
RESET leak current	Irel	–	–	0.1	μA	Vreset=15V, Vin=15V
[Switch control block]						
Switch voltage	Vsw1	2.822	2.89	2.958	V	Vbat=2.8V
CS no output voltage	Vsw2	2.79	2.85	2.91	V	Vbat=3V
Vbat switch leak current	Ilek	–	–	1	μA	Vin=3.6V, Vbat=0V
Vbat switch resistor	Rsw	–	30	60	Ω	Vin=OPEN, Vbat=3V, Iout=10~500μA

© This product is not designed for protection against radioactive rays.

Regulators

●Measurement circuit

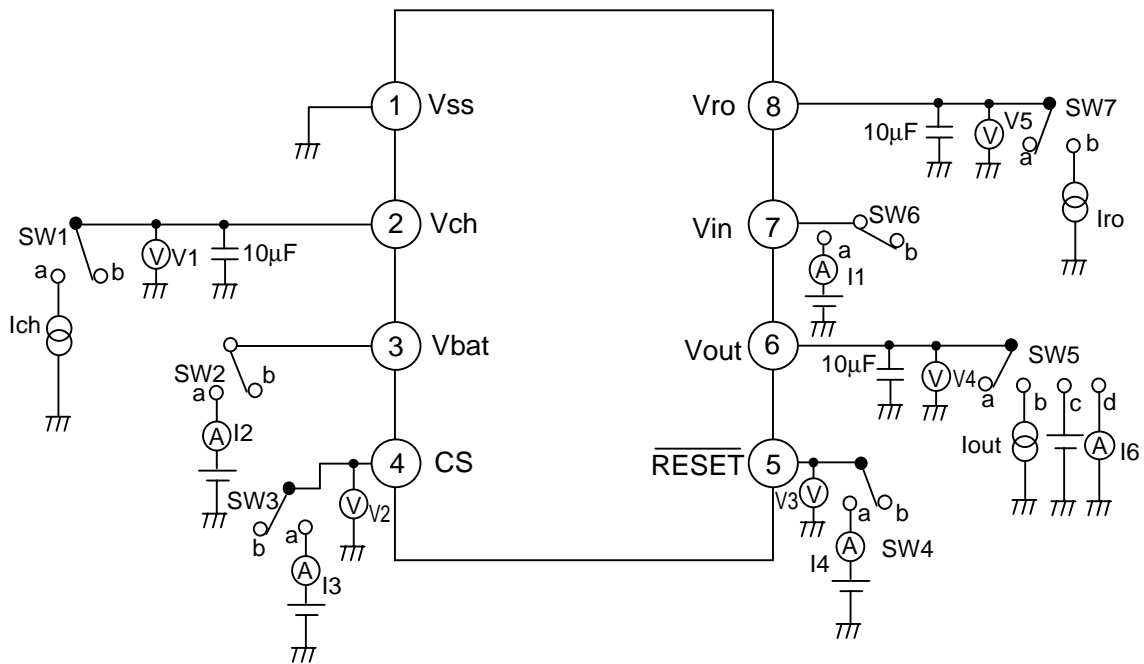

Fig.2

●Application circuit

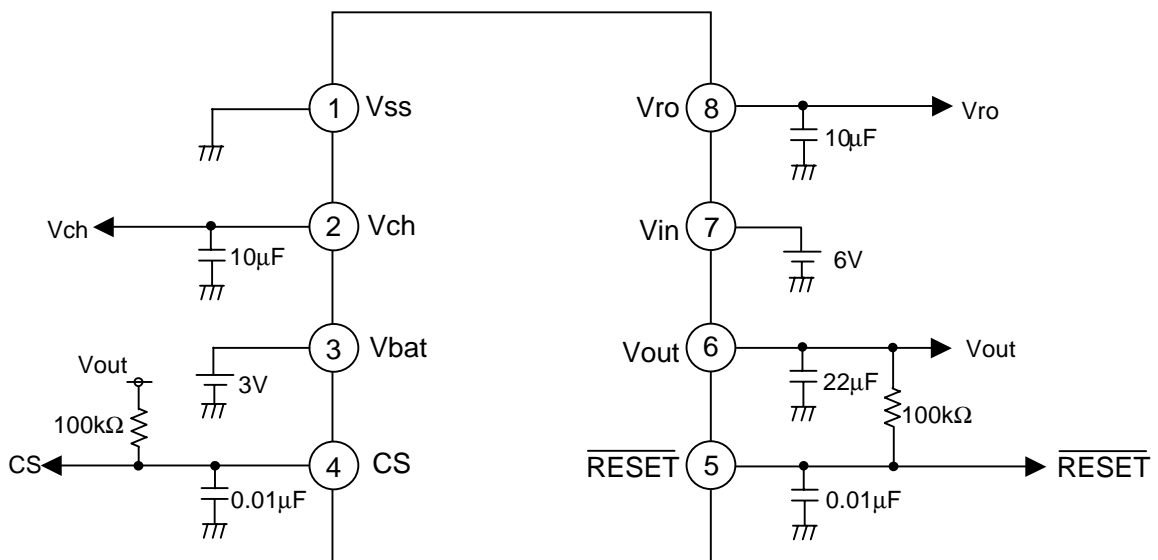
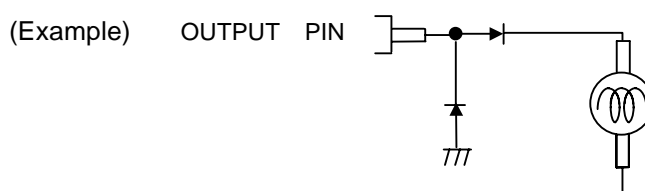

Fig.3

## Regulators

### ●Note for use

1. The application circuit is recommended for use. Make sure to confirm the adequacy of the characteristics. When using the circuit with changes to the external circuit constants, make sure to leave an adequate margin for external components including static and transitional characteristics as well as dispersion of the IC.
2. Operation supply voltage range  
The circuit functionality is guaranteed within the operation of ambient temperature range, as long as it is within the operation supply voltage range. The standard of electrical characteristic values cannot be guaranteed at other voltages in the operating range, however, the variation will be small.
3. The regulator output circuit of this IC does not include protect circuit for the unusual situations such as over voltage current protection, short detect circuit and thermal shut-down circuit.  
Therefore, this IC might be broken down when it is loaded exceeding the package power, or when it is shorted.  
To design application circuit, please deal it with enough consideration.
4. Oscillation stopper of output and bypass capacitor  
Please put into capacitor to stop oscillation between output pin and GND.  
It has a possibility of oscillation if capacitance is changed due to temperature range, and it recommends to use small tantalum electrolytic capacitor of equivalent serial resistor (ESR).  
If extremely big capacitor is used, it may have a case to occur oscillation of low frequency.  
Please confirm this point. And it recommend to put into bypass capacitor into the nearest position between input pin and GND.
5. For the grounding shown in the application circuit, wire every ground to GND terminal in a short pattern arrangement to avoid electrical disturbance.
6. This product is produced with strict quality control, but might be destroyed in using beyond absolute maximum ratings is considered. Open IC destroyed a failure mode cannot be defined (I like short mode, or open mode).  
Therefore, physical security countermeasure, like fuse, is to be given when a specific mode to be beyond absolute maximum ratings is considered.
7. Mal-function may happen when the device is used in the strong electromagnetic field.
8. Recommended to put DIODE for protection purpose in case of output pin connected with large load of impedance or reserve current occurred at initial and output off.



9. This IC is monolithic IC which (as shown in Figure-4) has P+ isolation in the P substrate and between the various pins. A P-N junction is formed from this P layer and N layer of each pin. For example, the relation between each potentials is as follows;  
(When  $GND > \text{pinB}$  and  $GND > \text{pinA}$ , the P-N junction operates as parasitic diode.)  
(When  $\text{pinB} > GND > \text{pinA}$ , the P-N junction operates as parasitic transistor.)  
Parasitic diodes can occur inevitably in the structure of the IC. The operation of parasitic diodes can result in mutual interference among circuits as well as operation faults and physical damage.  
Accordingly, Please do not use methods by which parasitic diode operate, such as applying a voltage that is lower than the GND (P substrate) voltage to an input pin.

Regulators

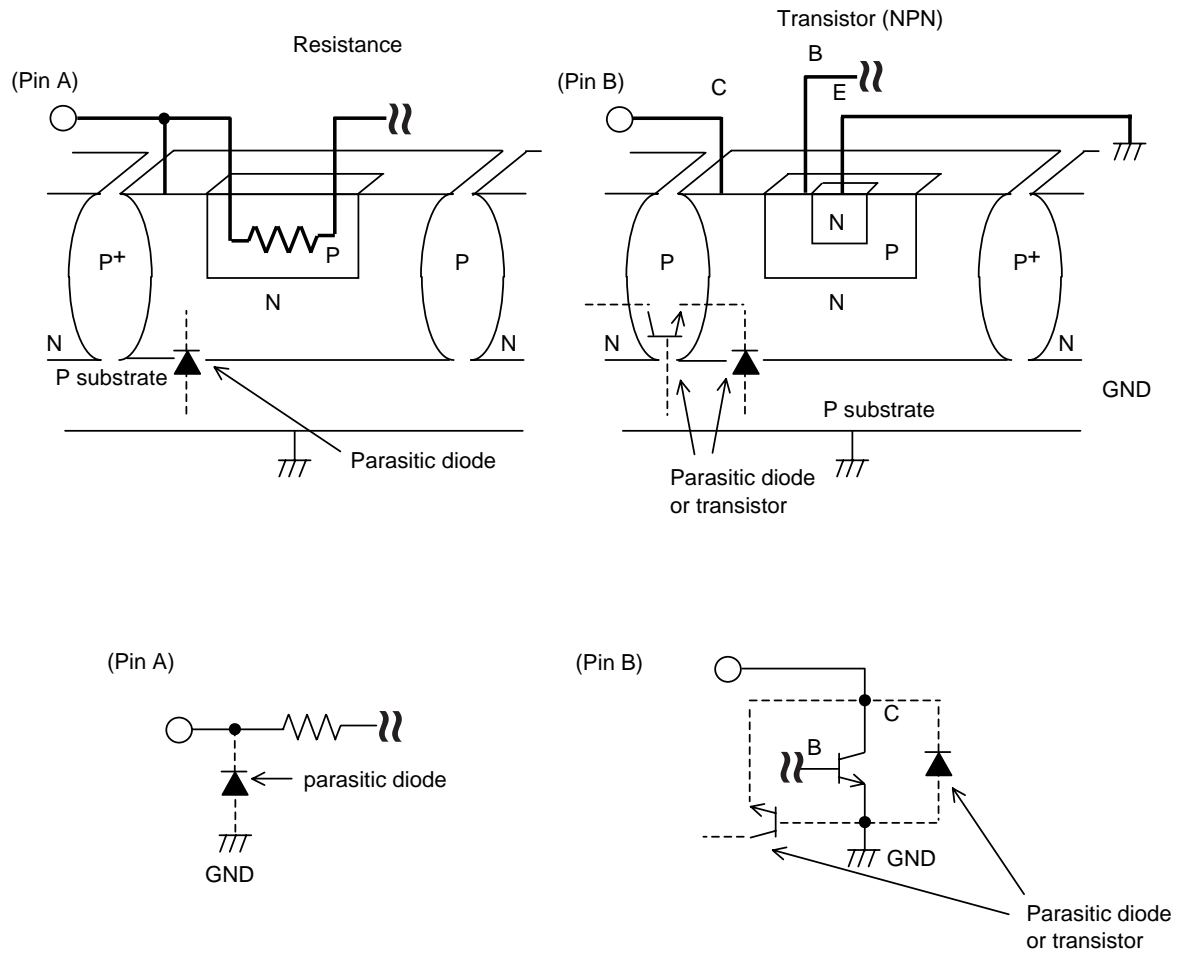

Fig.4 Simplified structure of IC

●Pin layout

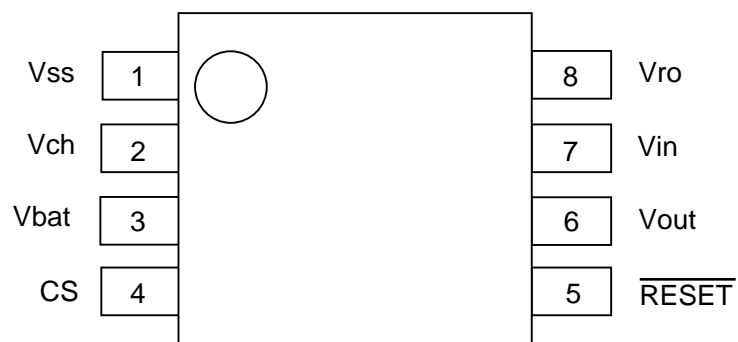

Fig. 5

## Regulators

## ●Electrical characteristic curves

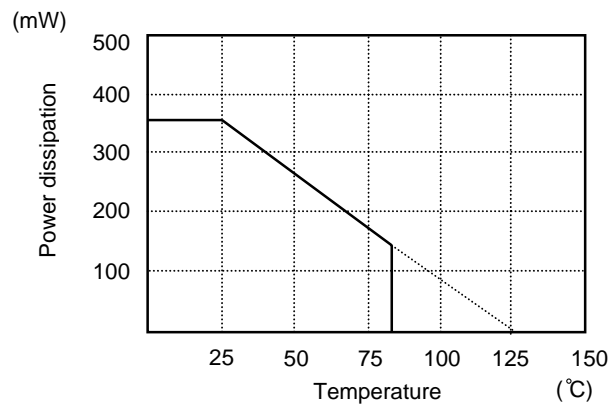

Fig.6 Power dissipation curve



### Notes

- No technical content pages of this document may be reproduced in any form or transmitted by any means without prior permission of ROHM CO.,LTD.
- The contents described herein are subject to change without notice. The specifications for the product described in this document are for reference only. Upon actual use, therefore, please request that specifications to be separately delivered.
- Application circuit diagrams and circuit constants contained herein are shown as examples of standard use and operation. Please pay careful attention to the peripheral conditions when designing circuits and deciding upon circuit constants in the set.
- Any data, including, but not limited to application circuit diagrams information, described herein are intended only as illustrations of such devices and not as the specifications for such devices. ROHM CO.,LTD. disclaims any warranty that any use of such devices shall be free from infringement of any third party's intellectual property rights or other proprietary rights, and further, assumes no liability of whatsoever nature in the event of any such infringement, or arising from or connected with or related to the use of such devices.
- Upon the sale of any such devices, other than for buyer's right to use such devices itself, resell or otherwise dispose of the same, no express or implied right or license to practice or commercially exploit any intellectual property rights or other proprietary rights owned or controlled by
- ROHM CO., LTD. is granted to any such buyer.
- Products listed in this document use silicon as a basic material.  
Products listed in this document are no antiradiation design.

The products listed in this document are designed to be used with ordinary electronic equipment or devices (such as audio visual equipment, office-automation equipment, communications devices, electrical appliances and electronic toys).

Should you intend to use these products with equipment or devices which require an extremely high level of reliability and the malfunction of which would directly endanger human life (such as medical instruments, transportation equipment, aerospace machinery, nuclear-reactor controllers, fuel controllers and other safety devices), please be sure to consult with our sales representative in advance.

#### About Export Control Order in Japan

Products described herein are the objects of controlled goods in Annex 1 (Item 16) of Export Trade Control Order in Japan.

In case of export from Japan, please confirm if it applies to "objective" criteria or an "informed" (by MITI clause) on the basis of "catch all controls for Non-Proliferation of Weapons of Mass Destruction.