

LNA4905L

GaAs Infrared Light Emitting Diode

For optical control equipment

■ Features

- High output power, high-efficiency : (15 mW min.)
- Quick response, high speed modulation ($f_c=30$ MHz typ.)
- Transparent epoxy resin package

■ Absolute Maximum Ratings $T_a=25^\circ\text{C}$

Parameter	Symbol	Ratings	Unit
Power dissipation	P_D	190	mW
Forward current(DC)	I_F	100	mA
Pulse forward current *	I_{FP}	1	A
Reverse voltage(DC)	V_R	3	V
Operating ambient temperature	T_{opr}	-25 to +85	$^\circ\text{C}$
Storage temperature	T_{stg}	-30 to +100	$^\circ\text{C}$

Note) * : $f=100$ Hz, Duty cycle=0.1%

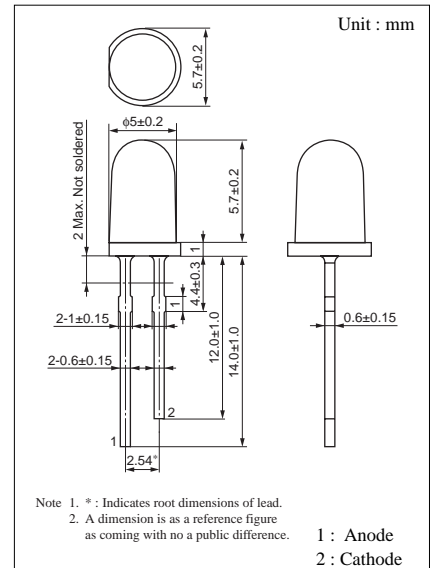

■ Electro-optical $T_a=25^\circ\text{C}\pm 3^\circ\text{C}$

Parameter	Symbol	Conditions	min	typ	max	Unit
Total power output	P_O	$I_F=50$ mA	15			mW
Peak emission wavelength	λ_p	$I_F=50$ mA		880		nm
Spectral half band width	$\Delta\lambda$	$I_F=50$ mA		50		nm
Forward voltage (DC)	V_F	$I_F=100$ mA		1.7	2.1	V
Reverse current (DC)	I_R	$V_F=3$ V			10	μA
Half-power angle	θ	The angle when the beam intensity is halved		15		deg

Note) 1. Cut-off frequency : 30 MHz

2. LED might radiate red light under large current drive.