



Am79C978A

PCnet™- Home Single-Chip 1/10 Mbps PCI Home Networking Controller

DISTINCTIVE CHARACTERISTICS

- Fully integrated 1 Mbps HomePNA Physical Layer (PHY) as defined by Home Phoneline Networking Alliance (HomePNA) specification 1.1
 - Optimized for home networking applications over ordinary copper telephone wire
 - In-band control features
- Adjustable power and speed levels
- 32 bits of reserved in-band messaging piggybacked on Ethernet packet
 - Register programmable features
- Power control
- Performance registers
- Speed control
- Major frame timing parameters programmable: ISBI, AID ISBI, pulse width, inter-symbol time
- Fully integrated 10 Mbps PHY interface
 - Comprehensive Auto-Negotiation implementation
 - Full-duplex capability
 - Optimized for 10BASE-T applications
- Integrated Fast Ethernet controller for the Peripheral Component Interconnect (PCI) bus
 - 32-bit glueless PCI host interface
 - Supports PCI clock frequency from DC to 33 MHz independent of network clock
 - Supports network operation with PCI clock from 15 MHz to 33 MHz
 - High performance bus mastering architecture with integrated Direct Memory Access (DMA) Buffer Management Unit for low CPU and bus utilization
 - PCI draft specification revision 2.2 compliant
 - Supports PCI Subsystem/Subvendor ID/ Vendor ID programming through the EEPROM interface
 - Supports both PCI 5.0-V and 3.3-V signaling environments
 - Plug and Play compatible
 - Supports an unlimited PCI burst length
- Big endian and little endian byte alignments supported
- Implements optional PCI power management event (PME) pin
- Dual-speed CSMA/CD (10 Mbps and 100 Mbps) Media Access Controller (MAC) compliant with IEEE/ANSI 802.3 Ethernet standard
- Compliant with HomePNA specification 1.1
- Media Independent Interface (MII) for connecting external 10/100 Mbps transceivers
 - IEEE 802.3u compliant MII
 - Intelligent Auto-Poll™ external PHY status monitor and interrupt
 - Supports both auto-negotiable and non-auto-negotiable external PHYs
 - Supports 10BASE-T, 100BASE-TX/FX, 100BASE-T4, and 100BASE-2 IEEE 802.3 compliant MII PHYs at full-duplex or half-duplex
- Full-duplex operation supported on the MII port with independent Transmit (TX) and Receive (RX) channels
- Supports PC98/PC99 and Net PC specifications
 - Implements full OnNow features including pattern matching and link status wake-up events
 - Implements Magic Packet™ mode
 - Magic Packet mode and the physical address loaded from EEPROM at power up without requiring PCI clock
 - Supports PCI Bus Power Management Interface specification revision 1.1
 - Supports Advanced Configuration and Power Interface (ACPI) specification version 1.0
 - Supports Network Device Class Power Management specification version 1.0a
- Independent internal TX and RX FIFOs
 - Programmable FIFO watermarks for both TX and RX operations

- RX frame queuing for high latency PCI bus host operation
- Programmable allocation of buffer space between RX and TX queues
- Extensive programmable internal/external loopback capabilities
- EEPROM interface supports jumperless design and provides through-chip programming
 - Supports full programmability of half-/full-duplex operation through EEPROM mapping
 - Programmable PHY reset output pin capable of resetting external PHY without the need for buffering
- Extensive programmable LED status support
- Look-Ahead Packet Processing (LAPP) data handling technique reduces system overhead
- by allowing protocol analysis to begin before the end of a receive frame
- Includes Programmable Inter Packet Gap (IPG) to address less network aggressive MAC controllers
- Offers the Modified Back-Off algorithm to address the *Ethernet Capture Effect*
- IEEE 1149.1-compliant JTAG Boundary Scan test access port interface and NAND tree test mode for board-level production connectivity test
- Software compatible with AMD's PCnet™ Family and LANCE/C-LANCE register and descriptor architecture
- Very low power consumption
- +3.3 V power supply along with 5 V tolerant I/Os enable broad system compatibility
- Available in 144-pin TQFP and 160-pin PQFP packages

GENERAL DESCRIPTION

The Am79C978A controller is the first in a series of home networking products from AMD. The Am79C978A controller is fabricated in an advanced low power 3.3 V CMOS process to provide low operating current for power sensitive applications.

The Am79C978A controller contains an Ethernet Controller based on the Am79C971 Fast Ethernet controller, a physical layer device for supporting the 802.3 standard for 10BASE-T, and a physical layer device for data networking at speeds up to 1 Mbps over ordinary residential telephone wiring.

The integrated PCI Ethernet controller is a highly integrated 32-bit full-duplex, 10/100 Mbps Ethernet controller solution designed to address high-performance system application requirements. It is a flexible bus-mastering device that can be used in any application, including network ready PCs. The bus master architecture provides high data throughput and low CPU and system bus utilization.

The integrated Ethernet transceiver is a physical layer device supporting the IEEE 802.3 standards for 10BASE-T. It provides all of the PHY layer functions required to support 10 Mbps data transfer speeds.

The integrated HomePNA transceiver is a physical layer device that enables data networking at speeds up to 1 Mbps over common residential phone wiring regardless of topology and without disrupting telephone (POTS) service.

The 32-bit multiplexed bus interface unit provides a direct interface to the PCI local bus, simplifying the design of an Ethernet or home network node in a PC system. The device has built-in support for both little and big endian byte alignment. The integrated home

networking controller's advanced CMOS design allows the bus interface to be connected to either a +5.0 V or a +3.3 V signaling environment. A compliant IEEE 1149.1 JTAG test interface for board level testing is also provided, as well as a NAND tree test structure for those systems that do not support the JTAG interface.

The integrated Am79C978A home networking controller is also compliant with the PC98, PC99, and Net PC specifications. It includes the full implementation of the Microsoft OnNow and ACPI specifications, which are backward compatible with Magic Packet technology, and is compliant with the PCI Bus Power Management Interface specification by supporting the four power management states (D0, D1, D2, and D3), the optional $\overline{\text{PME}}$ pin, and the necessary configuration and data registers.

The integrated Am79C978A home networking controller is a complete Ethernet or home network node integrated into a single VLSI device. It contains a bus interface unit, a Direct Memory Access (DMA) Buffer Management Unit, an ISO/IEC 88023 (IEEE 802.3) compliant Media Access Controller (MAC), a Transmit FIFO and a large Receive FIFO, and an IEEE 802.3u compliant MII. Both IEEE 802.3 compliant full-duplex and half-duplex operations are supported on the MII interface. 10/100 Mbps operation is supported through the MII interface.

The integrated Am79C978A home networking controller is register compatible with the LANCE (Am7990) and C-LANCE (Am79C90) Ethernet controllers and all Ethernet controllers in the PCnet Family (except ILACC™ (Am79C900)), including PCnet-ISA (Am79C960), PCnet-ISA+ (Am79C961), PCnet-ISA II (Am79C961A), PCnet-32 (Am79C965A), PCnet-PCI (Am79C970), PCnet-PCI II (Am79C970A), PCnet-

FAST (Am79C971), and *PCnet-FAST+* (Am79C972). The Buffer Management Unit supports the LANCE and PCnet descriptor software models.

The integrated Am79C978A controller supports auto-configuration in the PCI configuration space. Additional integrated controller configuration parameters, including the unique IEEE physical address, can be read from an

external non-volatile memory (EEPROM) immediately following system reset.

In addition, the Am79C978A controller provides programmable on-chip LED drivers for transmit, receive, collision, link integrity, Magic Packet status, speed, activity, power output, address match, full-duplex, or 100 Mbps status.

BLOCK DIAGRAM

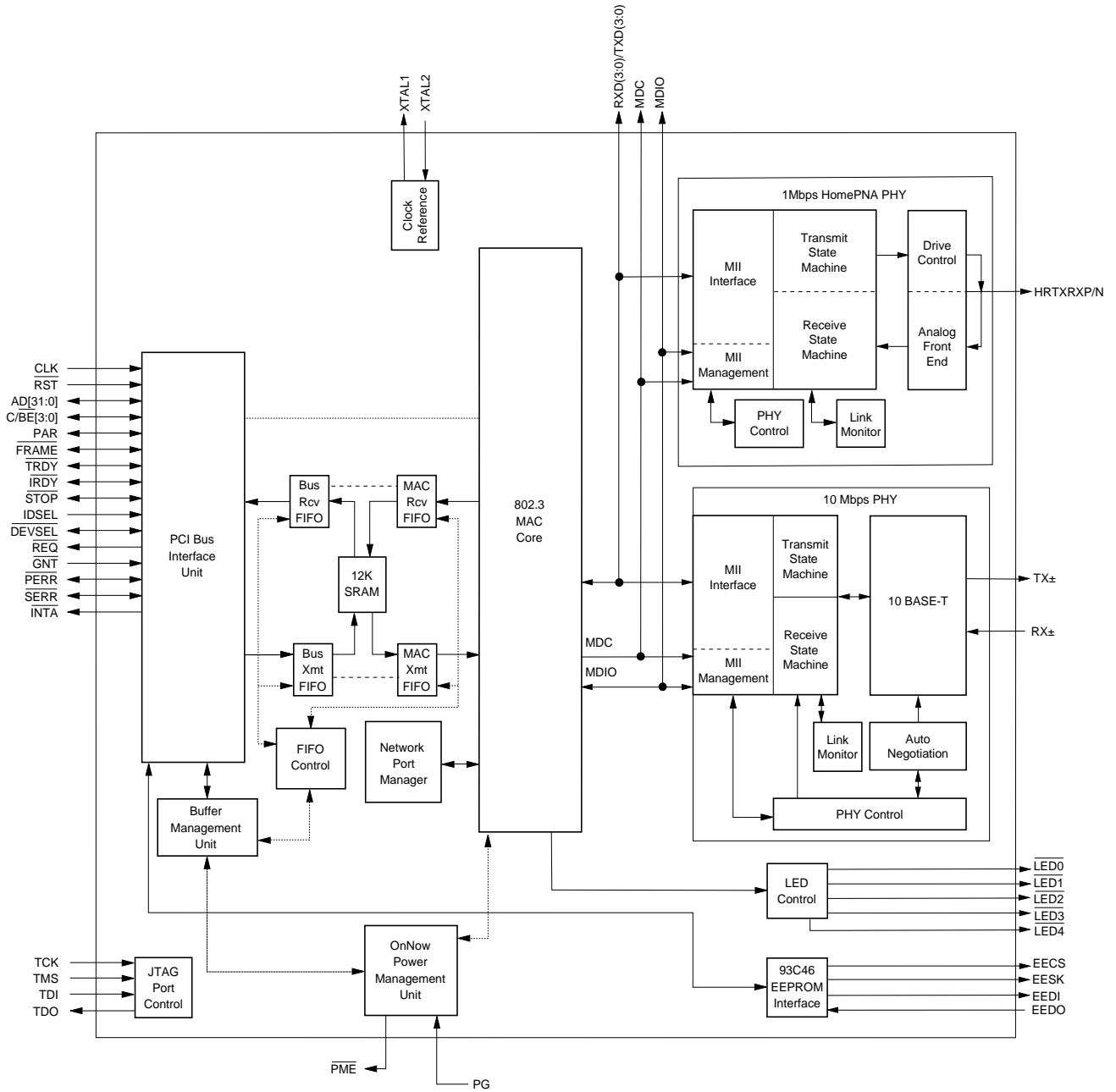

22399A-1

TABLE OF CONTENTS

AM79C978A	1
DISTINCTIVE CHARACTERISTICS	1
GENERAL DESCRIPTION	2
BLOCK DIAGRAM	4
TABLE OF CONTENTS	5
RELATED AMD PRODUCTS	10
CONNECTION DIAGRAM (144 TQFP)	11
CONNECTION DIAGRAM (160 PQFP)	12
PIN DESIGNATIONS (PQL144)	13
Listed By Pin Number	13
PIN DESIGNATIONS (PQR160)	14
Listed By Pin Number	14
PIN DESIGNATIONS (PQL144)	15
Listed By Group	15
PIN DESIGNATIONS (PQR160)	17
Listed By Group	17
PIN DESIGNATIONS	19
Listed By Driver Type	19
ORDERING INFORMATION	20
Standard Products	20
PIN DESCRIPTIONS	21
PCI Interface	21
Magic Packet Interface	23
Board Interface	24
EEPROM Interface	24
MII Interface	25
IEEE 1149.1 (1990) Test Access Port Interface	26
Ethernet Network Interfaces	26
HomePNA PHY Network Interface	27
Clock Interface	27
External Crystal Characteristics	27
Power Supply	27
BASIC FUNCTIONS	29
System Bus Interface	29
Software Interface	29
Network Interfaces	29
Media Independent Interface	29
10BASE-T PHY	32
PCI and JTAG Configuration Information	32
Slave Bus Interface Unit	32
Slave Configuration Transfers	32
Slave I/O Transfers	33
Expansion ROM Transfers	35
Slave Cycle Termination	35
Parity Error Response	37
Master Bus Interface Unit	39
Buffer Management Unit	56
Software Interrupt Timer	62
10/100 Media Access Controller	62
Transmit Operation	65
Receive Operation	67
Loopback Operation	70
PHY/MAC Interface	71
10BASE-T Physical Layer	71
Auto-Negotiation	72
DETAILED FUNCTIONS	74

1 Mbps HomePNA PHY74
HomePNA PHY Medium Interface74
Management Interfaces79
EEPROM Interface83
LED Support84
Power Savings Mode86
Magic Packet Mode88
IEEE 1149.1 (1990) Test Access Port Interface90
NAND Tree Testing91
Reset93
Software Access94
USER ACCESSIBLE REGISTERS98
PCI Configuration Registers99
RAP Register108
Control and Status Registers (CSRs)109
Bus Configuration Registers (BCRs)143
10BASE-T PHY Management Registers (TBRs)177
1 Mbps HomePNA PHY Internal Registers187
Initialization Block195
Receive Descriptors197
Transmit Descriptors200
REGISTER SUMMARY204
PCI Configuration Registers204
Control and Status Registers205
Bus Configuration Registers209
10BASE-T PHY Management Registers210
1 Mbps HomePNA PHY Management Registers211
REGISTER PROGRAMMING SUMMARY212
Am79C978A Programmable Registers212
ABSOLUTE MAXIMUM RATINGS217
OPERATING RANGES217
Commercial (C) Devices217
DC CHARACTERISTICS OVER COMMERCIAL OPERATING RANGES UNLESS OTHERWISE SPECIFIED217
SWITCHING CHARACTERISTICS: BUS INTERFACE219
10BASE-T Mode221
Power Supply Current221
External Clock222
PMD Interface222
10BASE-T223
SWITCHING CHARACTERISTICS: MEDIA INDEPENDENT INTERFACE224
SWITCHING WAVEFORMS225
Key to Switching Waveforms225
SWITCHING TEST CIRCUITS225
SWITCHING WAVEFORMS: SYSTEM BUS INTERFACE226
SWITCHING WAVEFORMS: MEDIA INDEPENDENT INTERFACE230
PHYSICAL DIMENSIONS*232
PQL144232
Thin Quad Flat Pack (measured in millimeters)232
PQR160233
Plastic Quad Flat Pack (measured in millimeters)233
APPENDIX A — ALTERNATIVE METHOD FOR INITIALIZATION	A-1
APPENDIX B — LOOK AHEAD PACKET PROCESSING (LAPP) CONCEPT	B-1
Introduction	B-1
Outline of LAPP Flow	B-1
INDEX	Index-1

LIST OF FIGURES

Figure 1. Media Independent Interface	30
Figure 2. Frame Format at the MII Interface Connection	31
Figure 3. Slave Configuration Read	34
Figure 4. Slave Configuration Write	34
Figure 5. Slave Read Using I/O Command	34
Figure 6. Slave Write Using Memory Command	35
Figure 7. Expansion ROM Read	36
Figure 8. Disconnect of Slave Cycle When Busy	37
Figure 9. Disconnect of Slave Burst Transfer - No Host Wait States	37
Figure 10. Disconnect of Slave Burst Transfer - Host Inserts Wait States	37
Figure 11. Address Parity Error Response	38
Figure 12. Slave Cycle Data Parity Error Response	38
Figure 13. Bus Acquisition	39
Figure 14. Non-Burst Read Transfer	40
Figure 15. Burst Read Transfer (EXTREQ = 0, MEMCMD = 0)	41
Figure 16. Non-Burst Write Transfer	42
Figure 17. Burst Write Transfer (EXTREQ = 1)	43
Figure 18. Disconnect With Data Transfer	44
Figure 19. Disconnect Without Data Transfer	45
Figure 20. Target Abort	46
Figure 21. Preemption During Non-Burst Transaction	47
Figure 22. Preemption During Burst Transaction	47
Figure 23. Master Abort	48
Figure 24. Master Cycle Data Parity Error Response	48
Figure 25. Initialization Block Read In Non-Burst Mode	50
Figure 26. Initialization Block Read In Burst Mode	50
Figure 27. Descriptor Ring Read In Non-Burst Mode	52
Figure 28. Descriptor Ring Read In Burst Mode	52
Figure 29. Descriptor Ring Write In Non-Burst Mode	53
Figure 30. Descriptor Ring Write In Burst Mode	53
Figure 31. FIFO Burst Write at Start of Unaligned Buffer	55
Figure 32. FIFO Burst Write at End of Unaligned Buffer	55
Figure 33. 16-Bit Software Model	58
Figure 34. 32-Bit Software Model	59
Figure 35. ISO 8802-3 (IEEE/ANSI 802.3) Data Frame	66
Figure 36. IEEE 802.3 Frame and Length Field Transmission Order	70
Figure 37. 10BASE-T Transmit and Receive Data Paths	72
Figure 38. HomePNA PHY Framing	75
Figure 39. AID Symbol Transmit Timing	76
Figure 40. AID Symbol Receive Timing	76
Figure 41. Transmit Data Symbol Timing	78
Figure 42. Receive Symbol Timing	78
Figure 43. RLL 25 Coding Tree	79
Figure 44. Block Diagram No SRAM Configuration	82
Figure 45. Block Diagram Low Latency Receive Configuration	82
Figure 46. LED Control Logic	86
Figure 47. OnNow Functional Diagram	87
Figure 48. Pattern Match RAM	89
Figure 49. NAND Tree Circuitry (160 PQFP)	91
Figure 50. NAND Tree Waveform	93
Figure 51. Address Match Logic	197
Figure 52. Clock Timing	222
Figure 53. PMD Interface Timing (PECL)	222
Figure 54. 10 Mbps Transmit (TX±) Timing Diagram	223
Figure 55. 10 Mbps Receive (RX±) Timing Diagram	223
Figure 56. Normal and Tri-State Outputs	225
Figure 57. CLK Waveform for 5 V Signaling	226

Figure 58. CLK Waveform for 3.3 V Signaling226
 Figure 59. Input Setup and Hold Timing226
 Figure 60. Output Valid Delay Timing227
 Figure 61. Output Tri-State Delay Timing227
 Figure 62. EEPROM Read Functional Timing227
 Figure 63. Automatic PREAD EEPROM Timing228
 Figure 64. JTAG (IEEE 1149.1) TCK Waveform for 5 V Signaling228
 Figure 65. JTAG (IEEE 1149.1) Test Signal Timing229
 Figure 66. Transmit Timing230
 Figure 67. Receive Timing230
 Figure 68. MDC Waveform230
 Figure 69. Management Data Setup and Hold Timing231
 Figure 70. Management Data Output Valid Delay Timing231
 Figure B-1. LAPP TimelineB-4
 Figure B-2. LAPP 3 Buffer GroupingB-5
 Figure B-3. LAPP Timeline for Two-Interrupt MethodB-9
 Figure B-4. LAPP 3 Buffer Grouping for Two-interrupt MethodB-10

LIST OF TABLES

Table 1. Interrupt Flags22
 Table 2. External Clock/Crystal Select27
 Table 3. Crystal Characteristics27
 Table 4. PCI Device ID32
 Table 5. PCI Software Configuration32
 Table 6. Slave Commands32
 Table 7. Slave Configuration Transfers33
 Table 8. Master Commands39
 Table 9. Descriptor Read Sequence51
 Table 10. Descriptor Write Sequence54
 Table 11. Receive Address Match69
 Table 12. Auto-Negotiation Capabilities73
 Table 13. HomePNA PHY Pulse Parameters75
 Table 14. Access ID Symbol Pulse Positions and Encoding77
 Table 15. Blanking Interval Speed Settings78
 Table 16. Master Station Control Word Functions80
 Table 17. Slave Station Control Word Status Conditions80
 Table 18. MII Control Frame Format81
 Table 19. EEPROM Map85
 Table 20. LED Default Configuration86
 Table 21. IEEE 1149.1 Supported Instruction Summary90
 Table 22. BSR Mode Of Operation90
 Table 23. Device ID Register90
 Table 24. NAND Tree Pin Sequence (160 PQFP)92
 Table 25. NAND Tree Pin Sequence (144 TQFP)92
 Table 26. PCI Configuration Space Layout94
 Table 27. I/O Map in Word I/O Mode (DWIO = 0)96
 Table 28. Legal I/O Accesses in Word I/O Mode (DWIO = 0)96
 Table 29. I/O Map in DWord I/O Mode (DWIO = 1)97
 Table 30. Legal I/O Accesses in Double Word I/O Mode (DWIO =1)97
 Table 31. Loopback Configuration125
 Table 32. Software Styles133
 Table 33. Receive Watermark Programming136
 Table 34. Transmit Start Point Programming136
 Table 35. Transmit Watermark Programming137
 Table 36. BCR Registers144
 Table 37. ROMTNG Programming Values154
 Table 38. PHY Select Programming157

Table 39. EEDET Setting	159
Table 40. Interface Pin Assignment	159
Table 41. Software Styles	161
Table 42. SRAM_BND Programming	163
Table 43. EBCS Values	164
Table 44. CLK_FAC Values	165
Table 45. FMDC Values	168
Table 46. APDW Values	168
Table 47. Am79C978A 10BASE-T PHY Management Register Set	177
Table 48. TBR0: 10BASE-T PHY Control Register (Register 0)	178
Table 49. TBR1: 10BASE-T PHY Status Register (Register 1)	179
Table 50. TBR2: 10BASE-T PHY Identifier (Register 2)	180
Table 51. TBRM0BASE-T PHY Identifier (Register 3)	180
Table 52. TBR4: 10BASE-T Auto-Negotiation Advertisement Register (Register 4)	181
Table 53. TBR5: 10BASE-T Auto-Negotiation Link Partner Ability Register (Register 5) - Base Page Format	182
Table 54. TBR5: 10BASE-T Auto-Negotiation Link Partner Ability Register (Register 5) - Next Page Format	182
Table 55. TBR6: 10BASE-T Auto-Negotiation Expansion Register (Register 6)	183
Table 56. TBR7: 10BASE-T Auto-Negotiation Next Page Register (Register 7)	183
Table 57. TBR16: 10BASE-T INTERRUPT Status and Enable Register (Register 16)	184
Table 58. TBR17: 10BASE-T PHY Control/Status Register (Register 17)	185
Table 59. TBR19: 10BASE-T PHY Management Extension Register (Register 19)	186
Table 60. TBR24: 10BASE-T Summary Status Register (Register 24)	186
Table 61. HPR0: HomePNA PHY MII Control (Register 0)	187
Table 62. HPR1: HomePNA PHY MII Status (Register 1)	188
Table 63. HPR2 and HPR3: HomePNA PHY MII ID (Registers 2 and 3)	189
Table 64. HPR4-HPR7: HomePNA PHY Auto-Negotiation (Registers 4 - 7)	189
Table 65. HPR16: HomePNA PHY Control (Register 16)	190
Table 66. HPR18 and HPR19: HomePNA PHY TxCOMM (Registers 18 and 19)	191
Table 67. HPR20 and HPR21: HomePNA PHY RxCOMM (Registers 20 and 21)	191
Table 68. HPR22: HomePNA PHY AID (Register 22)	192
Table 69. HPR23: HomePNA PHY Noise Control (Register 23)	192
Table 70. HPR24: HomePNA PHY Noise Control 2 (Register 24)	192
Table 71. HPR25: HomePNA PHY Noise Statistics (Register 25)	193
Table 72. HPR26: HomePNA PHY Event Status (Register 26)	193
Table 73. HPR27: HomePNA PHY Event Status (Register 27)	194
Table 74. HPR8: HomePNA PHY ISBI Control (Register 28)	194
Table 75. HPR29: HomePNA PHY TX Control (Register 29)	194
Table 76. Initialization Block (SSIZE32 = 0)	195
Table 77. Initialization Block (SSIZE32 = 1)	195
Table 78. R/TLEN Decoding (SSIZE32 = 0)	196
Table 79. R/TLEN Decoding (SSIZE32 = 1)	196
Table 80. Receive Descriptor (SWSTYLE = 0)	197
Table 81. Receive Descriptor (SWSTYLE = 2)	197
Table 82. Receive Descriptor (SWSTYLE = 3)	197
Table 83. Transmit Descriptor (SWSTYLE = 0)	200
Table 84. Transmit Descriptor (SWSTYLE = 2)	200
Table 85. Transmit Descriptor (SWSTYLE = 3)	200
Table 86. PCI Configuration Registers	204
Table 87. 10BASE-T PHY Management Registers (TBRS)	210
Table 88. 1 Mbps HomePNA PHY Management Registers (HPRs)	211
Table 89. Control and Status Registers	212
Table 90. Bus Configuration Registers	214
Table A-1. Registers for Alternative Initialization Method (Note 1)	A-1

RELATED AMD PRODUCTS

Part No.	Description
Controllers	
Am79C90	CMOS Local Area Network Controller for Ethernet (C-LANCE)
Integrated Controllers	
Am79C930	PCnet™-Mobile Single Chip Wireless LAN Media Access Controller
Am79C940B	Media Access Controller for Ethernet (MACE™)
Am79C961A	PCnet-ISA II Full Duplex Single-Chip Ethernet Controller for ISA Bus
Am79C965A	PCnet-32 Single-Chip 32-Bit Ethernet Controller for 486 and VL Buses
Am79C970A	PCnet-PCI II Full Duplex Single-Chip Ethernet Controller for PCI Local Bus
Am79C971	PCnet-FAST Single-Chip Full-Duplex 10/100 Mbps Ethernet Controller for PCI Local Bus
Am79C972	PCnet-FAST+ Enhanced 10/100 Mbps PCI Ethernet Controller with OnNow Support
Manchester Encoder/Decoder	
Am7992B	Serial Interface Adapter (SIA)
Physical Layer Devices (Single-Port)	
Am7996	IEEE 802.3/Ethernet/Cheapernet Transceiver (TAP)
Am79761	Physical Layer 10-Bit Transceiver for Gigabit Ethernet (GigaPHY™-SD)
Am79C98	Twisted Pair Ethernet Transceiver (TPEX)
Am79C100	Twisted Pair Ethernet Transceiver Plus (TPEX+)
Am79C873	10/100 Mbps Ethernet Physical Layer Transceiver (NetPHY™-1)
Am79C901A	Single-chip 1/10 Mbps Home Networking PHY (HomePHY™)
Physical Layer Devices (Multi-Port)	
Am79C871	Quad Fast Ethernet Transceiver for 100BASE-X Repeaters (QFEXr™)
Am79C988B	Quad Integrated Ethernet Transceiver (QuIET™)
Am79C989	Quad Ethernet Switching Transceiver (QuEST™)
Integrated Repeater/Hub Devices	
Am79C981	Integrated Multiport Repeater Plus (IMR+)
Am79C982	Basic Integrated Multiport Repeater (bIMR)
Am79C983A	Integrated Multiport Repeater 2 (IMR2™)
Am79C984A	Enhanced Integrated Multiport Repeater (eIMR™)
Am79C985	Enhanced Integrated Multiport Repeater Plus (eIMR+™)
Am79C987	Hardware Implemented Management Information Base (HIMIB™)

CONNECTION DIAGRAM (PQL 144)

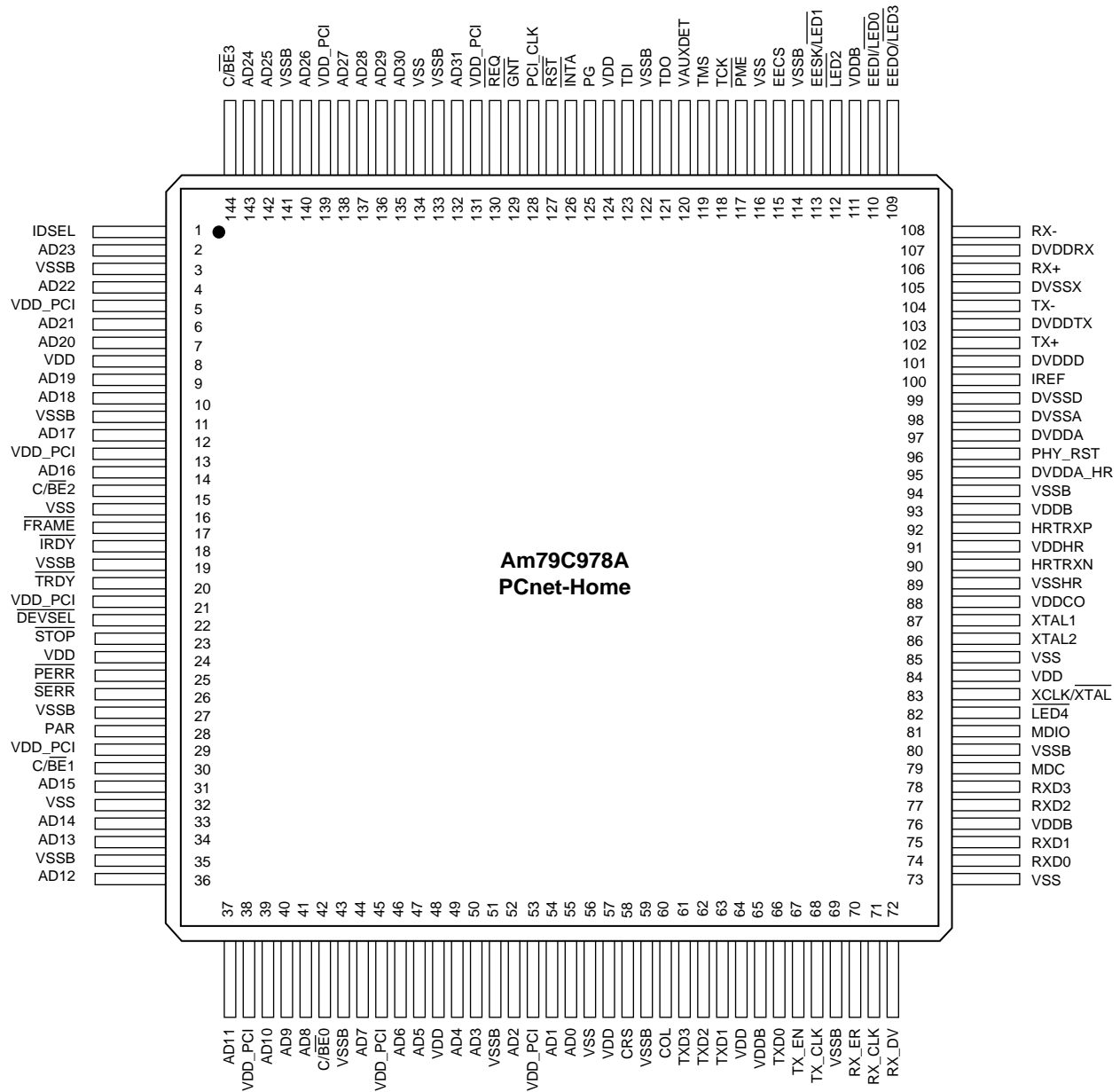

22399A-2

CONNECTION DIAGRAM (160 PQFP)

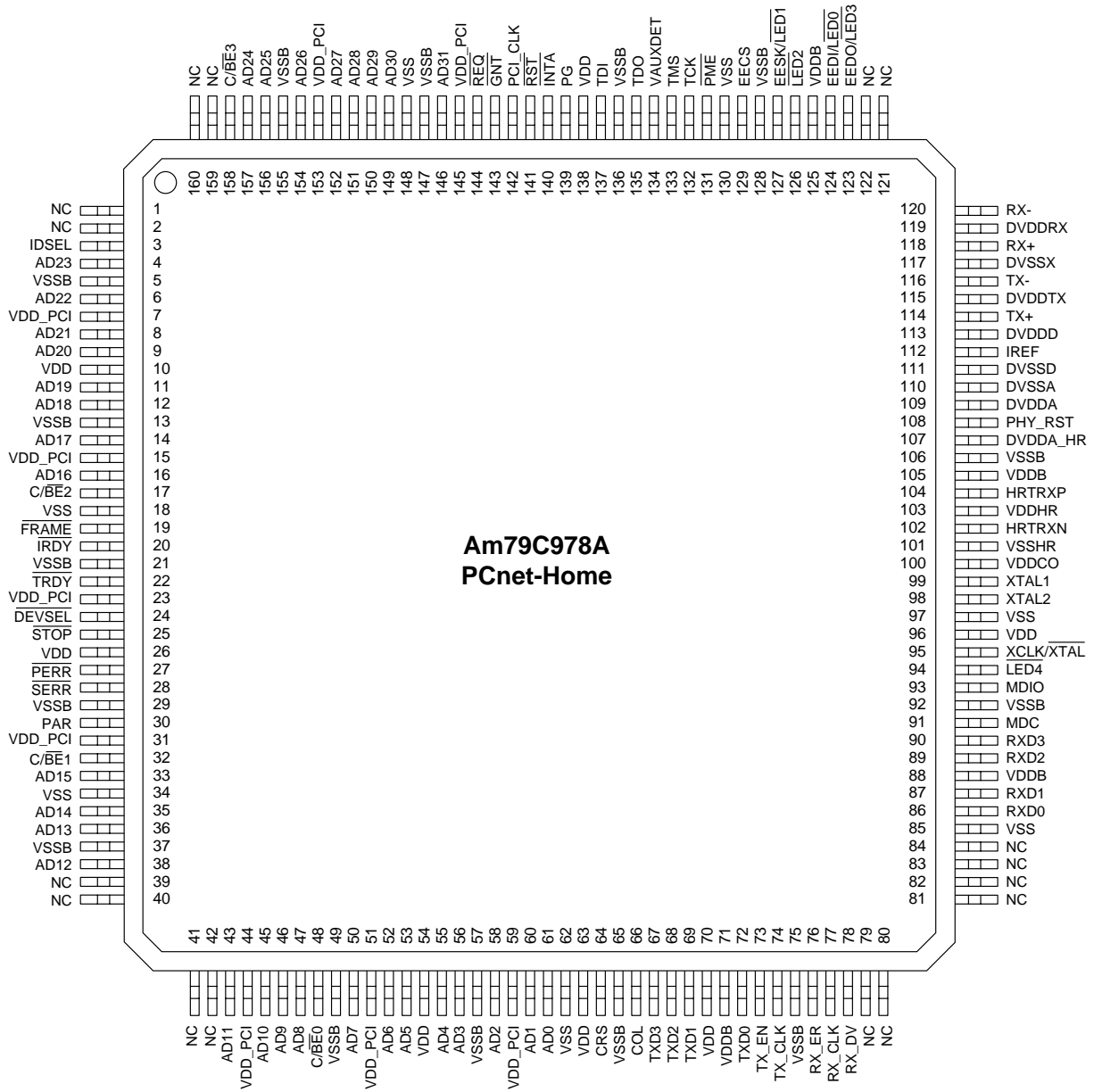

22399A-3

PIN DESIGNATIONS (PQL144)

Listed By Pin Number

Pin No.	Pin Name	Pin No.	Pin Name	Pin No.	Pin Name	Pin No.	Pin Name
1	IDSEL	37	AD11	73	VSS	109	EEDO/LED3
2	AD23	38	VDD_PCI	74	RXD0	110	EEDI/LED0
3	VSSB	39	AD10	75	RXD1	111	Vddb
4	AD22	40	AD9	76	Vddb	112	LED2
5	VDD_PCI	41	AD8	77	RXD2	113	EESK/LED1
6	AD21	42	C/BE0	78	RXD3	114	VSSB
7	AD20	43	VSSB	79	MDC	115	EECS
8	VDD	44	AD7	80	VSSB	116	VSS
9	AD19	45	VDD_PCI	81	MDIO	117	PME
10	AD18	46	AD6	82	LED4	118	TCK
11	VSSB	47	AD5	83	XCLK/XTAL	119	TMS
12	AD17	48	VDD	84	VDD	120	VAUXDET
13	VDD_PCI	49	AD4	85	VSS	121	TDO
14	AD16	50	AD3	86	XTAL2	122	VSSB
15	C/BE2	51	VSSB	87	XTAL1	123	TDI
16	VSS	52	AD2	88	VDDCO	124	VDD
17	FRAME	53	VDD_PCI	89	VSSHR	125	PG
18	IRDY	54	AD1	90	HRTRXN	126	INTA
19	VSSB	55	AD0	91	VDDHR	127	RST
20	TRDY	56	VSS	92	HRTRXP	128	PCI_CLK
21	VDD_PCI	57	VDD	93	Vddb	129	GNT
22	DEVSEL	58	CRS	94	VSSB	130	REQ
23	STOP	59	VSSB	95	DVDDA_HR	131	VDD_PCI
24	VDD	60	COL	96	PHY_RST	132	AD31
25	PERR	61	TXD3	97	DVDDA	133	VSSB
26	SERR	62	TXD2	98	DVSSA	134	VSS
27	VSSB	63	TXD1	99	DVSSD	135	AD30
28	PAR	64	VDD	100	IREF	136	AD29
29	VDD_PCI	65	Vddb	101	DVDDD	137	AD28
30	C/BE1	66	TXD0	102	TX+	138	AD27
31	AD15	67	TX_EN	103	DVDDTX	139	VDD_PCI
32	VSS	68	TX_CLK	104	TX-	140	AD26
33	AD14	69	VSSB	105	DVSSX	141	VSSB
34	AD13	70	RX_ER	106	RX+	142	AD25
35	VSSB	71	RX_CLK	107	DVDDRFX	143	AD24
36	AD12	72	RX_DV	108	RX-	144	C/BE3

PIN DESIGNATIONS (PQR160)

Listed By Pin Number

Pin No.	Pin Name	Pin No.	Pin Name	Pin No.	Pin Name	Pin No.	Pin Name
1	NC	41	NC	81	NC	121	NC
2	NC	42	NC	82	NC	122	NC
3	IDSEL	43	AD11	83	NC	123	EEDO/ $\overline{\text{LED3}}$
4	AD23	44	VDD_PCI	84	NC	124	EEDI/ $\overline{\text{LED0}}$
5	VSSB	45	AD10	85	VSS	125	VDDB
6	AD22	46	AD9	86	RXD0	126	$\overline{\text{LED2}}$
7	VDD_PCI	47	AD8	87	RXD1	127	EESK/ $\overline{\text{LED1}}$
8	AD21	48	C/ $\overline{\text{BE0}}$	88	VDDB	128	VSSB
9	AD20	49	VSSB	89	RXD2	129	EECS
10	VDD	50	AD7	90	RXD3	130	VSS
11	AD19	51	VDD_PCI	91	MDC	131	$\overline{\text{PME}}$
12	AD18	52	AD6	92	VSSB	132	TCK
13	VSSB	53	AD5	93	MDIO	133	TMS
14	AD17	54	VDD	94	$\overline{\text{LED4}}$	134	VAUXDET
15	VDD_PCI	55	AD4	95	XCLK/ $\overline{\text{XTAL}}$	135	TDO
16	AD16	56	AD3	96	VDD	136	VSSB
17	C/ $\overline{\text{BE2}}$	57	VSSB	97	VSS	137	TDI
18	VSS	58	AD2	98	XTAL2	138	VDD
19	$\overline{\text{FRAME}}$	59	VDD_PCI	99	XTAL1	139	PG
20	$\overline{\text{IRDY}}$	60	AD1	100	VDDCO	140	$\overline{\text{INTA}}$
21	VSSB	61	AD0	101	VSSHR	141	$\overline{\text{RST}}$
22	$\overline{\text{TRDY}}$	62	VSS	102	HRTRXN	142	PCI_CLK
23	VDD_PCI	63	VDD	103	VDDHR	143	$\overline{\text{GNT}}$
24	$\overline{\text{DEVSEL}}$	64	CRS	104	HRTRXP	144	$\overline{\text{REQ}}$
25	$\overline{\text{STOP}}$	65	VSSB	105	VDDB	145	VDD_PCI
26	VDD	66	COL	106	VSSB	146	AD31
27	$\overline{\text{PERR}}$	67	TXD3	107	DVDDA_HR	147	VSSB
28	$\overline{\text{SERR}}$	68	TXD2	108	PHY_RST	148	VSS
29	VSSB	69	TXD1	109	DVDDA	149	AD30
30	PAR	70	VDD	110	DVSSA	150	AD29
31	VDD_PCI	71	VDDB	111	DVSSD	151	AD28
32	C/ $\overline{\text{BE1}}$	72	TXD0	112	IREF	152	AD27
33	AD15	73	TX_EN	113	DVDDD	153	VDD_PCI
34	VSS	74	TX_CLK	114	TX+	154	AD26
35	AD14	75	VSSB	115	DVDDTX	155	VSSB
36	AD13	76	RX_ER	116	TX-	156	AD25
37	VSSB	77	RX_CLK	117	DVSSX	157	AD24
38	AD12	78	RX_DV	118	RX+	158	C/ $\overline{\text{BE3}}$
39	NC	79	NC	119	DVDDR_X	159	NC
40	NC	80	NC	120	RX-	160	NC

PIN DESIGNATIONS (PQL144)

Listed By Group

Pin Name	Pin Function	Type	Voltage	Driver	No. of Pins
HomePNA PHY Network Ports					
HRTXRXPN	Receive/Transmit Data	I/O	3.3	NA	2
XTAL1	Crystal Input (20 MHz XTAL/60 MHz CLK)	I	3.3	–	1
XTAL2	Crystal Output (20 MHz XTAL)	O	3.3	XTAL	1
XCLK/XTAL	Oscillator/Crystal Select	I	3.3	–	1
10BASE-T Network Ports					
TX±	Serial Transmit Data	O	3.3	NA	2
RX±	Serial Receive Data	I	3.3	–	2
IREF	Tied to GND via a 12 kΩ 1% resistor	I	3.3	–	1
PHY_RST	Buffered PCI $\overline{\text{RST}}$ signal	O	3.3	OMII1	1
MII					
TX_CLK	MII Transmit Clock	I	3.3	–	1
TXD[3:0]	MII Transmit Data	O	3.3	OMII1	4
TX_EN	MII Transmit Enable	O	3.3	OMII1	1
RX_CLK	MII Receive Clock	I	3.3	–	1
RXD[3:0]	MII Receive Data	I	3.3	–	4
RX_ER	MII Receive Error	I	3.3	–	1
RX_DV	MII Receive Data Valid	I	3.3	–	1
MDC	MII Management Data Clock	O	3.3	OMII2	1
MDIO	MII Management Data I/O	I/O	3.3	TSMII	1
CRS	Carrier Sense	I	3.3	–	1
COL	Collision	I	3.3	–	1
Magic Packet					
$\overline{\text{PME}}$	Power Management Event	O	3.3	OD6	1
PG	Power Good	I	3.3	–	1
Host CPU Interface					
PCI_CLK	CPU Clock	I	3.3/5	–	1
C/ $\overline{\text{BE}}$ [3:0]	Bus Command Byte Enable	I/O	3.3/5	TS3	4
AD[31:0]	Address/Data	I/O	3.3/5	TS3	32
$\overline{\text{DEVSEL}}$	Device Select	I/O	3.3/5	STS6	1
$\overline{\text{FRAME}}$	Cycle Frame	I/O	3.3/5	STS6	1
$\overline{\text{GNT}}$	Bus Grant	I	3.3/5	–	1
IDSEL	Initialization Device Select	I	3.3/5	–	1
$\overline{\text{INTA}}$	Interrupt	O	3.3/5	OD6	1
$\overline{\text{IRDY}}$	Initiator Ready	I/O	3.3/5	STS6	1
PAR	Parity	I/O	3.3/5	STS6	1
$\overline{\text{PERR}}$	Parity Error	I/O	3.3/5	STS6	1
$\overline{\text{REQ}}$	Bus Request	O	3.3/5	TS3	1
$\overline{\text{RST}}$	Reset	I	3.3/5	–	1
$\overline{\text{SERR}}$	System Error	I/O	3.3/5	OD6	1

Pin Name	Pin Function	Type	Voltage	Driver	No. of Pins
$\overline{\text{STOP}}$	Stop	I/O	3.3/5	STS6	1
$\overline{\text{TRDY}}$	Target Ready	I/O	3.3/5	STS6	1
EEPROM/LED Interface					
EECS	Chip Select	O	3.3	O6	1
EEDI/ $\overline{\text{LED0}}$	Data In/LED0	I/O	3.3	LED	1
EESK/ $\overline{\text{LED1}}$	Serial Clock/LED1	O	3.3	LED	1
$\overline{\text{LED2}}$	LED2	O	3.3	LED	1
EEDO/ $\overline{\text{LED3}}$	Data Out/LED3	O	3.3	LED	1
$\overline{\text{LED4}}$	LED4	O	3.3	LED	1
Test Access Port Interface (JTAG)					
TCLK	Test Clock	I	3.3	–	1
TMS	Test Mode Select	I	3.3	–	1
TDI	Test Data In	I	3.3	–	1
TDO	Test Data Out	O	3.3	TS6	1
Power/Ground					
DVDDTX	Transceiver Digital Power	P	3.3	–	1
DVDDR _X	Transceiver Digital Power	P	3.3	–	1
VDD_PCI	Digital Power for the PCI bus	P	3.3	–	9
VDDDB	Digital Power for the PCI bus	P	3.3	–	5
VDD	Digital Power	P	3.3	–	7
VDDHR	Digital Power for HomePNA PHY	P	3.3	–	1
DVDDA	Transceiver Analog Power	P	3.3	–	1
DVDDD	Transceiver Digital Power	P	3.3	–	1
VDDCO	Crystal Oscillator Power	P	3.3	–	1
DVDDA_HR	Transceiver Analog Power	P	3.3	–	1
DVSSD	Transceiver Digital Ground	G	0	–	1
DVSSA	Transceiver Analog Ground	G	0	–	1
DVSSX	Transceiver Ground	G	0	–	1
VSSB	Digital I/O Ground	G	0	–	15
VSS	Digital Ground	G	0	–	7
VSSHR	HomePNA PHY Analog Ground	G	0	–	1

PIN DESIGNATIONS (PQR160)

Listed By Group

Pin Name	Pin Function	Type	Voltage	Driver	No. of Pins
HomePNA PHY Network Ports					
HRTXRXPN	Receive/Transmit Data	I/O	3.3	NA	2
XTAL1	Crystal Input (20 MHz XTAL/60 MHz CLK)	I	3.3	–	1
XTAL2	Crystal Output (20 MHz XTAL)	O	3.3	XTAL	1
XCLK/XTAL	Oscillator/Crystal Select	I	3.3	–	1
10BASE-T Network Ports					
TX±	Serial Transmit Data	O	3.3	NA	2
RX±	Serial Receive Data	I	3.3	–	2
IREF	Tied to GND via a 12 kΩ 1% resistor	I	3.3	–	1
PHY_RST	Buffered PCI $\overline{\text{RST}}$ signal	O	3.3	OMII1	1
MII					
TX_CLK	MII Transmit Clock	I	3.3	–	1
TXD[3:0]	MII Transmit Data	O	3.3	OMII1	4
TX_EN	MII Transmit Enable	O	3.3	OMII1	1
RX_CLK	MII Receive Clock	I	3.3	–	1
RXD[3:0]	MII Receive Data	I	3.3	–	4
RX_ER	MII Receive Error	I	3.3	–	1
RX_DV	MII Receive Data Valid	I	3.3	–	1
MDC	MII Management Data Clock	O	3.3	OMII2	1
MDIO	MII Management Data I/O	I/O	3.3	TSMII	1
CRS	Carrier Sense	I	3.3	–	1
COL	Collision	I	3.3	–	1
Magic Packet					
PME	Power Management Event	O	3.3	OD6	1
PG	Power Good	I	3.3	–	1
Host CPU Interface					
PCI_CLK	CPU Clock	I	3.3/5	–	1
C/ $\overline{\text{BE}}$ [3:0]	Bus Command Byte Enable	I/O	3.3/5	TS3	4
AD[31:0]	Address/Data	I/O	3.3/5	TS3	32
$\overline{\text{DEVSEL}}$	Device Select	I/O	3.3/5	STS6	1
$\overline{\text{FRAME}}$	Cycle Frame	I/O	3.3/5	STS6	1
$\overline{\text{GNT}}$	Bus Grant	I	3.3/5	–	1
IDSEL	Initialization Device Select	I	3.3/5	–	1
$\overline{\text{INTA}}$	Interrupt	O	3.3/5	OD6	1
$\overline{\text{IRDY}}$	Initiator Ready	I/O	3.3/5	STS6	1
PAR	Parity	I/O	3.3/5	STS6	1
$\overline{\text{PERR}}$	Parity Error	I/O	3.3/5	STS6	1
$\overline{\text{REQ}}$	Bus Request	O	3.3/5	TS3	1
$\overline{\text{RST}}$	Reset	I	3.3/5	–	1
$\overline{\text{SERR}}$	System Error	I/O	3.3/5	OD6	1

Pin Name	Pin Function	Type	Voltage	Driver	No. of Pins
$\overline{\text{STOP}}$	Stop	I/O	3.3/5	STS6	1
$\overline{\text{TRDY}}$	Target Ready	I/O	3.3/5	STS6	1
EEPROM/LED Interface					
EECS	Chip Select	O	3.3	O6	1
EEDI/ $\overline{\text{LED0}}$	Data In/LED0	I/O	3.3	LED	1
EESK/ $\overline{\text{LED1}}$	Serial Clock/LED1	O	3.3	LED	1
$\overline{\text{LED2}}$	LED2	O	3.3	LED	1
EEDO/ $\overline{\text{LED3}}$	Data Out/LED3	O	3.3	LED	1
$\overline{\text{LED4}}$	LED4	O	3.3	LED	1
Test Access Port Interface (JTAG)					
TCLK	Test Clock	I	3.3	–	1
TMS	Test Mode Select	I	3.3	–	1
TDI	Test Data In	I	3.3	–	1
TDO	Test Data Out	O	3.3	TS6	1
Power/Ground					
DVDDTX	Transceiver Digital Power	P	3.3	–	1
DVDDR _X	Transceiver Digital Power	P	3.3	–	1
VDD_PCI	Digital Power for the PCI bus	P	3.3	–	9
VDDDB	Digital Power for the PCI bus	P	3.3	–	5
VDD	Digital Power	P	3.3	–	7
VDDHR	Digital Power for HomePNA PHY	P	3.3	–	1
DVDDA	Transceiver Analog Power	P	3.3	–	1
DVDDD	Transceiver Digital Power	P	3.3	–	1
VDDCO	Crystal Oscillator Power	P	3.3	–	1
DVDDA_HR	Transceiver Analog Power	P	3.3	–	1
DVSSD	Transceiver Digital Ground	G	0	–	1
DVSSA	Transceiver Analog Ground	G	0	–	1
DVSSX	Transceiver Ground	G	0	–	1
VSSB	Digital I/O Ground	G	0	–	15
VSS	Digital Ground	G	0	–	7
VSSHR	HomePNA PHY Analog Ground	G	0	–	1

PIN DESIGNATIONS

Listed By Driver Type

The following table describes the various types of output drivers used in the Am79C978A controller. All I_{OL} and I_{OH} values shown in the table apply to 3.3 V signaling.

A sustained tri-state signal is a low active signal that is driven high for one clock period before it is left floating.

TX is a differential output driver. Its characteristics and those of XTAL2 output are described in the *DC CHARACTERISTICS* section.

Driver Name	Type	I_{OL} (mA)	I_{OH} (mA)	Load (pF)
LED	LED	12	0.4	50
O6	Totem Pole	6	0.4	50
OD6	Open Drain	6	NA	50
TS3	Tri-State	3	2	50
TS6	Tri-State	6	2	50
STS6	Sustained Tri-State	6	2	50
OMI1	Tri-State	4	4	50
OMI2	Tri-State	4	4	390
TSMII	Tri-State	4	4	470

ORDERING INFORMATION

Standard Products

AMD standard products are available in several packages and operating ranges. The order number (Valid Combination) is formed by a combination of the elements below.

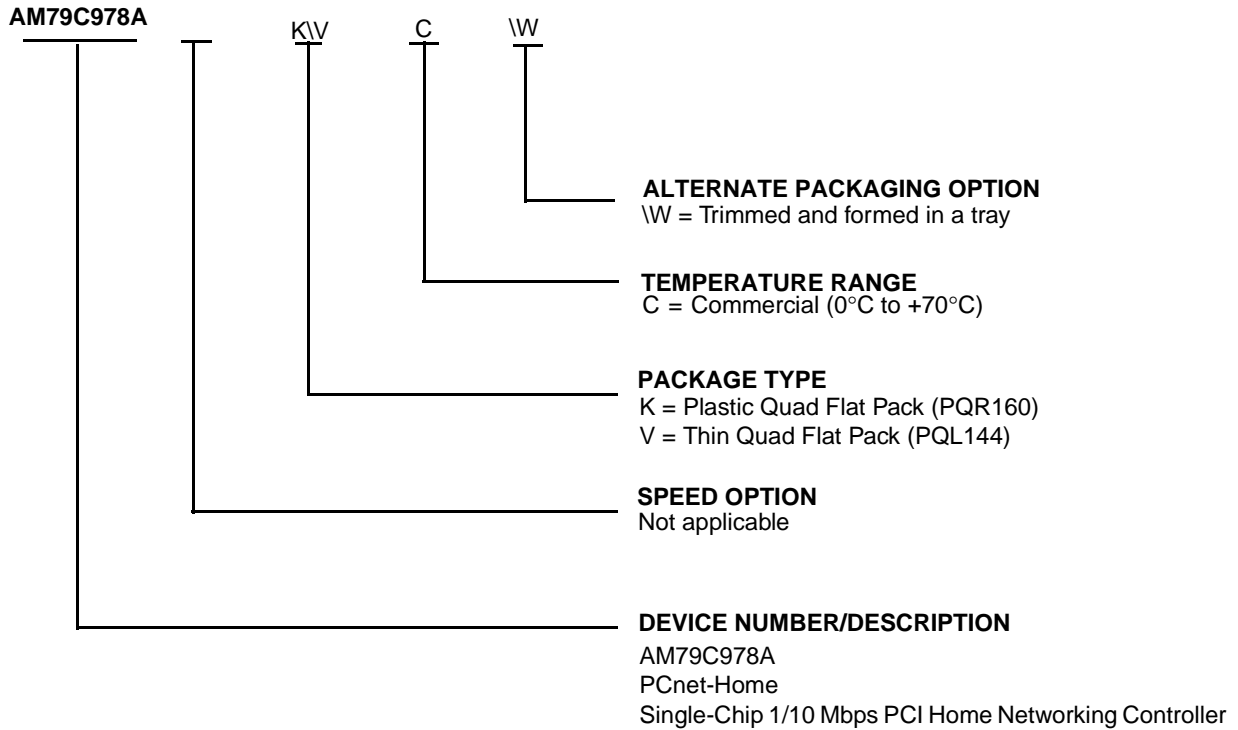

Valid Combinations	
AM79C978A	KC\W VC\W

Valid Combinations

Valid Combinations list configurations planned to be supported in volume for this device. Consult the local AMD sales office to confirm availability of specific valid combinations and to check on newly released combinations.

PIN DESCRIPTIONS

PCI Interface

AD[31:0]

Address and Data

Input/Output

Address and data are multiplexed on the same bus interface pins. During the first clock of a transaction, AD[31:0] contain a physical address (32 bits). During the subsequent clocks, AD[31:0] contain data. Byte ordering is little endian by default. AD[7:0] are defined as the least significant byte (LSB) and AD[31:24] are defined as the most significant byte (MSB). For FIFO data transfers, the Am79C978A controller can be programmed for big endian byte ordering. See CSR3, bit 2 (BSWP) for more details.

During the address phase of the transaction, when the Am79C978A controller is a bus master, AD[31:2] will address the active Double Word (DWord). The Am79C978A controller always drives AD[1:0] to "00" during the address phase indicating linear burst order. When the Am79C978A controller is not a bus master, the AD[31:0] lines are continuously monitored to determine if an address match exists for slave transfers.

During the data phase of the transaction, AD[31:0] are driven by the Am79C978A controller when performing bus master write and slave read operations. Data on AD[31:0] is latched by the Am79C978A controller when performing bus master read and slave write operations.

When \overline{RST} is active, AD[31:0] are inputs for NAND tree testing.

C/ \overline{BE} [3:0]

Bus Command and Byte Enables

Input/Output

Bus command and byte enables are multiplexed on the same bus interface pins. During the address phase of the transaction, C/ \overline{BE} [3:0] define the bus command. During the data phase, C/ \overline{BE} [3:0] are used as byte enables. The byte enables define which physical byte lanes carry meaningful data. C/ \overline{BE} 0 applies to byte 0 (AD[7:0]) and C/ \overline{BE} 3 applies to byte 3 (AD[31:24]). The function of the byte enables is independent of the byte ordering mode (BSWP, CSR3, bit 2).

When \overline{RST} is active, C/ \overline{BE} [3:0] are inputs for NAND tree testing.

PCI_CLK

Clock

Input

This clock is used to drive the system bus interface and the internal buffer management unit. All bus signals are sampled on the rising edge of PCI_CLK and all parameters are defined with respect to this edge. The Am79C978A controller normally operates over a frequency range of 10 to 33 MHz on the

PCI bus due to networking demands. The Am79C978A controller will support a clock frequency of 0 MHz after certain precautions are taken to ensure data integrity. This clock or a derivation is not used to drive any network functions.

When \overline{RST} is active, PCI_CLK is an input for NAND tree testing.

DEVSEL

Device Select

Input/Output

The Am79C978A controller drives \overline{DEVSEL} LOW when it detects a transaction that selects the device as a target. The device samples \overline{DEVSEL} to detect if a target claims a transaction that the Am79C978A controller has initiated.

When \overline{RST} is active, \overline{DEVSEL} is an input for NAND tree testing.

FRAME

Cycle Frame

Input/Output

\overline{FRAME} is driven by the Am79C978A controller when it is the bus master to indicate the beginning and duration of a transaction. \overline{FRAME} is asserted to indicate a bus transaction is beginning. \overline{FRAME} is asserted while data transfers continue. \overline{FRAME} is deasserted before the final data phase of a transaction. When the Am79C978A controller is in slave mode, it samples \overline{FRAME} to determine the address phase of a transaction.

When \overline{RST} is active, \overline{FRAME} is an input for NAND tree testing.

GNT

Bus Grant

Input

This signal indicates that the access to the bus has been granted to the Am79C978A controller.

The Am79C978A controller supports bus parking. When the PCI bus is idle and the system arbiter asserts \overline{GNT} without an active \overline{REQ} from the Am79C978A controller, the device will drive the AD[31:0], C/ \overline{BE} [3:0], and PAR lines.

When \overline{RST} is active, \overline{GNT} is an input for NAND tree testing.

IDSEL

Initialization Device Select

Input

This signal is used as a chip select for the Am79C978A controller during configuration read and write transactions.

When \overline{RST} is active, IDSEL is an input for NAND tree testing.

INTA

Interrupt Request

An attention signal which indicates that one or more of the following status flags is set: EXDINT, IDON, MERR, MISS, MFCO, MPINT, RCVCCO, RINT, SINT, TINT, TXSTRT, UINT, MCCINT, MPDTINT, MAPINT, MREINT, and STINT. Each status flag has either a mask or an enable bit which allows for suppression of INTA assertion. Table 1 shows the flag descriptions. By default INTA is an open-drain output. For applications that need a high-active edge-sensitive interrupt signal, the INTA pin can be configured for this mode by setting INTLEVEL (BCR2, bit 7) to Table 1.

When \overline{RST} is active, \overline{INTA} is the output for NAND tree testing.

Output

Table 1. Interrupt Flags

Name	Description	Mask Bit	Interrupt Bit
EXDINT	Excessive Deferral	CSR5, bit 6	CSR5, bit 7
IDON	Initialization Done	CSR3, bit 8	CSR0, bit 8
MERR	Memory Error	CSR3, bit 11	CSR0, bit 11
MISS	Missed Frame	CSR3, bit 12	CSR0, bit 12
MFCO	Missed Frame Count Overflow	CSR4, bit 8	CSR4, bit 9
MPINT	Magic Packet Interrupt	CSR5, bit 3	CSR5, bit 4
RCVCCO	Receive Collision Count Overflow	CSR4, bit 4	CSR4, bit 5
RINT	Receive Interrupt	CSR3, bit 10	CSR0, bit 10
SINT	System Error	CSR5, bit 10	CSR5, bit 11
TINT	Transmit Interrupt	CSR3, bit 9	CSR0, bit 9
TXSTRT	Transmit Start	CSR4, bit 2	CSR4, bit 3
UINT	User Interrupt	CSR4, bit 7	CSR4, bit 6
MCCINT	MII Management Command Complete Interrupt	CSR7, bit 4	CSR7, bit 5
MPDTINT	MII PHY Detect Transition Interrupt	CSR7, bit 0	CSR7, bit 1
MAPINT	MII Auto-Poll Interrupt	CSR7, bit 6	CSR7, bit 7
MREINT	MII Management Frame Read Error Interrupt	CSR7, bit 8	CSR7, bit 9
STINT	Software Timer Interrupt	CSR7, bit 10	CSR7, bit 11

IRDY

Initiator Ready

IRDY indicates the ability of the initiator of the transaction to complete the current data phase. \overline{IRDY} is used in conjunction with \overline{TRDY} . Wait states are inserted until both \overline{IRDY} and \overline{TRDY} are asserted simultaneously. A data phase is completed on any clock when both \overline{IRDY} and \overline{TRDY} are asserted.

When the Am79C978A controller is a bus master, it asserts \overline{IRDY} during all write data phases to indicate that valid data is present on AD[31:0]. During all read data phases, the device asserts \overline{IRDY} to indicate that it is ready to accept the data.

When the Am79C978A controller is the target of a transaction, it checks \overline{IRDY} during all write data phases to determine if valid data is present on AD[31:0]. During all read data phases, the device checks \overline{IRDY} to determine if the initiator is ready to accept the data.

When \overline{RST} is active, \overline{IRDY} is an input for NAND tree testing.

Input/Output

PAR

Parity

Input/Output

Parity is even parity across AD[31:0] and C/ \overline{BE} [3:0]. When the Am79C978A controller is a bus master, it generates parity during the address and write data phases. It checks parity during read data phases. When the Am79C978A controller operates in slave mode, it checks parity during every address phase. When it is the target of a cycle, it checks parity during write data phases and it generates parity during read data phases.

When \overline{RST} is active, PAR is an input for NAND tree testing.

PERR

Parity Error

Input/Output

During any slave write transaction and any master read transaction, the Am79C978A controller asserts \overline{PERR} when it detects a data parity error and reporting of the error is enabled by setting PERREN (PCI Command register, bit 6) to 1. During any master write transaction, the Am79C978A controller monitors \overline{PERR} to see if the target reports a data parity error.

When \overline{RST} is active, \overline{PERR} is an input for NAND tree testing.

REQ

Bus Request

Input/Output

The Am79C978A controller asserts \overline{REQ} pin as a signal that it wishes to become a bus master. \overline{REQ} is driven high when the Am79C978A controller does not request the bus. In Power Management mode, the \overline{REQ} pin will not be driven.

When \overline{RST} is active, \overline{REQ} is an input for NAND tree testing.

\overline{RST}

Reset

Input

When \overline{RST} is asserted LOW and the PG pin is HIGH, then the Am79C978A controller performs an internal system reset of the type H_RESET (HARDWARE_RESET, see section on RESET). \overline{RST} must be held for a minimum of 30 clock periods. While in the H_RESET state, the Am79C978A controller will disable or deassert all outputs. \overline{RST} may be asynchronous to clock when asserted or deasserted.

When the PG pin is LOW, \overline{RST} disables all of the PCI pins except the PME pin.

When \overline{RST} is LOW and PG is HIGH, NAND tree testing is enabled.

\overline{SERR}

System Error

Output

During any slave transaction, the Am79C978A controller asserts \overline{SERR} when it detects an address parity error, and reporting of the error is enabled by setting PERREN (PCI Command register, bit 6) and SERREN (PCI Command register, bit 8) to 1.

By default \overline{SERR} is an open-drain output. For component test, it can be programmed to be an active-high totem-pole output.

When \overline{RST} is active, \overline{SERR} is an input for NAND tree testing.

\overline{STOP}

Stop

Input/Output

In slave mode, the Am79C978A controller drives the \overline{STOP} signal to inform the bus master to stop the current transaction. In bus master mode, the Am79C978A controller checks \overline{STOP} to determine if the target wants to disconnect the current transaction.

When \overline{RST} is active, \overline{STOP} is an input for NAND tree testing.

\overline{TRDY}

Target Ready

Input/Output

\overline{TRDY} indicates the ability of the target of the transaction to complete the current data phase. Wait states are inserted until both \overline{IRDY} and \overline{TRDY} are asserted simultaneously. A data phase is completed on any clock when both \overline{IRDY} and \overline{TRDY} are asserted.

When the Am79C978A controller is a bus master, it checks \overline{TRDY} during all read data phases to determine if valid data is present on AD[31:0]. During all write data phases, the device checks \overline{TRDY} to determine if the target is ready to accept the data.

When the Am79C978A controller is the target of a transaction, it asserts \overline{TRDY} during all read data phases to indicate that valid data is present on AD[31:0]. During all write data phases, the device asserts \overline{TRDY} to indicate that it is ready to accept the data.

When \overline{RST} is active, \overline{TRDY} is an input for NAND tree testing.

Magic Packet Interface

\overline{PME}

Power Management Event Output, Open Drain

\overline{PME} is an output that can be used to indicate that a power management event (a Magic Packet, an OnNow pattern match, or a change in link state) has been detected. The PME pin is asserted when either

1. PME_STATUS and PME_EN are both 1,
2. PME_EN_OVR and MPMAT are both 1, or
3. PME_EN_OVR and LCDET are both 1.

The \overline{PME} signal is asynchronous with respect to the PCI clock. See the *Power Saving Mode* section for detailed description.

$\overline{VAUXDET}$

Auxiliary Power Detect

Input

$\overline{VAUXDET}$ is used to sense the presence of the auxiliary power and correctly report the capability of asserting \overline{PME} signal in D3 cold. The $\overline{VAUXDET}$ pin should be connected to the auxiliary power supply or to ground through a resistor. If PCI power is used to power the device, a pull-down resistor is required. For systems that provide auxiliary power, the $\overline{VAUXDET}$ pin should be tied to auxiliary power through a pull-up resistor.

PG

Power Good

Input

The PG pin has two functions: (1) it puts the device into Magic Packet mode, and (2) it blocks any resets when the PCI bus power is off.

When PG is LOW and either MPPEN or MPMODE is set to 1, the device enters Magic Packet mode.

When PG is LOW, a LOW assertion of the PCI \overline{RST} pin will only cause the PCI interface pins (except for \overline{PME}) to be put in the high impedance state. The internal logic will ignore the assertion of \overline{RST} .

When PG is HIGH, assertion of the PCI \overline{RST} pin causes the controller logic to be reset and the configuration information to be loaded from the EEPROM.

Note: PG input should be kept high during NAND tree testing.

Board Interface

Note: Before programming the LED pins, see the description of LEDPE in BCR2, bit 12.

LED0

LED0

Output

This output is designed to directly drive an LED. By default, $\overline{\text{LED0}}$ indicates an active link connection. This pin can also be programmed to indicate other network status (see BCR4). The $\overline{\text{LED0}}$ pin polarity is programmable, but by default it is active LOW. When the $\overline{\text{LED0}}$ pin polarity is programmed to active LOW, the output is an open drain driver. When the $\overline{\text{LED0}}$ pin polarity is programmed to active HIGH, the output is a totem pole driver.

Note: The $\overline{\text{LED0}}$ pin is multiplexed with the EEDI pin.

LED1

LED1

Output

This output is designed to directly drive an LED. By default, $\overline{\text{LED1}}$ indicates receive activity on the network. This pin can also be programmed to indicate other network status (see BCR5). The $\overline{\text{LED1}}$ pin polarity is programmable, but by default, it is active LOW. When the $\overline{\text{LED1}}$ pin polarity is programmed to active LOW, the output is an open drain driver. When the $\overline{\text{LED1}}$ pin polarity is programmed to active HIGH, the output is a totem pole driver.

Note: The $\overline{\text{LED1}}$ pin is multiplexed with the EESK pin.

The $\overline{\text{LED1}}$ pin is also used during EEPROM Auto-Detection to determine whether or not an EEPROM is present at the Am79C978A controller interface. At the last rising edge of CLK while $\overline{\text{RST}}$ is active LOW, $\overline{\text{LED1}}$ is sampled to determine the value of the EEDET bit in BCR19. It is important to maintain adequate hold time around the rising edge of the CLK at this time to ensure a correctly sampled value. A sampled HIGH value means that an EEPROM is present, and EEDET will be set to 1. A sampled LOW value means that an EEPROM is not present, and EEDET will be set to 0. See the *EEPROM Auto-Detection* section for more details.

If no LED circuit is to be attached to this pin, then a pull-up or pull-down resistor must be attached instead in order to ground the EEDET setting.

WARNING: The input signal level of $\overline{\text{LED1}}$ must be insured for correct EEPROM detection before the deassertion of $\overline{\text{RST}}$.

LED2

LED2

Output

This output is designed to directly drive an LED. This pin can be programmed to indicate various network

status (see BCR6). The $\overline{\text{LED2}}$ pin polarity is programmable, but by default it is active LOW. When the $\overline{\text{LED2}}$ pin polarity is programmed to active LOW, the output is an open drain driver. When the $\overline{\text{LED2}}$ pin polarity is programmed to active HIGH, the output is a totem pole driver.

LED3

LED3

Output

This output is designed to directly drive an LED. By default, $\overline{\text{LED3}}$ indicates transmit activity on the network. This pin can also be programmed to indicate other network status (see BCR7). The $\overline{\text{LED3}}$ pin polarity is programmable, but by default it is active LOW. When the $\overline{\text{LED3}}$ pin polarity is programmed to active LOW, the output is an open drain driver. When the $\overline{\text{LED3}}$ pin polarity is programmed to active HIGH, the output is a totem pole driver.

Special attention must be given to the external circuitry attached to this pin. When this pin is used to drive an LED while an EEPROM is used in the system, then buffering may be required between the $\overline{\text{LED3}}$ pin and the LED circuit. If an LED circuit were directly attached to this pin, it may create an I_{OL} requirement that could not be met by the serial EEPROM attached to this pin. If no EEPROM is included in the system design or low current LEDs are used, then the $\overline{\text{LED3}}$ signal may be directly connected to an LED without buffering. For more details regarding LED connection, see the section on *LED Support*.

Note: The $\overline{\text{LED3}}$ pin is multiplexed with the EEDO pin.

LED4

LED4

Output

This output is designed to directly drive an LED. This pin can be programmed to indicate various network status (see BCR48). The $\overline{\text{LED4}}$ pin polarity is programmable, but by default it is active LOW. When the $\overline{\text{LED4}}$ pin polarity is programmed to active LOW, the output is an open drain driver. When the $\overline{\text{LED4}}$ pin polarity is programmed to active HIGH, the output is a totem pole driver.

EEPROM Interface

EECS

EEPROM Chip Select

Output

This pin is designed to directly interface to a serial EEPROM that uses the 93C46 EEPROM interface protocol. EECS is connected to the EEPROM's chip select pin. It is controlled by either the Am79C978A controller during command portions of a read of the entire EEPROM, or indirectly by the host system by writing to BCR19, bit 2.

EEDI

EEPROM Data In

Output

This pin is designed to directly interface to a serial EEPROM that uses the 93C46 EEPROM interface protocol. EEDI is connected to the EEPROM's data input pin. It is controlled by either the Am79C978A controller during command portions of a read of the entire EEPROM, or indirectly by the host system by writing to BCR19, bit 0.

Note: The EEDI pin is multiplexed with the $\overline{LED0}$ pin.

EEDO

EEPROM Data Out

Input

This pin is designed to directly interface to a serial EEPROM that uses the 93C46 EEPROM interface protocol. EEDO is connected to the EEPROM's data output pin. It is controlled by either the Am79C978A controller during command portions of a read of the entire EEPROM, or indirectly by the host system by reading from BCR19, bit 0.

Note: The EEDO pin is multiplexed with the $\overline{LED3}$ pin.

EESK

EEPROM Serial Clock

Output

This pin is designed to directly interface to a serial EEPROM that uses the 93C46 EEPROM interface protocol. EESK is connected to the EEPROM's clock pin. It is controlled by either the Am79C978A controller directly during a read of the entire EEPROM, or indirectly by the host system by writing to BCR19, bit 1.

Note: The EESK pin is multiplexed with the $\overline{LED1}$ pin.

The EESK pin is also used during EEPROM Auto-Detection to determine whether or not an EEPROM is present at the Am79C978A controller interface. At the rising edge of the last CLK edge while \overline{RST} is asserted, EESK is sampled to determine the value of the EEDET bit in BCR19. A sampled HIGH value means that an EEPROM is present, and EEDET will be set to 1. A sampled LOW value means that an EEPROM is not present, and EEDET will be set to 0. See the *EEPROM Auto-Detection* section for more details.

If no LED circuit is to be attached to this pin, then a pull-up or pull-down resistor must be attached instead to resolve the EEDET setting.

WARNING: The input signal level of EESK must be valid for correct EEPROM detection before the deassertion of \overline{RST} .

MII Interface

RX_CLK

Receive Clock

Input

RX_CLK is a clock input that provides the timing reference for the transfer of the RX_DV, RXD[3:0], and

RX_ER signals into the Am79C978A device. RX_CLK must provide a nibble rate clock (25% of the network data rate). Hence, when the Am79C978A device is operating at 10 Mbps, it provides an RX_CLK frequency of 2.5 MHz, and at 100 Mbps it provides an RX_CLK frequency of 25 MHz.

RXD[3:0]

Receive Data

Input

RXD[3:0] is the nibble-wide MII-compatible receive data bus. Data on RXD[3:0] is sampled on every rising edge of RX_CLK while RX_DV is asserted. RXD[3:0] is ignored while RX_DV is de-asserted.

RX_DV

Receive Data Valid

Input

RX_DV is an input used to indicate that valid received data is being presented on the RXD[3:0] pins and RX_CLK is synchronous to the receive data. In order for a frame to be fully received by the Am79C978A device, RX_DV must be asserted prior to the RX_CLK rising edge, when the first nibble of the Start of Frame Delimiter is driven on RXD[3:0], and must remain asserted until after the rising edge of RX_CLK, when the last nibble of the CRC is driven on RXD[3:0]. RX_DV must then be deasserted prior to the RX_CLK rising edge which follows this final nibble. RX_DV transitions are synchronous to RX_CLK rising edges.

CRS

Receive Carrier Sense

Input

CRS is an input that indicates that a non-idle medium, due either to transmit or receive activity, has been detected.

COL

Collision

Input

COL is an input that indicates that a collision has been detected on the network medium.

RX_ER

Receive Error

Input

RX_ER is an input that indicates that the MII transceiver device has detected a coding error in the receive data frame currently being transferred on the RXD[3:0] pins. If RX_ER is asserted while RX_DV is asserted, a CRC error will be indicated in the receive descriptor for the incoming receive frame. RX_ER is ignored while RX_DV is deasserted. Special code groups generated on RXD while RX_DV is deasserted are ignored (e.g., bad SSD in TX and idle in T4). RX_ER transitions are synchronous to RX_CLK.

TX_CLK

Transmit Clock **Input**

TX_CLK is a clock input that provides the timing reference for the transfer of the TXD[3:0] and TX_ER signals into the Am79C978A device. TX_CLK must provide a nibble rate clock (25% of the network data rate). Hence, when the Am79C978A device is operating at 10 Mbps, it provides an TX_CLK frequency of 2.5 MHz, and at 100 Mbps it provides an RX_CLK frequency of 25 MHz.

TXD[3:0]

Transmit Data **Output**

TXD[3:0] is the nibble-wide MII-compatible transmit data bus. Valid data is generated on TXD[3:0] on every rising edge of TX_CLK while TX_EN is asserted. While TX_EN is deasserted, TXD[3:0] values are driven to 0. TXD[3:0] transitions are synchronous to rising edges of TX_CLK

TX_EN

Transmit Enable **Output**

TX_EN indicates when the Am79C978A device is presenting valid transmit nibbles on the MII TXD[3:0] bus. While TX_EN is asserted, the Am79C978A device generates TXD[3:0] and TX_ER on TX_CLK rising edges. TX_EN is asserted with the first nibble of preamble and remains asserted throughout the duration of the packet until it is deasserted prior to the first TX_CLK following the final nibble of the frame. TX_EN transitions are synchronous to TX_CLK.

MDC

Management Data Clock **Output**

MDC is the non-continuous clock output that provides a timing reference for bits on the MDIO pin. During MII management port operations, MDC runs at a nominal frequency of 2.5 MHz. When no management operations are in progress, MDC is driven LOW.

If the MII port is not selected, the MDC pin may be left floating.

MDIO

Management Data Input/Output **Input/Output**

MDIO is a bidirectional MII management port data pin. MDIO is an output during the header portion of the management frame transfers and during the data portion of write operations. MDIO is an input during the data portion of read operations.

If a PHY is attached to the MII port via a MII physical connector then the MDIO pin should be externally pulled down to V_{SS} with a 10 K Ω $\pm 5\%$ resistor. If a PHY is directly attached to the MII pins then the

MDIO pin should be externally pulled up to V_{CC} with a 10 k Ω $\pm 5\%$ resistor.

IEEE 1149.1 (1990) Test Access Port Interface

TCK

Test Clock **Input**

TCK is the clock input for the boundary scan test mode operation. It can operate at a frequency of up to 10 MHz. TCK has an internal pull-up resistor.

TDI

Test Data In **Input**

TDI is the test data input path to the Am79C978A controller. The pin has an internal pull-up resistor.

TDO

Test Data Out **Output**

TDO is the test data output path from the Am79C978A controller. The pin is tri-stated when the JTAG port is inactive.

TMS

Test Mode Select **Input**

A serial input bit stream on the TMS pin is used to define the specific boundary scan test to be executed. The pin has an internal pull-up resistor.

Ethernet Network Interfaces

TX \pm

Serial Transmit Data **Output**

These pins carry the transmit output data and are connected to the transmit side of the magnetics module.

RX \pm

Serial Receive Data **Input**

These pins accept the receive input data from the magnetics module.

IREF

Internal Current Reference **Input**

This pin serves as a current reference for the integrated 1/10 PHY. It must be connected to V_{SS} through a 12 k Ω resistor (1%).

PHY_RST

PHY Reset **Output**

This output is used to reset the external PHY. This output eliminates the need for a fanout buffer on the PCI reset (RST) signal, provided polarity control for the specific PHY used, and prevents the resetting of the PHY when the PG input is LOW. The output polarity is determined by the RST_POL (CRS116, bit0).

HomePNA PHY Network Interface

HRTXRX/HRTRXN

Serial Receive Data

Input/Output

These pins accept the receive input data from the magnetics module and carry the transmit output data. A 100- Ω resistor should be placed between these pins.

Clock Interface

XCLK/XTAL

External Clock/Crystal Select

Input

When HIGH, an external 60-MHz clock source is selected bypassing the crystal circuit and clock tripler. When LOW, a 20-MHz crystal is used instead. The following table illustrates how this pin works.

Table 2. External Clock/Crystal Select

Input Pin	Output Pin	XCLK/XTAL	Clock Source
XTAL1	XTAL2	0	20-MHz Crystal
XTAL1	Don't Care	1	60-MHz Oscillator/ External CLK Source

XTAL1

Crystal Oscillator In

Input

The internal clock generator utilizes either a 20-MHz crystal that is attached to pins XTAL1 and XTAL2 or a 60-MHz clock source connected to XTAL1. This pin is not 5 V tolerant, and the 60 MHz clock source should be from a 3.3 V source, not a 5 V clock source.

XTAL2

Crystal Oscillator Out

Output

The internal clock generator utilizes either a 20-MHz crystal that is attached to pins XTAL1 and XTAL2 or a 60-MHz clock source connected to XTAL1.

External Crystal Characteristics

When using a crystal to drive the oscillator, the following crystal specification in Table 3 may be used to ensure less than ± 0.5 ns jitter at DO_{\pm} .

Table 3. Crystal Characteristics

Parameter	Min	Nom	Max	Units
1. Parallel Resonant Frequency		20		MHz
2. Resonant Frequency Error	-50		+50	PPM
3. Change in Resonant Frequency With Respect To Temperature (0-70°C)*	-40		+40	PPM
4. Crystal Load Capacitance	15	18	33	pF
5. Motional Crystal Capacitance (C1)		0.022		pF
6. Internal Equivalent Series Resistance			50	ohm
7. Shunt Capacitance			7	pF

Note: *Requires trimming specification; not trimmed is 50 PPM total.

Power Supply

VDD

I/O Buffer Power (4 Pins)

+3.3 V Power

These pins are the power supply pins that are used by the input/output buffer drivers. All VDD pins must be connected to a +3.3 V supply.

VDD_PCI

PCI I/O Buffer Power (9 Pins)

+3.3 V Power

These pins are the power supply pins that are used by the PCI input/output buffer drivers (except \overline{PME} driver). All VDD_PCI pins must be connected to a +3.3 V supply.

VSSB

I/O Buffer Ground (15 Pins)

Ground

These pins are the ground pins that are used by the input/output buffer drivers.

VDD

Digital Power (7 Pins)

+3.3 V Power

These pins are the power supply pins that are used by the internal digital circuitry. All VDD pins must be connected to a +3.3 V supply.

VSS

Digital Ground (7 Pins)

Ground

There are seven ground pins that are used by the internal digital circuitry.

DVDDD**10BASE-T PDX Block Power** **+3.3 V Power**

This pin supplies power to the 10 Mbps Transceiver block. It must be connected to a +3.3 V $\pm 5\%$ source. This pin requires careful decoupling to ensure proper device performance.

DVDDR_X, DVDDT_X**10BASE-T I/O Buffer Power** **+3.3 V Power**

These pins supply power to the 10BASE-T input/output buffers. They must be connected to a +3.3 V $\pm 5\%$ source. These pins require careful decoupling to ensure proper device performance.

DVDDA**Analog PLL Power** **+3.3 V Power**

This pin supplies power to the IREF current reference circuit and the 10BASE-T analog PLL. They must be connected to a +3.3 V $\pm 5\%$ source. These pins require careful decoupling to ensure proper device performance.

DVSS_X, DVSSA**10BASE-T PDX Analog Ground** **Ground**

These pins are the ground connection for the analog section within the Physical Data Transceiver (PDX) block.

DVSSD**10BASE-T PDX Digital Ground** **Ground**

This pin is the ground connection for the digital logic within the PDX block.

VDDCO**Crystal** **+3.3 V Power**

This pin supplies power to the crystal circuit.

VDDHR**HomePNA Digital Power** **+3.3 V Power**

These pins are the digital power supply pins that are used by the internal digital circuitry for the HomePNA block. They must be connected to a +3.3 V source.

VSSHR**HomePNA Analog Ground** **Ground**

This pin is the ground connection for the analog section within the HomePNA block.

DVDDA_HR**HomePNA Analog Power** **+3.3 V Power**

This pin supplies power to the analog section of the HomePNA block. It must be connected to a +3.3 V $\pm 5\%$ source. This pin requires careful decoupling to ensure proper device performance.

BASIC FUNCTIONS

System Bus Interface

The Am79C978A controller is designed to operate as a bus master during normal operations. Some slave I/O accesses to the Am79C978A controller are required in normal operations as well. Initialization of the Am79C978A controller is achieved through a combination of PCI Configuration Space accesses, bus slave accesses, bus master accesses, and an optional read of a serial EEPROM that is performed by the Am79C978A controller. The EEPROM read operation is performed through the 93C46 EEPROM interface. The ISO 8802-3 (IEEE/ANSI 802.3) Ethernet Address may reside within the serial EEPROM. Some controller configuration registers may also be programmed by the EEPROM read operation.

The Address PROM, on-chip board-configuration registers, and the Ethernet controller registers occupy 32 bytes of address space. I/O and memory mapped I/O accesses are supported. Base Address registers in the PCI configuration space allow locating the address space on a wide variety of starting addresses.

Software Interface

The software interface to the Am79C978A controller is divided into three parts. One part is the PCI configuration registers used to identify the Am79C978A controller and to setup the configuration of the device. The setup information includes the I/O or memory mapped I/O base address, mapping of the Expansion ROM, and the routing of the Am79C978A controller interrupt channel. This allows for a jumperless implementation.

The second portion of the software interface is the direct access to the I/O resources of the Am79C978A controller. The Am79C978A controller occupies 32 bytes of address space that must begin on a 32-byte block boundary. The address space can be mapped into I/O or memory space (memory mapped I/O). The I/O Base Address Register in the PCI Configuration Space controls the start address of the address space if it is mapped to I/O space. The Memory Mapped I/O Base Address Register controls the start address of the address space if it is mapped to memory space. The 32-byte address space is used by the software to program the Am79C978A controller operating mode, to enable and disable various features, to monitor operating status, and to request particular functions to be executed by the Am79C978A controller.

The third portion of the software interface is the descriptor and buffer areas that are shared between the software and the Am79C978A controller during normal network operations. The descriptor area boundaries are set by the software and do not

change during normal network operations. There is one descriptor area for receive activity, and there is a separate area for transmit activity. The descriptor space contains relocatable pointers to the network frame data, and it is used to transfer frame status from the Am79C978A controller to the software. The buffer areas are locations that hold frame data for transmission or that accept frame data that has been received.

Network Interfaces

The Am79C978A controller provides all of the PHY layer functions for 10 Mbps (10BASE-T) or 1 Mbps. The Am79C978A controller supports both half-duplex and full-duplex operation on the network MII interface.

Media Independent Interface

The Am79C978A controller fully supports the MII according to the IEEE 802.3 standard. This Reconciliation Sublayer interface allows a variety of PHYs (100BASE-TX, 100BASE-FX, 100BASE-T4, 100BASE-T2, 10BASE-T, etc.) to be attached to the Am79C978A device without future upgrade problems. The MII interface is a 4-bit (nibble) wide data path interface that runs at 25 MHz for 100-Mbps networks or 2.5 MHz for 10-Mbps networks. The interface consists of two independent data paths, receive (RXD(3:0)) and transmit (TXD(3:0)), control signals for each data path (RX_ER, RX_DV, TX_EN), network status signals (COL, CRS), clocks (RX_CLK, TX_CLK) for each data path, and a two-wire management interface (MDC and MDIO). See Figure 1.

MII Transmit Interface

The MII transmit clock is generated by the external PHY and is sent to the Am79C978A controller on the TX_CLK input pin. The clock can run at 25 MHz or 2.5 MHz, depending on the speed of the network to which the external PHY is attached. The data is a nibble-wide (4 bits) data path, TXD(3:0), from the Am79C978A controller to the external PHY and is synchronous to the rising edge of TX_CLK. The transmit process starts when the Am79C978A controller asserts the TX_EN, which indicates to the external PHY that the data on TXD(3:0) is valid.

Normally, unrecoverable errors are signaled through the MII to the external PHY with the TX_ER output pin. The external PHY will respond to this error by generating a TX coding error on the current transmitted frame. The Am79C978A controller does not use this method of signaling errors on the transmit side. The Am79C978A controller will invert the FCS on the last byte generating an invalid FCS. The TX_ER pin should be tied to GND.

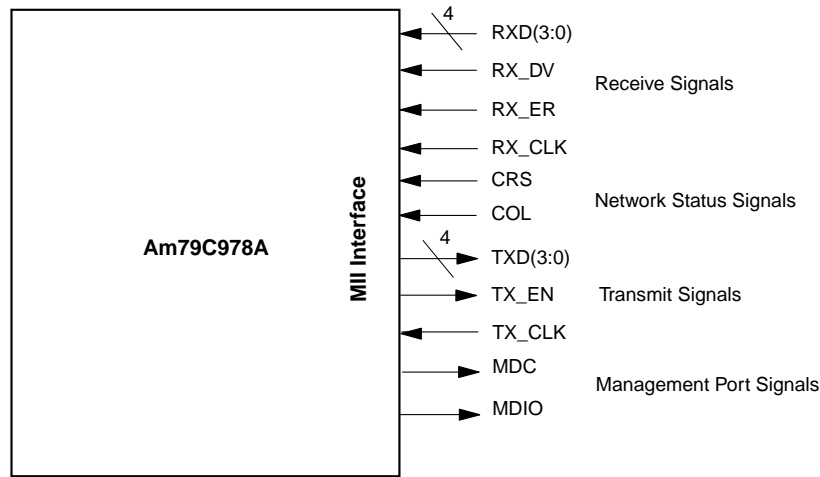

22399A-4

Figure 1. Media Independent Interface

MII Receive Interface

The MII receive clock is also generated by the external PHY and is sent to the Am79C978A controller on the RX_CLK input pin. The clock will be the same frequency as the TX_CLK but will be out of phase and can run at 25 MHz or 2.5 MHz, depending on the speed of the network to which the external PHY is attached.

The RX_CLK is a continuous clock during the reception of the frame, but can be stopped for up to two RX_CLK periods at the beginning and the end of frames, so that the external PHY can sync up to the network data traffic necessary to recover the receive clock. During this time, the external PHY may switch to the TX_CLK to maintain a stable clock on the receive interface. The Am79C978A controller will handle this situation with no loss of data. The data is a nibble-wide (4 bits) data path, RXD(3:0), from the external PHY to the Am79C978A controller and is synchronous to the rising edge of RX_CLK.

The receive process starts when RX_DV is asserted. RX_DV will remain asserted until the end of the receive frame. The Am79C978A controller requires CRS (Carrier Sense) to toggle in between frames in order to receive them properly. Errors in the currently received frame are signaled across the MII by the RX_ER pin. RX_ER can be used to signal special conditions *out of band* when RX_DV is not asserted. Two defined out-of-band conditions for this are the 100BASE-TX signaling of *bad* Start of Frame Delimiter and the 100BASE-T4 indication of illegal code group before the receiver has *synced* to the incoming data. The Am79C978A controller will not respond to these conditions. All *out of band* conditions are currently treated as NULL events. Certain *in band* non-IEEE 802.3u-compliant flow control sequences may cause erratic behavior for the Am79C978A controller.

MII Network Status Interface

The MII also provides signals that are consistent and necessary for IEEE 802.3 and IEEE 802.3u operation. These signals are CRS (Carrier Sense) and COL (Collision Sense). Carrier Sense is used to detect non-idle activity on the network. Collision Sense is used to indicate that simultaneous transmission has occurred in a half-duplex network.

MII Management Interface

The MII provides a two-wire management interface so that the Am79C978A controller can control and receive status from external PHY devices.

The Network Port Manager copies the PHYAD after the Am79C978A controller reads the EEPROM and uses it to communicate with the external PHY. The PHY address must be programmed into the EEPROM prior to starting the Am79C978A controller. This is necessary so that the internal management controller can work autonomously from the software driver and can always know where to access the external PHY. The Am79C978A controller is unique by offering direct hardware support of the external PHY device without software support. The PHY address of 1Fh is reserved and should not be used. To access the external PHYs, the software driver must have knowledge of the external PHY's address when multiple PHYs are present before attempting to address it.

The MII Management Interface uses the MII Control, Address, and Data registers (BCR32, 33, 34) to control and communicate to the external PHYs. The Am79C978A controller generates MII management frames to the external PHY through the MDIO pin synchronous to the rising edge of the Management Data Clock (MDC) based on a combination of writes and reads to these registers.

MII Management Frames

MII management frames are automatically generated by the Am79C978A controller and conform to the MII clause in the IEEE 802.3u standard.

The start of the frame is a preamble of 32 ones and guarantees that all of the external PHYs are synchronized on the same interface. See Figure 2. Loss of synchronization is possible due to the *hot-plugging* capability of the exposed MII.

The IEEE 802.3 specification allows you to drop the preamble, if after reading the MII Status Register from the external PHY you can determine that the external PHY will support Preamble Suppression (BCR34, bit 6). After having a valid MII Status Register read, the Am79C978A controller will then drop the creation of the preamble stream until a reset occurs, receives a read error, or the external PHY is disconnected.

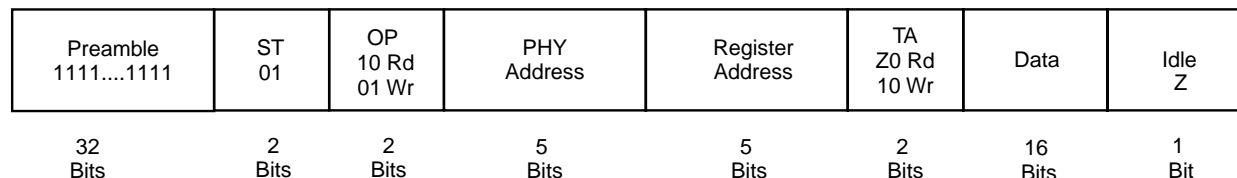

22399A-5

Figure 2. Frame Format at the MII Interface Connection

This is followed by a start field (ST) and an operation field (OP). The operation field (OP) indicates whether the Am79C978A controller is initiating a read or write operation. This is followed by the external PHY address (PHYAD) and the register address (REGAD) programmed in BCR33. The PHY address of 1Fh is reserved and should not be used. The external PHY may have a larger address space starting at 10h - 1Fh. This is the address range set aside by the IEEE as vendor usable address space and will vary from vendor to vendor. This field is followed by a bus turnaround field. During a read operation, the bus turnaround field is used to determine if the external PHY is responding correctly to the read request or not. The Am79C978A controller will tri-state the MDIO for both MDC cycles.

During the second cycle, if the external PHY is synchronized to the Am79C978A controller, the external PHY will drive a 0. If the external PHY does not drive a 0, the Am79C978A controller will signal a MREINT (CSR7, bit 9) interrupt, if MREINTE (CSR7, bit 8) is set to a 1, indicating the Am79C978A controller had an MII management frame read error and that the data in BCR34 is not valid. The data field to/from the external PHY is read or written into the BCR34 register. The last field is an IDLE field that is necessary to give ample time for drivers to turn off before the next access. The Am79C978A controller will drive the MDC to 0 and tri-state the MDIO anytime the MII Management Port is not active.

To help to speed up the reading and of writing the MII management frames to the external PHY, the MDC can be sped up to 10 MHz by setting the FMDC bits in BCR32. The IEEE 802.3 specification requires use of

the 2.5-MHz clock rate, but 5 MHz and 10 MHz are available for the user. The intended applications are that the 10-MHz clock rate can be used for a single external PHY on an adapter card or motherboard. The 5-MHz clock rate can be used for an exposed MII with one external PHY attached. The 2.5-MHz clock rate is intended to be used when multiple external PHYs are connected to the MII Management Port or if compliance to the IEEE 802.3u standard is required.

Auto-Poll External PHY Status Polling

As defined in the IEEE 802.3 standard, the external PHY attached to the Am79C978A controller's MII has no way of communicating important timely status information back to Am79C978A controller. The Am79C978A controller has no way of knowing that an external PHY has undergone a change in status without polling the MII status register. To prevent problems from occurring with inadequate host or software polling, the Am79C978A controller will Auto-Poll when APEP (BCR32, bit 11) is set to 1 to insure that the most current information is available. See *10BASE-T PHY Management Registers* for the bit descriptions of the MII Status Register. The contents of the latest read from the external PHY will be stored in a shadow register in the Auto-Poll block. The first read of the MII Status Register will just be stored, but subsequent reads will be compared to the contents already stored in the shadow register. If there has been a change in the contents of the MII Status Register, a MAPINT (CSR7, bit 5) interrupt will be generated on $\overline{\text{INTA}}$ if the MAPINTE (CSR7, bit 4) is set to 1. The Auto-Poll features can be disabled if software driver polling is required.

The Auto-Poll's frequency of generating MII management frames can be adjusted by setting of the APDW bits (BCR32, bits 10-8). The delay can be adjusted from 0 MDC periods to 2048 MDC periods. Auto-Poll by default will only read the MII Status register in the external PHY.

Network Port Manager

If the external PHY is present and is active, the Network Port Manager will request status from the external PHY by generating MII management frames. These frames will be sent roughly every 900 ms. These frames are necessary so that the Network Port Manager can monitor the current active link and can select a different network port if the current link goes down.

10BASE-T PHY

The 10BASE-T transceiver incorporates the physical layer function, including both clock recovery (ENDEC) and transceiver function. Data transmission over the 10BASE-T medium requires an integrated 10BASE-T MAU. The transceiver will meet the electrical requirements for 10BASE-T as specified in IEEE 802.3i. The transmit signal is filtered on the transceiver to reduce harmonic content per IEEE 802.3i. Since filtering is performed in silicon, external filtering modules are not needed. The 10BASE-T PHY transceiver receives 10 Mbps data from the MAC across the internal MII at 2.5 million nibbles per second (parallel), or 10 million bits per second (serial) for 10BASE-T. It then Manchester encodes the data before transmission to the network.

The RX± pins are differential twisted-pair receivers. When properly terminated, each receiver will meet the electrical requirements for 10BASE-T as specified in IEEE 802.3i. Each receiver has internal filtering and does not require external filter modules. The 10BASE-T PHY transceiver receives a Manchester coded 10BASE-T data stream from the medium. It then recovers the clock and decodes the data. The data stream is presented at the internal MII interface in either parallel or serial format.

PCI and JTAG Configuration Information

The PCI device ID and software configuration information is as follows in Table 4 and Table 5.

Table 4. PCI Device ID

Vendor ID	Device ID	Rev ID (offset 0x08)
1022	2001	52

Table 5. PCI Software Configuration

CSR89	CSR88	JTAG
00002262	00006003h	2262 6003h

Slave Bus Interface Unit

The slave Bus Interface Unit (BIU) controls all accesses to the PCI configuration space, the Control and Status Registers (CSR), the Bus Configuration Registers (BCR), the Address PROM (APROM) locations, and the Expansion ROM. Table 6 shows the response of the Am79C978A controller to each of the PCI commands in slave mode.

Table 6. Slave Commands

C[3:0]	Command	Use
0000	Interrupt Acknowledge	Not used
0001	Special Cycle	Not used
0010	I/O Read	Read of CSR, BCR, APROM, and Reset registers
0011	I/O Write	Write to CSR, BCR, and APROM
0100	Reserved	
0101	Reserved	
0110	Memory Read	Memory mapped I/O read of CSR, BCR, APROM, and Reset registers. Read of the Expansion Bus
0111	Memory Write	Memory mapped I/O write of CSR, BCR, and APROM
1000	Reserved	
1001	Reserved	
1010	Configuration Read	Read of the Configuration Space
1011	Configuration Write	Write to the Configuration Space
1100	Memory Read Multiple	Aliased to Memory Read
1101	Dual Address Cycle	Not used
1110	Memory Read Line	Aliased to Memory Read
1111	Memory Write Invalidate	Aliased to Memory Write

Slave Configuration Transfers

The host can access the PCI configuration space with a configuration read or write command. The Am79C978A controller will assert \overline{DEVSEL} during the address phase when $IDSEL$ is asserted, $AD[1:0]$ are both 0, and the access is a configuration cycle. $AD[7:2]$ select the DWord location in the configuration space. The Am79C978A controller ignores $AD[10:8]$, because

it is a single function device. AD[31:11] are “don't cares.” See Table 7.

Table 7. Slave Configuration Transfers

AD31 AD11	AD10 AD8	AD7 AD2	AD1	AD0
Don't care	Don't care	DWord Index	0	0

The active bytes within a DWord are determined by the byte enable signals. Eight-bit, 16-bit, and 32-bit transfers are supported. $\overline{\text{DEVSEL}}$ is asserted two clock cycles after the host has asserted $\overline{\text{FRAME}}$. All configuration cycles are of fixed length. The Am79C978A controller will assert $\overline{\text{TRDY}}$ on the third clock of the data phase.

The Am79C978A controller does not support burst transfers for access to configuration space. When the host keeps $\overline{\text{FRAME}}$ asserted for a second data phase, the Am79C978A controller will disconnect the transfer.

When the host tries to access the PCI configuration space while the automatic read of the EEPROM after H_RESET (see section on RESET) is on-going, the Am79C978A controller will terminate the access on the PCI bus with a disconnect/retry response.

The Am79C978A controller supports fast back-to-back transactions to different targets. This is indicated by the Fast Back-To-Back Capable bit (PCI Status register, bit 7), which is hardwired to 1. The Am79C978A controller is capable of detecting a configuration cycle even when its address phase immediately follows the data phase of a transaction to a different target without any idle state in-between. There will be no contention on the $\overline{\text{DEVSEL}}$, $\overline{\text{TRDY}}$, and $\overline{\text{STOP}}$ signals, since the Am79C978A controller asserts $\overline{\text{DEVSEL}}$ on the second clock after $\overline{\text{FRAME}}$ is asserted (medium timing).

Slave I/O Transfers

After the Am79C978A controller is configured as an I/O device by setting IOEN (for regular I/O mode) or MEMEN (for memory mapped I/O mode) in the PCI Command register, it starts monitoring the PCI bus for access to its CSR, BCR, or EEPROM locations. If configured for regular I/O mode, the Am79C978A controller will look for an address that falls within its 32 bytes of I/O address space (starting from the I/O base address). The

Am79C978A controller asserts $\overline{\text{DEVSEL}}$ if it detects an address match and the access is an I/O cycle. If configured for memory mapped I/O mode, the Am79C978A controller will look for an address that falls within its 32 bytes of memory address space (starting from the memory mapped I/O base address). The Am79C978A controller asserts $\overline{\text{DEVSEL}}$ if it detects an address match and the access is a memory cycle. $\overline{\text{DEVSEL}}$ is asserted two clock cycles after the host has asserted $\overline{\text{FRAME}}$. See Figure 3 and Figure 4.

The Am79C978A controller will not assert $\overline{\text{DEVSEL}}$ if it detects an address match and the PCI command is not of the correct type. In memory mapped I/O mode, the Am79C978A controller aliases all accesses to the I/O resources of the command types *Memory Read Multiple* and *Memory Read Line* to the basic Memory Read command. All accesses of the type *Memory Write and Invalidate* are aliased to the basic Memory Write command. Eight-bit, 16-bit, and 32-bit non-burst transactions are supported. The Am79C978A controller decodes all 32 address lines to determine which I/O resource is accessed.

The typical number of wait states added to a slave I/O or memory mapped I/O read or write access on the part of the Am79C978A controller is six to seven clock cycles, depending upon the relative phases of the internal Buffer Management Unit clock and the CLK signal, since the internal Buffer Management Unit clock is a divide-by-two version of the CLK signal.

The Am79C978A controller does not support burst transfers for access to its I/O resources. When the host keeps $\overline{\text{FRAME}}$ asserted for a second data phase, the Am79C978A controller will disconnect the transfer.

The Am79C978A controller supports fast back-to-back transactions to different targets. This is indicated by the Fast Back-To-Back Capable bit (PCI Status register, bit 7), which is hardwired to 1. The Am79C978A controller is capable of detecting an I/O or a memory-mapped I/O cycle even when its address phase immediately follows the data phase of a transaction to a different target, without any idle state in-between. There will be no contention on the $\overline{\text{DEVSEL}}$, $\overline{\text{TRDY}}$, and $\overline{\text{STOP}}$ signals, since the Am79C978A controller asserts $\overline{\text{DEVSEL}}$ on the second clock after $\overline{\text{FRAME}}$ is asserted (medium timing). See Figure 5 and Figure 6.

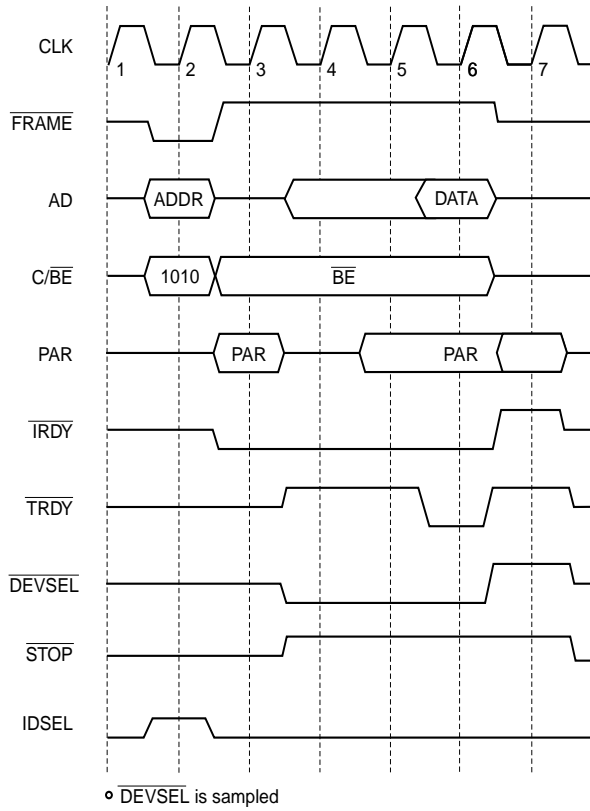

22399A-6

Figure 3. Slave Configuration Read

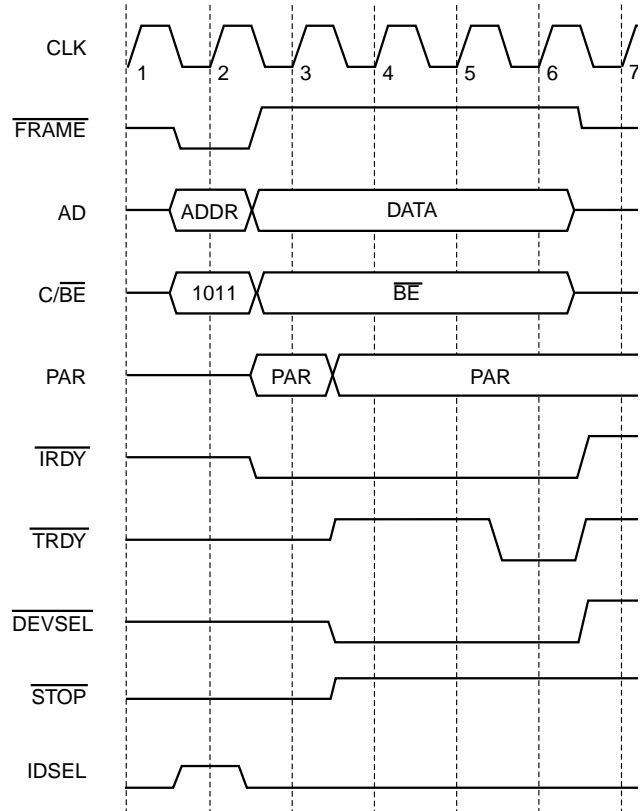

22399A-7

Figure 4. Slave Configuration Write

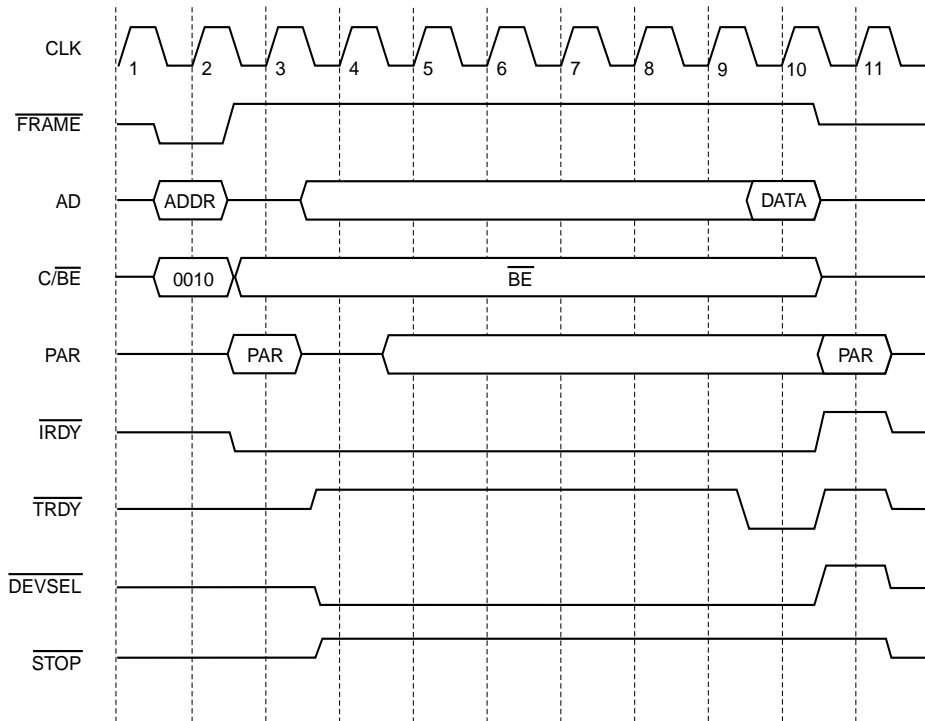

22399A-8

Figure 5. Slave Read Using I/O Command

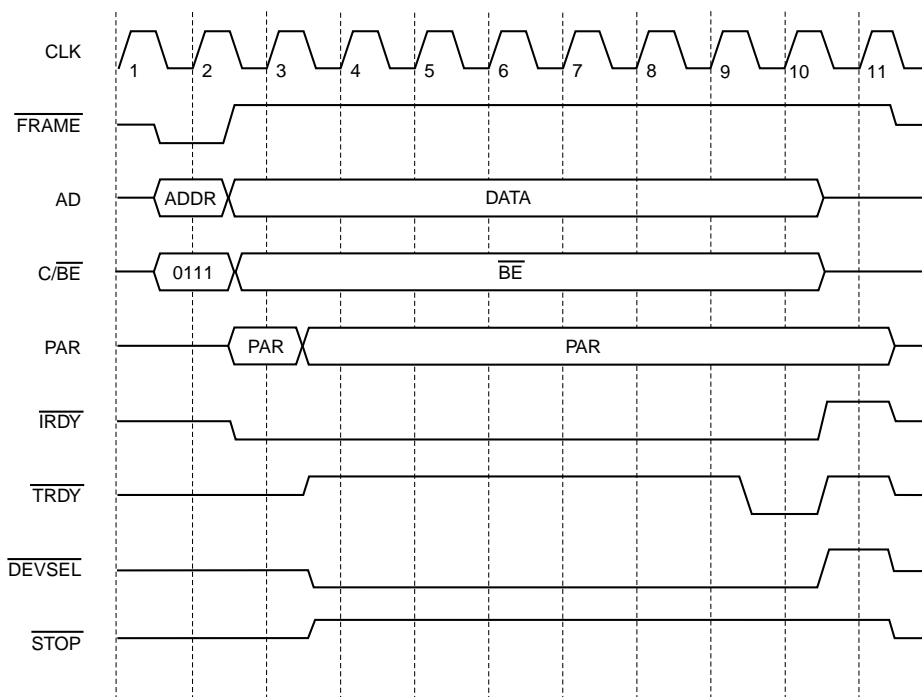

22399A-9

Figure 6. Slave Write Using Memory Command

Expansion ROM Transfers

The host must initialize the Expansion ROM Base Address register at offset 30H in the PCI configuration space with a valid address before enabling access to the device. The Am79C978A controller will not react to any access to the Expansion ROM until both MEMEN (PCI Command register, bit 1) and ROMEN (PCI Expansion ROM Base Address register, bit 0) are set to 1. After the Expansion ROM is enabled, the Am79C978A controller will assert $\overline{\text{DEVSEL}}$ on all memory read accesses with an address between ROMBASE and ROMBASE + 1M - 4. The Am79C978A controller aliases all accesses to the Expansion ROM of the command types *Memory Read Multiple* and *Memory Read Line* to the basic Memory Read command. Eight-bit, 16-bit, and 32-bit read transfers are supported.

Since setting MEMEN also enables memory mapped access to the I/O resources, attention must be given the PCI Memory Mapped I/O Base Address register before enabling access to the Expansion ROM. The host must set the PCI Memory Mapped I/O Base Address register to a value that prevents the Am79C978A controller from claiming any memory cycles not intended for it.

The Am79C978A controller will always read four bytes for every host Expansion ROM read access. $\overline{\text{TRDY}}$ will not be asserted until all four bytes are loaded into an internal scratch register. The cycle $\overline{\text{TRDY}}$ is asserted depends on the programming of the Expansion ROM interface timing. Figure 7 assumes that ROMTMG (BCR18, bits 15-12) is at its default value.

Note: *The Expansion ROM should be read only during PCI configuration time for the PCI system.*

When the host tries to write to the Expansion ROM, the Am79C978A controller will claim the cycle by asserting $\overline{\text{DEVSEL}}$. $\overline{\text{TRDY}}$ will be asserted one clock cycle later. The write operation will have no effect. Writes to the Expansion ROM are done through the BCR30 Expansion Bus Data Port. See the *Expansion Bus Interface* section for more details.

During the boot procedure, the system will try to find an Expansion ROM. A PCI system assumes that an Expansion ROM is present when it reads the ROM signature 55H (byte 0) and AAH (byte 1).

Slave Cycle Termination

There are three scenarios besides normal completion of a transaction where the Am79C978A controller is the target of a slave cycle and it will terminate the access.

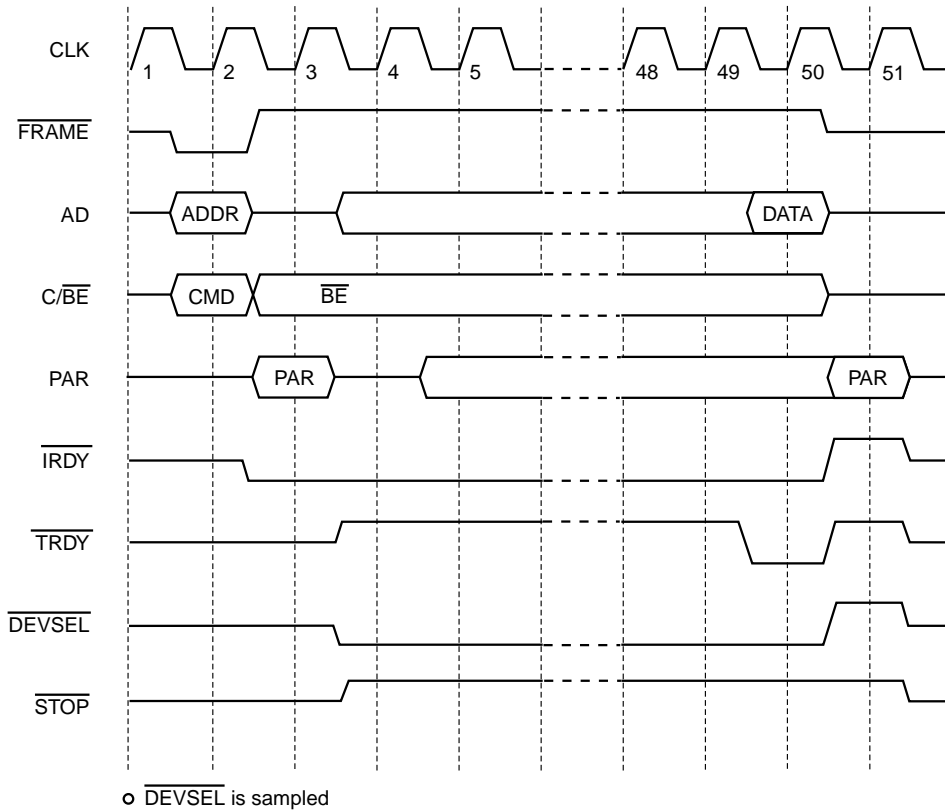

22399A-10

Figure 7. Expansion ROM Read

Disconnect When Busy

The Am79C978A controller cannot service any slave access while it is reading the contents of the EEPROM. Simultaneous access is not allowed in order to avoid conflicts, since the EEPROM is used to initialize some of the PCI configuration space locations and most of the BCRs and CSR116. The EEPROM read operation will always happen automatically after the deassertion of the RST pin. In addition, the host can start the read operation by setting the PREAD bit (BCR19, bit 14). While the EEPROM read is on-going, the Am79C978A controller will disconnect any slave access where it is the target by asserting STOP together with DEVSEL, while driving TRDY high. STOP will stay asserted until the end of the cycle.

Note that I/O and memory slave accesses will only be disconnected if they are enabled by setting the IOEN or MEMEN bit in the PCI Command register. Without the enable bit set, the cycles will not be claimed at all. Since H_RESET clears the IOEN and MEMEN bits for the automatic EEPROM read after H_RESET, the disconnect only applies to configuration cycles.

A second situation where the Am79C978A controller will generate a PCI disconnect/retry cycle is when the host tries to access any of the I/O resources right after having

read the Reset register. Since the access generates an internal reset pulse of about 1 ms in length, all further slave accesses will be deferred until the internal reset operation is completed. See Figure 8.

Disconnect Of Burst Transfer

The Am79C978A controller does not support burst access to the configuration space, the I/O resources, or to the Expansion Bus. The host indicates a burst transaction by keeping FRAME asserted during the data phase. When the Am79C978A controller sees FRAME and IRDY asserted in the clock cycle before it wants to assert TRDY, it also asserts STOP at the same time. The transfer of the first data phase is still successful, since IRDY and TRDY are both asserted. See Figure 9.

If the host is not yet ready when the Am79C978A controller asserts TRDY, the device will wait for the host to assert IRDY. When the host asserts IRDY and FRAME is still asserted, the Am79C978A controller will finish the first data phase by deasserting TRDY one clock later. At the same time, it will assert STOP to signal a disconnect to the host. STOP will stay asserted until the host removes FRAME. See Figure 10.

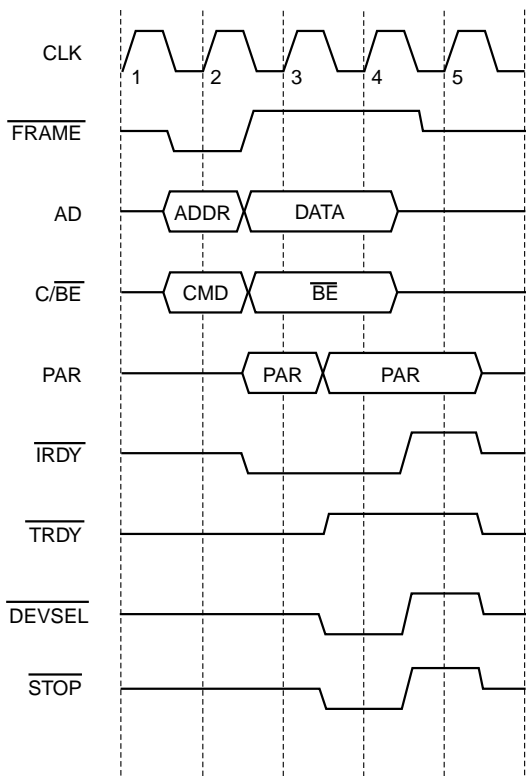

22399A-11

Figure 8. Disconnect of Slave Cycle When Busy

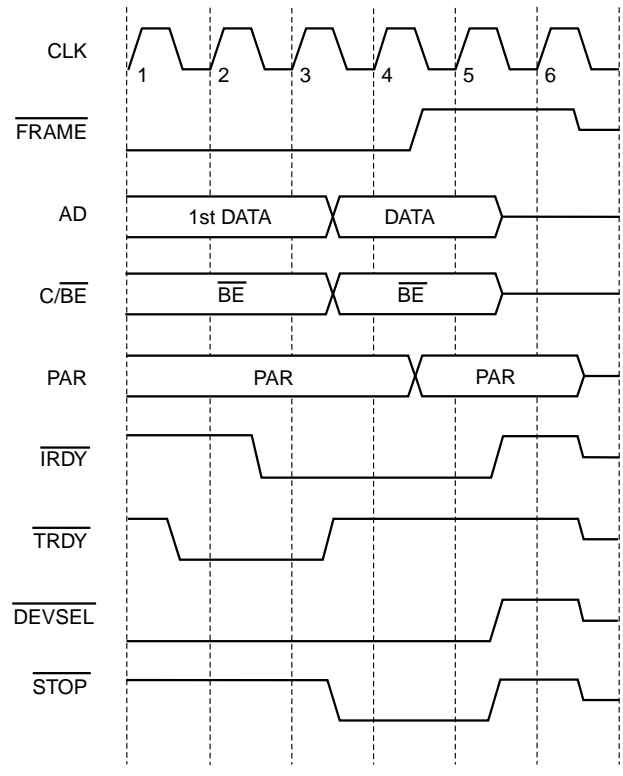

22399A-13

Figure 10. Disconnect of Slave Burst Transfer - Host Inserts Wait States

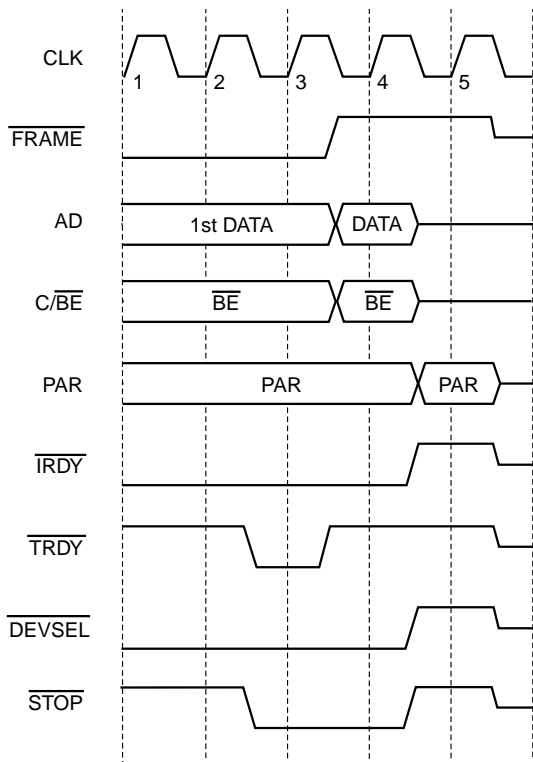

22399A-12

Figure 9. Disconnect of Slave Burst Transfer - No Host Wait States

Parity Error Response

When the Am79C978A controller is not the current bus master, it samples the AD[31:0], C/BE[3:0], and the PAR lines during the address phase of any PCI command for a parity error. When it detects an address parity error, the Am79C978A controller sets PERR (PCI Status register, bit 15) to 1. When reporting of that error is enabled by setting SERREN (PCI Command register, bit 8) and PERREN (PCI Command register, bit 6) to 1, the Am79C978A controller also drives the $\overline{\text{SERR}}$ signal low for one clock cycle and sets SERR (PCI Status register, bit 14) to 1. The assertion of $\overline{\text{SERR}}$ follows the address phase by two clock cycles. The Am79C978A controller will not assert $\overline{\text{DEVSEL}}$ for a PCI transaction that has an address parity error when PERREN and SERREN are set to 1. See Figure 11.

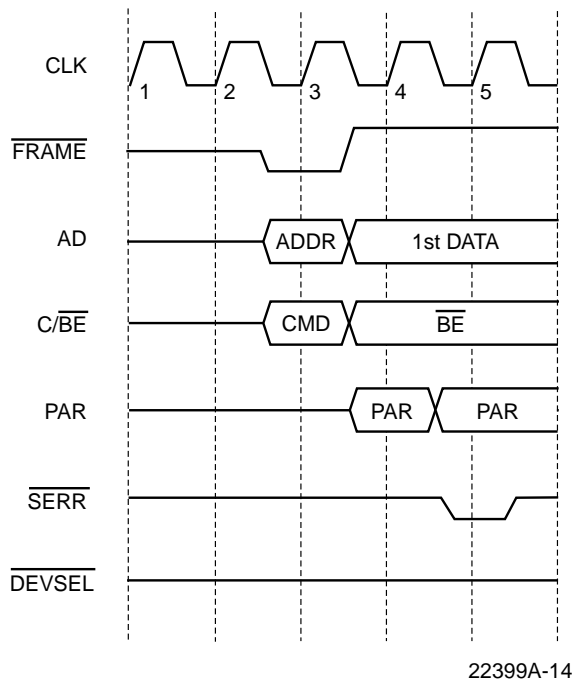

Figure 11. Address Parity Error Response

During the data phase of an I/O write, memory-mapped I/O write, or configuration write command that selects the Am79C978A controller as target, the device samples the AD[31:0] and C/BE[3:0] lines for parity on the clock edge, and data is transferred as indicated by the assertion of $\overline{\text{IRDY}}$ and $\overline{\text{TRDY}}$. PAR is sampled in the following clock cycle. If a parity error is detected and reporting of that error is enabled by setting PERREN (PCI Command register, bit 6) to 1, $\overline{\text{PERR}}$ is asserted one clock later. The parity error will always set PERR (PCI Status register, bit 15) to 1 even when PERREN is cleared to 0. The Am79C978A controller will finish a transaction that has a data parity error in the normal way by asserting $\overline{\text{TRDY}}$. The corrupted data will be written to the addressed location.

Figure 12 shows a transaction that suffered a parity error at the time data was transferred (clock 7, $\overline{\text{IRDY}}$ and $\overline{\text{TRDY}}$ are both asserted). $\overline{\text{PERR}}$ is driven high at the beginning of the data phase and then drops low due to the parity error on clock 9, two clock cycles after the data was transferred. After $\overline{\text{PERR}}$ is driven low, the Am79C978A controller drives $\overline{\text{PERR}}$ high for one clock cycle, since $\overline{\text{PERR}}$ is a sustained tri-state signal.

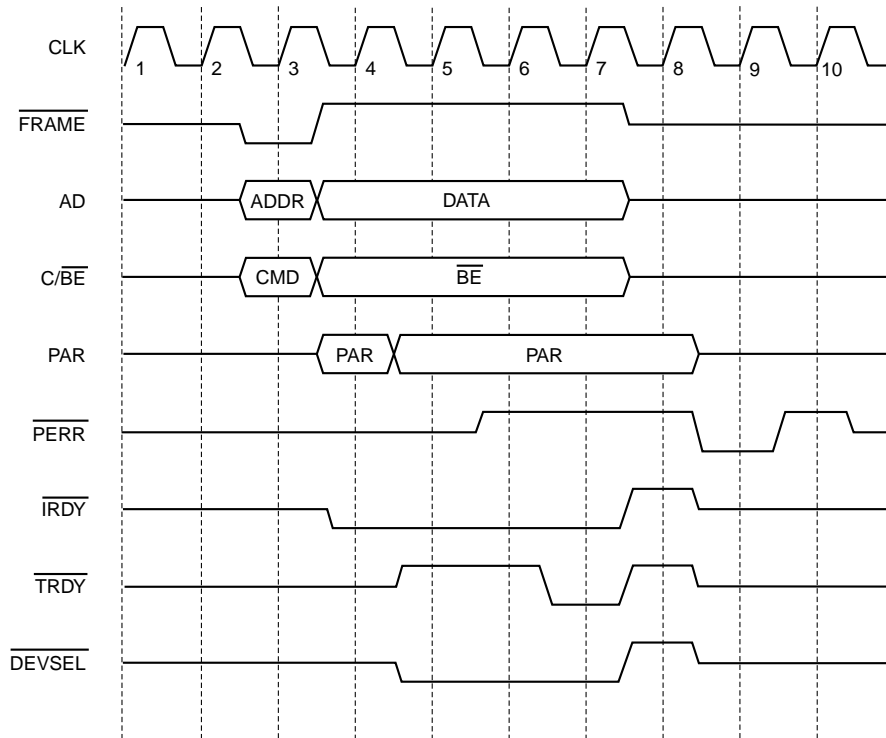

Figure 12. Slave Cycle Data Parity Error Response

Master Bus Interface Unit

The master Bus Interface Unit (BIU) controls the acquisition of the PCI bus and all accesses to the initialization block, descriptor rings, and the receive and transmit buffer memory. Table 8 shows the usage of PCI commands by the Am79C978A controller in master mode.

Table 8. Master Commands

C[3:0]	Command	Use
0000	Interrupt Acknowledge	Not used
0001	Special Cycle	Not used
0010	I/O Read	Not used
0011	I/O Write	Not used
0100	Reserved	
0101	Reserved	
0110	Memory Read	Read of the initialization block and descriptor rings Read of the transmit buffer in non-burst mode
0111	Memory Write	Write to the descriptor rings and to the receive buffer
1000	Reserved	
1001	Reserved	
1010	Configuration Read	Not used
1011	Configuration Write	Not used
1100	Memory Read Multiple	Read of the transmit buffer in burst mode
1101	Dual Address Cycle	Not used
1110	Memory Read Line	Read of the transmit buffer in burst mode
1111	Memory Write Invalidate	Not used

Bus Acquisition

The microcode will determine when a DMA transfer should be initiated. The first step in any bus master transfer is to acquire ownership of the bus. This task is handled by synchronous logic within the BIU. Bus ownership is requested with the \overline{REQ} signal and ownership is granted by the arbiter through the \overline{GNT} signal.

Figure 13 shows the Am79C978A controller bus acquisition. \overline{REQ} is asserted and the arbiter returns \overline{GNT} while another bus master is transferring data. The Am79C978A controller waits until the bus is idle (\overline{FRAME} and \overline{IRDY} deasserted) before it starts driving AD[31:0] and C/BE[3:0] on clock 5. \overline{FRAME} is asserted at clock 5 indicating a valid address and command on AD[31:0] and C/BE[3:0]. The Am79C978A controller does not use address stepping which is reflected by ADSTEP (bit 7) in the PCI Command register being hardwired to 0.

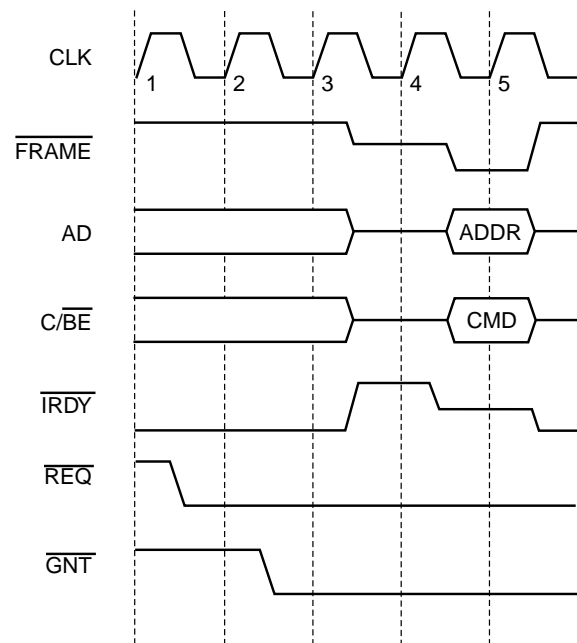

Figure 13. Bus Acquisition

22399A-16

In burst mode, the deassertion of \overline{REQ} depends on the setting of EXTREQ (BCR18, bit 8). If EXTREQ is cleared to 0, \overline{REQ} is deasserted at the same time as \overline{FRAME} is asserted. (The Am79C978A controller never performs more than one burst transaction within a single bus mastership period.) If EXTREQ is set to 1, the Am79C978A controller does not deassert \overline{REQ} until it starts the last data phase of the transaction.

Once asserted, \overline{REQ} remains active until \overline{GNT} has become active and independent of subsequent setting of STOP (CSR0, bit 2) or SPND (CSR5, bit 0). The assertion of H_RESET or S_RESET, however, will cause \overline{REQ} to go inactive immediately.

Bus Master DMA Transfers

There are four primary types of DMA transfers. The Am79C978A controller uses non-burst as well as burst cycles for read and write access to the main memory.

Basic Non-Burst Read Transfer

By default, the Am79C978A controller uses non-burst cycles in all bus master read operations. All controller non-burst read accesses are of the PCI command type Memory Read (type 6). Note that during a non-burst read operation, all byte lanes will always be active. The Am79C978A controller will internally discard unneeded bytes.

The Am79C978A controller typically performs more than one non-burst read transaction within a single bus mastership period. \overline{FRAME} is dropped between consecutive non-burst read cycles. \overline{REQ} stays asserted until \overline{FRAME} is asserted for the last transaction. The

Am79C978A controller supports zero wait state read cycles. It asserts $\overline{\text{IRDY}}$ immediately after the address phase and at the same time starts sampling $\overline{\text{DEVSEL}}$. Figure 14 shows two non-burst read transactions. The first transaction has zero wait states. In the second transaction, the target extends the cycle by asserting $\overline{\text{TRDY}}$ one clock later.

Basic Burst Read Transfer

The Am79C978A controller supports burst mode for all bus master read operations. The burst mode must be enabled by setting BREADE (BCR18, bit 6). To allow burst transfers in descriptor read operations, the Am79C978A controller must also be programmed to use SWSTYLE 3 (BCR20, bits 7-0). All burst read accesses to the initialization block and descriptor ring are of the PCI command type Memory Read (type 6). Burst read accesses to the transmit buffer typically are longer than two data phases. When MEMCMD (BCR18, bit 9) is cleared to 0, all burst read accesses to the transmit buffer are of the PCI command type Memory Read Line (type 14). When MEMCMD (BCR18, bit 9) is set to 1, all burst read accesses to the transmit buffer are of the PCI command type Memory Read Multiple (type 12).

AD[1:0] will both be 0 during the address phase indicating a linear burst order. Note that during a burst read operation, all byte lanes will always be active. The Am79C978A controller will internally discard unneeded bytes.

The Am79C978A controller will always perform only a single burst read transaction per bus mastership period, where *transaction* is defined as one address phase and one or multiple data phases. The Am79C978A controller supports zero wait state read cycles. It asserts $\overline{\text{IRDY}}$ immediately after the address phase and at the same time starts sampling $\overline{\text{DEVSEL}}$. $\overline{\text{FRAME}}$ is deasserted when the next to last data phase is completed.

Figure 15 shows a typical burst read access. The Am79C978A controller arbitrates for the bus, is granted access, reads three 32-bit words (DWord) from the system memory, and then releases the bus. In the example, the memory system extends the data phase of each access by one wait state. The example assumes that EXTREQ (BCR18, bit 8) is cleared to 0, therefore, $\overline{\text{REQ}}$ is deasserted in the same cycle as $\overline{\text{FRAME}}$ is asserted.

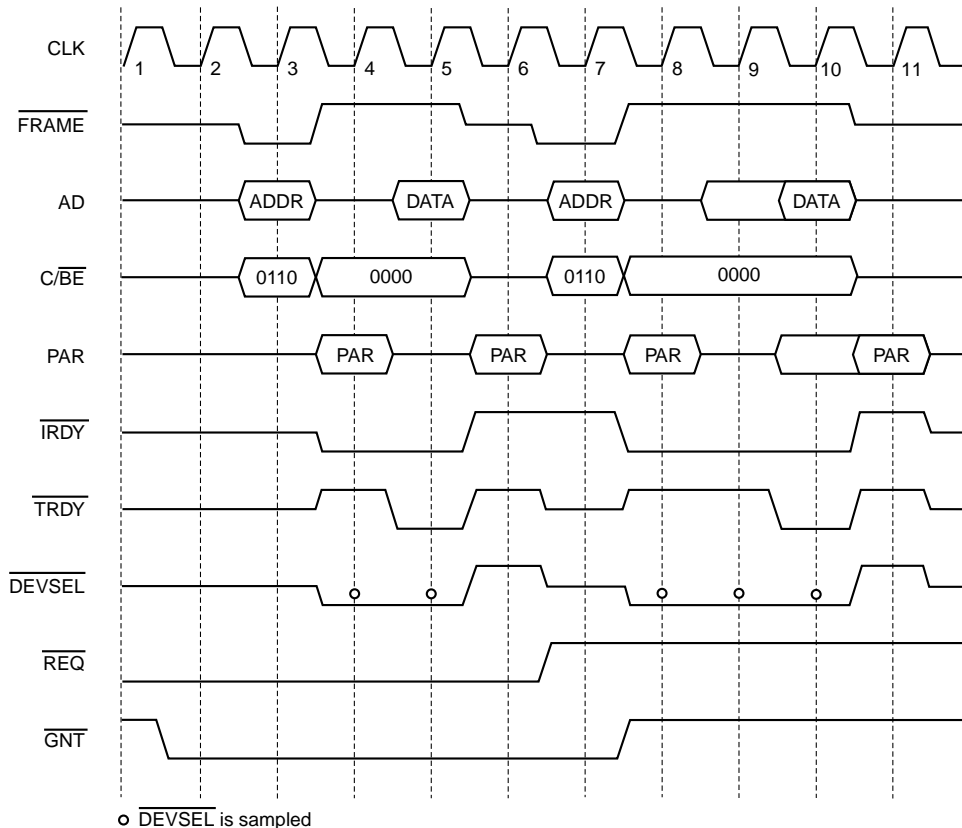

22399A-17

Figure 14. Non-Burst Read Transfer

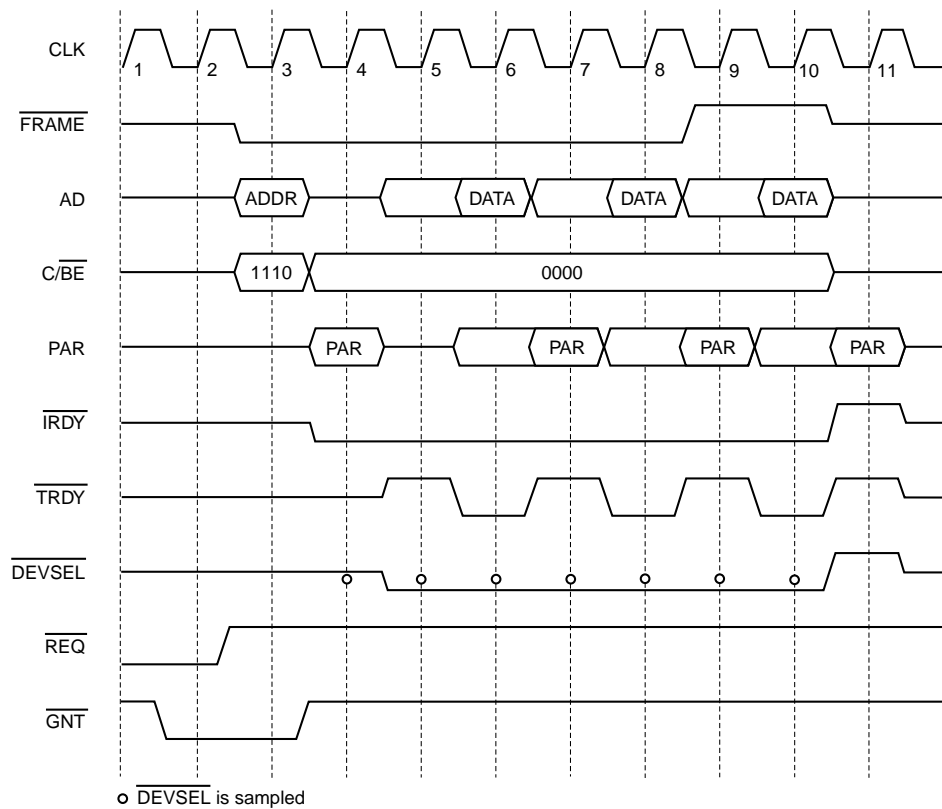

22399A-18

Figure 15. Burst Read Transfer (EXTREQ = 0, MEMCMD = 0)

Basic Non-Burst Write Transfer

By default, the Am79C978A controller uses non-burst cycles in all bus master write operations. All controller non-burst write accesses are of the PCI command type Memory Write (type 7). The byte enable signals indicate the byte lanes that have valid data. The Am79C978A controller typically performs more than one non-burst write transaction within a single bus mastership period. FRAME is dropped between consecutive non-burst write cycles. REQ stays asserted until FRAME is asserted for the last transaction. The Am79C978A controller supports zero wait state write cycles except with descriptor write transfers. (See the *Descriptor DMA Transfers* section for the only exception.) It asserts IRDY immediately after the address phase.

Figure 16 shows two non-burst write transactions. The first transaction has two wait states. The target inserts one wait state by asserting DEVSEL one clock late and another wait state by also asserting TRDY one clock late. The second transaction shows a zero wait state write cycle. The target asserts DEVSEL and TRDY in the same cycle as the Am79C978A controller asserts IRDY.

Basic Burst Write Transfer

The Am79C978A controller supports burst mode for all bus master write operations. The burst mode must be enabled by setting BWRITE (BCR18, bit 5). To allow burst transfers in descriptor write operations, the Am79C978A controller must also be programmed to use SWSTYLE 3 (BCR20, bits 7-0). All controller burst write transfers are of the PCI command type Memory Write (type 7). AD[1:0] will both be 0 during the address phase indicating a linear burst order. The byte enable signals indicate the byte lanes that have valid data.

The Am79C978A controller will always perform a single burst write transaction per bus mastership period, where transaction is defined as one address phase and one or multiple data phases. The Am79C978A controller supports zero wait state write cycles except with the case of descriptor write transfers. (See the *Descriptor DMA Transfers* section for the only exception.) The device asserts IRDY immediately after the address phase and at the same time starts sampling DEVSEL. FRAME is deasserted when the next to last data phase is completed.

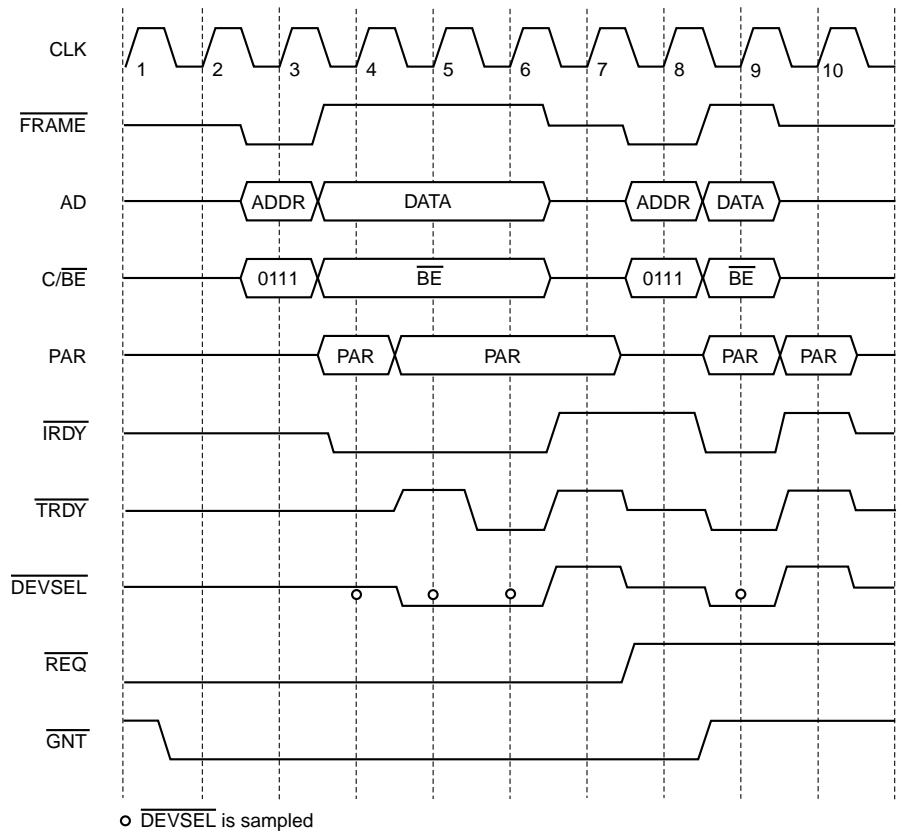

22399A-19

Figure 16. Non-Burst Write Transfer

Figure 17 shows a typical burst write access. The Am79C978A controller arbitrates for the bus, is granted access, and writes four 32-bit words (DWords) to the system memory and then releases the bus. In this example, the memory system extends the data phase of the first access by one wait state. The following three data phases take one clock cycle each, which is determined by the timing of $\overline{\text{TRDY}}$. The example assumes that EXTREQ (BCR18, bit 8) is set to 1, therefore, $\overline{\text{REQ}}$ is not deasserted until the next to last data phase is finished.

Target Initiated Termination

When the Am79C978A controller is a bus master, the cycles it produces on the PCI bus may be terminated by the target in one of three different ways: disconnect

with data transfer, disconnect without data transfer, and target abort.

Disconnect With Data Transfer

Figure 18 shows a disconnection in which one last data transfer occurs after the target asserted $\overline{\text{STOP}}$. $\overline{\text{STOP}}$ is asserted on clock 4 to start the termination sequence. Data is still transferred during this cycle, since both $\overline{\text{IRDY}}$ and $\overline{\text{TRDY}}$ are asserted. The Am79C978A controller terminates the current transfer with the deassertion of $\overline{\text{FRAME}}$ on clock 5 and of $\overline{\text{IRDY}}$ one clock later. It finally releases the bus on clock 7. If it wants to transfer more data, the Am79C978A controller will again request the bus after two clock cycles. The starting address of the new transfer will be the address of the next non-transferred data.

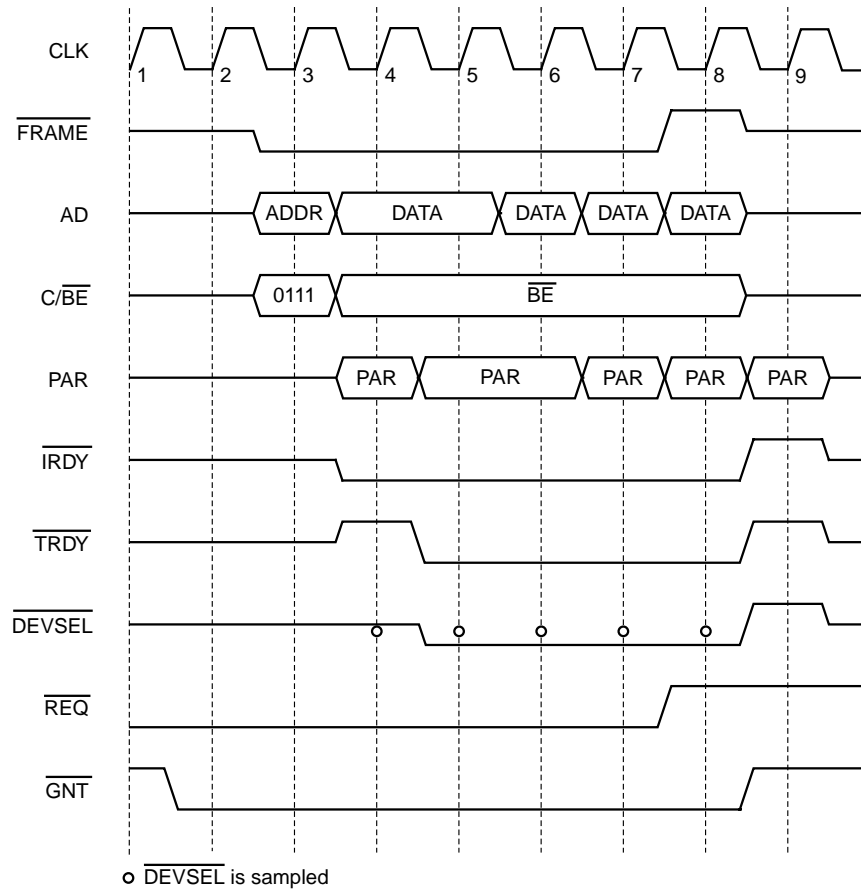

22399A-20

Figure 17. Burst Write Transfer (EXTREQ = 1)

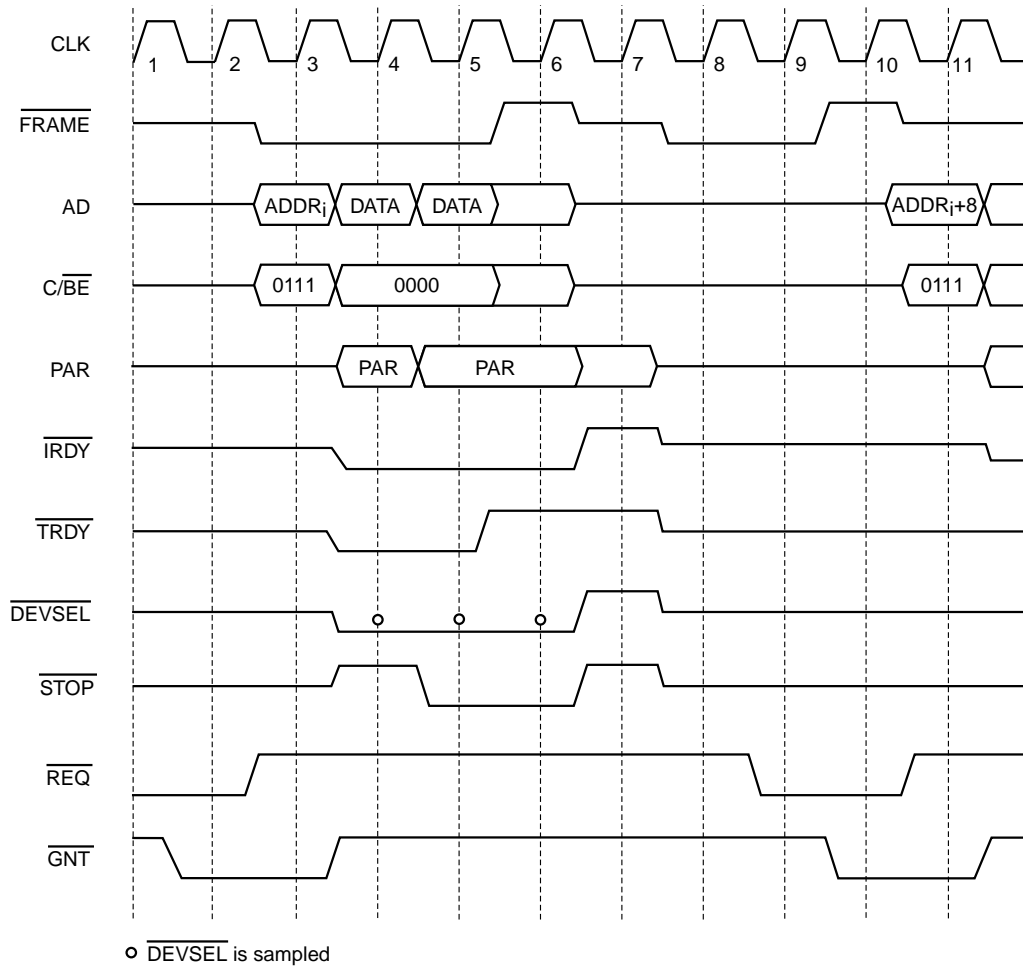

22399A-21

Figure 18. Disconnect With Data Transfer

Disconnect Without Data Transfer

Figure 19 shows a target disconnect sequence during which no data is transferred. \overline{STOP} is asserted on clock 4 without \overline{TRDY} being asserted at the same time. The Am79C978A controller terminates the access with the deassertion of \overline{FRAME} on clock 5 and of \overline{IRDY} one clock cycle later. It finally releases the bus on clock 7. The Am79C978A controller will again request the bus after two clock cycles to retry the last transfer. The starting address of the new transfer will be the address of the last non-transferred data.

Target Abort

Figure 20 shows a target abort sequence. The target asserts \overline{DEVSEL} for one clock. It then deasserts \overline{DEVSEL} and asserts \overline{STOP} on clock 4. A target can use the target abort sequence to indicate that it cannot service the data transfer and that it does not want the transaction to be retried. Additionally, the Am79C978A controller cannot make any assumption

about the success of the previous data transfers in the current transaction. The Am79C978A controller terminates the current transfer with the deassertion of \overline{FRAME} on clock 5 and of \overline{IRDY} one clock cycle later. It finally releases the bus on clock 6.

Since data integrity is not guaranteed, the Am79C978A controller cannot recover from a target abort event. The Am79C978A controller will reset all CSR locations to their $\overline{STOP_RESET}$ values. The BCR and PCI configuration registers will not be cleared. Any on-going network transmission is terminated in an orderly sequence. If less than 512 bits have been transmitted immediately, generating a runt packet. If 512 bits or more have been transmitted, the message will have the current FCS inverted and appended at the next byte boundary to guarantee an FCS error is detected at the receiving station.

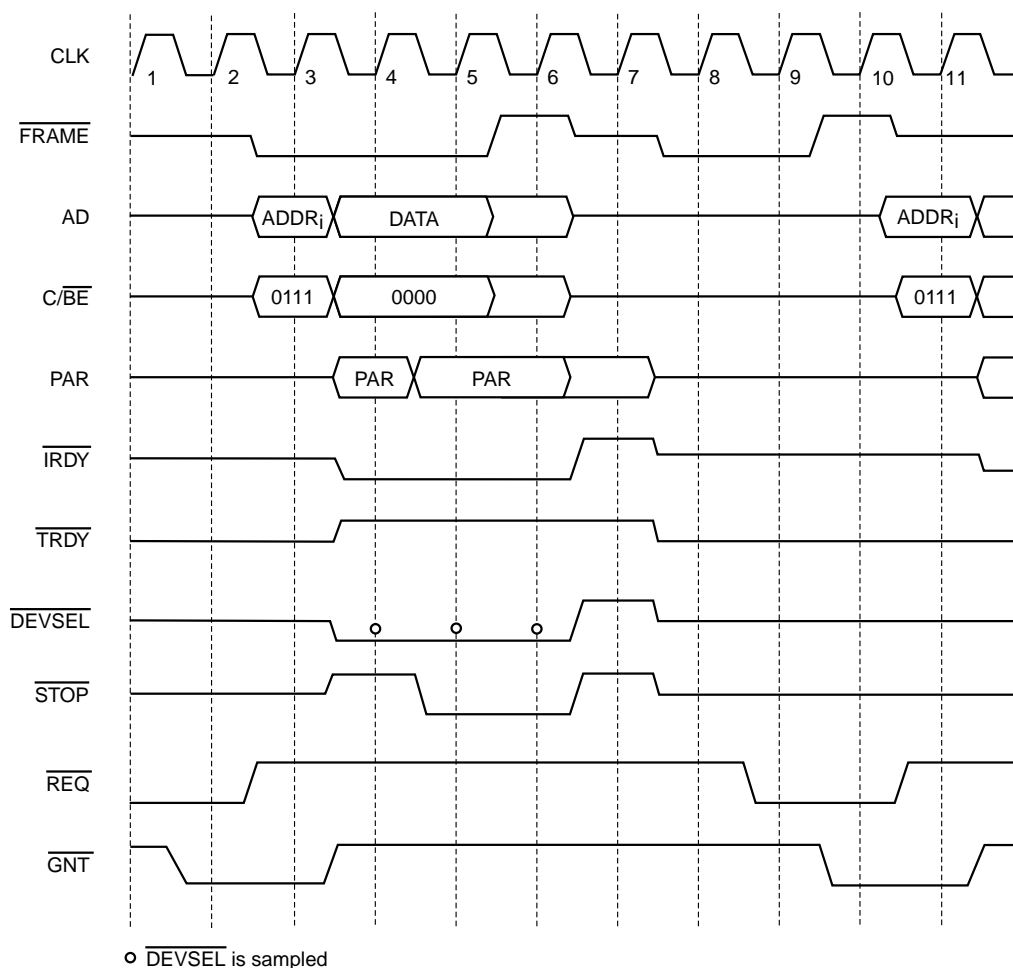

Figure 19. Disconnect Without Data Transfer

RTABORT (PCI Status register, bit 12) will be set to indicate that the Am79C978A controller has received a target abort. In addition, SINT (CSR5, bit 11) will be set to 1. When SINT is set, INTA is asserted if the enable bit SINTE (CSR5, bit 10) is set to 1. This mechanism can be used to inform the driver of the system error. The host can read the PCI Status register to determine the exact cause of the interrupt.

Master Initiated Termination

There are three scenarios besides normal completion of a transaction where the Am79C978A controller will terminate the cycles it produces on the PCI bus.

Preemption During Non-Burst Transaction

When the Am79C978A controller performs multiple non-burst transactions, it keeps REQ asserted until the assertion of FRAME for the last transaction. When GNT is removed, the Am79C978A controller will finish the current transaction and then release the bus. If it is not the last transaction,

REQ will remain asserted to regain bus ownership as soon as possible. See Figure 21.

Preemption During Burst Transaction

When the Am79C978A controller operates in burst mode, it only performs a single transaction per bus mastership period, where *transaction* is defined as one address phase and one or multiple data phases. The central arbiter can remove GNT at any time during the transaction. The Am79C978A controller will ignore the deassertion of GNT and continue with data transfers, as long as the PCI Latency Timer is not expired. When the Latency Timer is 0 and GNT is deasserted, the Am79C978A controller will finish the current data phase, deassert FRAME, finish the last data phase, and release the bus. If EXTREQ (BCR18, bit 8) is cleared to 0, it will immediately assert REQ to regain bus ownership as soon as possible. If EXTREQ is set to 1, REQ will stay asserted.

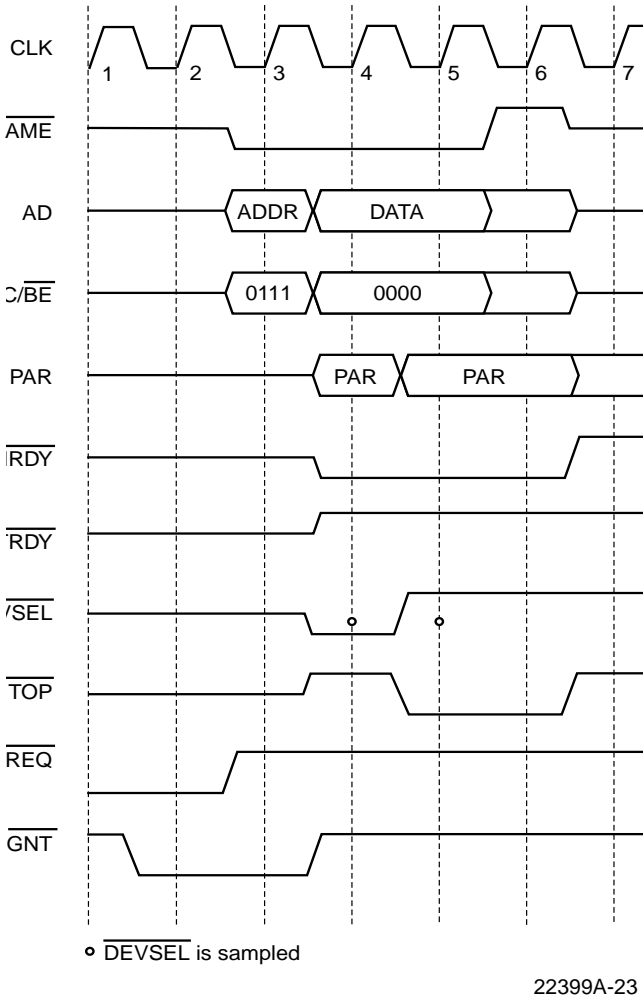

Figure 20. Target Abort

When the preemption occurs after the counter has counted down to 0, the Am79C978A controller will finish the current data phase, deassert $\overline{\text{FRAME}}$, finish the last data phase, and release the bus. Note that it is important for the host to program the PCI Latency Timer according to the bus bandwidth requirement of the Am79C978A controller. The host can determine this bus bandwidth requirement by reading the PCI MAX_LAT and MIN_GNT registers.

Figure 22 assumes that the PCI Latency Timer has counted down to 0 on clock 7.

Master Abort

The Am79C978A controller will terminate its cycle with a Master Abort sequence if DEVSEL is not asserted within 4 clocks after FRAME is asserted. Master Abort is treated as a fatal error by the Am79C978A controller.

The Am79C978A controller will reset all CSR locations to their STOP_RESET values. The BCR and PCI configuration registers will not be cleared. Any on-going network transmission is terminated in an orderly sequence. If less than 512 bits have been transmitted onto the network, the transmission will be terminated immediately, generating a runt packet. If 512 bits or more have been transmitted, the message will have the current FCS inverted and appended at the next byte boundary to guarantee an FCS error is detected at the receiving station.

RMABORT (in the PCI Status register, bit 13) will be set to indicate that the Am79C978A controller has terminated its transaction with a master abort. In addition, SINT (CSR5, bit 11) will be set to 1. When SINT is set, INTA is asserted if the enable bit SINTE (CSR5, bit 10) is set to 1. This mechanism can be used to inform the driver of the system error. The host can read the PCI Status register to determine the exact cause of the interrupt. See Figure 23.

Parity Error Response

During every data phase of a DMA read operation, when the target indicates that the data is valid by asserting $\overline{\text{TRDY}}$, the Am79C978A controller samples the AD[31:0], C/BE[3:0], and the PAR lines for a data parity error. When it detects a data parity error, the Am79C978A controller sets PERR (PCI Status register, bit 15) to 1. When reporting of that error is enabled by setting PERREN (PCI Command register, bit 6) to 1, the Am79C978A controller also drives the $\overline{\text{PERR}}$ signal low and sets DATAPERR (PCI Status register, bit 8) to 1. The assertion of $\overline{\text{PERR}}$ follows the corrupted data/byte enables by two clock cycles and PAR by one clock cycle.

Figure 24 shows a transaction that has a parity error in the data phase. The Am79C978A controller asserts $\overline{\text{PERR}}$ on clock 8, two clock cycles after data is valid. The data on clock 5 is not checked for parity, because on a read access, PAR is only required to be valid one clock after the target has asserted $\overline{\text{TRDY}}$. The Am79C978A controller then drives $\overline{\text{PERR}}$ high for one clock cycle, since $\overline{\text{PERR}}$ is a sustained tri-state signal.

During every data phase of a DMA write operation, the Am79C978A controller checks the $\overline{\text{PERR}}$ input to see if the target reports a parity error. When it sees the $\overline{\text{PERR}}$ input asserted, the Am79C978A controller sets PERR (PCI Status register, bit 15) to 1. When PERREN (PCI Command register, bit 6) is set to 1, the Am79C978A controller also sets DATAPERR (PCI Status register, bit 8) to 1.

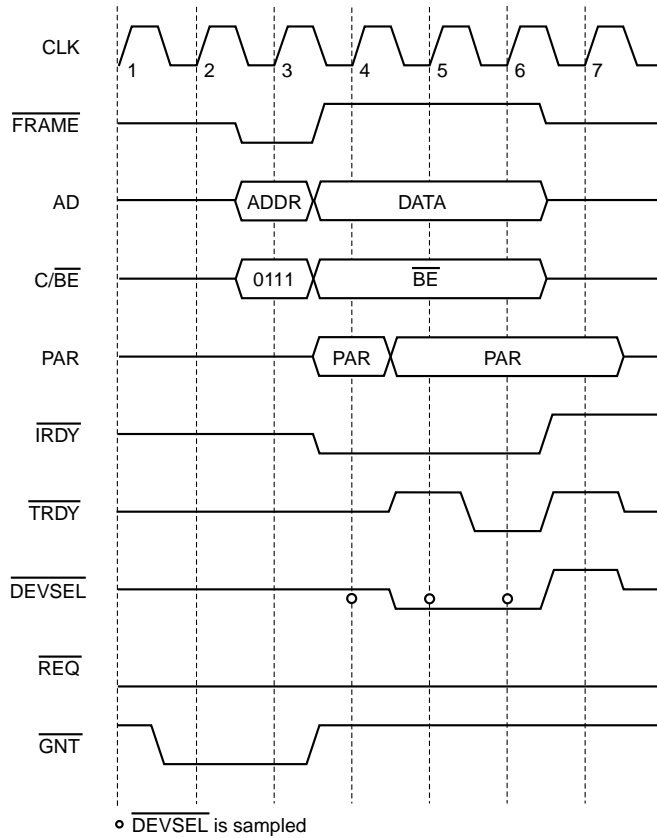

22399A-24

Figure 21. Preemption During Non-Burst Transaction

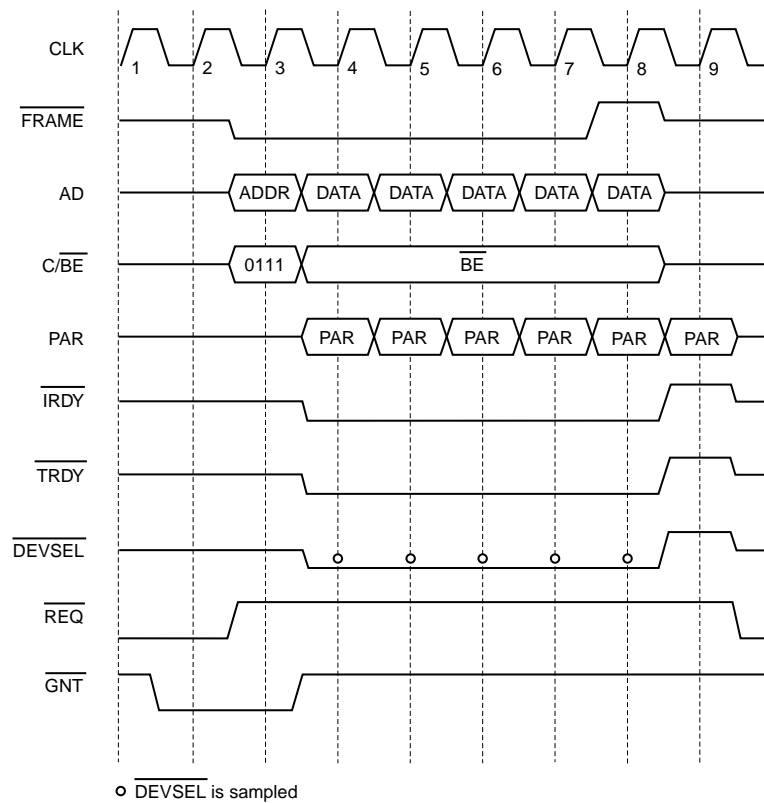

22399A-25

Figure 22. Preemption During Burst Transaction

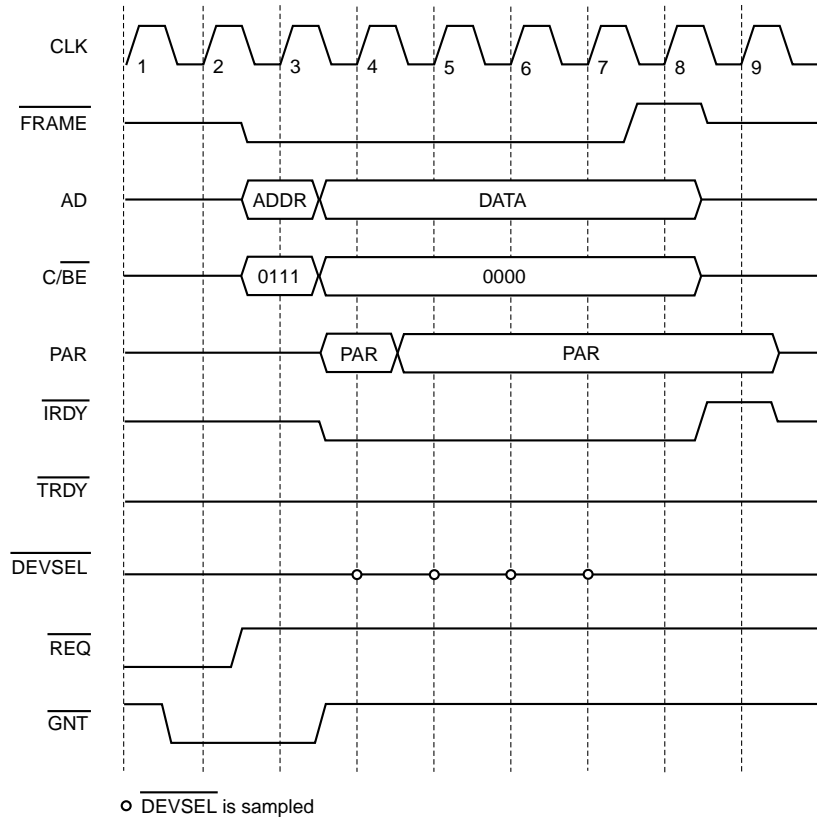

22399A-26

Figure 23. Master Abort

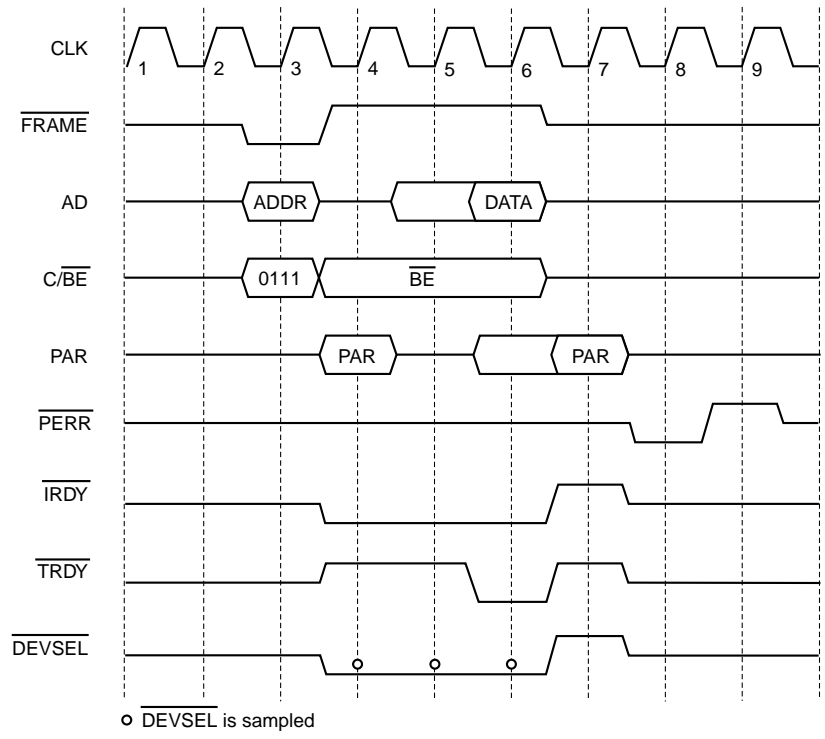

22399A-27

Figure 24. Master Cycle Data Parity Error Response

Whenever the Am79C978A controller is the current bus master and a data parity error occurs, SINT (CSR5, bit 11) will be set to 1. When SINT is set, $\overline{\text{INTA}}$ is asserted if the enable bit SINTE (CSR5, bit 10) is set to 1. This mechanism can be used to inform the driver of the system error. The host can read the PCI Status register to determine the exact cause of the interrupt. The setting of SINT due to a data parity error is not dependent on the setting of PERREN (PCI Command register, bit 6).

By default, a data parity error does not affect the state of the MAC engine. The Am79C978A controller treats the data in all bus master transfers that have a parity error as if nothing has happened. All network activity continues.

Advanced Parity Error Handling

For all DMA cycles, the Am79C978A controller provides a second, more advanced level of parity error handling. This mode is enabled by setting APERREN (BCR20, bit 10) to 1. When APERREN is set to 1, the BPE bits (RMD1 and TMD1, bit 23) are used to indicate parity error in data transfers to the receive and transmit buffers. Note that since the advanced parity error handling uses an additional bit in the descriptor, SWSTYLE (BCR20, bits 7-0) must be set to 2 or 3 to program the Am79C978A controller to use 32-bit software structures. The Am79C978A controller will react in the following way when a data parity error occurs:

- Initialization block read: STOP (CSR0, bit 2) is set to 1 and causes a STOP_RESET of the device.
- Descriptor ring read: Any on-going network activity is terminated in an orderly sequence and then STOP (CSR0, bit 2) is set to 1 to cause a STOP_RESET of the device.
- Descriptor ring write: Any on-going network activity is terminated in an orderly sequence and then STOP (CSR0, bit 2) is set to 1 to cause a STOP_RESET of the device.
- Transmit buffer read: BPE (TMD1, bit 23) is set in the current transmit descriptor. Any on-going network transmission is terminated in an orderly sequence.
- Receive buffer write: BPE (RMD1, bit 23) is set in the last receive descriptor associated with the frame.

Terminating on-going network transmission in an orderly sequence means that if less than 512 bits have been transmitted onto the network, the

transmission will be terminated immediately, generating a runt packet.

If 512 bits or more have been transmitted, the message will have the current FCS inverted and appended at the next byte boundary to guarantee an FCS error is detected at the receiving station.

APERREN does not affect the reporting of address parity errors or data parity errors that occur when the Am79C978A controller is the target of the transfer.

Initialization Block DMA Transfers

During execution of the Am79C978A controller bus master initialization procedure, the microcode will repeatedly request DMA transfers from the BIU. During each of these initialization block DMA transfers, the BIU will perform two data transfer cycles reading one DWord per transfer and then it will relinquish the bus. When SSIZE32 (BCR20, bit 8) is set to 1 (i.e., the initialization block is organized as 32-bit software structures), there are seven DWords to transfer during the bus master initialization procedure, so four bus mastership periods are needed in order to complete the initialization sequence. Note that the last DWord transfer of the last bus mastership period of the initialization sequence accesses an unneeded location. Data from this transfer is discarded internally. When SSIZE32 is cleared to 0 (i.e., the initialization block is organized as 16-bit software structures), then three bus mastership periods are needed to complete the initialization sequence.

The Am79C978A device supports two transfer modes for reading the initialization block: non-burst and burst mode, with burst mode being the preferred mode when the Am79C978A controller is used in a PCI bus application. See Figure 25 and Figure 26.

When BREADE is cleared to 0 (BCR18, bit 6), all initialization block read transfers will be executed in non-burst mode. There is a new address phase for every data phase. $\overline{\text{FRAME}}$ will be dropped between the two transfers. The two phases within a bus mastership period will have addresses of ascending contiguous order.

When BREADE is set to 1 (BCR18, bit 6), all initialization block read transfers will be executed in burst mode. AD[1:0] will be 0 during the address phase indicating a linear burst order.

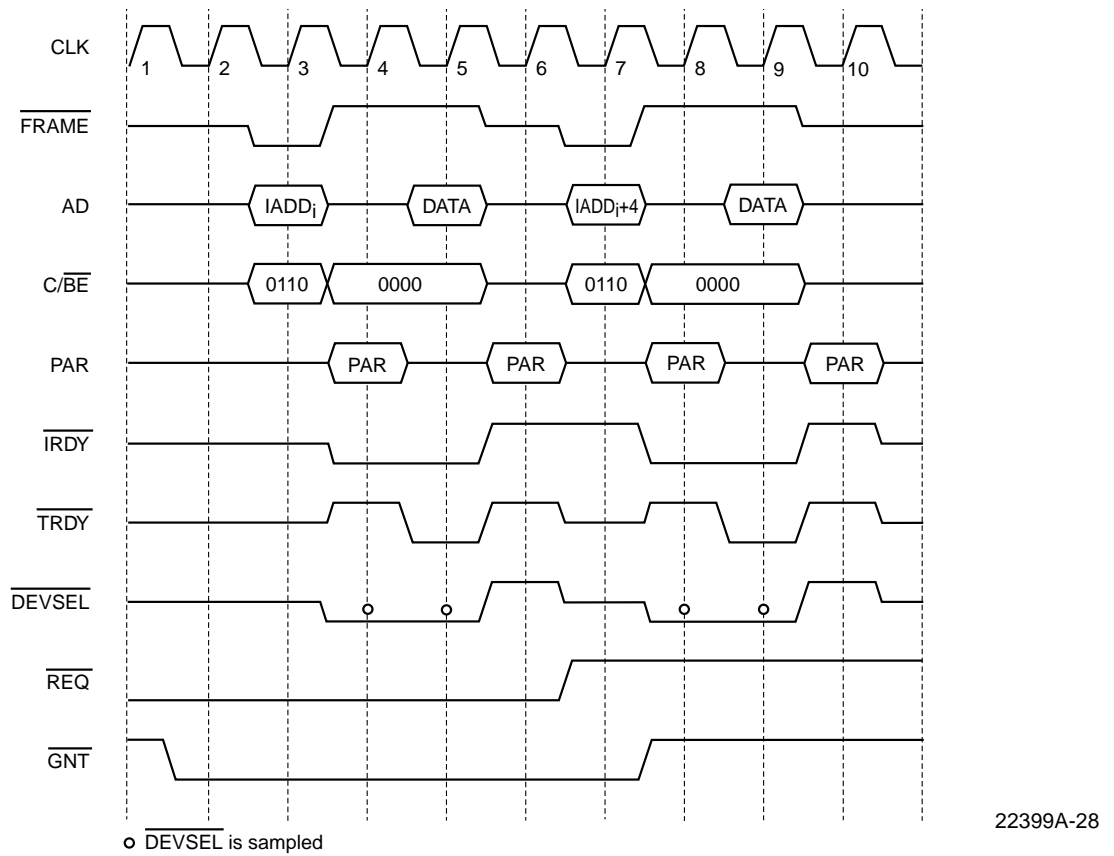

Figure 25. Initialization Block Read In Non-Burst Mode

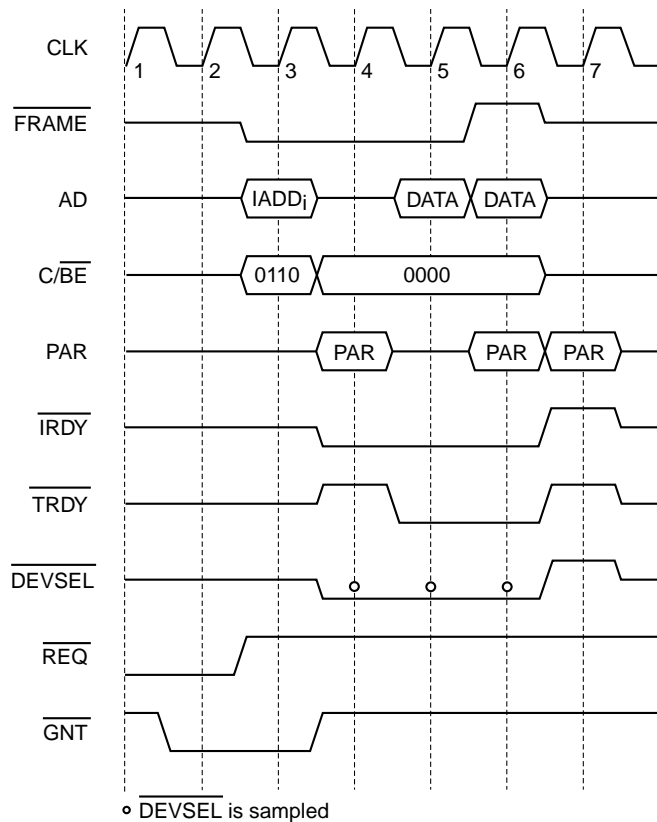

Figure 26. Initialization Block Read In Burst Mode

Descriptor DMA Transfers

The Am79C978A microcode will determine when a descriptor access is required. A descriptor DMA read will consist of two data transfers. A descriptor DMA write will consist of one or two data transfers. The descriptor DMA transfers within a single bus mastership period will always be of the same type (either all read or all write).

During descriptor read accesses, the byte enable signals will indicate that all byte lanes are active. Should some of the bytes not be needed, then the Am79C978A controller will internally discard the extraneous information that was gathered during such a read.

The settings of SWSTYLE (BCR20, bits 7-0) and BREADE (BCR18, bit 6) affect the way the Am79C978A controller performs descriptor read operations.

When SWSTYLE is set to 0 or 2, all descriptor read operations are performed in non-burst mode. The setting of BREADE has no effect in this configuration. See Figure 27.

When SWSTYLE is set to 3, the descriptor entries are ordered to allow burst transfers. The Am79C978A controller will perform all descriptor read operations in burst mode, if BREADE is set to 1. See Figure 28.

Table 9 shows the descriptor read sequence.

During descriptor write accesses, only the byte lanes which need to be written are enabled.

If buffer chaining is used, accesses to the descriptors of all intermediate buffers consist of only one data transfer to return ownership of the buffer to the system. When SWSTYLE (BCR20, bits 7-0) is cleared to 0 (i.e., the descriptor entries are organized as 16-bit software structures), the descriptor access will write a single byte. When SWSTYLE (BCR20, bits 7-0) is set to 2 or 3 (i.e., the descriptor entries are organized as 32-bit software structures), the descriptor access will write a single word. On all single buffer transmit or receive descriptors, as well as on the last buffer in chain, writes to the descriptor consist of two data transfers.

The first data transfer writes a DWord containing status information. The second data transfer writes a byte (SWSTYLE cleared to 0), or otherwise a word containing additional status and the ownership bit (i.e., MD1[31]).

The settings of SWSTYLE (BCR20, bits 7-0) and BWRITE (BCR18, bit 5) affect the way the Am79C978A controller performs descriptor write operations.

When SWSTYLE is set to 0 or 2, all descriptor write operations are performed in non-burst mode. The

setting of BWRITE has no effect in this configuration. See Figure 29.

When SWSTYLE is set to 3, the descriptor entries are ordered to allow burst transfers. The Am79C978A controller will perform all descriptor write operations in burst mode, if BWRITE is set to 1. See Figure 30 and Table 10 for the descriptor write sequence.

A write transaction to the descriptor ring entries is the only case where the Am79C978A controller inserts a wait state when being the bus master. Every data phase in non-burst and burst mode is extended by one clock cycle, during which \overline{IRDY} is deasserted.

Note that Figure 28 assumes that the Am79C978A controller is programmed to use 32-bit software structures (SWSTYLE = 2 or 3). The byte enable signals for the second data transfer would be 0111b, if the device was programmed to use 16-bit software structures (SWSTYLE = 0).

Table 9. Descriptor Read Sequence

SWSTYLE BCR20[7:0]	BREADE BCR18[6]	AD Bus Sequence
0	X	Address = XXXX XX00h Turn around cycle Data = MD1[31:24], MD0[23:0] Idle Address = XXXX XX04h Turn around cycle Data = MD2[15:0], MD1[15:0]
2	X	Address = XXXX XX04h Turn around cycle Data = MD1[31:0] Idle Address = XXXX XX00h Turn around cycle Data = MD0[31:0]
3	0	Address = XXXX XX04h Turn around cycle Data = MD1[31:0] Idle Address = XXXX XX08h Turn around cycle Data = MD0[31:0]
3	1	Address = XXXX XX04h Turn around cycle Data = MD1[31:0] Data = MD0[31:0]

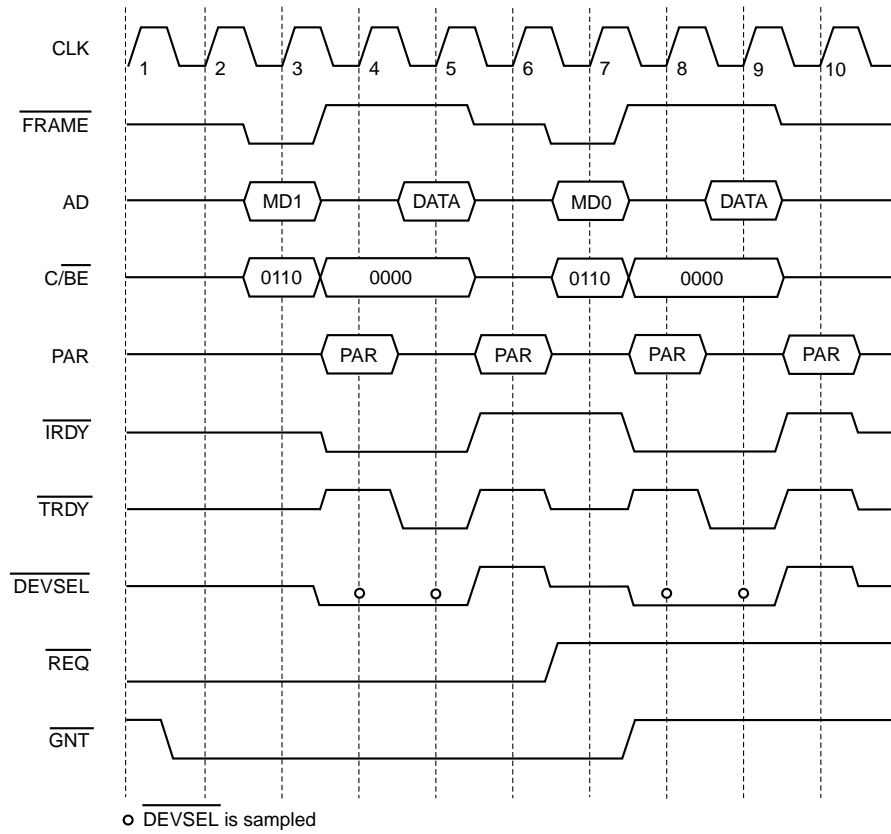

22399A-30

Figure 27. Descriptor Ring Read In Non-Burst Mode

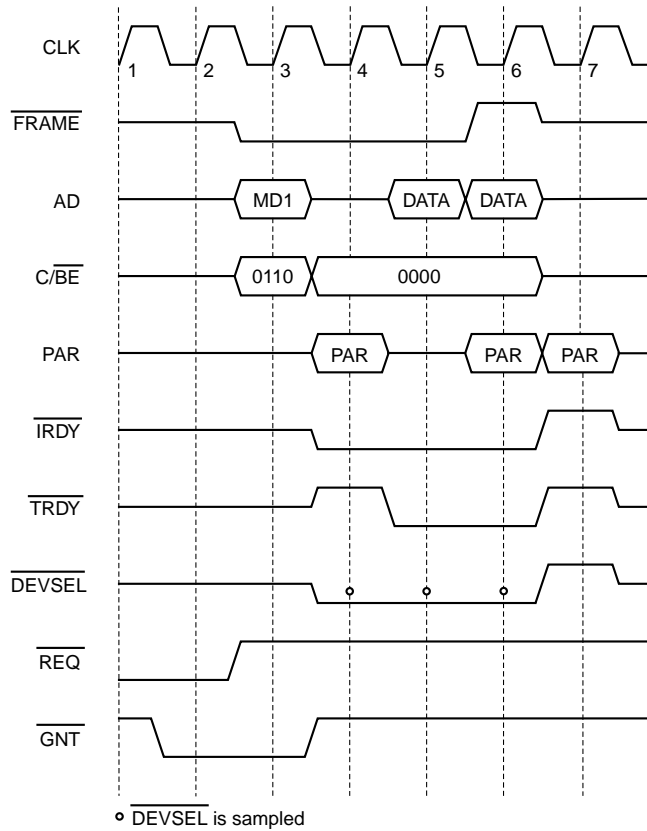

22399A-31

Figure 28. Descriptor Ring Read In Burst Mode

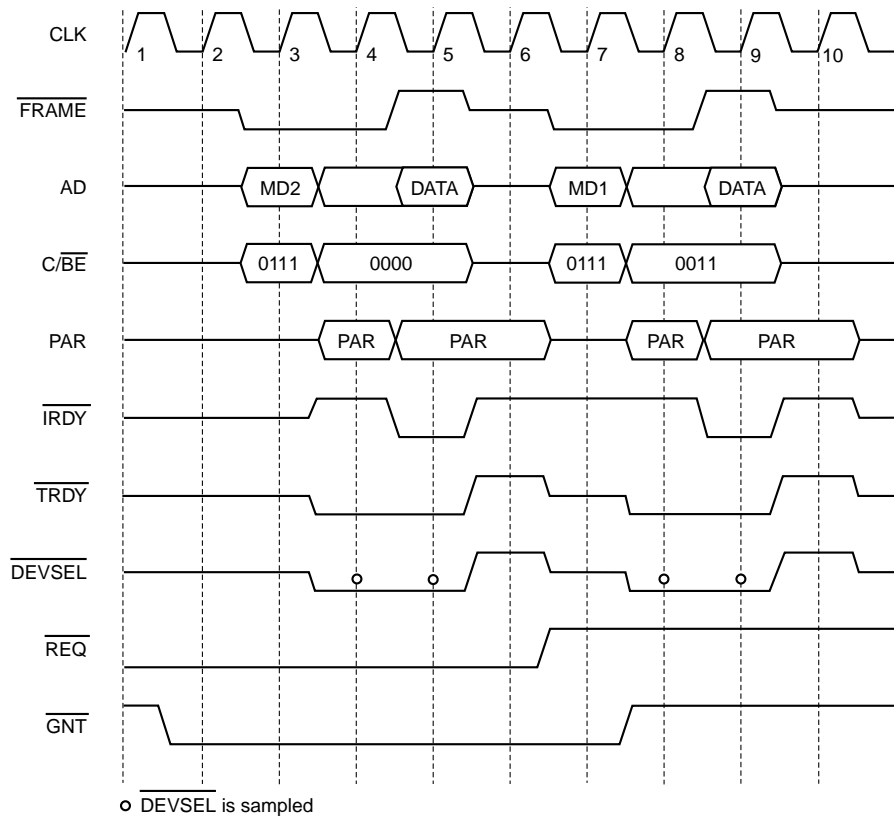

22399A-32

Figure 29. Descriptor Ring Write In Non-Burst Mode

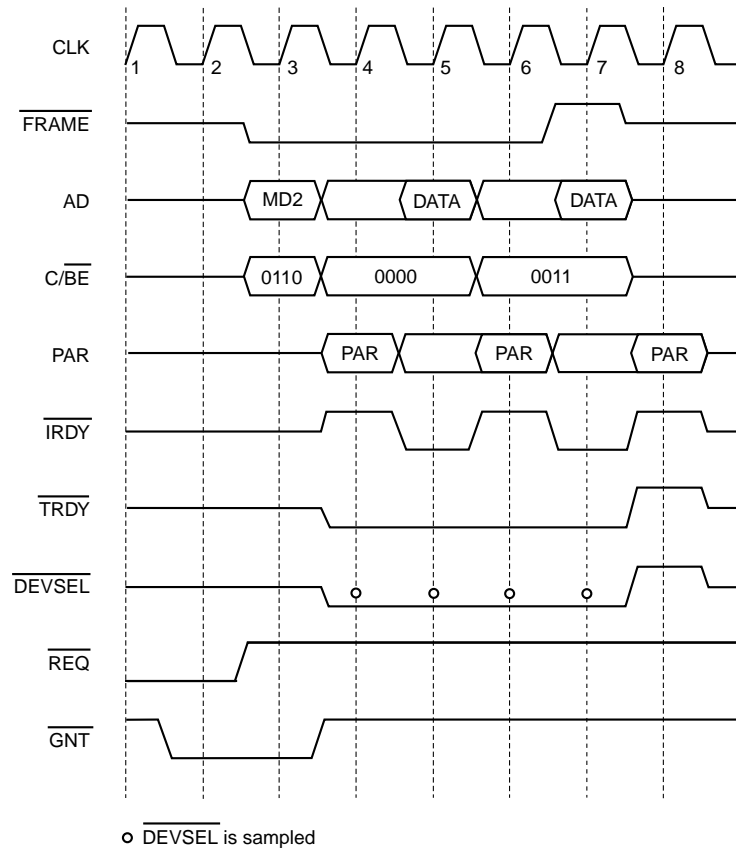

22399A-33

Figure 30. Descriptor Ring Write In Burst Mode

Table 10. Descriptor Write Sequence

SWSTYLE BCR20[7:0]	BWRITE BCR18[5]	AD Bus Sequence
0	X	Address = XXXX XX04h Data = MD2[15:0], MD1[15:0] Idle Address = XXXX XX00h Data = MD1[31:24]
2	X	Address = XXXX XX08h Data = MD2[31:0] Idle Address = XXXX XX04h Data = MD1[31:16]
3	0	Address = XXXX XX00h Data = MD2[31:0] Idle Address = XXXX XX04h Data = MD1[31:16]
3	1	Address = XXXX XX00h Data = MD2[31:0] Data = MD1[31:16]

FIFO DMA Transfers

The Am79C978A microcode will determine when a FIFO DMA transfer is required. This transfer mode will be used for transfers of data to and from the FIFOs. Once the BIU has been granted bus mastership, it will perform a series of consecutive transfer cycles before relinquishing the bus. All transfers within the master cycle will be either read or write cycles, and all transfers will be to contiguous, ascending addresses. Both non-burst and burst cycles are used, with burst mode being the preferred mode when the device is used in a PCI bus application.

Non-Burst FIFO DMA Transfers

In the default mode, the Am79C978A controller uses non-burst transfers to read and write data when accessing the FIFOs. Each non-burst transfer will be performed sequentially with the issue of an address and the transfer of the corresponding data with appropriate output signals to indicate selection of the active data bytes during the transfer.

$\overline{\text{FRAME}}$ will be deasserted after every address phase. Several factors will affect the length of the bus mastership period. The possibilities are as follows:

Bus cycles will continue until the transmit FIFO is filled to its high threshold (read transfers) or the receive FIFO is emptied to its low threshold (write transfers). The exact number of total transfer cycles in the bus

mastership period is dependent on all of the following variables: the settings of the FIFO watermarks, the conditions of the FIFOs, the latency of the system bus to the Am79C978A controller’s bus request, the speed of bus operation and bus preemption events. The $\overline{\text{TRDY}}$ response time of the memory device will also affect the number of transfers, since the speed of the accesses will affect the state of the FIFO. During accesses, the FIFO may be filling or emptying on the network end. For example, on a receive operation, a slower $\overline{\text{TRDY}}$ response will allow additional data to accumulate inside of the FIFO. If the accesses are slow enough, a complete DWord may become available before the end of the bus mastership period and, thereby, increase the number of transfers in that period. The general rule is that the longer the Bus Grant latency, the slower the bus transfer operations; the slower the clock speed, the higher the transmit watermark; or the higher the receive watermark, the longer the bus mastership period will be.

Note: *The PCI Latency Timer is not significant during non-burst transfers.*

Burst FIFO DMA Transfers

Bursting is only performed by the Am79C978A controller if the BREADE and/or BWRITE bits of BCR18 are set. These bits individually enable/disable the ability of the Am79C978A controller to perform burst accesses during master read operations and master write operations, respectively.

A burst transaction will start with an address phase, followed by one or more data phases. AD[1:0] will always be 0 during the address phase indicating a linear burst order.

During FIFO DMA read operations, all byte lanes will always be active. The Am79C978A controller will internally discard unused bytes. During the first and the last data phases of a FIFO DMA burst write operation, one or more of the byte enable signals may be inactive. All other data phases will always write a complete DWord.

Figure 31 shows the beginning of a FIFO DMA write with the beginning of the buffer not aligned to a DWord boundary. The Am79C978A controller starts off by writing only three bytes during the first data phase. This operation aligns the address for all other data transfers to a 32-bit boundary so that the Am79C978A controller can continue bursting full DWords.

If a receive buffer does not end on a DWord boundary, the Am79C978A controller will perform a non-DWord write on the last transfer to the buffer. Figure 32 shows the final three FIFO DMA transfers to a receive buffer. Since there were only nine bytes of space left in the receive buffer, the Am79C978A controller bursts three data phases. The first two data phases write a full DWord, the last one only writes a single byte.

Note that the Am79C978A controller will always perform a DWord transfer as long as it owns the buffer space, even when there are less than four bytes to write. For example, if there is only one byte left for the current receive frame, the Am79C978A controller will write a full DWord, containing the last byte of the receive frame in the least significant byte position (BSWP is cleared to 0, CSR3, bit 2). The content of the other three bytes is undefined. The message byte count in the receive descriptor always reflects the exact length of the received frame.

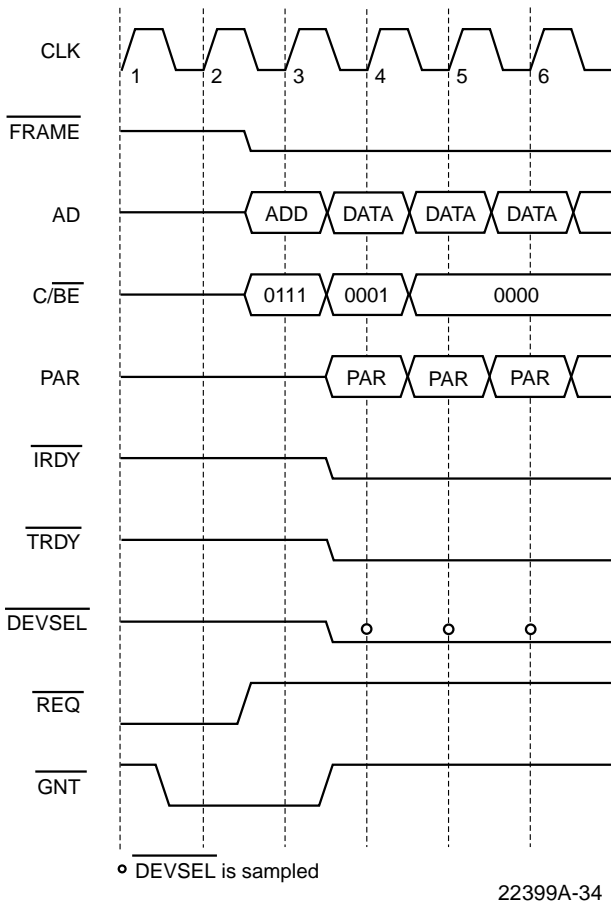
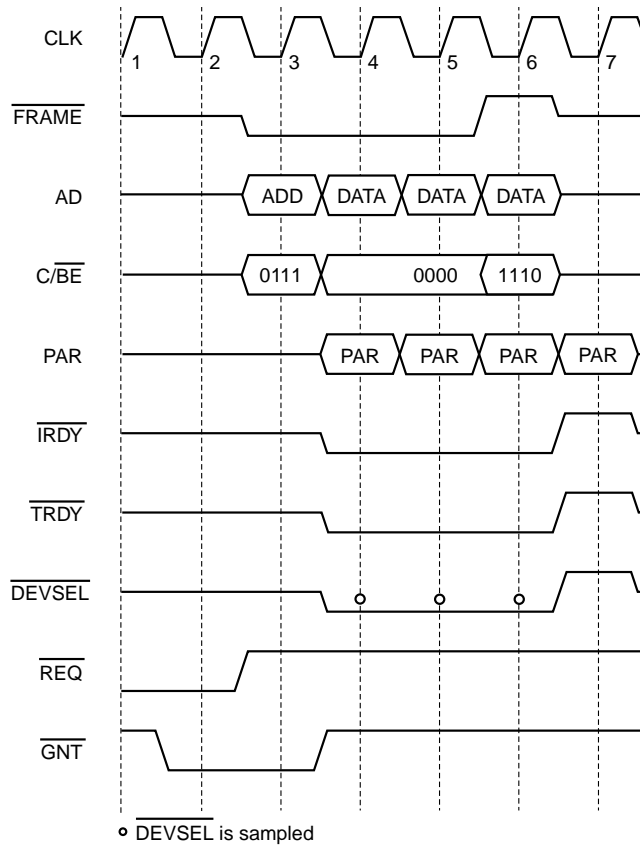

Figure 31. FIFO Burst Write at Start of Unaligned Buffer

The Am79C978A controller will continue transferring FIFO data until the transmit FIFO is filled to its high threshold (read transfers) or the receive FIFO is emptied to its low threshold (write transfers), or the Am79C978A controller is preempted and the PCI Latency Timer is expired. The host should use the values in the PCI MIN_GNT and MAX_LAT registers to determine the value for the PCI Latency Timer.



22399A-35

Figure 32. FIFO Burst Write at End of Unaligned Buffer

The exact number of total transfer cycles in the bus mastership period is dependent on all of the following variables: the settings of the FIFO watermarks, the conditions of the FIFOs, the latency of the system bus to the Am79C978A controller's bus request, and the speed of bus operation. The TRDY response time of the memory device will also affect the number of transfers, since the speed of the accesses will affect the state of the FIFO. During accesses, the FIFO may be filling or emptying on the network end. For example, on a receive operation, a slower TRDY response will allow additional data to accumulate inside of the FIFO. If the accesses are slow enough, a complete DWord may become available before the end of the bus mastership period and, thereby, increase the number of transfers in that period. The general rule is that the longer the Bus Grant latency, the slower the bus transfer operations; the slower the clock speed, the higher the transmit watermark; or the lower the receive watermark, the longer the total burst length will be.

When a FIFO DMA burst operation is preempted, the Am79C978A controller will not relinquish bus ownership until the PCI Latency Timer expires.

Buffer Management Unit

The Buffer Management Unit (BMU) is a microcoded state machine which implements the initialization procedure and manages the descriptors and buffers. The buffer management unit operates at half the speed of the CLK input.

Initialization

Initialization includes the reading of the initialization block in memory to obtain the operating parameters. The initialization block can be organized in two ways. When SSIZE32 (BCR20, bit 8) is at its default value of 0, all initialization block entries are logically 16-bits wide to be backwards compatible with the Am79C90 C-LANCE and Am79C96x PCnet-ISA family. When SSIZE32 (BCR20, bit 8) is set to 1, all initialization block entries are logically 32-bits wide. Note that the Am79C978A controller always performs 32-bit bus transfers to read the initialization block entries. The initialization block is read when the INIT bit in CSR0 is set. The INIT bit should be set before or concurrent with the STRT bit to insure correct operation. Once the initialization block has been completely read in and internal registers have been updated, IDON will be set in CSR0, generating an interrupt (if IENA is set).

The Am79C978A controller obtains the start address of the initialization block from the contents of CSR1 (least significant 16 bits of address) and CSR2 (most significant 16 bits of address). The host must write CSR1 and CSR2 before setting the INIT bit. The initialization block contains the user defined conditions for operation, together with the base addresses and length information of the transmit and receive descriptor rings.

There is an alternate method to initialize the Am79C978A controller. Instead of initialization via the initialization block in memory, data can be written directly into the appropriate registers. Either method or a combination of the two may be used at the discretion of the programmer. Refer to *Appendix A, Alternative Method for Initialization* for details on this alternate method.

Re-Initialization

The transmitter and receiver sections of the Am79C978A controller can be turned on via the initialization block (DTX, DRX, CSR15, bits 1-0). The states of the transmitter and receiver are monitored by the host through CSR0 (RXON, TXON bits). The Am79C978A controller should be re-initialized if the transmitter and/or the receiver were not turned on during the original initialization and it was subsequently required to activate them, or if either section was shut off due to the detection of an error condition (MERR, UFLO, TX BUFF error).

Re-initialization may be done via the initialization block or by setting the STOP bit in CSR0, followed by writing to CSR15, and then setting the START bit in CSR0. Note that this form of restart will not perform the same in the Am79C978A controller as in the C-LANCE device. In particular, upon restart, the Am79C978A controller reloads the transmit and receive descriptor pointers with their respective base addresses. This means that the software must clear the descriptor OWN bits and reset its descriptor ring pointers before restarting the Am79C978A controller. The reload of descriptor base addresses is performed in the C-LANCE device only after initialization, so that a restart of the C-LANCE without initialization leaves the C-LANCE pointing at the same descriptor locations as before the restart.

Suspend

The Am79C978A controller offers two suspend modes that allow easy updating of the CSR registers without going through a full re-initialization of the device. The suspend modes also allow stopping the device with orderly termination of all network activity.

The host requests the Am79C978A controller to enter the suspend mode by setting SPND (CSR5, bit 0) to 1. The host must poll SPND until it reads back 1 to determine that the Am79C978A controller has entered the suspend mode. When the host sets SPND to 1, the procedure taken by the Am79C978A controller to enter the suspend mode depends on the setting of the fast suspend enable bit (FASTSPND, CSR7, bit 15).

When a fast suspend is requested (FASTSPND is set to 1), the Am79C978A controller performs a quick entry into the suspend mode. At the time the SPND bit is set, the Am79C978A controller will continue the DMA process of any transmit and/or receive packets that have already begun DMA activity until the network activity has been completed. In addition, any transmit packet that had started transmission will be fully transmitted and any receive packet that had begun reception will be fully received. However, no additional packets will be transmitted or received and no additional transmit or receive DMA activity will begin after network activity has ceased. Hence, the Am79C978A controller may enter the suspend mode with transmit and/or receive packets still in the FIFOs or the SRAM. This offers a worst case suspend time of a maximum length packet over the possibility of completely emptying the SRAM. Care must be exercised in this mode, because the entire memory subsystem of the Am79C978A controller is suspended. Any changes to either the descriptor rings or the SRAM can cause the Am79C978A controller to start up in an unknown condition and could cause data corruption.

When FASTSPNDE is 0 and the SPND bit is set, the Am79C978A controller may take longer before entering the suspend mode. At the time the SPND bit is set, the Am79C978A controller will complete the DMA process of a transmit packet if it had already begun, and the Am79C978A controller will completely receive a receive packet if it had already begun. The Am79C978A controller will not receive any new packets after the completion of the current reception. Additionally, all transmit packets stored in the transmit FIFOs and the transmit buffer area in the SRAM (if one is present) will be transmitted, and all receive packets stored in the receive FIFOs and the receive buffer area in the SRAM (if selected) will be transferred into system memory. Since the FIFO and the SRAM contents are flushed, it may take much longer before the Am79C978A controller enters the suspend mode. The amount of time that it takes depends on many factors including the size of the SRAM, bus latency, and network traffic level.

Upon completion of the described operations, the Am79C978A controller sets the read-version of SPND to 1 and enters the suspend mode. In suspend mode, all of the CSR and BCR registers are accessible. As long as the Am79C978A controller is not reset while in suspend mode (by H_RESET, S_RESET, or by setting the STOP bit), no re-initialization of the device is required after the device comes out of suspend mode. When SPND is set to 0, the Am79C978A controller will leave the suspend mode and will continue at the transmit and receive descriptor ring locations where it was when it entered the suspend mode.

See the section on *Magic Packet* technology for details on how that affects suspension of the integrated Ethernet controller.

Buffer Management

Buffer management is accomplished through message descriptor entries organized as ring structures in memory. There are two descriptor rings, one for transmit and one for receive. Each descriptor describes a single buffer. A frame may occupy one or more buffers. If multiple buffers are used, this is referred to as buffer chaining.

Descriptor Rings

Each descriptor ring must occupy a contiguous area of memory. During initialization, the user-defined base address for the transmit and receive descriptor rings, as well as the number of entries contained in the descriptor rings are set up. The programming of the software style (SWSTYLE, BCR20, bits 7-0) affects the way the descriptor rings and their entries are arranged.

When SWSTYLE is at its default value of 0, the descriptor rings are backwards compatible with the Am79C90 C-LANCE and the Am79C96x PCnet-ISA family. The descriptor ring base addresses must be aligned to an 8-byte boundary and a maximum of 128

ring entries is allowed when the ring length is set through the TLEN and RLEN fields of the initialization block. Each ring entry contains a subset of the three 32-bit transmit or receive message descriptors (TMD, RMD) that are organized as four 16-bit structures (SSIZE32 (BCR20, bit 8) is set to 0). Note that even though the Am79C978A controller treats the descriptor entries as 16-bit structures, it will always perform 32-bit bus transfers to access the descriptor entries. The value of CSR2, bits 15-8, is used as the upper 8-bits for all memory addresses during bus master transfers.

When SWSTYLE is set to 2 or 3, the descriptor ring base addresses must be aligned to a 16-byte boundary, and a maximum of 512 ring entries is allowed when the ring length is set through the TLEN and RLEN fields of the initialization block. Each ring entry is organized as three 32-bit message descriptors (SSIZE32 (BCR20, bit 8) is set to 1). The fourth DWord is reserved. When SWSTYLE is set to 3, the order of the message descriptors is optimized to allow read and write access in burst mode.

For any software style, the ring lengths can be set beyond this range (up to 65535) by writing the transmit and receive ring length registers (CSR76, CSR78) directly.

Each ring entry contains the following information:

- The address of the actual message data buffer in user or host memory
- The length of the message buffer
- Status information indicating the condition of the buffer

To permit the queuing and de-queuing of message buffers, ownership of each buffer is allocated to either the Am79C978A controller or the host. The OWN bit within the descriptor status information, either TMD or RMD, is used for this purpose.

When OWN is set to 1, it signifies that the Am79C978A controller currently has ownership of this ring descriptor and its associated buffer. Only the owner is permitted to relinquish ownership or to write to any field in the descriptor entry. A device that is not the current owner of a descriptor entry cannot assume ownership or change any field in the entry. A device may, however, read from a descriptor that it does not currently own. Software should always read descriptor entries in sequential order. When software finds that the current descriptor is owned by the Am79C978A controller, then the software must not read ahead to the next descriptor. The software should wait at a descriptor it does not own until the Am79C978A controller sets OWN to 0 to release ownership to the software. When LAPPEN (CSR3, bit 5) is set to 1, this rule is modified. See the LAPPEN description. At initialization, the Am79C978A controller reads the base address of both the transmit

and receive descriptor rings into CSRs for use by the Am79C978A controller during subsequent operations.

Figure 33 illustrates the relationship between the initialization base address, the initialization block, the receive and transmit descriptor ring base addresses, the receive and transmit descriptors, and the receive and transmit data buffers, when SSize32 is cleared to 0.

Note that the value of CSR2, bits 15-8, is used as the upper 8-bits for all memory addresses during bus master transfers.

Figure 34 illustrates when SSize32 is set to 1, the relationship between the initialization base address, the initialization block, the receive and transmit descriptor ring base addresses, the receive and transmit descriptors, and the receive and transmit data buffers.

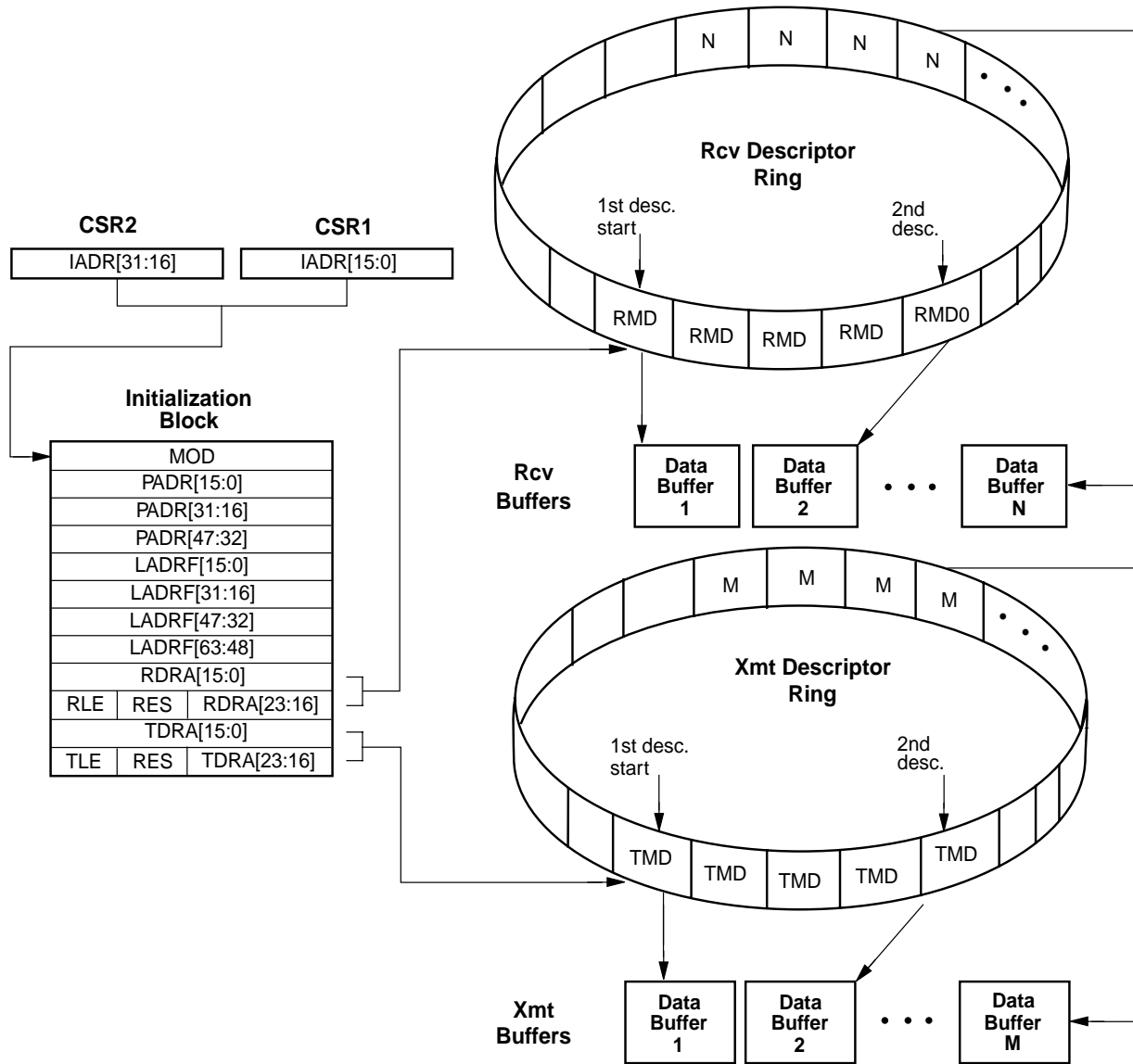

22399A-36

Figure 33. 16-Bit Software Model

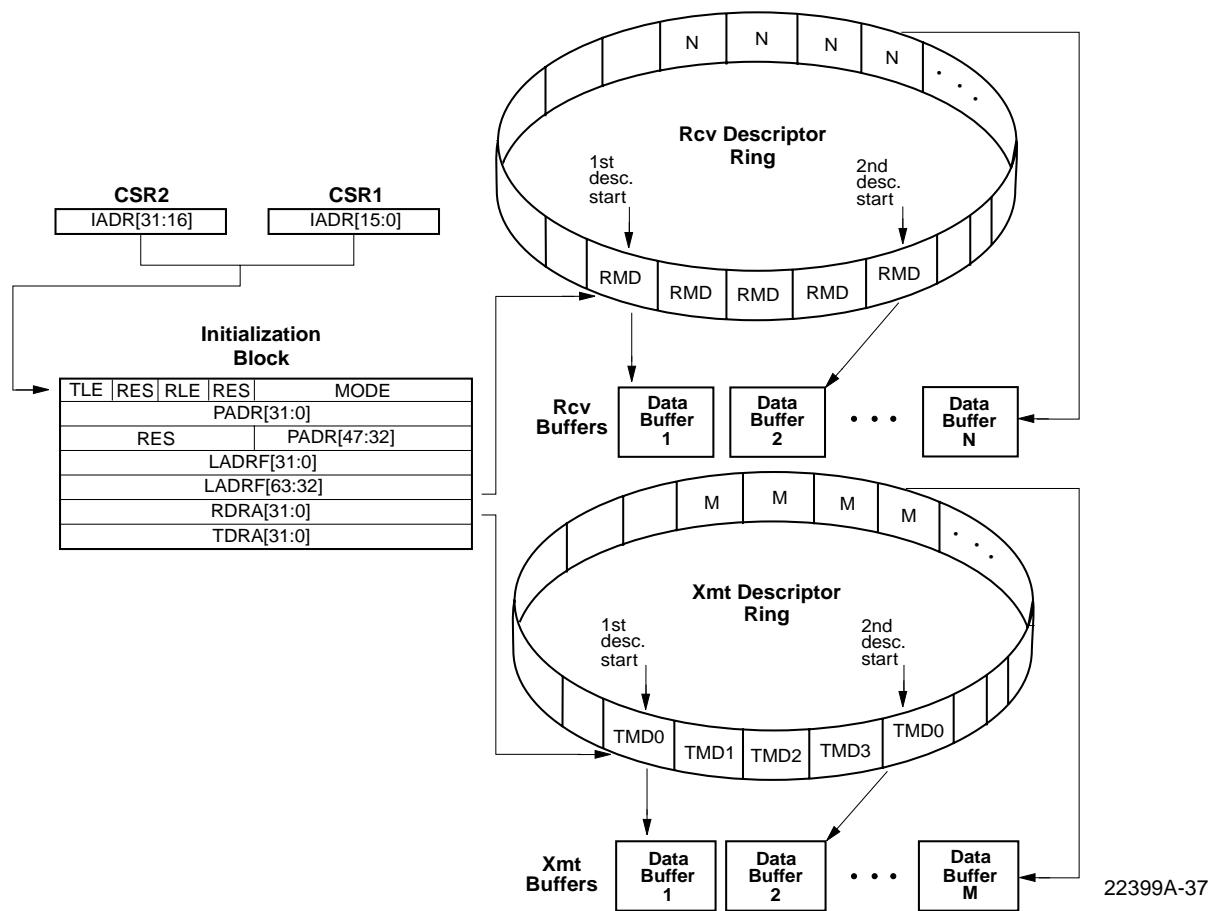

Figure 34. 32-Bit Software Model

Polling

If there is no network channel activity and there is no pre- or post-receive or pre- or post-transmit activity being performed by the Am79C978A controller, then the Am79C978A controller will periodically poll the current receive and transmit descriptor entries in order to ascertain their ownership. If the DPOLL bit in CSR4 is set, then the transmit polling function is disabled.

A typical polling operation consists of the following sequence. The Am79C978A controller will use the current receive descriptor address stored internally to vector to the appropriate Receive Descriptor Table Entry (RDTE). It will then use the current transmit descriptor address (stored internally) to vector to the appropriate Transmit Descriptor Table Entry (TDTE). The accesses will be made in the following order: RMD1, then RMD0 of the current RDTE during one bus arbitration, and after that, TMD1, then TMD0 of the current TDTE during a second bus arbitration. All information collected during polling activity will be stored internally in the appropriate CSRs, if the OWN bit is set (i.e., CSR18, CSR19, CSR20, CSR21, CSR40, CSR42, CSR50, CSR52).

A typical receive poll is the product of the following conditions:

1. The controller does not own the current RDTE *and* the poll time has elapsed *and* RXON = 1 (CSR0, bit 5), *or*
2. The controller does not own the next RDTE *and* there is more than one receive descriptor in the ring *and* the poll time has elapsed *and* RXON = 1.

If RXON is cleared to 0, the Am79C978A controller will never poll RDTE locations.

In order to avoid missing frames, the system should have at least one RDTE available. To minimize poll activity, two RDTEs should be available. In this case, the poll operation will only consist of the check of the status of the current TDTE.

A typical transmit poll is the product of the following conditions:

1. The controller does not own the current TDTE *and* TXDPOLL = 0 (CSR4, bit 12) *and* TXON = 1 (CSR0, bit 4) *and* the poll time has elapsed, *or*
2. The controller does not own the current TDTE *and* TXDPOLL = 0 *and* TXON = 1 *and* a frame has just been received, *or*
3. The controller does not own the current TDTE *and* TXDPOLL = 0 *and* TXON = 1 *and* a frame has just been transmitted.

Setting the TDMD bit of CSR0 will cause the microcode controller to exit the poll counting code and immediately perform a polling operation. If RDTE ownership has not been previously established, then an RDTE poll will be performed ahead of the TDTE poll. If the microcode is not executing the poll counting code when the TDMD bit is set, then the demanded poll of the TDTE will be delayed until the microcode returns to the poll counting code.

The user may change the poll time value from the default of 65,536 clock periods by modifying the value in the Polling Interval register (CSR47).

Transmit Descriptor Table Entry

If, after a Transmit Descriptor Table Entry (TDTE) access, the Am79C978A controller finds that the OWN bit of that TDTE is not set, the Am79C978A controller resumes the poll time count and re-examines the same TDTE at the next expiration of the poll time count.

If the OWN bit of the TDTE is set, but the Start of Packet (STP) bit is not set, the Am79C978A controller will immediately request the bus in order to clear the OWN bit of this descriptor. (This condition would normally be found following a late collision (LCOL) or retry (RTRY) error that occurred in the middle of a transmit frame chain of buffers.) After resetting the OWN bit of this descriptor, the Am79C978A controller will again immediately request the bus in order to access the next TDTE location in the ring.

If the OWN bit is set and the buffer length is 0, the OWN bit will be cleared. In the C-LANCE device, the buffer length of 0 is interpreted as a 4096-byte buffer. A zero length buffer is acceptable as long as it is not the last buffer in a chain (STP = 0 and ENP = 1).

If the OWN bit and STP are set, then microcode control proceeds to a routine that will enable transmit data transfers to the FIFO. The Am79C978A controller will look ahead to the next transmit descriptor after it has performed at least one transmit data transfer from the first buffer.

If the Am79C978A controller does not own the next TDTE (i.e., the second TDTE for this frame), it will complete transmission of the current buffer and update the

status of the current (first) TDTE with the BUFF and UFLO bits being set. If DXSUFLO (CSR3, bit 6) is cleared to 0, the underflow error will cause the transmitter to be disabled (CSR0, TXON = 0). The Am79C978A controller will have to be re-initialized to restore the transmit function. Setting DXSUFLO to 1 enables the Am79C978A controller to gracefully recover from an underflow error. The device will scan the transmit descriptor ring until it finds either the start of a new frame or a TDTE it does not own. To avoid an underflow situation in a chained buffer transmission, the system should always set the transmit chain descriptor own bits in reverse order.

If the Am79C978A controller does own the second TDTE in a chain, it will gradually empty the contents of the first buffer (as the bytes are needed by the transmit operation), perform a single-cycle DMA transfer to update the status of the first descriptor (clear the OWN bit in TMD1), and then it may perform one data DMA access on the second buffer in the chain before executing another lookahead operation. (i.e., a lookahead to the third descriptor.)

It is imperative that the host system never reads the TDTE OWN bits out of order. The Am79C978A controller normally clears OWN bits in strict FIFO order. However, the Am79C978A controller can queue up to two frames in the transmit FIFO. When the second frame uses buffer chaining, the Am79C978A controller might return ownership out of normal FIFO order. The OWN bit for the last (and maybe only) buffer of the first frame is not cleared until transmission is completed. During the transmission the Am79C978A controller will read in buffers for the next frame and clear their OWN bits for all but the last one. The first and all intermediate buffers of the second frame can have their OWN bits cleared before the Am79C978A controller returns ownership for the last buffer of the first frame.

If an error occurs in the transmission before all of the bytes of the current buffer have been transferred, transmit status of the current buffer will be immediately updated. If the buffer does not contain the end of packet, the Am79C978A controller will skip over the rest of the frame which experienced the error. This is done by returning to the polling microcode where the Am79C978A controller will clear the OWN bit for all descriptors with OWN = 1 and STP = 0 and continue in like manner until a descriptor with OWN = 0 (no more transmit frames in the ring) or OWN = 1 and STP = 1 (the first buffer of a new frame) is reached.

At the end of any transmit operation, whether successful or with errors, immediately following the completion of the descriptor updates, the Am79C978A controller will always perform another polling operation. As described earlier, this polling operation will begin with a check of the current RDTE, unless the Am79C978A controller already owns that descriptor. Then the

Am79C978A controller will poll the next TDTE. If the transmit descriptor OWN bit has a 0 value, the Am79C978A controller will resume incrementing the poll time counter. If the transmit descriptor OWN bit has a value of 1, the Am79C978A controller will begin filling the FIFO with transmit data and initiate a transmission. This end-of-operation poll coupled with the TDTE look-ahead operation allows the Am79C978A controller to avoid inserting poll time counts between successive transmit frames.

By default, whenever the Am79C978A controller completes a transmit frame (either with or without error) and writes the status information to the current descriptor, then the TINT bit of CSR0 is set to indicate the completion of a transmission. This causes an interrupt signal if the IENA bit of CSR0 has been set and the TINTM bit of CSR3 is cleared. The Am79C978A controller provides two modes to reduce the number of transmit interrupts. The interrupt of a successfully transmitted frame can be suppressed by setting TINTOKD (CSR5, bit 15) to 1. Another mode, which is enabled by setting LTINTEN (CSR5, bit 14) to 1, allows suppression of interrupts for successful transmissions for all but the last frame in a sequence.

Receive Descriptor Table Entry

If the Am79C978A controller does not own both the current and the next Receive Descriptor Table Entry (RDTE), then the Am79C978A controller will continue to poll according to the polling sequence described above. If the receive descriptor ring length is one, then there is no next descriptor to be polled.

If a poll operation has revealed that the current and the next RDTE belong to the Am79C978A controller, then additional poll accesses are not necessary. Future poll operations will not include RDTE accesses as long as the Am79C978A controller retains ownership of the current and the next RDTE.

When receive activity is present on the channel, the Am79C978A controller waits for the complete address of the message to arrive. It then decides whether to accept or reject the frame based on all active addressing schemes. If the frame is accepted, the Am79C978A controller checks the current receive buffer status register CRST (CSR41) to determine the ownership of the current buffer.

If ownership is lacking, the Am79C978A controller will immediately perform a final poll of the current RDTE. If ownership is still denied, the Am79C978A controller has no buffer in which to store the incoming message. The MISS bit will be set in CSR0 and the Missed Frame Counter (CSR112) will be incremented. Another poll of the current RDTE will not occur until the frame has finished.

If the Am79C978A controller sees that the last poll (either a normal poll, or the final effort described in the above paragraph) of the current RDTE shows valid ownership, it proceeds to a poll of the next RDTE. Following this poll, and regardless of the outcome of this poll, transfers of receive data from the FIFO may begin.

Regardless of ownership of the second receive descriptor, the Am79C978A controller will continue to perform receive data DMA transfers to the first buffer. If the frame length exceeds the length of the first buffer, and the Am79C978A controller does not own the second buffer, ownership of the current descriptor will be passed back to the system by writing a 0 to the OWN bit of RMD1. Status will be written indicating buffer (BUFF = 1) and possibly overflow (OFLO = 1) errors.

If the frame length exceeds the length of the first (current) buffer, and the Am79C978A controller does own the second (next) buffer, ownership will be passed back to the system by writing a 0 to the OWN bit of RMD1 when the first buffer is full. The OWN bit is the only bit modified in the descriptor. Receive data transfers to the second buffer may occur before the Am79C978A controller proceeds to look ahead to the ownership of the third buffer. Such action will depend upon the state of the FIFO when the OWN bit has been updated in the first descriptor. In any case, lookahead will be performed to the third buffer and the information gathered will be stored in the chip, regardless of the state of the ownership bit.

This activity continues until the Am79C978A controller recognizes the completion of the frame (the last byte of this receive message has been removed from the FIFO). The Am79C978A controller will subsequently update the current RDTE status with the end of frame (ENP) indication set, write the message byte count (MCNT) for the entire frame into RMD2, and overwrite the "current" entries in the CSRs with the "next" entries.

Receive Frame Queuing

The Am79C978A controller supports the lack of RDTEs when SRAM (SRAM SIZE in BCR 25, bits 7-0) is enabled through the Receive Frame Queuing mechanism. When the SRAM SIZE = 0, then the Am79C978A controller reverts back to the PCnet-PCI II mode of operation. This operation is automatic and does not require any programming by the host. When SRAM is enabled, the Receive Frame Queuing mechanism allows a slow protocol to manage more frames without the high frame loss rate normally attributed to FIFO-based network controllers.

The Am79C978A controller will store the incoming frames in the extended FIFOs until polling takes place, if enabled and it discovers it owns an RDTE. The stored frames are not altered in any way until written out into system buffers. When the receive FIFO overflows, further incoming receive frames will be missed during that

time. As soon as the network receive FIFO is empty, incoming frames are processed as normal. Status on a per frame basis is not kept during the overflow process. Statistic counters are maintained and accurate during that time.

During the time that the Receive Frame Queuing mechanism is in operation, the Am79C978A controller relies on the Receive Poll Time Counter (CSR 48) to control the worst case access to the RDTE. The Receive Poll Time Counter is programmed through the Receive Polling Interval (CSR49) register. The Received Polling Interval defaults to approximately 2 ms. The Am79C978A controller will also try to access the RDTE during normal descriptor accesses whether they are transmit or receive accesses. The host can force the Am79C978A controller to immediately access the RDTE by setting the RDMD (CSR 7, bit 13) to 1. Its operation is similar to the transmit one. The polling process can be disabled by setting the RXDPOLL (CSR7, bit 12) bit. This will stop the automatic polling process and the host must set the RDMD bit to initiate the receive process into host memory. Receive frames are still stored even when the receive polling process is disabled.

Software Interrupt Timer

The Am79C978A controller is equipped with a software programmable free-running interrupt timer. The timer is constantly running and will generate an interrupt STINT (CSR 7, bit 11) when STINITE (CSR 7, bit 10) is set to 1. After generating the interrupt, the software timer will load the value stored in STVAL and restart. The timer value STVAL (BCR31, bits 15-0) is interpreted as an unsigned number with a resolution of 256 Time Base Clock periods. For instance, a value of 122 ms would be programmed with a value of 9531 (253Bh), if the Time Base Clock is running at 20 MHz. The default value of STVAL is FFFFh which yields the approximate maximum 838 ms timer duration. A write to STVAL restarts the timer with the new contents of STVAL.

10/100 Media Access Controller

The Media Access Controller (MAC) engine incorporates the essential protocol requirements for operation of an Ethernet/IEEE 802.3-compliant node and provides the interface between the FIFO subsystem and the internal PHY.

This section describes operation of the MAC engine when operating in half-duplex mode. When operating in half-duplex mode, the MAC engine is fully compliant to Section 4 of ISO/IEC 8802-3 (ANSI/IEEE Standard 1990 Second Edition) and ANSI/IEEE 802.3 (1985). When operating in full-duplex mode, the MAC engine behavior changes as described in the section *Full-Duplex Operation*.

The MAC engine provides programmable enhanced features designed to minimize host supervision, bus utilization, and pre- or post-message processing. These features include the ability to disable retries after a collision, dynamic FCS generation on a frame-by-frame basis, automatic pad field insertion and deletion to enforce minimum frame size attributes, automatic retransmission without reloading the FIFO, and automatic deletion of collision fragments.

The two primary attributes of the MAC engine are:

- Transmit and receive message data encapsulation
 - Framing (frame boundary delimitation, frame synchronization)
 - Addressing (source and destination address handling)
 - Error detection (physical medium transmission errors)
- Media access management
 - Medium allocation (collision avoidance, except in full-duplex operation)
 - Contention resolution (collision handling, except in full-duplex operation)

Transmit and Receive Message Data Encapsulation

The MAC engine provides minimum frame size enforcement for transmit and receive frames. When APAD_XMT (CSR, bit 11) is set to 1, transmit messages will be padded with sufficient bytes (containing 00h) to ensure that the receiving station will observe an information field (destination address, source address, length/type, data, and FCS) of 64 bytes. When ASTRP_RCV (CSR4, bit 10) is set to 1, the receiver will automatically strip pad bytes from the received message by observing the value in the length field and by stripping excess bytes if this value is below the minimum data size (46 bytes). Both features can be independently over-ridden to allow illegally short (less than 64 bytes of frame data) messages to be transmitted and/or received. The use of this feature reduces bus utilization because the pad bytes are not transferred into or out of main memory.

Framing

The MAC engine will autonomously handle the construction of the transmit frame. Once the transmit FIFO has been filled to the predetermined threshold (set by XMTSP in CSR80) and access to the channel is currently permitted, the MAC engine will commence the 7-byte preamble sequence (10101010b, where first bit transmitted is a 1). The MAC engine will subsequently append the Start Frame Delimiter (SFD) byte (10101011b) followed by the serialized data from the transmit FIFO. Once the data has been completed, the MAC engine will append the FCS (most significant bit first), which was computed on the en-

tire data portion of the frame. The data portion of the frame consists of destination address, source address, length/type, and frame data. The user is responsible for the correct ordering and content in each of these fields in the frame. The MAC does not use the content in the length/type field unless APAD_XMT (CSR4, bit 11) is set and the data portion of the frame is shorter than 60 bytes.

The MAC engine will detect the incoming preamble sequence when the RX_DV signal is activated by the internal PHY. The MAC will discard the preamble and begin searching for the SFD. Once the SFD is detected, all subsequent nibbles are treated as part of the frame. The MAC engine will inspect the length field to ensure minimum frame size, strip unnecessary pad characters (if enabled), and pass the remaining bytes through the receive FIFO to the host. If pad stripping is performed, the MAC engine will also strip the received FCS bytes, although normal FCS computation and checking will occur. Note that apart from pad stripping, the frame will be passed unmodified to the host. If the length field has a value of 46 or greater, all frame bytes including FCS will be passed unmodified to the receive buffer, regardless of the actual frame length.

If the frame terminates or suffers a collision before 64 bytes of information (after SFD) have been received, the MAC engine will automatically delete the frame from the receive FIFO, without host intervention. The Am79C978A controller has the ability to accept runt packets for diagnostic purposes and proprietary networks.

Destination Address Handling

The first 6 bytes of information after SFD will be interpreted as the destination address field. The MAC engine provides facilities for physical (unicast), logical (multicast), and broadcast address reception.

Error Detection

The MAC engine provides several facilities which report and recover from errors on the medium. In addition, it protects the network from gross errors due to inability of the host to keep pace with the MAC engine activity.

On completion of transmission, the following transmit status is available in the appropriate Transmit Message Descriptor (TMD) and Control and Status Register (CSR) areas:

- The number of transmission retry attempts (ONE, MORE, RTRY, and TRC).
- Whether the MAC engine had to Defer (DEF) due to channel activity.
- Excessive deferral (EXDEF), indicating that the transmitter experienced Excessive Deferral on this transmit frame, where Excessive Deferral is defined in the ISO 8802-3 (IEEE/ANSI 802.3) standard.
- Loss of Carrier (LCAR), indicating that there was an interruption in the ability of the MAC engine to monitor its own transmission. Repeated LCAR errors indicate a potentially faulty transceiver or network connection.
- Late Collision (LCOL) indicates that the transmission suffered a collision after the slot time. This is indicative of a badly configured network. Late collisions should not occur in a normal operating network.
- Collision Error (CERR) indicates that the transceiver did not respond with an SQE Test message within the first 4 ms after a transmission was completed. This may be due to a failed transceiver, disconnected or faulty transceiver drop cable, or because the transceiver does not support this feature (or it is disabled). SQE Test is only valid for 10-Mbps networks.

In addition to the reporting of network errors, the MAC engine will also attempt to prevent the creation of any network error due to the inability of the host to service the MAC engine. During transmission, if the host fails to keep the transmit FIFO filled sufficiently, causing an underflow, the MAC engine will guarantee the message is either sent as a runt packet (which will be deleted by the receiving station) or as an invalid FCS (which will also cause the receiver to reject the message).

The status of each receive message is available in the appropriate Receive Message Descriptor (RMD) and CSR areas. All received frames are passed to the host regardless of any error. The FRAM error will only be reported if an FCS error is detected and there is a non-integral number of bytes in the message.

During the reception, the FCS is generated on every nibble (including the dribbling bits) coming from the cable, although the internally saved FCS value is only updated on the eighth bit (on each byte boundary). The MAC engine will ignore up to 7 additional bits at the end of a message (dribbling bits), which can occur under normal network operating conditions. The framing error is reported to the user as follows:

- If the number of dribbling bits are 1 to 7 and there is no FCS error, then there is no Framing error (FRAM = 0).
- If the number of dribbling bits are 1 to 7 and there is a FCS error, then there is also a Framing error (FRAM = 1).
- If the number of dribbling bits is 0, then there is no Framing error. There may or may not be a FCS error.
- If the number of dribbling bits is 8, then there is no Framing error. FCS error will be reported, and the receive message count will indicate one extra byte.

Counters are provided to report the Receive Collision Count and Runt Packet Count for network statistics and utilization calculations.

Media Access Management

The basic requirement for all stations on the network is to provide fairness of channel allocation. The IEEE 802.3/Ethernet protocols define a media access mechanism which permits all stations to access the channel with equality. Any node can attempt to contend for the channel by waiting for a predetermined time (Inter Packet Gap) after the last activity, before transmitting on the media. The channel is a multidrop communications media (with various topological configurations permitted), which allows a single station to transmit and all other stations to receive. If two nodes simultaneously contend for the channel, their signals will interact causing loss of data, defined as a collision. It is the responsibility of the MAC to attempt to avoid and recover from a collision and to guarantee data integrity for the end-to-end transmission to the receiving station.

Medium Allocation

The IEEE/ANSI 802.3 standard (ISO/IEC 8802-3 1990) requires that the CSMA/CD MAC monitor the medium for traffic by watching for carrier activity. When carrier is detected, the media is considered busy, and the MAC should defer to the existing message.

The ISO 8802-3 (IEEE/ANSI 802.3) standard also allows optionally a two-part deferral after a receive message.

See ANSI/IEEE Std 802.3-1993 Edition, 4.2.3.2.1:

Note: *“It is possible for the PLS carrier sense indication to fail to be asserted during a collision on the media. If the deference process simply times the inter-frame gap based on this indication, it is possible for a short interframe gap to be generated, leading to a potential reception failure of a subsequent frame. To enhance system robustness, the following optional measures (as specified in 4.2.8) are recommended when InterFrameSpacingPart1 is other than 0:*

1. *Upon completing a transmission, start timing the interrupted gap as soon as transmitting and carrier sense are both false.*
2. *When timing an inter-frame gap following reception, reset the inter-frame gap timing if carrier sense becomes true during the first 2/3 of the inter-frame gap timing interval. During the final 1/3 of the interval, the timer shall not be reset to ensure fair access to the medium. An initial period shorter than 2/3 of the interval is permissible including 0.”*

The MAC engine implements the optional receive two-part deferral algorithm, with an InterFrameSpacingPart1 time of 6.0 ms. The InterFrameSpacingPart2 interval is, therefore, 3.4 ms.

TheAm79C978A controller will perform the two-part deferral algorithm as specified in the *Process Deferral* section. The Inter Packet Gap (IPG) timer will start timing the 9.6 ms InterFrameSpacing after the receive carrier is deasserted. During the first part deferral (InterFrameSpacingPart1 - IFS1), the Am79C978A controller will defer any pending transmit frame and respond to the receive message. The IPG counter will be cleared to 0 continuously until the carrier deasserts, at which point the IPG counter will resume the 9.6 ms count once again. Once the IFS1 period of 6.0 ms has elapsed, the Am79C978A controller will begin timing the second part deferral (InterFrameSpacingPart2 - IFS2) of 3.4 ms. Once IFS1 has completed and IFS2 has commenced, the Am79C978A controller will not defer to a receive frame if a transmit frame is pending. This means that the Am79C978A controller will not attempt to receive the receive frame, since it will start to transmit and generate a collision at 9.6 ms. TheAm79C978A controller will complete the preamble (64-bit) and jam (32-bit) sequence before ceasing transmission and invoking the random backoff algorithm.

TheAm79C978A controller allows the user to program the IPG and the first-part deferral (InterFrameSpacingPart1 - IFS1) through CSR125. By changing the IPG default value of 96 bit times (60h), the user can adjust the fairness or aggressiveness of the MAC on the network. By programming a lower number of bit times than the ISO/IEC 8802-3 standard requires, the MAC engine will become more aggressive on the network. This aggressive nature will give rise to the Am79C978A controller possibly capturing the network at times by forcing other less aggressive compliant nodes to defer. By programming a larger number of bit times, the MAC will become less aggressive on the network and may defer more often than normal. The performance of the Am79C978A controller may decrease as the IPG value is increased from the default value, but the resulting behavior may improve network performance by reducing collisions. TheAm79C978A controller uses the same IPG for back-to-back transmits and receive-to-transmit accesses. Changing IFS1 will alter the period for which the MAC engine will defer to incoming receive frames.

CAUTION: Care must be exercised when altering these parameters. Adverse network activity could result!

This transmit two-part deferral algorithm is implemented as an option which can be disabled using the DXMT2PD bit in CSR3. The IFS1 programming will have no effect when DXMT2PD is set to 1, but the IPG programming value is still valid. Two part deferral after transmission is useful for ensuring that severe IPG shrinkage cannot occur in specific circumstances,

causing a transmit message to follow a receive message so closely as to make them indistinguishable.

During the time period immediately after a transmission has been completed, the external transceiver should generate the SQE Test message within 0.6 to 1.6 ms after the transmission ceases. During the time period in which the SQE Test message is expected, the Am79C978A controller will not respond to receive carrier sense.

See ANSI/IEEE Std 802.3-1993 Edition, 7.2.4.6 (1):

“At the conclusion of the output function, the DTE opens a time window during which it expects to see the signal_quality_error signal asserted on the Control In circuit. The time window begins when the CARRIER_STATUS becomes CARRIER_OFF. If execution of the output function does not cause CARRIER_ON to occur, no SQE test occurs in the DTE. The duration of the window shall be at least 4.0 μs but no more than 8.0 μs. During the time window the Carrier Sense Function is inhibited.”

The Am79C978A controller implements a carrier sense “blinding” period of 4.0 μs length starting from the deassertion of carrier sense after transmission. This effectively means that when transmit two-part deferral is enabled (DXMT2PD is cleared), the IFS1 time is from 4 ms to 6 ms after a transmission. However, since IPG shrinkage below 4 ms will rarely be encountered on a correctly configured network, and since the fragment size will be larger than the 4 ms blinding window, the IPG counter will be reset by a worst case IPG shrinkage/fragment scenario and the Am79C978A controller will defer its transmission. If carrier is detected within the 4.0 to 6.0 ms IFS1 period, the Am79C978A controller will not restart the “blinding” period, but only restart IFS1.

Collision Handling

Collision detection is performed and reported to the MAC engine via the COL input pin.

If a collision is detected before the complete preamble/SFD sequence has been transmitted, the MAC engine will complete the preamble/SFD before appending the jam sequence. If a collision is detected after the preamble/SFD has been completed, but prior to 512 bits being transmitted, the MAC engine will abort the transmission and append the jam sequence immediately. The jam sequence is a 32-bit all zeros pattern.

The MAC engine will attempt to transmit a frame a total of 16 times (initial attempt plus 15 retries) due to normal collisions (those within the slot time). Detection of collision will cause the transmission to be rescheduled to a time determined by the random backoff algorithm. If a single retry was required, the 1 bit will be set in the transmit frame status. If more than one retry was required, the MORE bit will be set. If all 16 at-

tempts experienced collisions, the RTRY bit will be set (1 and MORE will be clear), and the transmit message will be flushed from the FIFO. If retries have been disabled by setting the DRTY bit in CSR15, the MAC engine will abandon transmission of the frame on detection of the first collision. In this case, only the RTRY bit will be set, and the transmit message will be flushed from the FIFO.

If a collision is detected after 512 bit times have been transmitted, the collision is termed a late collision. The MAC engine will abort the transmission, append the jam sequence, and set the LCOL bit. No retry attempt will be scheduled on detection of a late collision, and the transmit message will be flushed from the FIFO.

The ISO 8802-3 (IEEE/ANSI 802.3) Standard requires use of a “truncated binary exponential backoff” algorithm, which provides a controlled pseudo random mechanism to enforce the collision backoff interval, before retransmission is attempted.

See ANSI/IEEE Std 802.3-1990 Edition, 4.2.3.2.5:

“At the end of enforcing a collision (jamming), the CSMA/CD sublayer delays before attempting to retransmit the frame. The delay is an integer multiple of slot time. The number of slot times to delay before the nth retransmission attempt is chosen as a uniformly distributed random integer r in the range:

$$0 \leq r < 2k \text{ Where } k = \text{Min}(N, 10).”$$

The Am79C978A controller provides an alternative algorithm, which suspends the counting of the slot time/IPG during the time that receive carrier sense is detected. This aids in networks where large numbers of nodes are present, and numerous nodes can be in collision. It effectively accelerates the increase in the backoff time in busy networks and allows nodes not involved in the collision to access the channel, while the colliding nodes await a reduction in channel activity. Once channel activity is reduced, the nodes resolving the collision time-out their slot time counters as normal.

This modified backoff algorithm is enabled when EMBA (CSR3, bit 3) is set to 1.

Transmit Operation

The transmit operation and features of the Am79C978A controller are controlled by programmable options. The Am79C978A controller offers a large transmit FIFO to provide frame buffering for increased system latency, automatic retransmission with no FIFO reload, and automatic transmit padding.

Transmit Function Programming

Automatic transmit features such as retry on collision, FCS generation/transmission, and pad field insertion can all be programmed to provide flexibility in the (re-) transmission of messages.

Disable retry on collision (DRTY) is controlled by the DRTY bit of the Mode register (CSR15) in the initialization block.

Automatic pad field insertion is controlled by the APAD_XMT bit in CSR4.

The disable FCS generation/transmission feature can be programmed as a static feature or dynamically on a frame-by-frame basis.

Transmit FIFO Watermark (XMTFW) in CSR80 sets the point at which the BMU requests more data from the transmit buffers for the FIFO. A minimum of XMTFW empty spaces must be available in the transmit FIFO before the BMU will request the system bus in order to transfer transmit frame data into the transmit FIFO.

Transmit Start Point (XMTSP) in CSR80 sets the point when the transmitter actually attempts to transmit a frame onto the media. A minimum of XMTSP bytes must be written to the transmit FIFO for the current frame before transmission of the current frame will begin. (When automatically padded packets are being sent, it is conceivable that the XMTSP is not reached when all of the data has been transferred to the FIFO. In this case, the transmission will begin when all of the frame data has been placed into the transmit FIFO.) The default value of XMTSP is 01b, meaning there has to be 64 bytes in the transmit FIFO to start a transmission.

Automatic Pad Generation

Transmit frames can be automatically padded to extend them to 64 data bytes (excluding preamble). This allows the minimum frame size of 64 bytes (512 bits) for IEEE 802.3/Ethernet to be guaranteed with no software intervention from the host/controlling process. Setting the APAD_XMT bit in CSR4 enables the automatic padding feature. The pad is placed between the LLC data field and FCS field in the IEEE 802.3 frame. FCS is always added if the frame is padded, regardless of the state of DXMTFCS (CSR15, bit 3) or ADD_FCS (TMD1, bit 29). The transmit frame will be padded by

bytes with the value of 00h. The default value of APAD_XMT is 0, which will disable automatic pad generation after H_RESET.

It is the responsibility of upper layer software to correctly define the actual length field contained in the message to correspond to the total number of LLC data bytes encapsulated in the frame (length field as defined in the ISO 8802-3 (IEEE/ANSI 802.3) standard). The length value contained in the message is not used by the Am79C978A controller to compute the actual number of pad bytes to be inserted. The Am79C978A controller will append pad bytes dependent on the actual number of bits transmitted onto the network. Once the last data byte of the frame has completed, prior to appending the FCS, the Am79C978A controller will check to ensure that 544 bits have been transmitted. If not, pad bytes are added to extend the frame size to this value, and the FCS is then added. See Figure 35.

The 544 bit count is derived from the following:

Minimum frame size (excluding preamble/SFD, including FCS)	64 bytes	512 bits
Preamble/SFD size	8 bytes	64 bits
FCS size	4 bytes	32 bits

The 544 bit count is derived from the following:

Minimum frame size (excluding preamble/SFD, including FCS)	64 bytes	512 bits
Preamble/SFD size	8 bytes	64 bits
FCS size	4 bytes	32 bits

At the point that FCS is to be appended, the transmitted frame should contain:

$$\text{Preamble/SFD} + (\text{Min Frame Size} - \text{FCS})$$

$$64 + (512 - 32) = 544 \text{ bits}$$

A minimum length transmit frame from the Am79C978A controller, therefore, will be 576 bits after the FCS is appended.

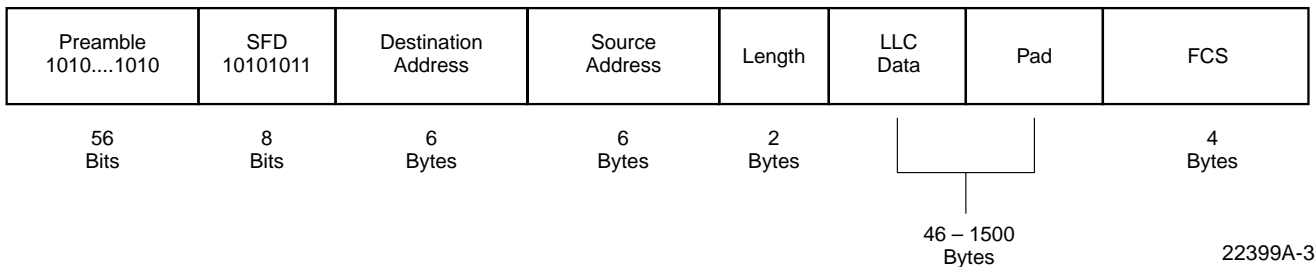

Figure 35. ISO 8802-3 (IEEE/ANSI 802.3) Data Frame

Transmit FCS Generation

Automatic generation and transmission of FCS for a transmit frame depends on the value of DXMTFCS (CSR15, bit 3). If DXMTFCS is cleared to 0, the transmitter will generate and append the FCS to the transmitted frame. If the automatic padding feature is invoked (APAD_XMT is set in CSR4), the FCS will be appended by the Am79C978A controller regardless of the state of DXMTFCS or ADD_FCS (TMD1, bit 29). Note that the calculated FCS is transmitted most significant bit first. The default value of DXMTFCS is 0 after H_RESET.

ADD_FCS (TMD1, bit 29) allows the automatic generation and transmission of FCS on a frame-by-frame basis. DXMTFCS should be cleared to 0 in this mode. To generate FCS for a frame, ADD_FCS must be set in all descriptors of a frame (STP is set to 1). Note that bit 29 of TMD1 has the function of ADD_FCS if SWSTYLE (BCR20, bits 7-0) is programmed to 0, 2, or 3.

Transmit Exception Conditions

Exception conditions for frame transmission fall into two distinct categories: those conditions which are the result of normal network operation, and those which occur due to abnormal network and/or host related events.

Normal events which may occur and which are handled autonomously by the Am79C978A controller include collisions within the slot time with automatic retry. The Am79C978A controller will ensure that collisions which occur within 512 bit times from the start of transmission (including preamble) will be automatically retried with no host intervention. The transmit FIFO ensures this by guaranteeing that data contained within the FIFO will not be overwritten until at least 64 bytes (512 bits) of preamble plus address, length, and data fields have been transmitted onto the network without encountering a collision. Note that if DRTY (CSR15, bit 5) is set to 1 or if the network interface is operating in full-duplex mode, no collision handling is required, and any byte of frame data in the FIFO can be overwritten as soon as it is transmitted.

If 16 total attempts (initial attempt plus 15 retries) fail, the Am79C978A controller sets the RTRY bit in the current transmit TDTE in host memory (TMD2), gives up ownership (resets the OWN bit to 0) for this frame, and processes the next frame in the transmit ring for transmission.

Abnormal network conditions include:

- Loss of carrier
- Late collision
- SQE Test Error (does not apply to 100 Mbps networks.)

These conditions should not occur on a correctly configured IEEE 802.3 network operating in half-duplex mode. If they do, they will be reported. None of these conditions will occur on a network operating in full-duplex mode. (See the section on *Full-Duplex Operation* for more detail.)

When an error occurs in the middle of a multi-buffer frame transmission, the error status will be written in the current descriptor. The OWN bit(s) in the subsequent descriptor(s) will be cleared until the STP (the next frame) is found.

Loss of Carrier

LCAR will be reported for every frame transmitted if the Am79C978A controller detects a loss of carrier.

Late Collision

A late collision will be reported if a collision condition occurs after one slot time (512 bit times) after the transmit process was initiated (first bit of preamble commenced). The Am79C978A controller will abandon the transmit process for that frame, set Late Collision (LCOL) in the associated TMD2, and process the next transmit frame in the ring. Frames experiencing a late collision will not be retried. Recovery from this condition must be performed by upper layer software.

SQE Test Error

If the network port is in Link Fail state, CERR will be asserted in the 10BASE-T mode after transmit. CERR will never cause $\overline{\text{INTA}}$ to be activated. It will, however, set the ERR bit CSR0.

Receive Operation

The receive operation and features of the Am79C978A controller are controlled by programmable options. The Am79C978A controller offers a large receive FIFO to provide frame buffering for increased system latency, automatic flushing of collision fragments (runt packets), automatic receive pad stripping, and a variety of address match options.

Receive Function Programming

Automatic pad field stripping is enabled by setting the ASTRP_RCV bit in CSR4. This can provide flexibility in the reception of messages using the IEEE 802.3 frame format.

All receive frames can be accepted by setting the PROM bit in CSR15. Acceptance of unicast and broadcast frames can be individually turned off by setting the DRCVPA or DRCVBC bits in CSR15. The Physical Address register (CSR12 to CSR14) stores the address that the Am79C978A controller compares to the destination address of the incoming frame for a unicast address match. The Logical Address Filter register (CSR8 to CSR11) serves as a hash filter for multicast address match.

The point at which the BMU will start to transfer data from the receive FIFO to buffer memory is controlled by the RCVFW bits in CSR80. The default established during H_RESET is 01b, which sets the watermark flag at 64 bytes filled.

For test purposes, the Am79C978A controller can be programmed to accept runt packets by setting RPA in CSR124.

Address Matching

The Am79C978A controller supports three types of address matching: unicast, multicast, and broadcast. The normal address matching procedure can be modified by programming three bits in CSR15, the mode register (PROM, DRCVPA, and DRCVBC).

If the first bit received after the SFD (the least significant bit of the first byte of the destination address field) is 0, the frame is unicast, which indicates that the frame is meant to be received by a single node. If the first bit received is 1, the frame is multicast, which indicates that the frame is meant to be received by a group of nodes. If the destination address field contains all 1s, the frame is broadcast, which is a special type of multicast. Frames with the broadcast address in the destination address field are meant to be received by all nodes on the local area network.

When a unicast frame arrives at the Am79C978A controller, the Am79C978A controller will accept the frame if the destination address field of the incoming frame exactly matches the 6-byte station address stored in the Physical Address registers (PADR, CSR12 to CSR14). The byte ordering is such that the first byte received from the network (after the SFD) must match the least significant byte of CSR12 (PADR[7:0]), and the sixth byte received must match the most significant byte of CSR14 (PADR[47:40]).

When DRCVPA (CSR15, bit 13) is set to 1, the Am79C978A controller will not accept unicast frames.

If the incoming frame is multicast, the Am79C978A controller performs a calculation on the contents of the destination address field to determine whether or not to accept the frame. This calculation is explained in the section that describes the Logical Address Filter (LADRF).

When all bits of the LADRF registers are 0, no multicast frames are accepted, except for broadcast frames.

Although broadcast frames are classified as special multicast frames, they are treated differently by the Am79C978A controller hardware. Broadcast frames are always accepted, except when DRCVBC (CSR15, bit 14) is set and there is no Logical Address match.

None of the address filtering described above applies when the Am79C978A controller is operating in the promiscuous mode. In the promiscuous mode, all properly formed packets are received, regardless of the contents of their destination address fields. The promiscuous mode overrides the Disable Receive Broadcast bit (DRCVBC bit 14 in the MODE register) and the Disable Receive Physical Address bit (DRCVPA, CSR15, bit 13).

The Am79C978A controller operates in promiscuous mode when PROM (CSR15, bit 15) is set.

The receive descriptor entry RMD1 contains three bits that indicate which method of address matching caused the Am79C978A controller to accept the frame. Note that these indicator bits are only available when the Am79C978A controller is programmed to use 32-bit structures for the descriptor entries (BCR20, bit 7-0, SWSTYLE is set to 2 or 3).

Physical Address Match (PAM) (RMD1, bit 22) is set by the Am79C978A controller when it accepts the received frame due to a match of the frame's destination address with the content of the physical address register.

Logical Address Filter Match (LAFM) (RMD1, bit 21) is set by the Am79C978A controller when it accepts the received frame based on the value in the logical address filter register.

Broadcast Address Match (BAM) (RMD1, bit 20) is set by the Am79C978A controller when it accepts the received frame because the frame's destination address type is *Broadcast*.

If DRCVBC (CSR15, bit 14) is cleared to 0, only BAM, but not LAFM will be set when a Broadcast frame is received, even if the Logical Address Filter is programmed in such a way that a Broadcast frame would pass the hash filter. If DRCVBC is set to 1 and the Logical Address Filter is programmed in such a way that a Broadcast frame would pass the hash filter, LAFM will be set on the reception of a Broadcast frame.

When the Am79C978A controller operates in promiscuous mode and none of the three match bits is set, it is an indication that the Am79C978A controller has only accepted the frame because it was in promiscuous mode.

When the Am79C978A controller is not programmed to be in promiscuous mode, then when none of the three match bits is set, it is an indication that the Am79C978A controller only accepted the frame because it was not rejected. See Table 11 for receive address matches.

Table 11. Receive Address Match

PAM	LAFM	BAM	DRCVBC	Comment
0	0	0	X	Frame accepted due to PROM = 1
1	0	0	X	Physical address match
0	1	0	0	Logical address filter match; frame is not of type broadcast
0	1	0	1	Logical address filter match; frame can be of type broadcast
0	0	1	0	Broadcast frame

Automatic Pad Stripping

During reception of an IEEE 802.3 frame, the pad field can be stripped automatically. Setting `ASTRP_RCV` (`CSR4`, bit 0) to 1 enables the automatic pad stripping feature. The pad field will be stripped before the frame is passed to the FIFO, thus preserving FIFO space for additional frames. The FCS field will also be stripped, since it is computed at the transmitting station based on the data and pad field characters, and will be invalid for a receive frame that has had the pad characters stripped.

The number of bytes to be stripped is calculated from the embedded length field (as defined in the ISO 8802-3 (IEEE/ANSI 802.3) definition) contained in the frame. The length indicates the actual number of LLC data bytes contained in the message. Any received frame which contains a length field less than 46 bytes will have the pad field stripped (if `ASTRP_RCV` is set). Receive frames which have a length field of 46 bytes or greater will be passed to the host unmodified.

Figure 36 shows the byte/bit ordering of the received length field for an IEEE 802.3-compatible frame format.

Since any valid Ethernet Type field value will always be greater than a normal IEEE 802.3 Length field (≥ 46), the Am79C978A controller will not attempt to strip valid Ethernet frames. *Note that for some network protocols, the value passed in the Ethernet Type and/or IEEE 802.3 Length field is not compliant with either standard and may cause problems if pad stripping is enabled.*

Receive FCS Checking

Reception and checking of the received FCS is performed automatically by the Am79C978A controller. Note that if the Automatic Pad Stripping feature is enabled, the FCS for padded frames will be verified against the value computed for the incoming bit stream including pad characters, but the FCS value for a padded frame will not be passed to the host. If an FCS error is detected in any frame, the error will be reported in the CRC bit in `RMD1`.

Receive Exception Conditions

Exception conditions for frame reception fall into two distinct categories, i.e., those conditions which are the result of normal network operation, and those which occur due to abnormal network and/or host related events.

Normal events which may occur and which are handled autonomously by the Am79C978A controller are basically collisions within the slot time and automatic runt packet rejection. The Am79C978A controller will ensure that collisions that occur within 512 bit times from the start of reception (excluding preamble) will be automatically deleted from the receive FIFO with no host intervention.

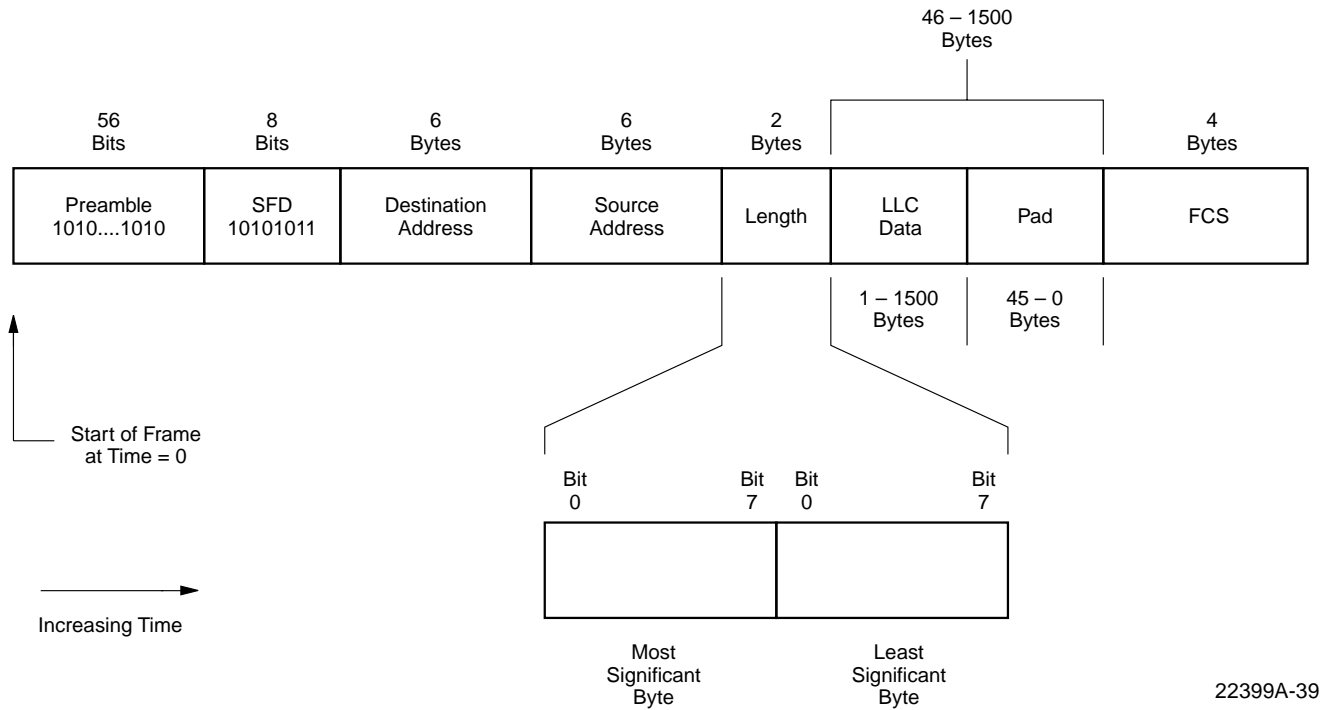

Figure 36. IEEE 802.3 Frame and Length Field Transmission Order

22399A-39

The receive FIFO will delete any frame that is composed of fewer than 64 bytes provided that the Runt Packet Accept (RPA bit in CSR124) feature has not been enabled and the network interface is operating in half-duplex mode, or the full-duplex Runt Packet Accept Disable bit (FDRPAD, BCR9, bit 2) is set. This criterion will be met regardless of whether the receive frame was the first (or only) frame in the FIFO or if the receive frame was queued behind a previously received message.

Abnormal network conditions include:

- FCS errors
- Late collision

Host related receive exception conditions include MISS, BUFF, and OFLO. These are described in the *Buffer Management Unit* section.

Loopback Operation

Loopback is a mode of operation intended for system diagnostics. In this mode, the transmitter and receiver are both operating at the same time so that the Am79C978A controller receives its own transmissions. The Am79C978A controller provides two basic types of loopback. In internal loopback mode, the transmitted data is looped back to the receiver inside the Am79C978A controller without actually transmitting any data to the external network. The receiver will move the received data to the next receive buffer, where it can be examined by software. Alternatively, in

external loopback mode, data can be transmitted to and received from the external network.

Refer to Table 30 for various bit settings required for Loopback modes.

The external loopback requires a two-step operation. The internal PHY must be placed into a loopback mode by writing to the PHY Control Register (BCR33, BCR34). Then, the Am79C978A controller must be placed into an external loopback mode by setting the Loop bits.

Miscellaneous Loopback Features

All transmit and receive function programming, such as automatic transmit padding and receive pad stripping, operates identically in loopback as in normal operation.

Runt Packet Accept is internally enabled (RPA bit in CSR124 is not affected) when any loopback mode is invoked. This is to be backwards compatible to the C-LANCE (Am79C90) software.

Since the Am79C978A controller has two FCS generators, there are no more restrictions on FCS generation or checking, or on testing multicast address detection as they exist in the half-duplex PCnet family devices and in the C-LANCE. On receive, the Am79C978A controller now provides true FCS status. The descriptor for a frame with an FCS error will have the FCS bit (RMD1, bit 27) set to 1. The FCS generator on the transmit side can still be disabled by setting DXMTFCS (CSR15, bit 3) to 1.

In internal loopback operation, the Am79C978A controller provides a special mode to test the collision logic. When FCOLL (CSR15, bit 4) is set to 1, a collision is forced during every transmission attempt. This will result in a Retry error.

Full-Duplex Operation

The Am79C978A controller supports full-duplex operation on the 10BASE-T and MII interfaces. Full-duplex operation allows simultaneous transmit and receive activity. Full-duplex operation is enabled by the FDEN bit located in BCR9. Full-duplex operation is also enabled through Auto-Negotiation when DANAS (BCR 32, bit 7) is not enabled and the ASEL bit is set, and its link partner is capable of Auto-Negotiation and full-duplex operation.

When operating in full-duplex mode, the following changes to the device operation are made:

Bus Interface/Buffer Management Unit changes:

- The first 64 bytes of every transmit frame are not preserved in the Transmit FIFO during transmission of the first 512 bits as described in the *Transmit Exception Conditions* section. Instead, when full-duplex mode is active and a frame is being transmitted, the XMTFW bits (CSR80, bits 9-8) always govern when transmit DMA is requested.
- Successful reception of the first 64 bytes of every receive frame is not a requirement for Receive DMA to begin as described in the *Receive Exception Conditions* section. Instead, receive DMA will be requested as soon as either the RCVFW threshold (CSR80, bits 12-13) is reached or a complete valid receive frame is detected, regardless of length. This Receive FIFO operation is identical to when the RPA bit (CSR124, bit 3) is set during half-duplex mode operation.

The MAC engine changes for full-duplex operation are as follows:

- Changes to the transmit deferral mechanism:
 - Transmission is not deferred while receive is active.
 - The IPG counter which governs transmit deferral during the IPG between back-to-back transmits is started when transmit activity for the first packet ends, instead of when transmit and carrier activity ends.
- The 4.0 μ s carrier sense blinding period after a transmission during which the SQE test normally occurs is disabled.
- The collision indication input to the MAC engine is ignored.

The internal PHY changes for full-duplex operation are as follows:

- The collision detect (COL) pin is disabled.
- The SQE test function is disabled.
- Loss of Carrier (LCAR) reporting is disabled.
- PHY Control Register (TBR0) bit 8 is set to 1 if Auto-Negotiation is disabled.

Full-Duplex Link Status LED Support

The Am79C978A controller provides bits in each of the LED Status registers (BCR4, BCR5, BCR6, BCR7, and BCR48) to display the Full-Duplex Link Status. If the FDLSE bit (bit 8) is set, a value of 1 will be sent to the associated LEDOUT bit when in Full-Duplex.

PHY/MAC Interface

The internal MII-compatible interface provides the data path connection between the 10BASE-T PHY, the 1 Mbps HomePNA PHY, and the 10/100 Media Access Controller (MAC). The interface is compatible with Clause 22 of the IEEE 802.3 standard specification.

10BASE-T Physical Layer

The 10BASE-T block consists of the following sub-blocks:

- Transmit Process
- Receive Process
- Interface Status
- Collision Detect Function
- Jabber Function
- Reverse Polarity Detect

Refer to Figure 37 for the 10BASE-T block diagram.

Twisted Pair Transmit Function

Data transmission over the 10BASE-T medium requires use of the integrated 10BASE-T MAU and uses the differential driver circuitry on the TX \pm pins.

TX \pm is a differential twisted-pair driver. When properly terminated, TX \pm will meet the transmitter electrical requirements for 10BASE-T transmitters as specified in IEEE 802.3, Section 14.3.1.2. The load is a twisted pair cable that meets IEEE 802.3, Section 14.4.

The TX \pm signal is filtered on the chip to reduce harmonic content per Section 14.3.2.1 (10BASE-T). Since filtering is performed in silicon, TX \pm can be connected directly to a standard transformer. External filtering modules are not needed.

Twisted Pair Receive Function

The RX \pm port is a differential twisted-pair receiver. When properly terminated, the RX \pm port will meet the electrical requirements for 10BASE-T receivers as specified in IEEE 802.3, Section 14.3.1.3. The receiver

has internal filtering and does not require external filter modules or common mode chokes.

Signals appearing at the RX± differential input pair are routed to the internal decoder. The receiver function meets the propagation delays and jitter requirements specified by the 10BASE-T standard. The receiver squelch level drops to half its threshold value after un-squelch to allow reception of minimum amplitude signals and to mitigate carrier fade in the event of worst case signal attenuation and crosstalk noise conditions.

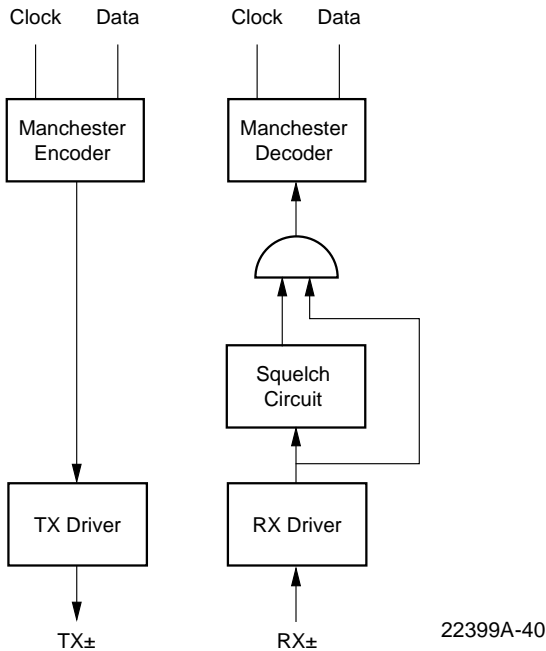

Figure 37. 10BASE-T Transmit and Receive Data Paths

Twisted Pair Interface Status

The Am79C978A device will power up in the Link Fail state. The Auto-Negotiation algorithm will apply to allow it to enter the Link Pass state.

In the Link Pass state, receive activity which passes the pulse width/amplitude requirements of the RX± inputs will cause the PCS Control block to assert Carrier Sense (CRS) signal at the internal MII interface. A collision would cause the PCS Control block to assert Carrier Sense (CRS) and Collision (COL) signals at the internal MII. In the Link Fail state, this block would cause the PCS Control block to de-assert Carrier Sense (CRS) and Collision (COL).

In jabber detect mode, this block would cause the PCS Control block to assert the COL signal at the internal MII and allow the PCS Control block to assert or de-assert the CRS pin to indicate the current state of the RX± pair. If there is no receive activity on RX±, this block

would cause the PCS Control block to assert only the COL pin at the internal MII. If there is RX± activity, this block would cause the PCS Control block to assert both COL and CRS at the internal MII.

Collision Detect Function

Simultaneous activity (presence of valid data signals) from both the internal encoder transmit function and the twisted pair RX± pins constitutes a collision, thereby causing the PCS Control block to assert the COL pin at the internal MII.

Jabber Function

The Jabber function inhibits the 10BASE-T twisted pair transmit function of the Am79C978A device if the TX± circuits are active for an excessive period (20-150 ms). This prevents one port from disrupting the network due to a *stuck-on* or faulty transmitter condition. If the maximum transmit time is exceeded, the data path through the 10BASE-T transmitter circuitry is disabled (although Link Test pulses will continue to be sent). The PCS Control block also asserts the COL signal at the internal MII and sets the Jabber Detect bit in Register 1 of the active PHY. Once the internal transmit data stream from the MENDEC stops, an *unjab* time of 250-750 ms will elapse before this block causes the PCS Control block to de-assert the COL indication and re-enable the transmit circuitry.

When jabber is detected, this block will cause the PCS Control block to assert the COL signal and allow the PCS Control block to assert or de-assert the CRS signal to indicate the current state of the RX± pair. If there is no receive activity on RX±, this block causes the PCS Control block to assert only the COL signal at the internal MII. If there is RX± activity, this block will cause the PCS Control block to assert both COL and CRS on the internal MII.

Reverse Polarity Detect

The polarity for 10BASE-T signals is set by reception of Normal Link Pulses (NLP) or packets. Polarity is locked, however, by incoming packets only. The first NLP received when trying to bring the link up will be ignored, but it will set the polarity to the correct state. The reception of two consecutive packets will cause the polarity to be locked, based on the polarity of the ETD. In order to change the polarity once it has been locked, the link must be brought down and back up again.

Auto-Negotiation

The object of the Auto-Negotiation function is to determine the abilities of the devices sharing a link. After exchanging abilities, the Am79C978A device and remote link partner device acknowledge each other and make a choice of which advertised abilities to support. The Auto-Negotiation function facilitates an ordered resolution between exchanged abilities. This

exchange allows both devices at either end of the link to take maximum advantage of their respective shared abilities.

The Am79C978A device implements the transmit and receive Auto-Negotiation algorithm as defined in IEEE 802.3u, Section 28. The Auto-Negotiation algorithm uses a burst of link pulses called Fast Link Pulses (FLPs). The burst of link pulses are spaced between 55 and 140 μ s so as to be ignored by the standard 10BASE-T algorithm. The FLP burst conveys information about the abilities of the sending device. The receiver can accept and decode an FLP burst to learn the abilities of the sending device. The link pulses transmitted conform to the standard 10BASE-T template. The device can perform auto-negotiation with reverse polarity link pulses.

The Am79C978A device uses the Auto-Negotiation algorithm to select the type connection to be established according to the following priority: 10BASE-T full duplex, then 10BASE-T half-duplex. See Table 12.

The Auto-Negotiation algorithm is initiated by the following events: Auto-Negotiation enable bit is set, hardware reset, soft reset, transition to link fail state (when Auto-Negotiation enable bit is set), or Auto-Negotiation restart bit is set. The result of the Auto-Negotiation process can be read from the status register (Summary Status Register, TBR24).

By default, the link partner must be at least 10BASE-T half-duplex capable. The Am79C978A controller can automatically negotiate with the net-

work and yield the highest performance possible without software support. See the *Network Port Manager* section for more details.

Table 12. Auto-Negotiation Capabilities

Network Speed	Physical Network Type
20 Mbps	10BASE-T, Full Duplex
10 Mbps	10BASE-T, Half Duplex

Auto-Negotiation goes further by providing a message-based communication scheme called *Next Pages* before connecting to the Link Partner. *This feature is not supported in the Am79C978A device unless the DANAS (BCR32, bit 10) is selected.*

Soft Reset Function

The PHY Control Register (TBR0) incorporates the soft reset function (bit 15). It is a read/write register and is self-clearing. Writing a 1 to this bit causes a soft reset. When read, the register returns a 1 if the soft reset is still being performed; otherwise, it is cleared to 0. *Note that the register can be polled to verify that the soft reset has terminated.* Under normal operating conditions, soft reset will be finished in 150 clock cycles.

Soft reset only resets the 10BASE-T PHY unit registers to default values (some register bits retain their previous values). Refer to the individual registers for values after a soft reset. Soft reset does not reset the management interface.

DETAILED FUNCTIONS

1 Mbps HomePNA PHY

The integrated HomePNA transceiver is a physical layer device supporting the HomePNA specification 1.1 for home phone line networking. It provides all of the PHY layer functions required to support 1 Mbps data transfer speeds over common residential phone wiring.

All data bits are encoded into the relative time position of a pulse with respect to the previous one, the waveform on the wire consists of a 7.5 MHz carrier sinusoid enclosed within an exponential (bell shaped) envelope. The waveform is produced by generating four 7.5 MHz square wave cycles and passing them through a bandpass filter.

The HomePNA PHY frame consists of a HomePNA header that replaces the normal Ethernet 64-bit preamble and delimiter and is prepended to a standard Ethernet packet starting with the source address and ending with the CRC.

Only the PHY layer and its parameters are modified from that of the standard Ethernet implementation. The HomePNA PHY layer is designed to operate with a standard Ethernet MAC layer controller implementing all the CSMA/CD protocol features.

The frame begins with a characteristic SYNC interval that delineates the beginning of a HomePNA frame followed by an Access ID (AID) which encodes 8 bits of Access ID and 4 bits of control word. The Access ID is used to detect collisions and is dynamically assigned, while the control word carries speed and power information.

The AID is followed by a silence interval, then 32 bits of data reserved for PHY layer communication. These bits are accessible via HPR20 and HPR21 and are for future use.

The data encoding consists of two symbol types: an AID symbol and a data symbol. The AID symbol is always transmitted at the same speed and encodes two bits that determine the pulse position (one of four) relative to the previous pulse. The access symbol interval is fixed.

The data symbol interval is variable. The arriving bit stream is blocked into from 3 to 6 bit blocks according to a proprietary (RLL25™) algorithm. The bits in each block are then used to encode a data symbol. Each symbol consists of a Data Inter Symbol Blanking Interval (DISBI) and then a pulse at one of 25 possible positions. The bits in the data block determine the pulse position. Immediately after the pulse a new symbol interval begins. During the DISBI the receiver ignores all incoming pulses to allow network reflections to die out.

Any station may be programmed to assume the role of a PHY master and remotely command, via the control word, the rest of the units on the network to change their transmit speed or power level.

Many of the framing parameters are programmable in the HomePNA PHY and will allow future modifications to both transmission speed as well as noise and reflection rejection algorithms.

Two default speeds are provided, low at 0.7 Mbps and high at 1 Mbps. The center frequency is also programmable for future use.

HomePNA PHY Medium Interface

Framing

The HomePNA frame on the phone wire network consists of a header generated in the PHY prepended to an IEEE 802.3 Ethernet data packet received from the MAC layer. See Figure 38.

When transmitting on the phone wire pair, the HomePNA PHY first receives an Ethernet MAC frame from the MAC. The 8 octets of preamble and delimiter are stripped off and replaced with the HomePNA PHY header described below, then transmitted on the phone wire network.

During a receive operation, the reverse process is executed. When a HomePNA frame is received by the PHY, the header is stripped off and replaced with the four octets of preamble and delimiter of the IEEE 802.3 Ethernet MAC frame specification and then passed on to the MAC layer.

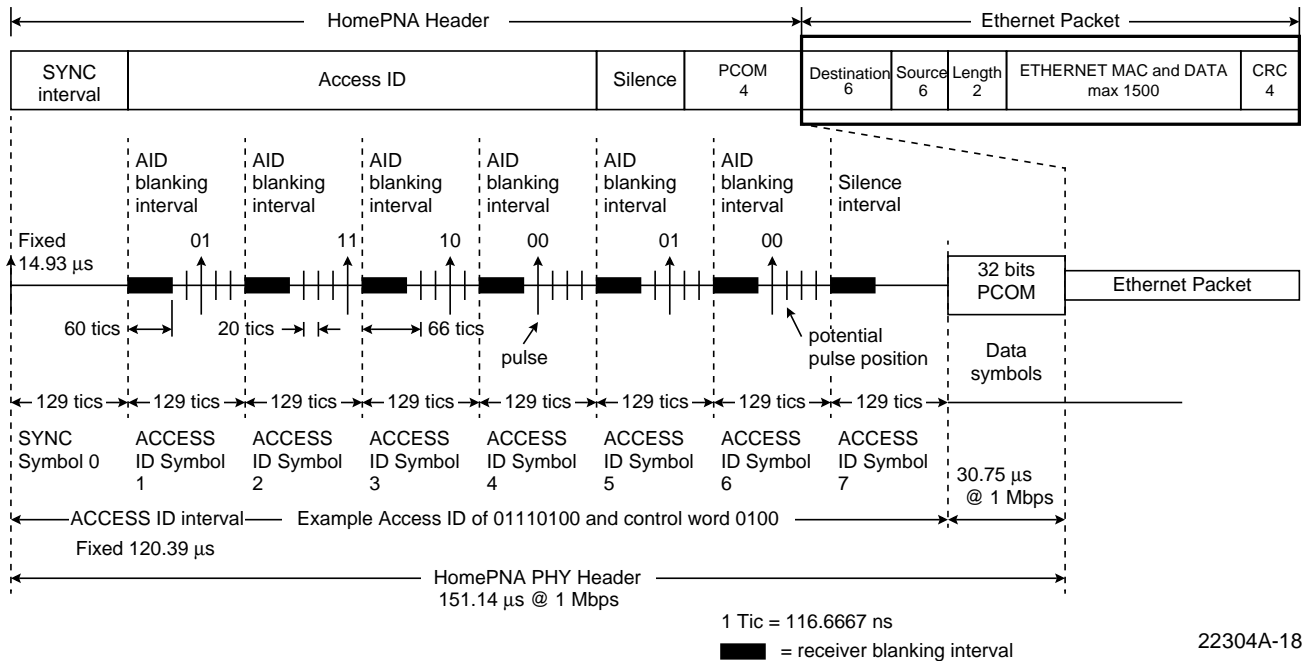

Figure 38. HomePNA PHY Framing

HomePNA Symbol Waveform

At the transmitter, all HomePNA symbols are composed of a silence interval and a pulse formed by an integer number of cycles (TX_PULSE_CYCLES_P/N in HPR29) of a square wave of frequency (CENTER_FREQUENCY TX_PULSE_WIDTH in HPR29), which has been filtered with a bandpass filter. Data is encoded in the time interval from the preceding pulse. See Table 13.

Table 13. HomePNA PHY Pulse Parameters

Parameter	Value	Tolerance	Unit
CENTER_FREQUENCY	7.5	500 PPM	MHz
CYCLES_PER_PULSE	4	–	Cycles

Time Interval Unit

HomePNA PHY time intervals are expressed in Time Interval Clock (TIC) units. One TIC is defined as 7/60E6 seconds or approximately 116.7 ns.

ACCESS ID Intervals

A HomePNA frame begins with an Access ID (AID) interval which is composed of eight equally spaced sub-intervals termed AID symbols 0 through 7 as shown in Figure 38.

An AID symbol is 129 TICs long. Transmit timing is shown in Figure 39; receive timing in Figure 40. Timing starts at the beginning of each AID symbol at TIC = 0 and ends at TIC = 129.

These symbols are described in the following sections.

Symbol 0 (SYNC interval)

SYNC Transmit Timing

The SYNC interval (AID symbol 0) delineates the beginning of a HomePNA frame and is composed of a SYNC_START pulse, followed by a SYNC_END pulse, after a fixed silence interval as shown in Figure 39. Timing for this (AID symbol 0) starts (TIC = 0) at the beginning of the SYNC_START pulse. The SYNC_END pulse starts at TIC = 126.

At TIC = 129, this AID symbol 0 ends and the next AID symbol begins, with the symbol timing reference reset to TIC = 0. No information bits are coded in the SYNC (AID symbol 0 interval).

SYNC Receive Timing

As soon as the SYNC_START pulse is detected the receiver disables (blanks) further detection until time TIC = 61, after which detection is re-enabled for the next received pulse. The receiver allows for jitter by establishing a window around each legal pulse position. This window is two TICs wide on either side of the position.

A SYNC_END pulse that arrives outside the window of the legal TIC = 126 is considered a noise event which is used in setting the adaptive squelch level, aborts the packet, and sets the receiver in search of a new SYNC_START pulse and SYNC interval. If it is a transmitting station, the COLLISION event is asserted as described in the *Collisions* section.

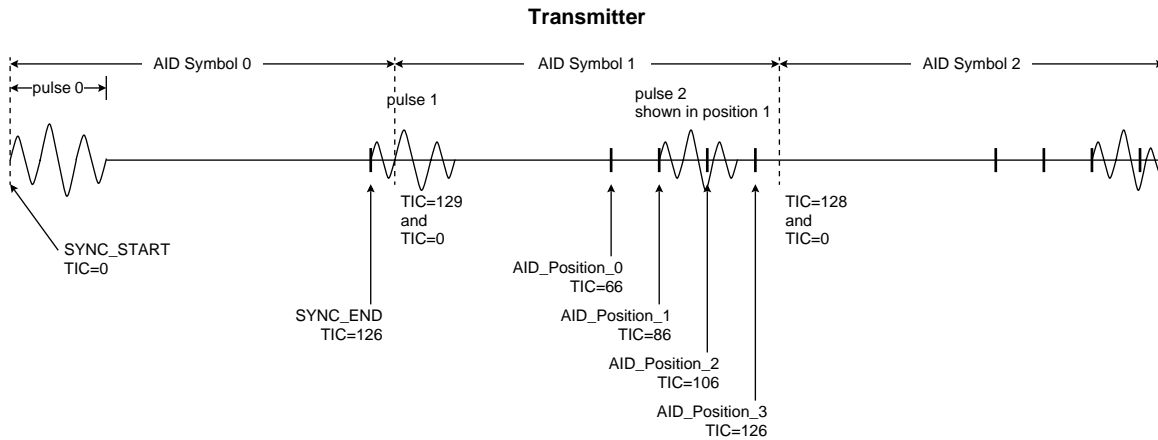

22399A-42

Figure 39. AID Symbol Transmit Timing

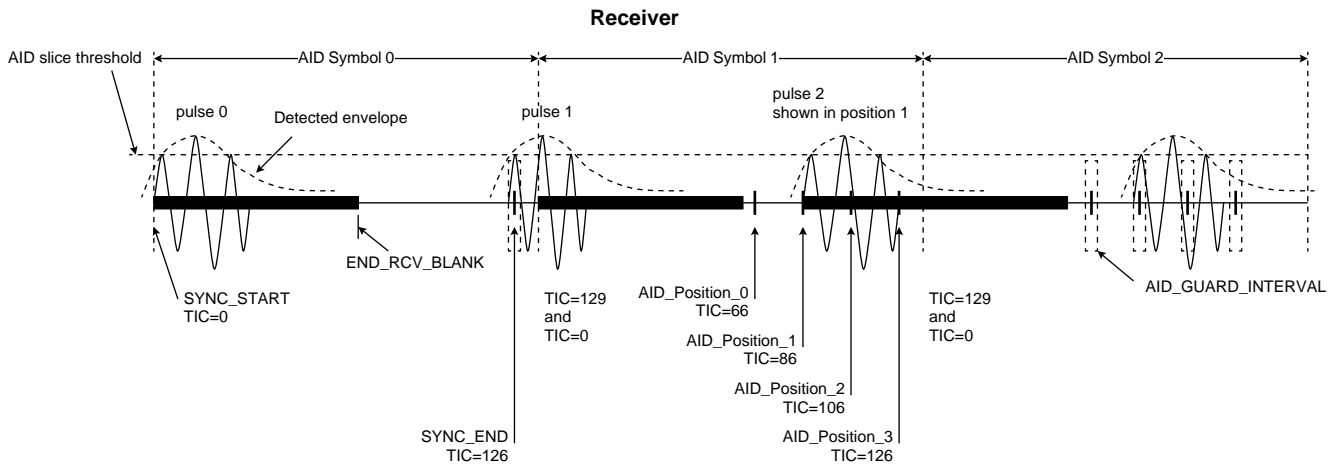

22399A-43

Figure 40. AID Symbol Receive Timing

AID Symbols 1 through 6

AID symbols 1 through 4 are used to identify individual stations to enable reliable collision detection as described in the *Collisions* section. Symbols 5 and 6 are used to transmit remote control management commands across the network. Coding and timing details are as follows.

The SYNC interval is followed by six AID symbols (symbols 1 through 6). Transmit timing is shown in Figure 39; receive timing in Figure 40. Data is encoded in the relative position of each pulse with respect to the previous one. A

pulse may occur at one, and only one, of the four possible positions within an AID symbol yielding two bits of data coded per AID symbol.

The decoded bits from the AID symbols 1 to 4 produce eight bits of Access ID which is used to identify individual HomePNA stations and to detect collisions. The MSB is encoded in AID Symbol 1 and is the leftmost bit in Table 14.

Table 14. Access ID Symbol Pulse Positions and Encoding

Pulse Position	TICs from Beginning of AID Symbol	Bit Encoding
1	66	00
2	86	01
3	106	10
4	126	11

The next two AID symbols (5 and 6) encode four bits of control word information. The MSB is encoded in AID Symbol 5. Control word messages are described further in the *Management Interfaces* section.

AID Transmit Timing

The transmitter encodes the Access ID in a pulse position in each 129 TIC interval. Each AID symbol interval must have only one pulse. Pulse transmission must start in only one of the four possible positions (measured from the beginning of the Access ID symbol) defined in Table 14.

AID Receive Timing

The receiver allows for jitter by establishing a window around each legal pulse position. This asymmetrical window is two TICS wide on one side of the position and one TIC wide on the other. A pulse that arrives outside of the legal AID positions is considered a COLLISION event.

Collisions

A Collision is detected only during Access ID and silent intervals (AID symbols 0 through 7). In general during a collision, a transmitting station will read back an AID value that does not match its own and recognizes the event as a collision and alerts other stations with a JAM signal. Non-transmitting stations may also detect some collisions by interpreting received non-conforming AID pulses as collisions.

With two transmitters colliding, each transmitter normally blanks its receive input immediately after transmitting (and simultaneously receiving) a pulse. Therefore, only when a transmitting station receives pulses in a position earlier than the position it transmitted will it recognize it as a pulse transmitted by another station and signal a collision.

For this reason, guaranteed collision detection is possible only as long as the spacing between successive possible pulse positions in an AID symbol (20 TICs or 2.3 μ s) is greater than the round trip delay between the colliding nodes. At approximately 1.5 ns propagation delay per foot, the maximum distance between two HomePNA units must not be greater than 500 feet for collision detection purposes (1.5 μ s round trip delay plus margin).

The following criteria must be met to guarantee reliable collision detection:

At least one HomePNA station of a colliding group must always detect a collision when the delay between the beginning of its transmitted packet and the beginning of the received colliding packet is between -1.5 μ s and +1.5 μ s.

In general, any received pulse at a HomePNA station that does not conform to the pulse position requirements of AID symbols 0 through 7 shall indicate a collision on the wire. When a transmitting station senses a collision, it emits a JAM signal to alert all other stations to the collision. The following conditions signify a COLLISION event:

1. A HomePNA station receives an AID that does not match the one being sent.
2. A HomePNA station receives a pulse outside the AID_GUARD INTERVAL in AID intervals 0 to 7.
3. A HomePNA station receives a pulse inside the SILENT_INTERVAL (AID symbol 7).

As in all cases, pulses received during a blanking interval are ignored.

Passive stations (stations not actively transmitting during the collision) cannot reliably detect collisions. Therefore, once a collision is detected by a transmitting station, the station must inform the rest of the stations of the collision with a JAM pattern described below. Only a transmitting station emits a JAM signal.

Once a collision is detected, the COLLISION signal to the MAC interface is asserted and is not reset until the MAC deactivates the TXEN signal.

JAM Signal

A JAM pattern consists of one pulse every 32 TICs and continues until at least the end of the AID intervals. After the AID interval, the JAM pattern will continue until TXEN from the MAC is deactivated.

ACCESS ID Values

The access ID values for slave stations are picked by each individual station randomly from the set of AID slave numbers described in the management section. During operation, each HomePNA station monitors HomePNA frames received on the wire. If it detects another HomePNA station using the same AID, it will select a new random AID.

Silence Interval (AID symbol 7)

The Access ID symbols are followed by a fixed silence interval of 129 TICs. The receive blanking interval is the same as that of the AID symbols (1 through 6).

Any pulses detected in the silence interval are considered a COLLISION event for transmitting stations and are handled as described in the *Collisions* section.

Data Symbols

Data symbols encode data for a much higher transmission rate, and they do not allow collision detection.

Data Transmit Timing

A data symbol interval begins with the beginning of transmission of a pulse as shown in Figure 41. Transmit Symbol timing (in TICS) is measured from this point (TIC = 0).

Depending on the data code, the next pulse may begin at any PULSE_POSITION_N where N = 0 to 24. Each position is separated from the previous one by one TIC.

PULSE_POSITION_0 occurs at a value defined in Table 15 which determines the transmission speed. When a pulse begins transmission, the previous symbol interval ends and a new one begins immediately.

Table 15. Blanking Interval Speed Settings

Speed Setting	Nominal Data Rate	PULSE_POSITION_0 Value (in TICs)
LOW_SPEED	0.7 Mbps	44
HIGH_SPEED	1.0 Mbps	28

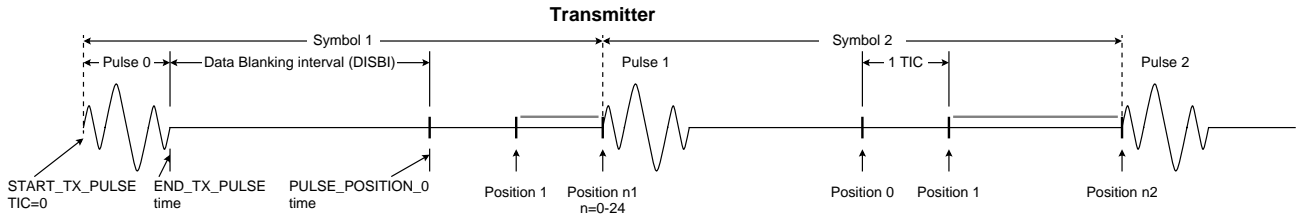

22399A-44

Figure 41. Transmit Data Symbol Timing

Data Receive Timing

The incoming waveform is formed from the transmitted pulse. The receiver detects the point at which the envelope of the received waveform crosses a set threshold. See Figure 42.

Immediately after the threshold crossing, the receiver disables any further detection for a period ISBI-3 TICs (HPR28 ISBI_SLOW or ISBI_FAST) starting with the detection of the pulse peak.

The receiver is then re-enabled for pulse detection. Upon reception of the next pulse, the receiver measures the elapsed time from the previous pulse. This value is then placed in the nearest pulse position bin (one of 25) where pulse position 0 is at PULSE_POSITION_0 and each subsequent position is spaced one TIC from the previous one as defined in the *Data Transmit Timing* section. Data symbol intervals are therefore variable and depend on the encoded data.

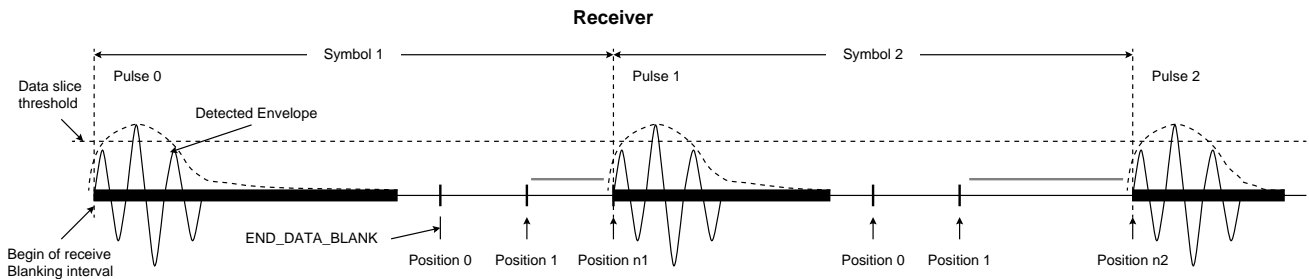

22399A-45

Figure 42. Receive Symbol Timing

Data Symbol RLL25 Encoding

The RLL25 code is the version of TM32 that was developed for the HomePNA PHY. It produces both the highest bit rate for a given value of ISBI and TIC size. In a manner similar to run length limited disk coding, RLL25 encodes data bits in groups of varying sizes, specifically: 4, 5, 6, and 7 bits. Pulse positions are assigned to the encoded bit groups in a manner, which causes more data bits to be encoded in positions that are farther apart. This keeps both the average and minimum bit rates higher.

Data symbol RLL25 codes data by traversing a tree as illustrated in Figure 43. Assume that successive data bits to be encoded are labeled A, B, C, D, ..., etc. The encoding process begins at the root node and proceeds as follows:

1. If the first bit (bit A) is a one, the next three bits (B, C, and D) select which one of the eight positions 1-8 is transmitted. The encoding process then continues at the root node.
2. If bit A is a zero and bit B is a one, the next three bits (C, D, and E) select which one of the eight positions 9-16 is transmitted. The encoding process then continues at the root node.

3. If bit A is a zero, bit B is a zero, and bit C is a one, the next three bits (D, E, and F) select which one of the eight positions 17-24 is transmitted. The encoding process then continues at the root node.
4. Finally, if bits A, B, and C are all zeros, position 0 is transmitted. The encoding process then continues at the root node.

As a result, Symbol 0 encodes the 3-bit data pattern 000, positions 1-8 encode the 4-bit data pattern 1BCD, positions 9-16 encode the 5-bit data pattern 01CDE, and positions 17-24 encode the 6-bit data pattern 001DEF. If the data encoded is random, 50% of the positions used will be for 4-bit patterns, 25% will be for 5-bit patterns, 12.5% will be for 6-bit patterns, and 12.5% will be for 3-bit patterns.

Management Interfaces

The HomePNA PHY may be managed from either of two interfaces (the managed parameters vary depending on the interface):

1. Remote Control-Word management commands embedded in the HomePNA AID header on the wire network.
2. Management messages from a local management entity.

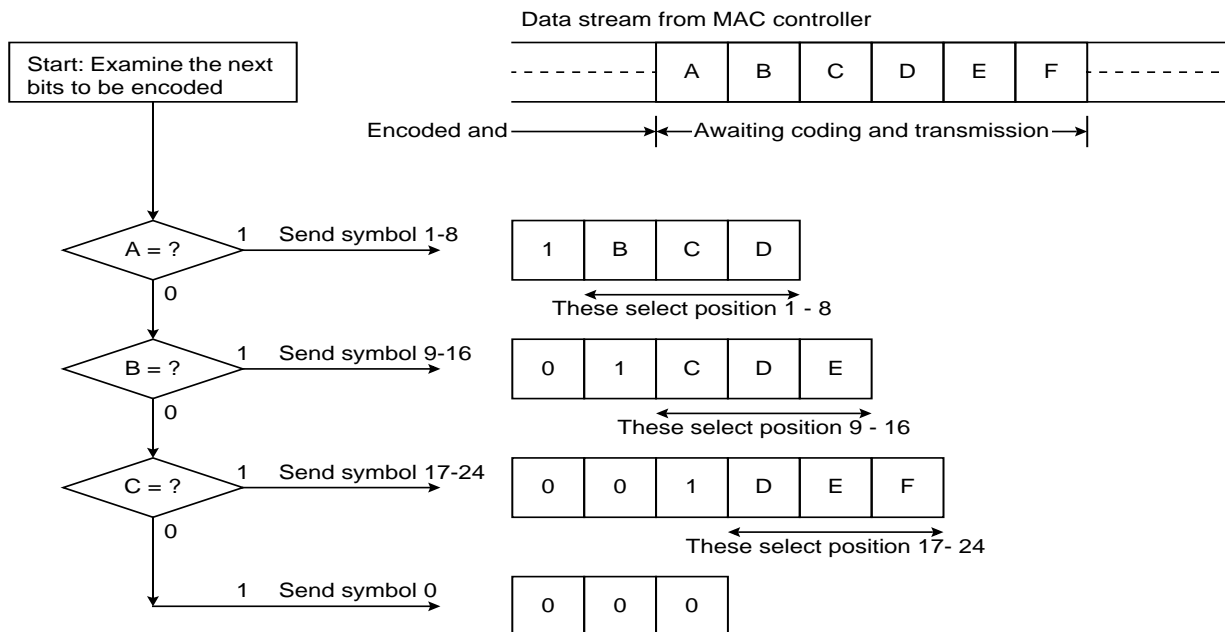

22399A-46

Figure 43. RLL 25 Coding Tree

Header AID Remote Control Word Commands

Stations may be configured either as master stations or as slave stations. Only one master may exist on a given HomePNA segment.

The master station may send commands embedded in the HomePNA header control word to remotely set various parameters of the remote slave stations. Stations are identified via the AID as follows:

1. The master station is identified on the HomePNA wire network with an AID of FFh.
2. A slave is identified with an AID of 00h to EFh.
3. AID values of F0h to FEh are reserved for future use.

Once a command has been transmitted, the master station will revert to a slave AID, so that subsequent control words are not interpreted as new commands.

Master mode is entered by writing to the PHY control register (HPR16) and is exited upon the completion of the command sequence.

A valid master remote command consists of three HomePNA frames with an AID of FFh. Since the HomePNA header is prepended to packets received from the MAC, packets from the master station may be separated by intervals during which other (slave) stations may transmit their frames.

A remote master Control Word command must be recognized and executed by a HomePNA PHY when it receives three consecutive valid HomePNA frames with an AID of FFh.

If HPR16, bit 15 is not set to 0, valid commands are as follows:

1. SET_POWER: Commands slave stations to set their transmit level to a prescribed level.
2. SET_SPEED: Commands slave stations to set their transmit speed to a prescribed value.

The control word bit encoding and possible values are described in Table 16.

Table 16. Master Station Control Word Functions

Bit No.	Command Function
0	0 = version 0 (All stations revert to version 0 HomePNA PHY mode of operation).
1	0 = Set transmit to low speed. 1 = Set transmit to high speed.
2	0 = Set to low power transmit mode. 1 = Set to high power transmit mode.
3	Reserved

All stations will transmit the following status messages in the HomePNA header control word of all outgoing frames:

1. VERSION_STATUS: The HomePNA PHY version of the slave station.
2. POWER_STATUS: The transmit power level of the transmitting slave station for the current frame. All HomePNA units support LOW_POWER and HIGH_POWER modes.
3. SPEED_STATUS: The transmit speed of the slave station for the current frame. Receiving stations will adjust their receiver parameters to correctly interpret this frame.

The slave control word bit encoding and possible values are described in Table 17.

Table 17. Slave Station Control Word Status Conditions

Bit #	Indicated Status
0	0 = This station is version 0. 1 = This station is not version 0.
1	0 = Frame transmitted at low speed. 1 = Frame transmitted at high speed.
2	0 = Frame transmitted at low power. 1 = Frame transmitted at high power.
3	Reserved

PHY Control and Management Block (PCM Block)

Register Administration for 10BASE-T PHY Device

The management interface specified in Clause 22 of the IEEE 802.3u standard provides for a simple two wire, serial interface to connect a management entity and a managed PHY for the purpose of controlling the PHY and gathering status information. The two lines are Management Data Input/Output (MDIO) and Management Data Clock (MDC). A station management entity which is attached to multiple PHY entities must have prior knowledge of the appropriate PHY address for each PHY entity.

Description of the Methodology

The management interface physically transports management information across the internal MII. The information is encapsulated in a frame format as specified in Clause 22 of the IEEE 802.3u draft standard and is shown in Table 18.

Table 18. MII Control Frame Format

	PRE	ST	OP	PHYAD	REGAD	TA	DATA	IDLE
READ	1.1	01	10	AAAAA	RRRRR	Z0	D31.....D0	Z
WRITE	1.1	01	01	AAAAA	RRRRR	10	D31.....D0	Z

The start field (ST) is followed by the operation field (OP). The operation field (OP) indicates whether the operation is a read or a write operation. This is followed by the PHY address (PHYAD) and the register address (REGAD) that was programmed into BCR33 of the Fast Ethernet controller. This field is followed by a bus turnaround field (TA). During the read operation, the bus turnaround field is used to determine if the PHY is responding properly to the read request. The data field to/from the MAC controller is then written to or read from BCR34. The final field is the idle field, and it is required to allow the drivers to turn off.

The PHYADD field, which is five bits wide, allows 32 unique PHY addresses. The managed PHY layer device that is connected to a station management entity via the MII interface has to respond to transactions addressed to the PHY's address. A station management entity attached to multiple PHYs is required to have prior knowledge of the appropriate PHY address.

No SRAM Configuration

If the SRAM_SIZE (BCR25, bits 7-0) value is 0 in the SRAM size register, the controller will assume that there is no SRAM present and will reconfigure the four internal FIFOs into two FIFOs, one for transmit and one for receive. The FIFOs will operate the same as in the PCnet-PCI II controller. When the SRAM_SIZE (BCR25, bits 7-0) value is 0, the SRAM_BND (BCR26, bits 7-0) are ignored by the controller. See Figure 44.

Low Latency Receive Configuration

If the LOLATRX (BCR27, bit 4) bit is set to 1, then the controller will configure itself for a low latency receive configuration. In this mode, SRAM is required at all times. If the

SRAM_SIZE (BCR25, bits 7-0) value is 0, the controller will not configure for low latency receive mode. The controller will provide a fast path on the receive side bypassing the SRAM. All transmit traffic will go to the SRAM, so SRAM_BND (BCR26, bits 7-0) has no meaning in low latency receive mode. When the controller has received 16 bytes from the network, it will start a DMA request to the PCI Bus Interface Unit. The controller will not wait for the first 64 bytes to pass to check for collisions in Low Latency Receive mode. The controller must be in STOP before switching to this mode. See Figure 45.

CAUTION: To provide data integrity when switching into and out of the low latency mode, DO NOT SET the FASTSPNDE bit when setting the SPND bit. Receive frames WILL be overwritten and the controller may give erratic behavior when it is enabled again.

Direct SRAM Access

The SRAM can be accessed through the Expansion Bus Data port (BCR30). To access this data port, the user must load the upper address EPADDRU (BCR29, bits 3-0) and set FLASH (BCR29, bit 15) to 0. Then the user will load the lower 16 bits of address EPADDRL (BCR28, bits 15-0). To initiate a read, the user reads the Expansion Bus Data Port (BCR30). This slave access from the PCI will result in a retry for the very first access. Subsequent accesses may give a retry or not, depending on whether or not the data is present and valid. The direct SRAM access uses the same FLASH/EPROM access except for accessing the SRAM in word format instead of byte format. This access is meant to be a diagnostic access only. The SRAM can only be accessed while the controller is in STOP or SPND (FASTSPNDE is set to 0) mode.

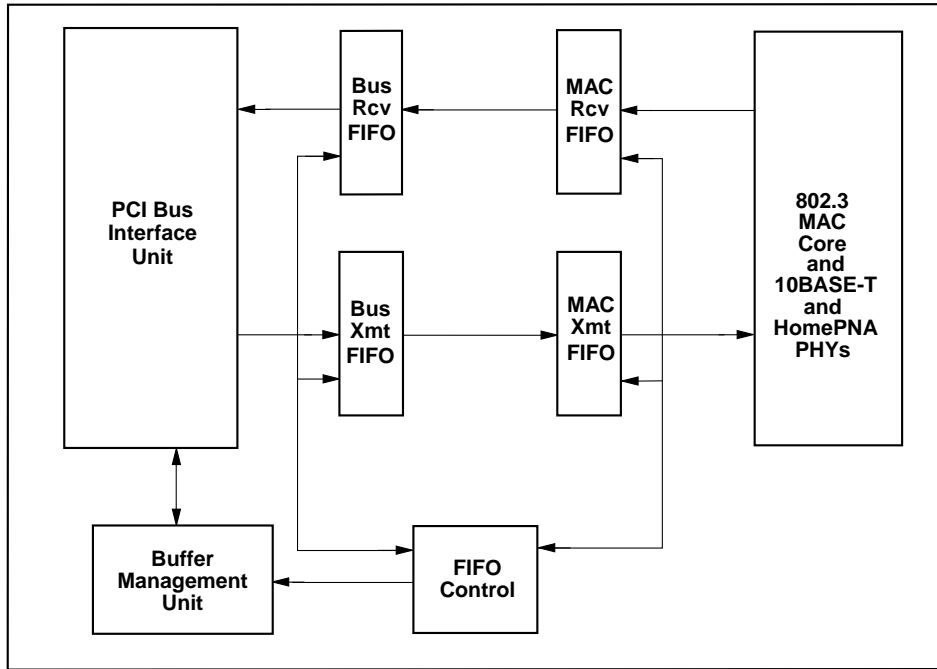

22399A-47

Figure 44. Block Diagram No SRAM Configuration

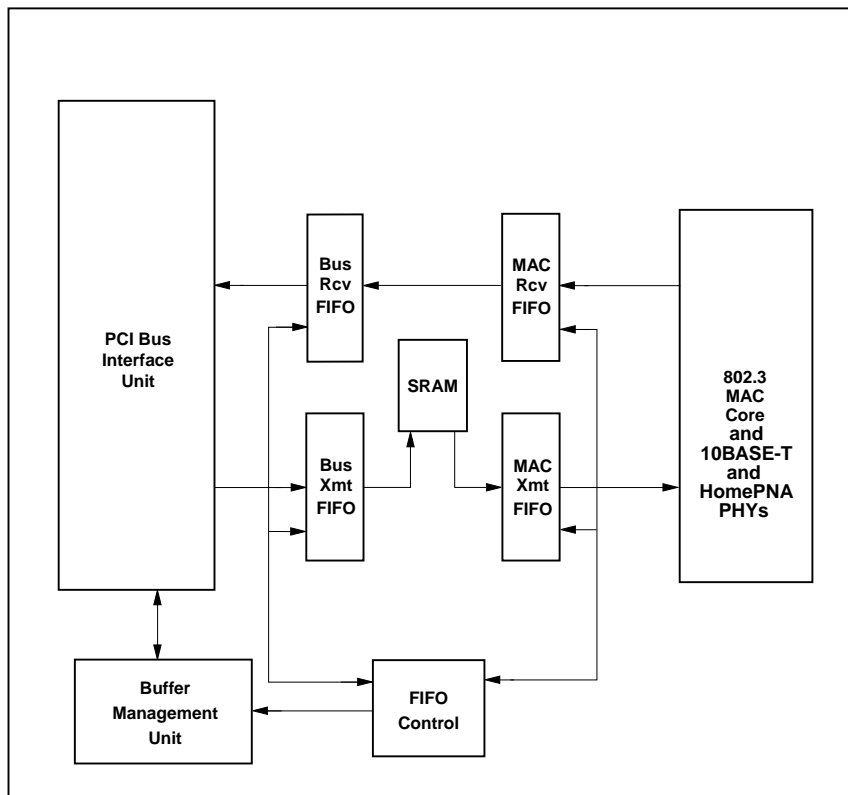

22399A-48

Figure 45. Block Diagram Low Latency Receive Configuration

EEPROM Interface

The controller contains a built-in capability for reading and writing to an external serial 93C46 EEPROM. This built-in capability consists of an interface for direct connection to a 93C46 compatible EEPROM, an automatic EEPROM read feature, and a user-programmable register that allows direct access to the interface pins.

Automatic EEPROM Read Operation

Shortly after the deassertion of the \overline{RST} pin, the controller will read the contents of the EEPROM that is attached to the interface. Because of this automatic-read capability of the controller, an EEPROM can be used to program many of the features of the controller at power-up, allowing system-dependent configuration information to be stored in the hardware instead of inside the device driver.

If an EEPROM exists on the interface, the controller will read the EEPROM contents at the end of the H_RESET operation. The EEPROM contents will be serially shifted into a temporary register and then sent to various register locations on board the controller. Access to the Am79C978A configuration space, the Expansion ROM, or any I/O resource is not possible during the EEPROM read operation. The controller will terminate any access attempt with the assertion of \overline{DEVSEL} and \overline{STOP} while \overline{TRDY} is not asserted, signaling to the initiator to disconnect and retry the access at a later time.

A checksum verification is performed on the data that is read from the EEPROM. If the checksum verification passes, PVALID (BCR19, bit 15) will be set to 1. If the checksum verification of the EEPROM data fails, PVALID will be cleared to 0, and the controller will force all EEPROM-programmable BCR registers back to their H_RESET default values. However, the content of the Address PROM locations (offsets 0h - Fh from the I/O or memory mapped I/O base address) will not be cleared. The 8-bit checksum for the entire 82 bytes of the EEPROM should be FFh.

If no EEPROM is present at the time of the automatic read operation, the controller will recognize this condition, abort the automatic read operation, and clear both the PREAD and PVALID bits in BCR19. All EEPROM-programmable BCR registers will be assigned their default values after H_RESET. The content of the Address PROM locations (offsets 0h - Fh from the I/O or memory mapped I/O base address) will be undefined.

EEPROM Auto-Detection

The controller uses the EESK/ $\overline{LED1}$ pin to determine if an EEPROM is present in the system. At the rising edge of CLK during the last clock during which \overline{RST} is asserted, the controller will sample the value of the EESK/ $\overline{LED1}$ pin. If the sampled value is a 1, then the controller assumes that an EEPROM is present, and the EEPROM read operation begins shortly after the \overline{RST} pin is deasserted. If the sampled value of EESK/ $\overline{LED1}$ is a 0,

the controller assumes that an external pull-down device is holding the EESK/ $\overline{LED1}$ pin low, indicating that there is no EEPROM in the system. Note that if the designer creates a system that contains an LED circuit on the EESK/ $\overline{LED1}$ pin, but has no EEPROM present, then the EEPROM auto-detection function will incorrectly conclude that an EEPROM is present in the system. However, this will not pose a problem for the controller, since the checksum verification will fail.

Direct Access to the Interface

The user may directly access the port through the EEPROM register, BCR19. This register contains bits that can be used to control the interface pins. By performing an appropriate sequence of accesses to BCR19, the user can effectively write to and read from the EEPROM. This feature may be used by a system configuration utility to program hardware configuration information into the EEPROM.

EEPROM-Programmable Registers

The following registers contain configuration information that will be programmed automatically during the EEPROM read operation:

- I/O offsets 0h-Fh Address PROM locations
- BCR2 Miscellaneous Configuration
- BCR4 LED0 Status
- BCR5 LED1 Status
- BCR6 LED2 Status
- BCR7 LED3 Status
- BCR9 Full-Duplex Control
- BCR18 Burst and Bus Control
- BCR22 PCI Latency
- BCR23 PCI Subsystem Vendor ID
- BCR24 PCI Subsystem ID
- BCR25 SRAM Size
- BCR26 SRAM Boundary
- BCR27 SRAM Interface Control
- BCR32 PHY Control and Status
- BCR33 PHY Address
- BCR35 PCI Vendor ID
- BCR36 PCI Power Management Capabilities (PMC) Alias Register
- BCR37 PCI DATA Register 0 (DATA0) Alias Register
- BCR38 PCI DATA Register 1 (DATA1) Alias Register
- BCR39 PCI DATA Register 2 (DATA2) Alias Register

- BCR40 PCI DATA Register 3 (DATA3) Alias Register
- BCR41 PCI DATA Register 4 (DATA4) Alias Register
- BCR42 PCI DATA Register 5 (DATA5) Alias Register
- BCR43 PCI DATA Register 6 (DATA6) Alias Register
- BCR44 PCI DATA Register 7 (DATA7) Alias Register
- BCR45 OnNow Pattern Matching Register 1
- BCR46 OnNow Pattern Matching Register 2
- BCR47 OnNow Pattern Matching Register 3
- BCR48 LED4 Status
- BCR49 PHY Select
- CRS12 Physical Address Register 0
- CRS13 Physical Address Register 1
- CRS14 Physical Address Register 2
- CSR116 OnNow Miscellaneous

If PREAD (BCR19, bit 14) and PVALID (BCR19, bit 15) are cleared to 0, then the EEPROM read has experienced a failure and the contents of the EEPROM programmable BCR register will be set to default H_RESET values. The content of the Address PROM locations, however, will not be cleared.

EEPROM MAP

The automatic EEPROM read operation will access 41 words (i.e., 82 bytes) of the EEPROM. The format of the EEPROM contents is shown in Table 19, beginning with the byte that resides at the lowest EEPROM address.

CAUTION: *The first bit out of any word location in the EEPROM is treated as the MSB of the register being programmed. For example, the first bit out of EEPROM word location 09h will be written into BCR4, bit 15; the second bit out of EEPROM word location 09h will be written into BCR4, bit 14, etc.*

There are two checksum locations within the EEPROM. The first checksum will be used by AMD driver software to verify that the ISO 8802-3 (IEEE/ANSI 802.3) station address has not been corrupted. The value of bytes 0Ch and 0Dh should match the sum of bytes 00h through 0Bh and 0Eh and 0Fh. The second checksum location (byte 51h) is not a checksum total, but is, instead, a checksum adjustment. The value of this byte should be such that the total checksum for the entire 82 bytes of EEPROM data equals the value FFh. The checksum adjust byte is needed by the controller in order to verify that the EEPROM content has not been corrupted.

LED Support

The controller can support up to five LEDs. LED outputs $\overline{\text{LED0}}$, $\overline{\text{LED1}}$, $\overline{\text{LED2}}$, $\overline{\text{LED3}}$, and $\overline{\text{LED4}}$ allow for direct connection of an LED and its supporting pull-up device.

In applications that want to use the pin to drive an LED and also have an EEPROM, it might be necessary to buffer the $\overline{\text{LED3}}$ circuit from the EEPROM connection. When an LED circuit is directly connected to the EEDO/ $\overline{\text{LED3}}$ pin, then it is not possible for most EEPROM devices to sink enough I_{OL} to maintain a valid low level on the EEDO input to the controller. Use of buffering can be avoided if a low power LED is used.

Each LED can be programmed through a BCR register to indicate one or more of the following network status or activities: Collision Status, Full-Duplex Link Status, Half-Duplex Link Status, Receive Match, Receive Status, Magic Packet, Disable Transceiver, Transmit Status, Power, and Speed.

Table 19. EEPROM Map

Word Address	Byte Addr.	Most Significant Byte	Byte Addr.	Least Significant Byte
00h*	01h	2nd byte of the ISO 8802-3 (IEEE/ANSI 802.3) station physical address for this node	00h	First byte of the ISO 8802-3 (IEEE/ANSI 802.3) station physical address for this node, where "first byte" refers to the first byte to appear on the 802.3 medium
01h	03h	4th byte of the node address	02h	3rd byte of the node address
02h	05h	6th byte of the node address	04h	5th byte of the node address
03h	07h	CSR116[15:8] (OnNow Misc. Configuration)	06h	CSR116[7:0] (OnNow Misc. Configuration)
04h	09h	Hardware ID: must be 11h if compatibility to AMD drivers is desired	08h	Reserved location: must be 00h
05h	0Bh	User programmable space	0Ah	User programmable space
06h	0Dh	MSB of two-byte checksum, which is the sum of bytes 00h-0Bh and bytes 0Eh and 0Fh	0Ch	LSB of two-byte checksum, which is the sum of bytes 00h-0Bh and bytes 0Eh and 0Fh
07h	0Fh	Must be ASCII "W" (57h) if compatibility to AMD driver software is desired	0Eh	Must be ASCII "W" (57h) if compatibility to AMD driver software is desired
08h	11h	BCR2[15:8] (Miscellaneous Configuration)	10h	BCR2[7:0] (Miscellaneous Configuration)
09h	13h	BCR4[15:8] (Link Status LED)	12h	BCR4[7:0] (Link Status LED)
0Ah	15h	BCR5[15:8] (LED1 Status)	14h	BCR5[7:0] (LED1 Status)
0Bh	17h	BCR6[15:8] (LED2 Status)	16h	BCR6[7:0] (LED2 Status)
0Ch	19h	BCR7[15:8] (LED3 Status)	18h	BCR7[7:0] (LED3 Status)
0Dh	1Bh	BCR9[15:8] (Full-Duplex control)	1Ah	BCR9[7:0] (Full-Duplex Control)
0Eh	1Dh	BCR18[15:8] (Burst and Bus Control)	1Ch	BCR18[7:0] (Burst and Bus Control)
0Fh	1Fh	BCR22[15:8] (PCI Latency)	1Eh	BCR22[7:0] (PCI Latency)
10h	21h	BCR23[15:8] (PCI Subsystem Vendor ID)	20h	BCR23[7:0] (PCI Subsystem Vendor ID)
11h	23h	BCR24[15:8] (PCI Subsystem ID)	22h	BCR24[7:0] (PCI Subsystem ID)
12h	25h	BCR25[15:8] (SRAM Size)	24h	BCR25[7:0] (SRAM Size)
13h	27h	BCR26[15:8] (SRAM Boundary)	26h	BCR26[7:0] (SRAM Boundary)
14h	29h	BCR27[15:8] (SRAM Interface Control)	28h	BCR27[7:0] (SRAM Interface Control)
15h	2Bh	BCR32[15:8] (MII Control and Status)	2Ah	BCR32[7:0] (MII Control and Status)
16h	2Dh	BCR33[15:8] (MII Address)	2Ch	BCR33[7:0] (MII Address)
17h	2Fh	BCR35[15:8] (PCI Vendor ID)	2Eh	BCR35[7:0] (PCI Vendor ID)
18h	31h	BCR36[15:8] (Conf. Space. byte 43h alias)	30h	BCR36[7:0] (Conf. Space byte 42h alias)
19h	33h	BCR37[15:8] (DATA_SCALE alias 0)	32h	BCR37[7:0] (Conf. Space byte 47h0alias)
1Ah	35h	BCR38[15:8] (DATA_SCALE alias 1)	34h	BCR38[7:0] (Conf. Space byte 47h1alias)
1Bh	37h	BCR39[15:8] (DATA_SCALE alias 2)	36h	BCR39[7:0] (Conf. Space byte 47h2alias)
1Ch	39h	BCR40[15:8] (DATA_SCALE alias 3)	38h	BCR40[7:0] (Conf. Space byte 47h3alias)
1Dh	3Bh	BCR41[15:8] (DATA_SCALE alias 4)	3Ah	BCR41[7:0] (Conf. Space byte 47h4alias)
1Eh	3Dh	BCR42[15:8] (DATA_SCALE alias 0)	3Ch	BCR42[7:0] (Conf. Space byte 47h5alias)
1Fh	3Fh	BCR43[15:8] (DATA_SCALE alias 0)	3Eh	BCR43[7:0] (Conf. Space byte 47h6alias)
20h	41h	BCR44[15:8] (DATA_SCALE alias 0)	40h	BCR44[7:0] (Conf. Space byte 47h7alias)
21h	43h	BCR48[15:8] (LED4 Status)	42h	BCR48[7:0] (LED4 Status)
22h	45h	BCR49[15:8] (PHY Select)	44h	BCR49[7:0] (PHY Select)
23h	47h	BCR50[15:8]Reserved location: must be 00h	46h	BCR50[7:0]Reserved location: must be 00h
24h	49h	BCR51[15:8]Reserved location: must be 00h	48h	BCR51[7:0]Reserved location: must be 00h
25h	4Bh	BCR52[15:8]Reserved location: must be 00h	4Ah	BCR52[7:0]Reserved location: must be 00h
26h	4Dh	BCR53[15:8]Reserved location: must be 00h	4Ch	BCR53[7:0]Reserved location: must be 00h
27h	4Fh	BCR54[15:8]Reserved location: must be 00h	4Eh	BCR54[7:0]Reserved location: must be 00h
28h	51h	Checksum adjust byte for the 82 bytes of the EEPROM contents, checksum of the 82 bytes of the EEPROM should total to FFh	50h	BCR54[7:0]Reserved location: must be 00h
Empty locations – Ignored by device				
3Eh	7Dh	Reserved	7Ch	Reserved
3Fh	7Fh	Reserved	7Eh	Reserved

CAUTION: *Lowest EEPROM address.

The LED pins can be configured to operate in either open-drain mode (active low) or in totem-pole mode (active high). The output can be stretched to allow the human eye to recognize even short events that last only several microseconds. After H_RESET, the five LED outputs are configured as shown in Table 20.

Table 20. LED Default Configuration

LED Output	Indication	Driver Mode	Pulse Stretch
LED0	Link Status	Open Drain - Active Low	Enabled
LED1	Receive Status	Open Drain - Active Low	Enabled
LED2	Power	Open Drain - Active Low	Enabled
LED3	Transmit Status	Open Drain - Active Low	Enabled
LED4	Speed	Open Drain - Active Low	Enabled

For each LED register, each of the status signals is AND'd with its enable signal, and these signals are all OR'd together to form a combined status signal. Each LED pin combined status signal can be programmed to run to a pulse stretcher, which consists of a 3-bit shift register clocked at 38 Hz (26 ms). The data input of each shift register is normally at logic 0. The OR gate output for each LED register asynchronously sets all three bits of its shift register when the output becomes asserted. The inverted output of each shift register is used to control an LED pin. Thus, the pulse stretcher provides two to three clocks of stretched LED output, or 52 ms to 78 ms. See Figure 46.

Power Savings Mode

Power Management Support

The controller supports power management as defined in the PCI Bus Power Management Interface Specification V1.1 and Network Device Class Power Management Reference Specification V1.0a. These specifications define the network device power states, PCI power management interface including the Capabilities Data Structure and power management registers block definitions, power management events, and OnNow network wake-up events.

The general scheme for the Am79C978A power management is that when a PCI wake-up event is detected, a signal is generated to cause hardware external to the Am79C978A device to put the computer into the working (S0) mode.

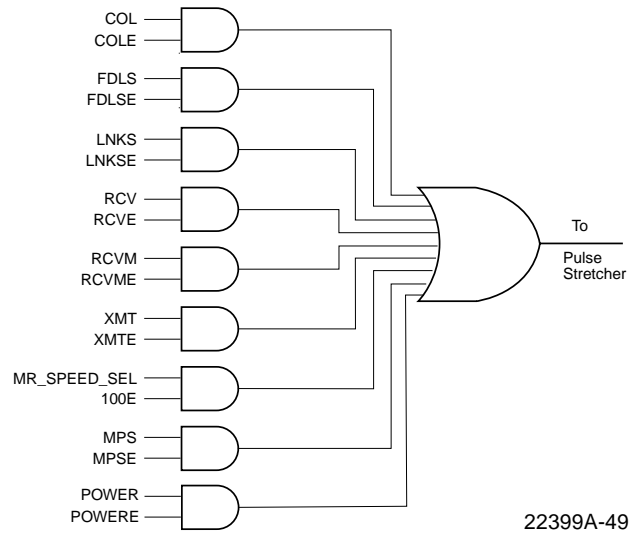

Figure 46. LED Control Logic

The Am79C978A device supports three types of wake-up events:

1. Magic Packet Detect
2. OnNow Pattern Match Detect
3. Link State Change

Figure 47 shows the relationship between these wake-up events and the various outputs used to signal to the external hardware.

OnNow Wake-Up Sequence

The system software enables the $\overline{\text{PME}}$ pin by setting the PME_EN bit in the PMCSR register (PCI configuration registers, offset 44h, bit 8) to 1. When a wake-up event is detected, the controller sets the PME_STATUS bit in the PMCSR register (PCI configuration registers, offset 44h, bit 15). Setting this bit causes the $\overline{\text{PME}}$ signal to be asserted. Assertion of the $\overline{\text{PME}}$ signal causes external hardware to wake up the CPU. The system software then reads the PMCSR register of every PCI device in the system to determine which device asserted the $\overline{\text{PME}}$ signal.

When the software determines that the signal came from the controller, it writes to the device's PMCSR to put the device into power state D0. The software then writes a 0 to the PME_STATUS bit to clear the bit and turn off the $\overline{\text{PME}}$ signal, and it calls the device's software driver to tell it that the device is now in state D0. The system software can clear the PME_STATUS bit either before, after, or at the same time that it puts the device back into the D0 state.

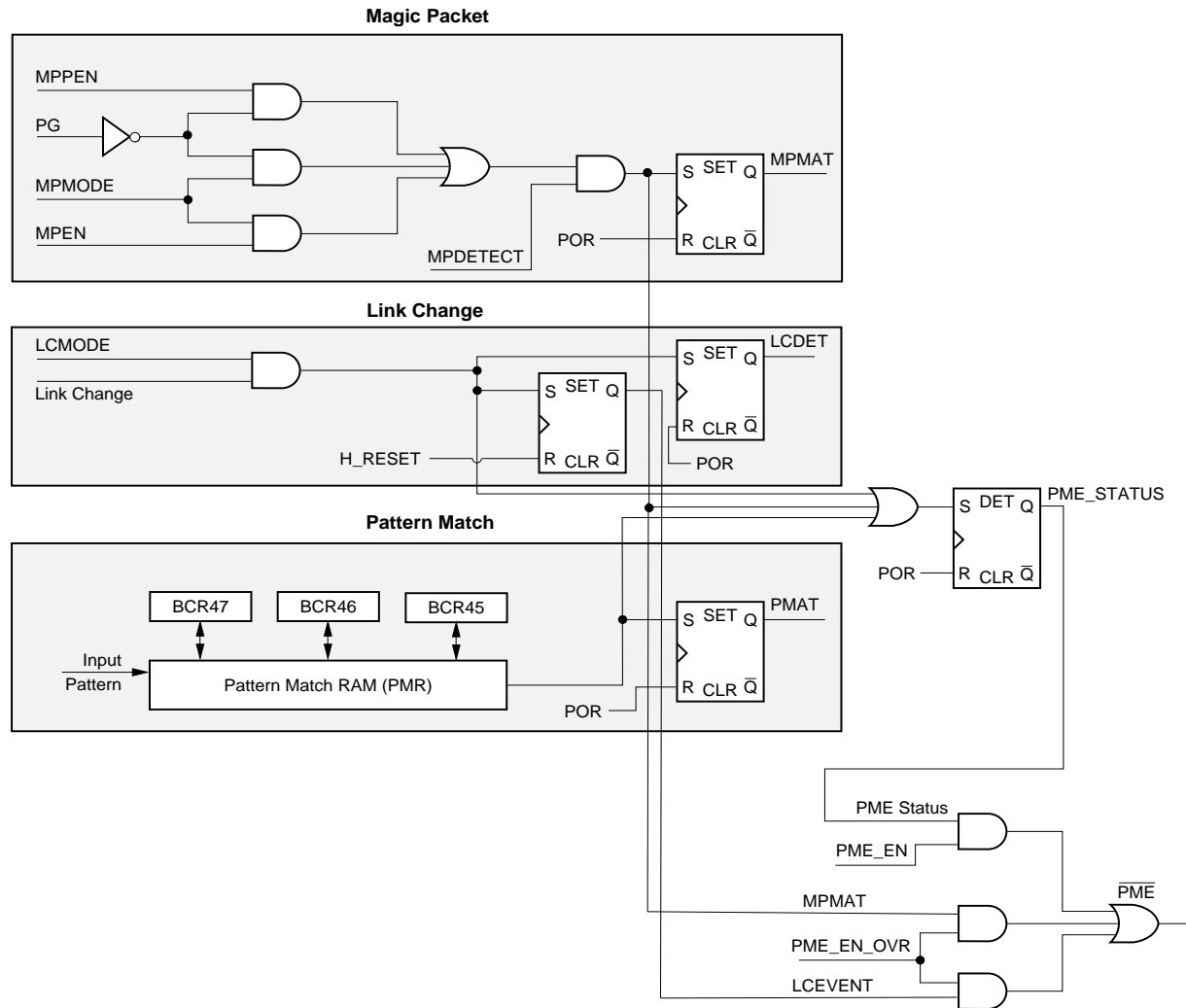

22399A-50

Figure 47. OnNow Functional Diagram

Link Change Detect

Link change detect is one of wake-up events defined by the OnNow specification. Link Change Detect mode is set when the LCMODE bit (CSR116, bit 8) is set either by software or loaded through the EEPROM.

When this bit is set, any change in the Link status will cause the LCDET bit (CSR116, bit 9) to be set. When the LCDET bit is set, the PME_STATUS bit (PMCSR register, bit 15) will be set. If either the PME_EN bit (PMCSR, bit 8) or the PME_EN_OVR bit (CSR116, bit 10) are set, then the PME will also be asserted.

OnNow Pattern Match Mode

In the OnNow Pattern Match Mode, the Am79C978A device compares the incoming packets with up to eight patterns stored in the Pattern Match RAM (PMR). The stored patterns can be

compared with part or all of incoming packets, depending on the pattern length and the way the PMR is programmed. When a pattern match has been detected, then PMAT bit (CSR116, bit 7) is set. The setting of the PMAT bit causes the PME_STATUS bit (PMCSR, bit 15) to be set, which in turn will assert the $\overline{\text{PME}}$ pin if the PME_EN bit (PMCSR, bit 8) is set.

Pattern Match RAM (PMR)

PMR is organized as an array of 64 words by 40 bits as shown in Figure 48. The PMR is programmed indirectly through BCRs 45, 46, and 47. When BCR45 is written and the PMAT_MODE bit (BCR45, bit 7) is set to 1, Pattern Match logic is enabled. No bus accesses into the PMR are possible when the PMAT_MODE bit is set, and BCR46, BCR47, and all other bits in BCR45 are ignored.

When PMAT_MODE is set, a read of BCR45 returns all bits undefined except for PMAT_MODE. In order to access the contents of the PMR, PMAT_MODE bit should be programmed to 0.

When BCR45 is written to set the PMAT_MODE bit to 0, the Pattern Match logic is disabled and accesses to the PMR are possible. Bits 6:0 of BCR45 specify the address of the PMR word to be accessed. Writing to BCR45 does not immediately affect the contents of the PMR. Following the write to BCR45, the PMR word addressed by bits 6:0 of BCR45 may be read by reading BCR45, BCR46, and BCR47 in any order. To write to the PMR word, the write to BCR45 must be followed by a write to BCR46 and a write to BCR47 in that order to complete the operation. The PMR will not actually be written until the write to BCR47 is complete.

The first two 40-bit words in this RAM serve as pointers and contain enable bits for the eight possible match patterns. The remainder of the RAM contains the match patterns and associated match pattern control bits. Byte 0 of the first word contains the pattern enable bits. Any bit position set in this byte enables the corresponding match pattern in the PMR, as an example if the bit 3 is set, then pattern 3 is enabled for matching. Bytes 1 to 4 in the first word are pointers to the beginning of the patterns 0 to 3, and bytes 1 to 4 in the second word are pointers to the beginning of patterns 4 to 7, respectively. Byte 0 of the second word has no function associated with it. Byte 0 of the words 2 to 63 is the control field of the PMR. Bit 7 of this field is the End of Packet (EOP) bit. When this bit is set, it indicates the end of a pattern in the PMR. Bits 6-4 of the control field byte are the SKIP bits. The value of the SKIP field indicates the number of the Dwords to be skipped before the pattern in this PMR word is compared with data from the incoming frame. A maximum of seven Dwords may be skipped. Bits 3-0 of the control field byte are the MASK bits. These bits correspond to the pattern match bytes 3-0 of the same PMR word (PMR bytes 4-1). If bit n of this field is 0, then byte n of the corresponding pattern word is ignored. If this field is programmed to three, then bytes 0 and 1 of the pattern match field (bytes 2 and 1 of the word) are used, and bytes 3 and 2 are ignored in the pattern matching operation.

The contents of the PMR are not affected by H_RESET, S_RESET, or STOP. The contents are undefined after a power up reset (POR).

Magic Packet Mode

In Magic Packet mode, the controller remains fully powered up (all VDD and VDDDB pins must remain at their supply levels). The device will not generate any bus master transfers. No transmit operations will be initiated on the network. The device will continue to receive frames from

the network, but all frames will be automatically flushed from the receive FIFO. Slave accesses to the controller are still possible. A Magic Packet is a frame that is addressed to the controller and contains a data sequence anywhere in its data field made up of 16 consecutive copies of the device's physical address (PADR[47:0]). The controller will search incoming frames until it finds a Magic Packet frame. It starts scanning for the sequence after processing the length field of the frame. The data sequence can begin anywhere in the data field of the frame, but must be detected before the controller reaches the frame's FCS field. Any deviation of the incoming frame's data sequence from the required physical address sequence, even by a single bit, will prevent the detection of that frame as a Magic Packet frame.

The controller supports two different modes of address detection for a Magic Packet frame. If MPPLBA (CSR5, bit 5) or EMPPLBA (CSR116, bit 6) are at their default value of 0, the controller will only detect a Magic Packet frame if the destination address of the packet matches the content of the physical address register (PADR). If MPPLBA or EMPPLBA are set to 1, the destination address of the Magic Packet frame can be unicast, multicast, or broadcast.

CAUTION: *The setting of MPPLBA or EMPPLBA only effects the address detection of the Magic Packet frame. The Magic Packet's data sequence must be made up of 16 consecutive copies of the device's physical address (PADR[47:0]), regardless of what kind of destination address it has.*

There are two general methods to place the controller into Magic Packet mode. The first is the software method. In this method, either the BIOS or other software sets the MPMODE bit (CSR5, bit 1). Then the controller must be put into suspend mode (see description of CSR5, bit 0), allowing any current network activity to finish. Finally, either PG must be deasserted (hardware control), or MPEN (CSR5, bit 2) must be set to 1 (software control).

CAUTION: *FASTSPNDE (CSR7, bit 15) has no meaning in Magic Packet mode.*

The second method is the hardware method. In this method, the MPPEN bit (CSR116, bit 4) is set at power up by the loading of the EEPROM. This bit can also be set by software. The controller will be placed in the Magic Packet Mode when either the PG input is deasserted or the MPEN bit is set. Magic Packet mode can be disabled at any time by asserting PG or clearing MPEN bit.

	BCR 47				BCR 46				BCR 45		
BCR Bit Number	15	8	7	0	15	8	7	0	15	8	
	PMR_B4		PMR_B3		PMR_B2		PMR_B1		PMR_B0		
Pattern Match RAM Address	Pattern Match RAM Bit Number										Comments
	39	32	31	24	23	16	15	8	7	0	
0	P3 pointer	P2 pointer	P1 pointer	P0 pointer	Pattern Enable bits		First Address				
1	P7 pointer	P6 pointer	P5 pointer	P4 pointer	X		Second Address				
2	Data Byte 3	Data Byte 2	Data Byte 1	Data Byte 0	Pattern Control		Start Pattern P ₁				
2+n	Data Byte 4n+3	Data Byte 4n+2	Data Byte 4n+1	Data Byte 4n+0	Pattern Control		End Pattern P ₁				
J	Data Byte 3	Data Byte 2	Data Byte 1	Data Byte 0	Pattern Control		Start Pattern P _k				
J+m	Data Byte 4m+3	Data Byte 4m+2	Data Byte 4m+1	Data Byte 4m+0	Pattern Control		End Pattern P _k				
63							Last Address				

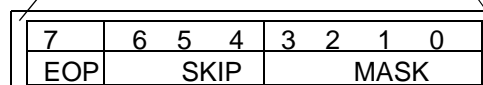

22399A-51

Figure 48. Pattern Match RAM

When the controller detects a Magic Packet frame, it sets the MPMAT bit (CSR116, bit 5), the MPINT bit (CSR5, bit 4), and the PME_STATUS bit (PMCSR, bit 15). If the PME_EN or the PME_EN_OVR bits are set, the PME will be asserted as well. If IENA (CSR0, bit 6) and MPINTE (CSR5, bit 3) are set to 1, INTA will be asserted. Any one of the four LED pins can be programmed to indicate that a Magic Packet frame has been received. MPSE (BCR4-7, bit 9) must be set to 1 to enable that function.

CAUTION: The polarity of the LED pin can be programmed to be active HIGH by setting LEDPOL (BCR4-7, bit 14) to 1.

Once a Magic Packet frame is detected, the controller will discard the frame internally, but will not resume normal transmit and receive operations

until PG is asserted or MPEN is cleared. Once both of these events has occurred, indicating that the system has detected the Magic Packet and is awake, the controller will continue polling receive and transmit descriptor rings where it left off. It is not necessary to re-initialize the device. If the part is re-initialized, then the descriptor locations will be reset and the controller will not start where it left off.

If magic packet mode is disabled by the assertion of PG, then in order to immediately re-enable Magic Packet mode, the PG pin must remain deasserted for at least 200 ns before it is reasserted. If Magic Packet mode is disabled by clearing MPEN bit, then it may be immediately re-enabled by setting MPEN back to 1.

The PCI bus interface clock (CLK) is not required to be running while the device is operating in Magic Packet mode. Either of the \overline{INTA} , the LED pins, or the \overline{PME} signal may be used to indicate the receipt of a Magic Packet frame when the CLK is stopped. If the system wishes to stop the CLK, it will do so after enabling the Magic Packet mode.

CAUTION: To prevent unwanted interrupts from other active parts of the controller, care must be taken to mask all likely interruptible events during Magic Packet mode. An example would be the interrupts from the Media Independent Interface, which could occur while the device is in Magic Packet mode.

IEEE 1149.1 (1990) Test Access Port Interface

An IEEE 1149.1-compatible boundary scan Test Access Port is provided for board-level continuity test and diagnostics. All digital input, output, and input/output pins are tested. The following paragraphs summarize the IEEE 1149.1-compatible test functions implemented in the controller.

Boundary Scan Circuit

The boundary scan test circuit requires four pins (TCK, TMS, TDI, and TDO), defined as the Test Access Port (TAP). It includes a finite state machine (FSM), an instruction register, a data register array, and a power-on reset circuit. Internal pull-up resistors are provided for the TDI, TCK, and TMS pins.

TAP Finite State Machine

The TAP engine is a 16-state finite state machine (FSM), driven by the Test Clock (TCK), and the Test Mode Select (TMS) pins. An independent power-on reset circuit is provided to ensure that the FSM is in the TEST_LOGIC_RESET state at power-up. Therefore, the \overline{TRST} is not provided. The FSM is also reset when TMS and TDI are high for five TCK periods.

Supported Instructions

In addition to the minimum IEEE 1149.1 requirements (BYPASS, EXTEST, and SAMPLE instructions), three additional instructions (IDCODE, TRIBYP, and SETBYP) are provided to further ease board-level testing. All unused instruction codes are reserved. See Table 21 for a summary of supported instructions.

Table 21. IEEE 1149.1 Supported Instruction Summary

Instruction Name	Instruction Code	Description	Mode	Selected Data Register
EXTEST	0000	External Test	Test	BSR
IDCODE	0001	ID Code Inspection	Normal	ID REG
SAMPLE	0010	Sample Boundary	Normal	BSR
TRIBYP	0011	Force Float	Normal	Bypass
SETBYP	0100	Control Boundary to I/O	Test	Bypass
BYPASS	1111	Bypass Scan	Normal	Bypass

Instruction Register and Decoding Logic

After the TAP FSM is reset, the IDCODE instruction is always invoked. The decoding logic gives signals to control the data flow in the data registers according to the current instruction.

Boundary Scan Register

Each Boundary Scan Register (BSR) cell has two stages. A flip-flop and a latch are used for the Serial Shift Stage and the Parallel Output Stage, respectively. There are four possible operation modes in the BSR cell shown in Table 22.

Table 22. BSR Mode Of Operation

1	Capture
2	Shift
3	Update
4	System Function

Other Data Registers

Other data registers are the following:

1. Bypass register (1 bit)
2. Device ID register (32 bits) (See Table 23.).

Table 23. Device ID Register

Bits 31-28	Version
Bits 27-12	Part Number (0010 0110 0010 0110)
Bits 11-1	Manufacturer ID. The 11 bit manufacturer ID cod for AMD is 00000000001 in accordance with JEDEC publication 106-A.
Bit 0	Always a logic 1

CAUTION: The content of the Device ID register is the same as the content of CSR88.

NAND Tree Testing

The controller provides a NAND tree test mode to allow checking connectivity to the device on a printed circuit board. The NAND tree is built on all PCI bus pins.

NAND tree testing is enabled by asserting \overline{RST} . PG input should be driven HIGH during NAND tree testing. All PCI bus signals will become inputs on the assertion of \overline{RST} . The result of the NAND tree test can be observed on the \overline{INTA} pin. See Figure 49.

Pin 141 (\overline{RST}) is the first input to the NAND tree. Pin 142 (CLK) is the second input to the NAND tree, followed by pin 143 (\overline{GNT}). All other PCI bus signals follow, counter-clockwise, with pin 61 (AD0) being the last. Table 24 and Table 25 shows the complete list of pins connected to the NAND tree.

\overline{RST} must be asserted low to start a NAND tree test sequence. Initially, all NAND tree inputs except \overline{RST} should be driven high. This will result in a high output at the \overline{INTA} pin. If the NAND tree inputs are driven from high to low in the same order as they are connected to build the NAND tree, \overline{INTA} will toggle every time an additional input is driven low. \overline{INTA} will change to low, when CLK is driven low and all other NAND tree inputs stay high. \overline{INTA} will toggle back to high, when \overline{GNT} is additionally driven low. The square wave will continue until all NAND tree inputs are driven low. \overline{INTA} will be high, when all NAND tree inputs are driven low. See Figure 50.

Some of the pins connected to the NAND tree are outputs in normal mode of operation. They must not be driven from an external source until the controller is configured for NAND tree testing.

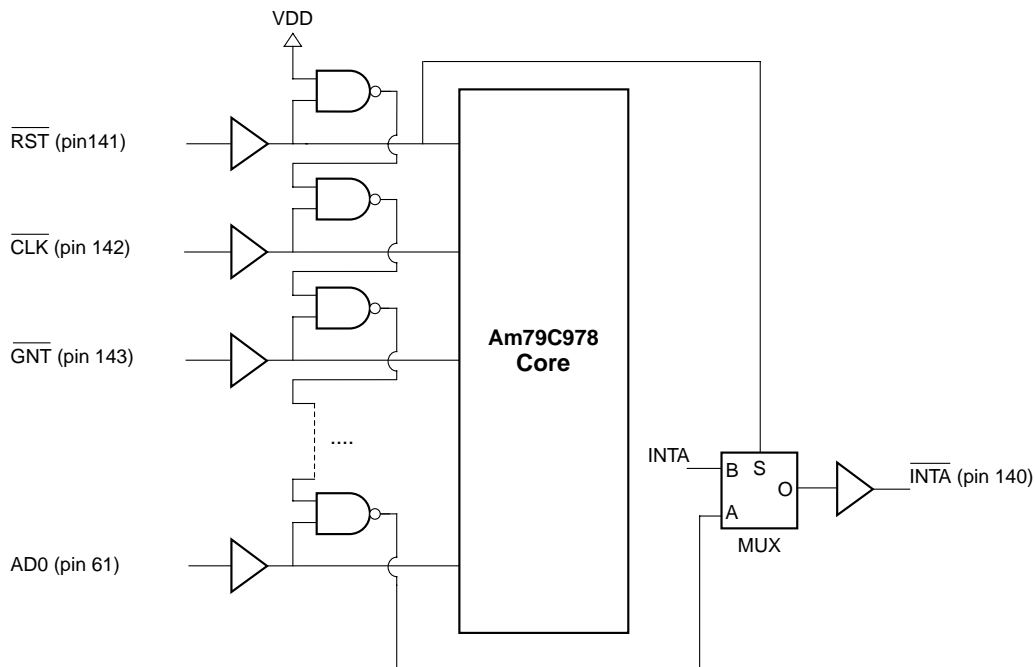

22399A-52

Figure 49. NAND Tree Circuitry (160 PQFP)

Table 24. NAND Tree Pin Sequence (160 PQFP)

NAND Tree Input No.	Pin No.	Name	NAND Tree Input No.	Pin No.	Name	NAND Tree Input No.	Pin No.	Name
1	141	$\overline{\text{RST}}$	18	9	AD20	35	36	AD13
2	142	PCI_CLK	19	11	AD19	36	38	AD12
3	143	$\overline{\text{GNT}}$	20	12	AD18	37	43	AD11
4	144	$\overline{\text{REQ}}$	21	14	AD17	38	45	AD10
5	146	AD31	22	16	AD16	39	46	AD9
6	149	AD30	23	17	$\text{C}/\overline{\text{BE}}2$	40	47	AD8
7	150	AD29	24	19	$\overline{\text{FRAME}}$	41	48	$\text{C}/\overline{\text{BE}}0$
8	151	AD28	25	20	$\overline{\text{IRDY}}$	42	50	AD7
9	152	AD27	26	22	$\overline{\text{TRDY}}$	43	52	AD6
10	154	AD26	27	24	$\overline{\text{DEVSEL}}$	44	53	AD5
11	156	AD25	28	25	$\overline{\text{STOP}}$	45	55	AD4
12	157	AD24	29	27	$\overline{\text{PERR}}$	46	56	AD3
13	158	$\text{C}/\overline{\text{BE}}3$	30	28	$\overline{\text{SERR}}$	47	58	AD2
14	3	IDSEL	31	30	PAR	48	60	AD1
15	4	AD23	32	32	$\text{C}/\overline{\text{BE}}1$	49	61	AD0
16	6	AD22	33	33	AD15	50		
17	8	AD21	34	35	AD14	51		

Table 25. NAND Tree Pin Sequence (144 TQFP)

NAND Tree Input No.	Pin No.	Name	NAND Tree Input No.	Pin No.	Name	NAND Tree Input No.	Pin No.	Name
1	127	$\overline{\text{RST}}$	18	7	AD20	35	34	AD13
2	128	PCI_CLK	19	9	AD19	36	36	AD12
3	129	$\overline{\text{GNT}}$	20	10	AD18	37	37	AD11
4	130	$\overline{\text{REQ}}$	21	12	AD17	38	39	AD10
5	132	AD31	22	14	AD16	39	40	AD9
6	135	AD30	23	15	$\text{C}/\overline{\text{BE}}2$	40	41	AD8
7	136	AD29	24	17	$\overline{\text{FRAME}}$	41	42	$\text{C}/\overline{\text{BE}}0$
8	137	AD28	25	18	$\overline{\text{IRDY}}$	42	44	AD7
9	138	AD27	26	20	$\overline{\text{TRDY}}$	43	46	AD6
10	140	AD26	27	22	$\overline{\text{DEVSEL}}$	44	47	AD5
11	142	AD25	28	23	$\overline{\text{STOP}}$	45	49	AD4
12	143	AD24	29	25	$\overline{\text{PERR}}$	46	50	AD3
13	144	$\text{C}/\overline{\text{BE}}3$	30	26	$\overline{\text{SERR}}$	47	52	AD2
14	1	IDSEL	31	28	PAR	48	54	AD1
15	2	AD23	32	30	$\text{C}/\overline{\text{BE}}1$	49	55	AD0
16	4	AD22	33	31	AD15			
17	6	AD21	34	33	AD14			

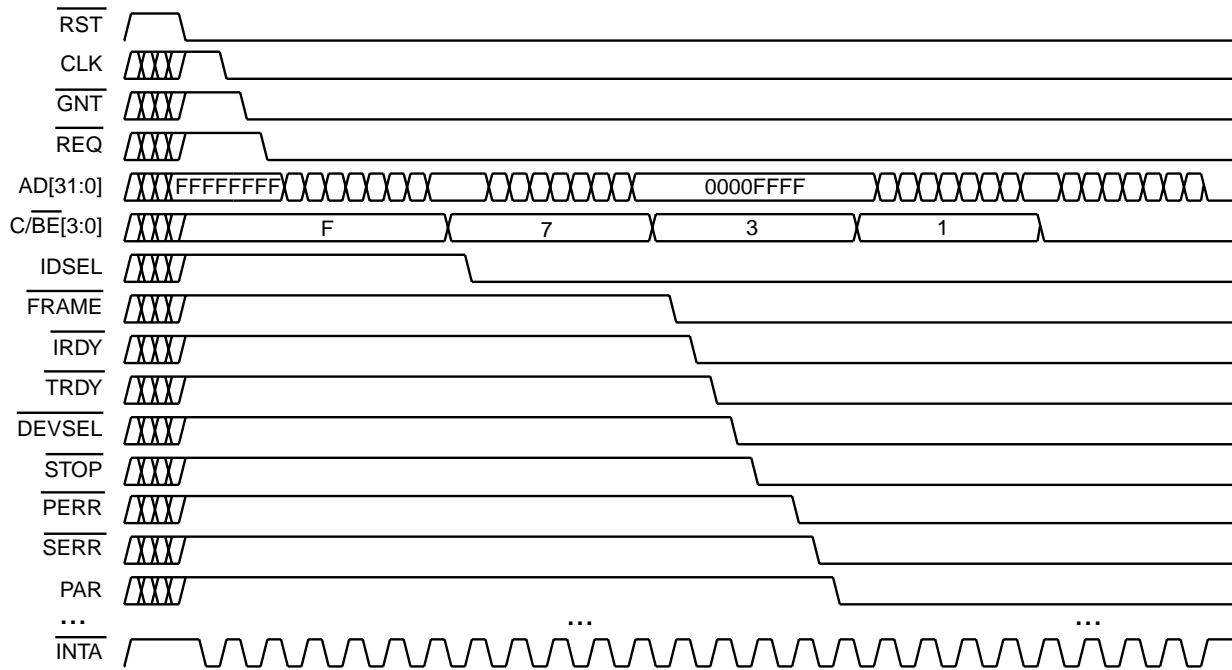

22399A-53

Figure 50. NAND Tree Waveform

Reset

There are four different types of RESET operations that may be performed on the Am79C978A device, H_RESET, S_RESET, STOP, and POR. The following is a description of each type of RESET operation.

H_RESET

Hardware Reset (H_RESET) is an Am79C978A reset operation that has been created by the proper assertion of the $\overline{\text{RST}}$ pin of the Am79C978A device while the PG pin is HIGH. When the minimum pulse width timing as specified in the $\overline{\text{RST}}$ pin description has been satisfied, an internal reset operation will be performed.

H_RESET will program most of the CSR and BCR registers to their default value. Note that there are several CSR and BCR registers that are undefined after H_RESET. See the sections on the individual registers for details.

H_RESET will clear most of the registers in the PCI configuration space. H_RESET will cause the microcode program to jump to its reset state. Following the end of the H_RESET operation, the controller will attempt to read the EEPROM device through the EEPROM interface.

H_RESET will clear DWIO (BCR18, bit 7) and the controller will be in 16-bit I/O mode after the reset operation. A DWord write operation to the RDP (I/O offset 10h) must be performed to set the device into 32-bit I/O mode.

S_RESET

Software Reset (S_RESET) is an Am79C978A reset operation that has been created by a read access to the Reset register, which is located at offset 14h in Word I/O mode or offset 18h in DWord I/O mode from the Am79C978A I/O or memory mapped I/O base address.

S_RESET will reset all of or some portions of CSR0, 3, 4, 15, 80, 100, and 124 to default values. For the identity of individual CSRs and bit locations that are affected by S_RESET, see the individual CSR register descriptions. S_RESET will not affect any PCI configuration space location. S_RESET will not affect any of the BCR register values. S_RESET will cause the microcode program to jump to its reset state. Following the end of the S_RESET operation, the controller will not attempt to read the EEPROM device. After S_RESET, the host must perform a full re-initialization of the controller before starting network activity. S_RESET will cause $\overline{\text{REQ}}$ to deassert immediately. STOP (CSR0, bit 2) or SPND (CSR5, bit 0) can be used to terminate any pending bus mastership request in an orderly sequence.

S_RESET terminates all network activity abruptly. The host can use the suspend mode (SPND, CSR5, bit 0) to terminate all network activity in an orderly sequence before issuing an S_RESET.

STOP

A STOP reset is generated by the assertion of the STOP bit in CSR0. Writing a 1 to the STOP bit of CSR0, when the stop bit currently has a value of 0, will initiate a STOP reset. If the STOP bit is already a 1, then writing a 1 to the STOP bit will not generate a STOP reset.

STOP will reset all or some portions of CSR0, 3, and 4 to default values. For the identity of individual CSRs and bit locations that are affected by STOP, see the individual CSR register descriptions. STOP will not affect any of the BCR and PCI configuration space locations. STOP will cause the microcode program to jump to its reset state. Following the end of the STOP operation, the controller will not attempt to read the EEPROM device.

CAUTION: STOP will not cause a deassertion of the *REQ* signal, if it happens to be active at the time of the write to CSR0. The controller will wait until it gains bus ownership, and it will first finish all scheduled bus master accesses before the STOP reset is executed.

STOP terminates all network activity abruptly. The host can use the suspend mode (SPND, CSR5, bit 0) to termi-

nate all network activity in an orderly sequence before setting the STOP bit.

Power on Reset

Power on Reset (POR) is generated when the controller is powered up. POR generates a hardware reset (H_RESET). In addition, it clears some bits that H_RESET does not affect.

Software Access

PCI Configuration Registers

The controller implements the 256-byte configuration space as defined by the PCI draft specification revision 2.2. The 64-byte header includes all registers required to identify the controller and its function. Additionally, PCI Power Management Interface registers are implemented at location 40h - 47h. The layout of the PCI configuration space is shown in Table 26.

The PCI configuration registers are accessible only by configuration cycles. All multi-byte numeric fields follow little endian byte ordering. All write accesses to Reserved locations have no effect; reads from these locations will return a data value of 0.

Table 26. PCI Configuration Space Layout

31	24	23	16	15	8	7	0	Offset
Device ID				Vendor ID				00h
Status				Command				04h
Base-Class		Sub-Class		Programming IF		Revision ID		08h
Reserved		Header Type		Latency Timer		Reserved		0Ch
I/O Base Address								10h
Memory Mapped I/O Base Address								14h
Reserved								18h
Reserved								1Ch
Reserved								20h
Reserved								24h
Reserved								28h
Subsystem ID				Subsystem Vendor ID				2Ch
Expansion ROM Base Address								30h
Reserved						CAP-PTR		34h
Reserved								38h
MAX_LAT		MIN_GNT		Interrupt Pin		Interrupt Line		3Ch
PMC				NXT_ITM_PTR		CAP_ID		40h
DATA_REG		PMCSR_BSE		PMCSR				44H
Reserved								.
Reserved								FCh

I/O Resources

The Am79C978A controller requires 32 bytes of address space for access to all the various internal registers as well as to some setup information stored in an external serial EEPROM. A software reset port is available, too.

The Am79C978A controller supports mapping the address space to both I/O and memory space. The value in the PCI I/O Base Address register determines the start address of the I/O address space. The register is typically programmed by the PCI configuration utility after system power-up. The PCI configuration utility must also set the IOEN bit in the PCI Command register to enable I/O accesses to the Am79C978A controller. For memory mapped I/O access, the PCI Memory Mapped I/O Base Address register controls the start address of the memory space. The MEMEN bit in the PCI Command register must also be set to enable the mode. Both base address registers can be active at the same time.

The Am79C978A controller supports two modes for accessing the I/O resources. For backwards compatibility with AMD's 16-bit Ethernet controllers, Word I/O is the default mode after power up. The device can be configured to DWord I/O mode by software.

I/O Registers

The Am79C978A controller registers are divided into two groups. The Control and Status Registers (CSR) are used to configure the Ethernet MAC engine and to obtain status information. The Bus Control Registers (BCR) are used to configure the bus interface unit and the LEDs. Both sets of registers are accessed using indirect addressing.

The CSR and BCR share a common Register Address Port (RAP). There are, however, separate data ports. The Register Data Port (RDP) is used to access a CSR. The BCR Data Port (BDP) is used to access a BCR.

In order to access a particular CSR location, the RAP should first be written with the appropriate CSR address. The RDP will then point to the selected CSR. A read of the RDP will yield the selected CSR data. A write to the RDP will write to the selected CSR. In order to access a particular BCR location, the RAP should first be written with the appropriate BCR address. The BDP will then point to the selected BCR. A read of the BDP will yield the selected BCR data. A write to the BDP will write to the selected BCR.

Once the RAP has been written with a value, the RAP value remains unchanged until another RAP write occurs, or until an H_RESET or S_RESET occurs. RAP is cleared to all 0s when an H_RESET or S_RESET occurs. RAP is unaffected by setting the STOP bit.

Address PROM Space

The Am79C978A controller allows for connection of a serial EEPROM. The first 16 bytes of the EEPROM will be automatically loaded into the Address PROM (APROM) space after H_RESET. Additionally, the first six bytes of the EEPROM will be loaded into CSR12 to CSR14. The Address PROM space is a convenient place to store the value of the 48-bit IEEE station address. It can be overwritten by the host computer, and its content has no effect on the operation of the Am79C978A controller. The software must copy the station address from the Address PROM space to the initialization block in order for the receiver to accept unicast frames directed to this station.

The six bytes of the IEEE station address occupy the first six locations of the Address PROM space. The next six bytes are reserved. Bytes 12 and 13 should match the value of the checksum of bytes 1 through 11 and 14 and 15. Bytes 14 and 15 should each be ASCII "W" (57h). The above requirements must be met in order to be compatible with AMD driver software. APROMWE bit (BCR2, bit 8) must be set to 1 to enable write access to the Address PROM space.

Reset Register

A read of the Reset register creates an internal software reset (S_RESET) pulse in the Am79C978A controller. The internal S_RESET pulse that is generated by this access is different from both the assertion of the hardware $\overline{\text{RST}}$ pin (H_RESET) and from the assertion of the software STOP bit. Specifically, S_RESET is the equivalent of the assertion of the $\overline{\text{RST}}$ pin (H_RESET) except that S_RESET has no effect on the BCR or PCI Configuration space locations.

The NE2100 LANCE-based family of Ethernet cards requires that a write access to the Reset register follows each read access to the Reset register. The Am79C978A controller does not have a similar requirement. The write access is not required and does not have any effect.

Note: The Am79C978A controller cannot service any slave accesses for a very short time after a read access of the Reset register, because the internal S_RESET operation takes about 1 ms to finish. The Am79C978A controller will terminate all slave accesses with the assertion of DEVSEL and STOP while TRDY is not asserted, signaling to the initiator to disconnect and retry the access at a later time.

Word I/O Mode

After H_RESET, the Am79C978A controller is programmed to operate in Word I/O mode. DWIO (BCR18, bit 7) will be cleared to 0. Table 27 shows how the 32 bytes of address space are used in Word I/O mode.

All I/O resources must be accessed in word quantities and on word addresses. The Address PROM locations can also be read in byte quantities. The only allowed DWord operation is a write access to the RDP, which

switches the device to DWord I/O mode. A read access other than listed in the table below will yield undefined data; a write operation may cause unexpected reprogramming of the Am79C978A control registers. Table 28 shows legal I/O accesses in Word I/O mode.

Table 27. I/O Map in Word I/O Mode (DWIO = 0)

Offset	No. of Bytes	Register
00h - 0Fh	16	APROM
10h	2	RDP
12h	2	RAP (shared by RDP and BDP)
14h	2	Reset Register
16h	2	BDP
18h - 1Fh	8	Reserved

Double Word I/O Mode

The Am79C978A controller can be configured to operate in DWord (32-bit) I/O mode. The software can invoke the DWIO mode by performing a DWord write access

to the I/O location at offset 10h (RDP). The data of the write access must be such that it does not affect the intended operation of the Am79C978A controller. Setting the device into 32-bit I/O mode is usually the first operation after H_RESET or S_RESET. The RAP register will point to CSR0 at that time. Writing a value of 0 to CSR0 is a safe operation. DWIO (BCR18, bit 7) will be set to 1 as an indication that the Am79C978A controller operates in 32-bit I/O mode.

Note: *Even though the I/O resource mapping changes when the I/O mode setting changes, the RDP location offset is the same for both modes. Once the DWIO bit has been set to 1, only H_RESET can clear it to 0. The DWIO mode setting is unaffected by S_RESET or setting of the STOP bit. Table 29 shows how the 32 bytes of address space are used in DWord I/O mode.*

All I/O resources must be accessed in DWord quantities and on DWord addresses. A read access other than listed in Table 30 will yield undefined data, a write operation may cause unexpected reprogramming of the Am79C978A control registers.

Table 28. Legal I/O Accesses in Word I/O Mode (DWIO = 0)

AD[4:0]	BE[3:0]	Type	Comment
0XX00	1110	RD	Byte read of APROM location 0h, 4h, 8h, or Ch
0XX01	1101	RD	Byte read of APROM location 1h, 5h, 9h, or Dh
0XX10	1011	RD	Byte read of APROM location 2h, 6h, Ah, or Eh
0XX11	0111	RD	Byte read of APROM location 3h, 7h, Bh, or Fh
0XX00	1100	RD	Word read of APROM locations 1h (MSB) and 0h (LSB), 5h and 4h, 8h and 9h, or Ch and Dh
0XX10	0011	RD	Word read of APROM locations 3h (MSB) and 2h (LSB), 7h and 6h, Bh and Ah, or Fh and Eh
10000	1100	RD	Word read of RDP
10010	0011	RD	Word read of RAP
10100	1100	RD	Word read of Reset Register
10110	0011	RD	Word read of BDP
0XX00	1100	WR	Word write to APROM locations 1h (MSB) and 0h (LSB), 5h and 4h, 8h and 9h, or Ch and Dh
0XX10	0011	WR	Word write to APROM locations 3h (MSB) and 2h (LSB), 7h and 6h, Bh and Ah, or Fh and Eh
10000	1100	WR	Word write to RDP
10010	0011	WR	Word write to RAP
10100	1100	WR	Word write to Reset Register
10110	0011	WR	Word write to BDP
10000	0000	WR	DWord write to RDP, switches device to DWord I/O mode

Table 29. I/O Map in DWord I/O Mode (DWIO = 1)

Offset	No. of Bytes	Register
00h - 0Fh	16	APROM
10h	4	RDP
14h	4	RAP (shared by RDP and BDP)
18h	4	Reset Register
1Ch	4	BDP

Table 30. Legal I/O Accesses in Double Word I/O Mode (DWIO =1)

AD[4:0]	$\overline{\text{BE}}[3:0]$	Type	Comment
0XX00	0000	RD	DWord read of APROM locations 3h (MSB) to 0h (LSB), 7h to 4h, Bh to 8h, or Fh to Ch
10000	0000	RD	DWord read of RDP
10100	0000	RD	DWord read of RAP
11000	0000	RD	DWord read of Reset Register
0XX00	0000	WR	DWord write to APROM locations 3h (MSB) to 0h (LSB), 7h to 4h, Bh to 8h, or Fh to Ch
10000	0000	WR	DWord write to RDP
10100	0000	WR	DWord write to RAP
11000	0000	WR	DWord write to Reset Register

USER ACCESSIBLE REGISTERS

The Am79C978A controller has four types of user registers: the PCI configuration registers, the Control and Status registers (CSRs), the Bus Control registers (BCRs), 10BASE-T PHY Management registers (TBRs), and 1 Mbps HomePNA PHY Management registers (HPRs).

The Am79C978A controller implements all PCnet-ISA (Am79C960) registers, all C-LANCE (Am79C90) registers, plus a number of additional registers. The Am79C978A CSRs are compatible upon power up with both the PCnet-ISA CSRs and all of the C-LANCE CSRs.

The PCI configuration registers can be accessed in any data width. All other registers must be accessed according to the I/O mode that is currently selected. When WIO mode is selected, all other register locations are defined to be 16 bits in width. When DWIO mode is selected, all these register locations are defined to be 32 bits in width, with the upper 16 bits of most register locations marked as reserved locations with undefined values. When performing register write operations in DWIO mode, the upper 16 bits should always be written as zeros. When performing register read operations in DWIO mode, the upper 16 bits of I/O resources should always be regarded as having undefined values, except for CSR88.

The Am79C978A registers can be divided into four groups: PCI Configuration, Setup, Running, and Test. Registers not included in any of these categories can be assumed to be intended for diagnostic purposes.

■ PCI Configuration Registers

These registers are intended to be initialized by the system initialization procedure (e.g., BIOS device initialization routine) to program the operation of the controller PCI bus interface.

The following is a list of the registers that would typically need to be programmed once during the initialization of the Am79C978A controller within a system:

- PCI I/O Base Address or Memory Mapped I/O Base Address register
- PCI Expansion ROM Base Address register
- PCI Interrupt Line register
- PCI Latency Timer register
- PCI Status register
- PCI Command register
- OnNow register

■ Setup Registers

These registers are intended to be initialized by the device driver to program the operation of various controller features.

The following is a list of the registers that would typically need to be programmed once during the setup of the controller within a system. The control bits in each of these registers typically do not need to be modified once they have been written. However, there are no restrictions as to how many times these registers may actually be accessed. Note that if the default power up values of any of these registers is acceptable to the application, then such registers need never be accessed at all.

Note: Registers marked with “^” may be programmable through the EEPROM read operation and, therefore, do not necessarily need to be written to by the system initialization procedure or by the driver software. Registers marked with “*” will be initialized by the initialization block read operation.

CSR1	Initialization Block Address[15:0]
CSR2*	Initialization Block Address[31:16]
CSR3	Interrupt Masks and Deferral Control
CSR4	Test and Features Control
CSR5	Extended Control and Interrupt
CSR7	Extended Control and Interrupt2
CSR8*	Logical Address Filter[15:0]
CSR9*	Logical Address Filter[31:16]
CSR10*	Logical Address Filter[47:32]
CSR11*	Logical Address Filter[63:48]
CSR12*^	Physical Address[15:0]
CSR13*^	Physical Address[31:16]
CSR14*^	Physical Address[47:32]
CSR15*	Mode
CSR24*	Base Address of Receive Ring Lower
CSR25*	Base Address of Receive Ring Upper
CSR30*	Base Address of Transmit Ring Lower
CSR31*	Base Address of Transmit Ring Upper
CSR47*	Transmit Polling Interval
CSR49*	Receive Polling Interval
CSR76*	Receive Ring Length
CSR78*	Transmit Ring Length
CSR80	DMA Transfer Counter and FIFO Threshold Control
CSR82	Bus Activity Timer
CSR100	Memory Error Timeout
CSR116^	OnNow Miscellaneous
CSR122	Receiver Packet Alignment Control

CSR125 [^]	MAC Enhanced Configuration Control
BCR2 [^]	Miscellaneous Configuration
BCR4 [^]	LED0 Status
BCR5 [^]	LED1 Status
BCR6 [^]	LED2 Status
BCR7 [^]	LED3 Status
BCR9 [^]	Full-Duplex Control
BCR18 [^]	Bus and Burst Control
BCR19	EEPROM Control and Status
BCR20	Software Style
BCR22 [^]	PCI Latency
BCR23 [^]	PCI Subsystem Vendor ID
BCR24 [^]	PCI Subsystem ID
BCR25 [^]	SRAM Size
BCR26 [^]	SRAM Boundary
BCR27 [^]	SRAM Interface Control
BCR32 [^]	Internal PHY Control and Status
BCR33 [^]	Internal PHY Address
BCR35 [^]	PCI Vendor ID
BCR36	PCI Power Management Capabilities (PMC) Alias Register
BCR37	PCI DATA Register 0 (DATA0) Alias Register
BCR38	PCI DATA Register 1 (DATA1) Alias Register
BCR39	PCI DATA Register 2 (DATA2) Alias Register
BCR40	PCI DATA Register 3 (DATA3) Alias Register
BCR41	PCI DATA Register 4 (DATA4) Alias Register
BCR42	PCI DATA Register 5 (DATA5) Alias Register
BCR43	PCI DATA Register 6 (DATA6) Alias Register
BCR44	PCI DATA Register 7 (DATA7) Alias Register
BCR45	OnNow Pattern Matching Register 1
BCR46	OnNow Pattern Matching Register 2
BCR47	OnNow Pattern Matching Register 3
BCR48	LED4 Status
BCR49	PHY Select

■ Running Registers

These registers are intended to be used by the device driver software after the Am79C978A controller is running to access status information and to pass control information.

The following is a list of the registers that would typically need to be periodically read and perhaps written during the normal running operation of the Am79C978A controller within a system. Each of these registers contains control bits, or status bits, or both.

RAP	Register Address Port
CSR0	Controller Status
CSR3	Interrupt Masks and Deferral Control
CSR4	Test and Features Control
CSR5	Extended Control and Interrupt
CSR7	Extended Control and Interrupt 2
CSR112	Missed Frame Count
CSR114	Receive Collision Count
BCR32	Internal PHY Control and Status
BCR33	Internal PHY Address
BCR34	Internal PHY Management Data

■ Test Registers

These registers are intended to be used only for testing and diagnostic purposes. Those registers not included in any of the above lists can be assumed to be intended for diagnostic purposes.

PCI Configuration Registers

PCI Vendor ID Register

Offset 00h

The PCI Vendor ID register is a 16-bit register that identifies the manufacturer of the Am79C978A controller. AMD's Vendor ID is 1022h. Note that this Vendor ID is not the same as the Manufacturer ID in CSR88 and CSR89. The Vendor ID is assigned by the PCI Special Interest Group.

The PCI Vendor ID register is located at offset 00h in the PCI Configuration Space. It is read only.

This register is the same as BCR35 and can be written by the EEPROM.

PCI Device ID Register

Offset 02h

The PCI Device ID register is a 16-bit register that helps identify the Am79C978A controller within AMD's product line. The Am79C978A Device ID is 2001h. Note that this Device ID is not the same as the part number in CSR88 and CSR89. The Device ID is assigned by AMD.

The PCI Device ID register is located at offset 02h in the PCI Configuration Space. It is read only.

PCI Command Register

Offset 04h

The PCI Command register is a 16-bit register used to control the gross functionality of the Am79C978A controller. It controls the Am79C978A controller’s ability to generate and respond to PCI bus cycles. To logically disconnect the Am79C978A device from all PCI bus cycles except configuration cycles, a value of 0 should be written to this register.

The PCI Command register is located at offset 04h in the PCI Configuration Space. It is read and written by the host.

Bit	Name	Description
15-10	RES	Reserved locations. Read as zeros; write operations have no effect.
9	FBTBEN	Fast Back-to-Back Enable. Read as zero; write operations have no effect. The Am79C978A controller will not generate Fast Back-to-Back cycles.
8	SERREN	SERR Enable. Controls the assertion of the $\overline{\text{SERR}}$ pin. $\overline{\text{SERR}}$ is disabled when SERREN is cleared. $\overline{\text{SERR}}$ will be asserted on detection of an address parity error and if both SERREN and PERREN (bit 6 of this register) are set. SERREN is cleared by H_RESET and is not effected by S_RESET or by setting the STOP bit.
7	RES	Reserved location. Read as zeros; write operations have no effect.
6	PERREN	Parity Error Response Enable. Enables the parity error response functions. When PERREN is 0 and the Am79C978A controller detects a parity error, it only sets the Detected Parity Error bit in the PCI Status register. When PERREN is 1, the Am79C978A controller asserts $\overline{\text{PERR}}$ on the detection of a data parity error. It also sets the DATAPERR bit (PCI Status register, bit 8), when the

data parity error occurred during a master cycle. PERREN also enables reporting address parity errors through the $\overline{\text{SERR}}$ pin and the $\overline{\text{SERR}}$ bit in the PCI Status register.

PERREN is cleared by H_RESET and is not affected by S_RESET or by setting the STOP bit.

5	VGASNOOP	VGA Palette Snoop. Read as zero; write operations have no effect.
4	MWIEN	Memory Write and Invalidate Cycle Enable. Read as zero; write operations have no effect. The Am79C978A controller only generates Memory Write cycles.
3	SCYCEN	Special Cycle Enable. Read as zero; write operations have no effect. The Am79C978A controller ignores all Special Cycle operations.
2	BMEN	Bus Master Enable. Setting BMEN enables the Am79C978A controller to become a bus master on the PCI bus. The host must set BMEN before setting the INIT or STRT bit in CSR0 of the Am79C978A controller. BMEN is cleared by H_RESET and is not effected by S_RESET or by setting the STOP bit.
1	MEMEN	Memory Space Access Enable. The Am79C978A controller will ignore all memory accesses when MEMEN is cleared. The host must set MEMEN before the first memory access to the device. For memory mapped I/O, the host must program the PCI Memory Mapped I/O Base Address register with a valid memory address before setting MEMEN. For accesses to the Expansion ROM, the host must program the PCI Expansion ROM Base Address register at offset 30h with a valid memory address

before setting MEMEN. The Am79C978A controller will only respond to accesses to the Expansion ROM when both ROMEN (PCI Expansion ROM Base Address register, bit 0) and MEMEN are set to 1. Since MEMEN also enables the memory mapped access to the Am79C978A I/O resources, the PCI Memory Mapped I/O Base Address register must be programmed with an address so that the device does not claim cycles not intended for it.

MEMEN is cleared by H_RESET and is not effected by S_RESET or by setting the STOP bit.

0 IOEN I/O Space Access Enable. The Am79C978A controller will ignore all I/O accesses when IOEN is cleared. The host must set IOEN before the first I/O access to the device. The PCI I/O Base Address register must be programmed with a valid I/O address before setting IOEN.

IOEN is cleared by H_RESET and is not effected by S_RESET or by setting the STOP bit.

data is transferred ($\overline{\text{TRDY}}$ and $\overline{\text{IRDY}}$ are asserted).

In master mode, during the data phase of all memory read commands.

In master mode, during the data phase of the memory write command, the Am79C978A controller sets the PERR bit if the target reports a data parity error by asserting the $\overline{\text{PERR}}$ signal.

PERR is not effected by the state of the Parity Error Response enable bit (PCI Command register, bit 6).

PERR is set by the Am79C978A controller and cleared by writing a 1. Writing a 0 has no effect. PERR is cleared by H_RESET and is not affected by S_RESET or by setting the STOP bit.

14 SERR Signaled SERR. SERR is set when the Am79C978A controller detects an address parity error and both SERREN and PERREN (PCI Command register, bits 8 and 6) are set.

SERR is set by the Am79C978A controller and cleared by writing a 1. Writing a 0 has no effect. SERR is cleared by H_RESET and is not affected by S_RESET or by setting the STOP bit.

PCI Status Register

Offset 06h

The PCI Status register is a 16-bit register that contains status information for the PCI bus related events. It is located at offset 06h in the PCI Configuration Space.

Bit	Name	Description
15	PERR	Parity Error. PERR is set when the Am79C978A controller detects a parity error. The Am79C978A controller samples the AD[31:0], C/ $\overline{\text{BE}}$ [3:0], and the PAR lines for a parity error at the following times: <ul style="list-style-type: none"> In slave mode, during the address phase of any PCI bus command. In slave mode, for all I/O, memory, and configuration write commands that select the Am79C978A controller when

13 RMABORT Received Master Abort. RMABORT is set when the Am79C978A controller terminates a master cycle with a master abort sequence.

RMABORT is set by the Am79C978A controller and cleared by writing a 1. Writing a 0 has no effect. RMABORT is cleared by H_RESET and is not affected by S_RESET or by setting the STOP bit.

12 RTABORT Received Target Abort. RTABORT is set when a target terminates an Am79C978A master cycle with a target abort sequence.

		RTABORT is set by the Am79C978A controller and cleared by writing a 1. Writing a 0 has no effect. RTABORT is cleared by H_RESET and is not affected by S_RESET or by setting the STOP bit.		controller is capable of accepting fast back-to-back transactions with the first transaction addressing a different target.	
11	STABORT	Send Target Abort. Read as zero; write operations have no effect. The Am79C978A controller will never terminate a slave access with a target abort sequence.			
		STABORT is read only.			
10-9	DEVSEL	Device Select Timing. DEVSEL is set to 01b (medium), which means that the Am79C978A controller will assert DEVSEL two clock periods after FRAME is asserted.		Read as one; write operations have no effect. The Am79C978A controller supports the Linked Additional Capabilities List.	
		DEVSEL is read only.			
8	DATAPERR	Data Parity Error Detected. DATAPERR is set when the Am79C978A controller is the current bus master and it detects a data parity error and the Parity Error Response enable bit (PCI Command register, bit 6) is set.			
		During the data phase of all memory read commands, the Am79C978A controller checks for parity error by sampling AD[31:0], C/BE[3:0], and the PAR lines. During the data phase of all memory write commands, the Am79C978A controller checks the PERR input to detect whether the target has reported a parity error.			
		DATAPERR is set by the Am79C978A controller and cleared by writing a 1. Writing a 0 has no effect. DATAPERR is cleared by H_RESET and is not affected by S_RESET or by setting the STOP bit.			
7	FBTBC	Fast Back-To-Back Capable. Read as one; write operations have no effect. The Am79C978A			
			6-5	RES	Reserved locations. Read as zero; write operations have no effect.
			4	NEW_CAP	New Capabilities. This bit indicates whether this function implements a list of extended capabilities such as PCI power management. When set, this bit indicates the presence of New Capabilities. A value of 0 means that this function does not implement New Capabilities.
			3-0	RES	Reserved locations. Read as zero; write operations have no effect.

PCI Revision ID Register

Offset 08h

The PCI Revision ID register is an 8-bit register that specifies the Am79C978A controller revision number. The value of this register is 5Xh with the lower four bits being silicon-revision dependent.

The PCI Revision ID register is located at offset 08h in the PCI Configuration Space. It is read only.

PCI Programming Interface Register

Offset 09h

The PCI Programming Interface register is an 8-bit register that identifies the programming interface of Am79C978A controller. PCI does not define any specific register-level programming interfaces for network devices. The value of this register is 00h.

The PCI Programming Interface register is located at offset 09h in the PCI Configuration Space. It is read only.

PCI Sub-Class Register

Offset 0Ah

The PCI Sub-Class register is an 8-bit register that identifies specifically the function of the Am79C978A controller. The value of this register is 00h which identifies the Am79C978A device as an Ethernet controller.

The PCI Sub-Class register is located at offset 0Ah in the PCI Configuration Space. It is read only.

PCI Base-Class Register

Offset 0Bh

The PCI Base-Class register is an 8-bit register that broadly classifies the function of the Am79C978A controller. The value of this register is 02h, which classifies the Am79C978A device as a networking controller.

The PCI Base-Class register is located at offset 0Bh in the PCI Configuration Space. It is read only.

PCI Latency Timer Register

Offset 0Dh

The PCI Latency Timer register is an 8-bit register that specifies the minimum guaranteed time the Am79C978A controller will control the bus once it starts its bus mastership period. The time is measured in clock cycles. Every time the Am79C978A controller asserts $\overline{\text{FRAME}}$ at the beginning of a bus mastership period, it will copy the value of the PCI Latency Timer register into a counter and start counting down. The counter will freeze at 0. When the system arbiter removes $\overline{\text{GNT}}$ while the counter is non-zero, the Am79C978A controller will continue with its data transfers. It will only release the bus when the counter has reached 0.

The PCI Latency Timer is only significant in burst transactions, where $\overline{\text{FRAME}}$ stays asserted until the last data phase. In a non-burst transaction, $\overline{\text{FRAME}}$ is only asserted during the address phase. The internal latency counter will be cleared and suspended while $\overline{\text{FRAME}}$ is deasserted.

All eight bits of the PCI Latency Timer register are programmable. The host should read the Am79C978A PCI MIN_GNT and PCI MAX_LAT registers to determine the latency requirements for the device and then initialize the Latency Timer register with an appropriate value.

The PCI Latency Timer register is located at offset 0Dh in the PCI Configuration Space. It is read and written by the host. The PCI Latency Timer register is cleared by H_RESET and is not effected by S_RESET or by setting the STOP bit.

PCI Header Type Register

Offset 0Eh

The PCI Header Type register is an 8-bit register that describes the format of the PCI Configuration Space locations 10h to 3Ch and that identifies a device to be single or multi-function. The PCI Header Type register is located at address 0Eh in the PCI Configuration Space. It is read only.

Bit	Name	Description
7	FUNCT	Single-function/multi-function device. Read as zero; write operations have no effect. The Am79C978A controller is a single function device.

6-0	LAYOUT	PCI configuration space layout. Read as zeros; write operations have no effect. The layout of the PCI configuration space locations 10h to 3Ch is as shown in Table 26.
-----	--------	---

PCI I/O Base Address Register

Offset 10h

The PCI I/O Base Address register is a 32-bit register that determines the location of the Am79C978A I/O resources in all of I/O space. It is located at offset 10h in the PCI Configuration Space.

Bit	Name	Description
31-5	IOBASE	I/O base address most significant 27 bits. These bits are written by the host to specify the location of the Am79C978A I/O resources in all of I/O space. IOBASE must be written with a valid address before the Am79C978A controller slave I/O mode is turned on by setting the IOEN bit (PCI Command register, bit 0).

When the Am79C978A controller is enabled for I/O mode (IOEN is set), it monitors the PCI bus for a valid I/O command. If the value on AD[31:5] during the address phase of the cycles matches the value of IOBASE, the Am79C978A controller will drive $\overline{\text{DEVSEL}}$ indicating it will respond to the access.

IOBASE is read and written by the host. IOBASE is cleared by H_RESET and is not affected by S_RESET or by setting the STOP bit.

4-2	IOSIZE	I/O size requirements. Read as zeros; write operations have no effect.
-----	--------	--

IOSIZE indicates the size of the I/O space the Am79C978A controller requires. When the host writes a value of FFFF FFFFh to the I/O Base Address register, it will read back a value of 0 in bits 4-2. That indicates an Am79C978A I/O space requirement of 32 bytes.

1	RES	Reserved location. Read as zero; write operations have no effect.
0	IOSPACE	I/O space indicator. Read as one; write operations have no effect. Indicating that this base address register describes an I/O base address.

PCI Memory Mapped I/O Base Address Register

Offset 14h

The PCI Memory Mapped I/O Base Address register is a 32-bit register that determines the location of the Am79C978A I/O resources in all of memory space. It is located at offset 14h in the PCI Configuration Space.

Bit	Name	Description
-----	------	-------------

31-5	MEMBASE	Memory mapped I/O base address most significant 27 bits. These bits are written by the host to specify the location of the Am79C978A I/O resources in all of memory space. MEMBASE must be written with a valid address before the Am79C978A controller slave memory mapped I/O mode is turned on by setting the MEMEN bit (PCI Command register, bit 1).
------	---------	---

When the Am79C978A controller is enabled for memory mapped I/O mode (MEMEN is set), it monitors the PCI bus for a valid memory command. If the value on AD[31:5] during the address phase of the cycles matches the value of MEMBASE, the Am79C978A controller will drive $\overline{\text{DEVSEL}}$ indicating it will respond to the access.

MEMBASE is read and written by the host. MEMBASE is cleared by H_RESET and is not affected by S_RESET or by setting the STOP bit.

4	MEMSIZE	Memory mapped I/O size requirements. Read as zeros; write operations have no effect.
---	---------	--

MEMSIZE indicates the size of the memory space the Am79C978A controller requires. When the host writes a value of FFFF FFFFh to the Memory Mapped I/O Base Address

3	PREFETCH	Prefetchable. Read as zero; write operations have no effect. Indicates that memory space controlled by this base address register is not prefetchable. Data in the memory mapped I/O space cannot be prefetched. Because one of the I/O resources in this address space is a Reset register, the order of the read accesses is important.
2-1	TYPE	Memory type indicator. Read as zeros; write operations have no effect. Indicates that this base address register is 32 bits wide and mapping can be done anywhere in the 32-bit memory space.
0	MEMSPACE	Memory space indicator. Read as zero; write operations have no effect. Indicates that this base address register describes a memory base address.

PCI Subsystem Vendor ID Register

Offset 2Ch

The PCI Subsystem Vendor ID register is a 16-bit register that together with the PCI Subsystem ID uniquely identifies the add-in card or subsystem the Am79C978A controller is used in. Subsystem Vendor IDs can be obtained from the PCI SIG. A value of 0 (the default) indicates that the Am79C978A controller does not support subsystem identification. The PCI Subsystem Vendor ID is an alias of BCR23, bits 15-0. It is programmable through the EEPROM.

The PCI Subsystem Vendor ID register is located at offset 2Ch in the PCI Configuration Space. It is read only.

PCI Subsystem ID Register

Offset 2Eh

The PCI Subsystem ID register is a 16-bit register that together with the PCI Subsystem Vendor ID uniquely identifies the add-in card or subsystem the Am79C978A controller is used in. The value of the Subsystem ID is up to the system vendor. A value of 0 (the default) indicates that the Am79C978A controller does not support subsystem identification. The PCI Subsystem ID is an alias of BCR24, bits 15-0. It is programmable through the EEPROM.

The PCI Subsystem ID register is located at offset 2Eh in the PCI Configuration Space. It is read only.

PCI Expansion ROM Base Address Register

Offset 30h

The PCI Expansion ROM Base Address register is a 32-bit register that defines the base address, size, and address alignment of an Expansion ROM. It is located at offset 30h in the PCI Configuration Space.

Bit	Name	Description
31-20	ROMBASE	<p>Expansion ROM base address most significant 12 bits. These bits are written by the host to specify the location of the Expansion ROM in all of memory space. ROMBASE must be written with a valid address before the Am79C978A Expansion ROM access is enabled by setting ROMEN (PCI Expansion ROM Base Address register, bit 0) and MEMEN (PCI Command register, bit 1).</p> <p>Since the 12 most significant bits of the base address are programmable, the host can map the Expansion ROM on any 1M boundary.</p> <p>When the Am79C978A controller is enabled for Expansion ROM access (ROMEN and MEMEN are set to 1), it monitors the PCI bus for a valid memory command. If the value on AD[31:2] during the address phase of the cycle falls between ROMBASE and ROMBASE + 1M - 4, the Am79C978A controller will drive $\overline{\text{DEVSEL}}$ indicating it will respond to the access.</p> <p>ROMBASE is read and written by the host. ROMBASE is cleared by H_RESET and is not affected by S_RESET or by setting the STOP bit.</p>
19-1	ROMSIZE	<p>ROM size. Read as zeros; write operation have no effect. ROMSIZE indicates the maximum size of the Expansion ROM the Am79C978A controller can support. The host can determine the Expansion ROM size by writing FFFF FFFFh to the Expansion</p>

ROM Base Address register. It will read back a value of 0 in bit 19-1, indicating an Expansion ROM size of 1M.

Note that ROMSIZE only specifies the maximum size of Expansion ROM the Am79C978A controller supports. A smaller ROM can also be used. The actual size of the code in the Expansion ROM is always determined by reading the Expansion ROM header.

0	ROMEN	<p>Expansion ROM Enable. Written by the host to enable access to the Expansion ROM. The Am79C978A controller will only respond to accesses to the Expansion ROM when both ROMEN and MEMEN (PCI Command register, bit 1) are set to 1.</p> <p>ROMEN is read and written by the host. ROMEN is cleared by H_RESET and is not effected by S_RESET or by setting the STOP bit.</p>
---	-------	--

PCI Capabilities Pointer Register

Offset 34h

Bit	Name	Description
7-0	CAP_PTR	<p>The PCI Capabilities Pointer register is an 8-bit register that points to a linked list of capabilities implemented on this device. This register has a default value of 40h.</p> <p>The PCI Capabilities Pointer register is located at offset 34h in the PCI Configuration Space. It is read only.</p>

PCI Interrupt Line Register

Offset 3Ch

The PCI Interrupt Line register is an 8-bit register that is used to communicate the routing of the interrupt. This register is written by the POST software as it initializes the Am79C978A controller in the system. The register is read by the network driver to determine the interrupt channel which the POST software has assigned to the Am79C978A controller. The PCI Interrupt Line register is not modified by the Am79C978A controller. It has no effect on the operation of the device.

The PCI Interrupt Line register is located at offset 3Ch in the PCI Configuration Space. It is read and written by the host. It is cleared by H_RESET and is not affected by S_RESET or by setting the STOP bit.

PCI Interrupt Pin Register

Offset 3Dh

This PCI Interrupt Pin register is an 8-bit register that indicates the interrupt pin that the Am79C978A controller is using. The value for the Am79C978A Interrupt Pin register is 01h, which corresponds to INTA.

The PCI Interrupt Pin register is located at offset 3Dh in the PCI Configuration Space. It is read only.

PCI MIN_GNT Register

Offset 3Eh

The PCI MIN_GNT register is an 8-bit register that specifies the minimum length of a burst period that the Am79C978A device needs to keep up with the network activity. The length of the burst period is calculated assuming a clock rate of 33 MHz. The register value specifies the time in units of 1/4 μs. The PCI MIN_GNT register is an alias of BCR22, bits 7-0. It is recommended that BCR22 be programmed to a value of 1818h.

The host should use the value in this register to determine the setting of the PCI Latency Timer register.

The PCI MIN_GNT register is located at offset 3Eh in the PCI Configuration Space. It is read only.

PCI MAX_LAT Register

Offset 3Fh

The PCI MAX_LAT register is an 8-bit register that specifies the maximum arbitration latency the Am79C978A controller can sustain without causing problems to the network activity. The register value specifies the time in units of 1/4 μs. The MAX_LAT register is an alias of BCR22, bits 15-8. It is recommended that BCR22 be programmed to a value of 1818h.

The host should use the value in this register to determine the setting of the PCI Latency Timer register.

The PCI MAX_LAT register is located at offset 3Fh in the PCI Configuration Space. It is read only.

PCI Capability Identifier Register

Offset 40h

Bit	Name	Description
7-0	CAP_ID	This register, when set to 1, identifies the linked list item as being the PCI Power Management registers. This register has a default value of 1h. The PCI Capabilities Identifier register is located at offset 40h in

the PCI Configuration Space. It is read only.

PCI Next Item Pointer Register

Offset 41h

Bit	Name	Description
7-0	NXT_ITM_PTR	The Next Item Pointer Register points to the starting address of the next capability. The pointer at this offset is a null pointer, indicating that this is the last capability in the linked list of the capabilities. This register has a default value of 0h. The PCI Next Pointer Register is located at offset 41h in the PCI Configuration Space. It is read only.

PCI Power Management Capabilities Register (PMC)

Offset 42h

Note: All bits of this register are loaded from the EEPROM. The register is aliased to BCR36 for testing purposes.

Bit	Name	Description
15-11	PME_SPT	PME Support. This 5-bit field indicates the power states in which the function may assert \overline{PME} . A value of 0b for any bit indicates that the function is not capable of asserting the \overline{PME} signal while in that power state. Bit(11) XXXX1b – \overline{PME} can be asserted from D0. Bit(12) XXX1Xb – \overline{PME} can be asserted from D1. Bit(13) XX1XXb – \overline{PME} can be asserted from D2. Bit(14) X1XXXb – \overline{PME} can be asserted from D3 _{hot} . Bit(15) 1XXXXb – \overline{PME} can be asserted from D3 _{cold} . PME_SPT is read only.

10	D2_SPT	<p>D2 Support. If this bit is a 1, this function supports the D2 Power Management State.</p> <p>This bit is read only.</p>	4	RES	<p>Reserved location.</p>
9	D1_SPT	<p>D1 Support. If this bit is a 1, this function supports the D1 Power Management State.</p> <p>This bit is read only.</p>	3	PME_CLK	<p>PME Clock. When this bit is a 1, it indicates that the function relies on the presence of the PCI clock for $\overline{\text{PME}}$ operation. When this bit is a 0 it indicates that no PCI clock is required for the function to generate $\overline{\text{PME}}$.</p> <p>Functions that do not support $\overline{\text{PME}}$ generation in any state must return 0 for this field.</p> <p>This bit is read only.</p>
8-6	AUX_CURRENT	<p>Auxiliary Current Requirements. This 3-bit field reports the 3.3Vaux current requirements for the PCI function. If the Data Register has been implemented by this function, then reads of this field must return a value of 000b and the Data Register will take precedence over this field for 3.3Vaux current requirement reporting.</p> <p>If $\overline{\text{PME}}$ generation from D3_{cold} is not supported by the function (PMC (15) = 0), this field must return a value of 000b when read.</p> <p>For functions that support $\overline{\text{PME}}$ from D3_{cold} and do not implement the Data Register, the following bit assignments apply:</p>	2-0	PMIS_VER	<p>Power Management Interface Specification Version. A value of 001b indicates that this function complies with revision 1.0 of the PCI Power Management Interface Specification.</p>

Bit 8 7 6	3.3Vaux Max. Current Required
1 1 1	375 mA
1 1 0	320 mA
1 0 1	270 mA
1 0 0	220 mA
0 1 1	160 mA
0 1 0	100 mA
0 0 1	55 mA
0 0 0	0 (self-powered)

These bits are read only.

5	DSI	<p>Device Specific Initialization. When this bit is 1, it indicates that special initialization of the function is required (beyond the standard PCI configuration header)</p>
---	-----	--

PCI Power Management Control/Status Register (PMCSR)

Offset 44h

Bit	Name	Description
-----	------	-------------

15	PME_STATUS	<p>PME Status. This bit is set when the function would normally assert the $\overline{\text{PME}}$ signal independent of the state of the PME_EN bit.</p>
----	------------	--

Writing a 1 to this bit will clear it and cause the function to stop asserting a $\overline{\text{PME}}$ (if enabled). Writing a 0 has no effect.

If the function supports $\overline{\text{PME}}$ from D3_{cold}, then this bit is sticky and must be explicitly cleared by the operating system each time the operating system is initially loaded.

This bit is always read/write accessible. Sticky bit. This bit is reset by POR, H_RESET, S_RESET, or setting the STOP bit has no effect.

14-13 DATA_SCALE

Data Scale. This 2-bit read-only field indicates the scaling factor to be used when interpreting the value of the Data register. The value and meaning of this field will vary depending on the DATA_SCALE field.

These bits are read only.

12-9 DATA_SEL Data Select. This optional 4-bit field is used to select which data is reported through the Data register and DATA_SCALE field.

These bits are always read/write accessible. Sticky bit. These bits are reset by POR, H_RESET, S_RESET, or setting the STOP bit has no effect.

8 PME_ENPME Enable. When a 1, PME_EN enables the function to assert \overline{PME} . When a 0, \overline{PME} assertion is disabled.

This bit defaults to “0” if the function does not support \overline{PME} generation from D3_{cold}.

If the function supports \overline{PME} from D3_{cold}, then this bit is sticky and must be explicitly cleared by the operating system each time the operating system is initially loaded.

This bit is always read/write accessible. Sticky bit. This bit is reset by POR, H_RESET, S_RESET, or setting the STOP bit has no effect.

7-2 RESReserved locations. These bits are read only.

1-0 PWR_STATEPower State. This 2-bit field is used both to determine the current power state of a function and to set the function into a new power state. The definition of the field values is given below.

- 00b - D0
- 01b - D1
- 10b - D2
- 11b - D3

These bits can be written and read, but their contents have no effect on the operation of the device.

These bits are always read/write accessible.

PCI PMCSR Bridge Support Extensions Register

Offset 46h

Bit	Name	Description
7-0	PMCSR_BSE	The PCI PMCSR Bridge Support Extensions Register is an 8-bit register. PMCSR Bridge Support Extensions are not supported. This register has a default value of 00h. The PCI PMCSR Bridge Support Extensions register is located at offset 46h in the PCI Configuration Space. These bits are read only.

PCI Data Register

Offset 47h

Note: All bits of this register are loaded from the EEPROM. The register is aliased to lower bytes of the BCR37-BCR44 for testing purposes.

Bit	Name	Description
7-0	DATA_REG	The PCI Data Register is an 8-bit register. Refer to the “PCI Bus Power Management Interface Specification” version 1.0 for a more detailed description of this register. The PCI DATA register is located at offset 47h in the PCI Configuration Space. It is read only.

RAP Register

The RAP (Register Address Pointer) register is used to gain access to CSR and BCR registers on board the Am79C978A controller. The RAP contains the address of a CSR or BCR.

As an example of RAP use, consider a read access to CSR4. In order to access this register, it is necessary to first load the value 0004h into the RAP by performing a write access to the RAP offset of 12h (12h when WIO mode has been selected, 14h when DWIO mode has been selected). Then a second access is performed, this time to the RDP offset of 10h (for either WIO or

DWIO mode). The RDP access is a read access, and since RAP has just been loaded with the value of 0004h, the RDP read will yield the contents of CSR4. A read of the BDP at this time (offset of 16h when WIO mode has been selected, 1Ch when DWIO mode has been selected) will yield the contents of BCR4, since the RAP is used as the pointer into both BDP and RDP space.

RAP: Register Address Port

Bit	Name	Description
31-16	RES	Reserved locations. Written as zeros and read as undefined.
15-8	RES	Reserved locations. Read and written as zeros.
7-0	RAP	<p>Register Address Port. The value of these 8 bits determines which CSR or BCR will be accessed when an I/O access to the RDP or BDP port, respectively, is performed.</p> <p>A write access to undefined CSR or BCR locations may cause unexpected reprogramming of the Am79C978A control registers. A read access will yield undefined values.</p> <p>These bits are always read/write accessible. RAP is cleared by H_RESET or S_RESET and is unaffected by setting the STOP bit.</p>

Control and Status Registers (CSRs)

The CSR space is accessible by performing accesses to the RDP (Register Data Port). The particular CSR that is read or written during an RDP access will depend upon the current setting of the RAP. RAP serves as a pointer into the CSR space.

CSR0: Controller Status and Control Register

Certain bits in CSR0 indicate the cause of an interrupt. The register is designed so that these indicator bits are cleared by writing ones to those bit locations. This means that the software can read CSR0 and write back the value just read to clear the interrupt condition.

Bit	Name	Description
31-16	RES	Reserved locations. Written as zeros and read as undefined.
15	ERR	Error. Error is set by the OR of CERR, MISS, and MERR. ERR remains set as long as any of the error flags are true.

This bit is always read accessible only. Write operations are ignored.

14 RES Reserved locations. This bit is always read/write accessible. Read returns zero.

13 CERR Collision Error. Collision Error is set by the Am79C978A controller when the device operates in half-duplex mode and the collision inputs to the GPSI port fail to activate within 20 network bit times after the chip terminates transmission (SQE Test). This feature is a transceiver test feature. CERR reporting is disabled when the GPSI port is active and the Am79C978A controller operates in full-duplex mode.

When the MII port is selected, CERR is only reported when the external PHY is operating as a half-duplex 10BASE-T PHY.

CERR assertion will not result in an interrupt being generated. CERR assertion will set the ERR bit.

This bit is always read/write accessible. CERR is cleared by the host by writing a 1. Writing a 0 has no effect. CERR is cleared by H_RESET, S_RESET, or by setting the STOP bit.

12 MISS Missed Frame. Missed Frame is set by the Am79C978A controller when it has lost an incoming receive frame resulting from a Receive Descriptor not being available. This bit is the only immediate indication that receive data has been lost since there is no current receive descriptor. The Missed Frame Counter (CSR112) also increments each time a receive frame is missed.

When MISS is set, \overline{INTA} is asserted if IENA is 1 and the mask bit MISSM (CSR3, bit 12) is 0. MISS assertion will set the ERR bit, regardless of the settings of IENA and MISSM.

		<p>This bit is always read/write accessible. MISS is cleared by the host by writing a 1. Writing a 0 has no effect. MISS is cleared by H_RESET, S_RESET, or by setting the STOP bit.</p>	9	TINT	<p>Transmit Interrupt is set by the Am79C978A controller after the OWN bit in the last descriptor of a transmit frame has been cleared to indicate the frame has been sent or an error occurred in the transmission.</p> <p>When TINT is set, $\overline{\text{INTA}}$ is asserted if IENA is 1 and the mask bit TINTM (CSR3, bit 9) is 0.</p> <p>TINT will not be set if TINTOKD (CSR5, bit 15) is set to 1 and the transmission was successful.</p> <p>This bit is always read/write accessible. TINT is cleared by the host by writing a 1. Writing a 0 has no effect. TINT is cleared by H_RESET, S_RESET, or by setting the STOP bit.</p>
11	MERR	<p>Memory Error. Memory Error is set by the Am79C978A controller when it requests the use of the system interface bus by asserting $\overline{\text{REQ}}$ and has not received $\overline{\text{GNT}}$ assertion after a programmable length of time. The length of time in microseconds before MERR is asserted will depend upon the setting of the Bus Timeout Register (CSR100). The default setting of CSR100 will give a MERR after 153.6 ms of bus latency.</p> <p>When MERR is set, $\overline{\text{INTA}}$ is asserted if IENA is 1 and the mask bit MERRM (CSR3, bit 11) is 0. MERR assertion will set the ERR bit, regardless of the settings of IENA and MERRM.</p> <p>This bit is always read/write accessible. MERR is cleared by the host by writing a 1. Writing a 0 has no effect. MERR is cleared by H_RESET, S_RESET, or by setting the STOP bit.</p>			
			8	IDON	<p>Initialization Done is set by the Am79C978A controller after the initialization sequence has completed. When IDON is set, the Am79C978A controller has read the initialization block from memory.</p> <p>When IDON is set, $\overline{\text{INTA}}$ is asserted if IENA is 1 and the mask bit IDONM (CSR3, bit 8) is 0.</p>
10	RINT	<p>Receive Interrupt is set by the Am79C978A controller after the last descriptor of a receive frame has been update by writing a 0 to the ownership bit (OWN). RINT may also be set when the first descriptor of a receive frame has been updated by writing a 0 to the ownership bit if the LAPPEN bit of CSR3 has been set to a 1.</p> <p>When RINT is set, $\overline{\text{INTA}}$ is asserted if IENA is 1 and the mask bit RINTM (CSR3, bit 10) is 0.</p> <p>This bit is always read/write accessible. RINT is cleared by the host by writing a 1. Writing a 0 has no effect. RINT is cleared by H_RESET, S_RESET, or by setting the STOP bit.</p>			<p>This bit is always read/write accessible. IDON is cleared by the host by writing a 1. Writing a 0 has no effect. IDON is cleared by H_RESET, S_RESET, or by setting the STOP bit.</p>
			7	INTR	<p>Interrupt Flag indicates that one or more following interrupt causing conditions has occurred: EXDINT, IDON, MERR, MISS, MFCO, RCVCCO, RINT, SINT, TINT, TXSTRT, UINT, STINT, MREINT, MCCINT, MIIPDTINT, MAPINT and the associated mask or enable bit is programmed to allow the event to cause an interrupt. If IENA is set to 1 and INTR is set, $\overline{\text{INTA}}$ will be active. When INTR is set by SINT or SLPINT, $\overline{\text{INTA}}$ will be active independent of the state of IENA.</p>

		<p>This bit is always read accessible. INTR is read only. INTR is cleared by clearing all of the active individual interrupt bits that have not been masked out.</p>			<p>will be reset and no Transmit Descriptor Ring access will occur.</p>
6	IENA	<p>Interrupt Enable allows $\overline{\text{INTA}}$ to be active if the Interrupt Flag is set. If IENA = 0, then $\overline{\text{INTA}}$ will be disabled regardless of the state of INTR.</p> <p>This bit is always read/write accessible. IENA is set by writing a 1 and cleared by writing a 0. IENA is cleared by H_RESET or S_RESET and setting the STOP bit.</p>			<p>TDMD is required to be set if the TXDPOLL bit in CSR4 is set. Setting TDMD while TXDPOLL = 0 merely hastens the controller's response to a Transmit Descriptor Ring Entry.</p> <p>This bit is always read/write accessible. TDMD is set by writing a 1. Writing a 0 has no effect. TDMD will be cleared by the Buffer Management Unit when it fetches a Transmit Descriptor. TDMD is cleared by H_RESET or S_RESET and setting the STOP bit.</p>
5	RXON	<p>Receive On indicates that the receive function is enabled. RXON is set if DRX (CSR15, bit 0) is set to 0 after the START bit is set. If INIT and START are set together, RXON will not be set until after the initialization block has been read in.</p> <p>This bit is always read accessible. RXON is read only. RXON is cleared by H_RESET or S_RESET and setting the STOP bit.</p>	2	STOP	<p>STOP assertion disables the chip from all DMA activity. The chip remains inactive until either STRT or INIT are set. If STOP, STRT, and INIT are all set together, STOP will override STRT and INIT.</p> <p>This bit is always read/write accessible. STOP is set by writing a 1, by H_RESET or S_RESET. Writing a 0 has no effect. STOP is cleared by setting either STRT or INIT.</p>
4	TXON	<p>Transmit On indicates that the transmit function is enabled. TXON is set if DTX (CSR15, bit 1) is set to 0 after the START bit is set. If INIT and START are set together, TXON will not be set until after the initialization block has been read in.</p> <p>This bit will reset if the DXSUFLO bit (CSR3, bit 6) is reset and there is an underflow condition encountered.</p> <p>Read accessible always. TXON is read only. TXON is cleared by H_RESET or S_RESET and setting the STOP bit.</p>	1	STRT	<p>STRT assertion enables the Am79C978A controller to send and receive frames and perform buffer management operations. Setting STRT clears the STOP bit. If STRT and INIT are set together, the Am79C978A controller initialization will be performed first.</p> <p>This bit is always read/write accessible. STRT is set by writing a 1. Writing a 0 has no effect. STRT is cleared by H_RESET, S_RESET, or by setting the STOP bit.</p>
3	TDMD	<p>Transmit Demand, when set, causes the Buffer Management Unit to access the Transmit Descriptor Ring without waiting for the poll-time counter to elapse. If TXON is not enabled, TDMD bit</p>	0	INIT	<p>INIT assertion enables the Am79C978A controller to begin the initialization procedure which reads in the initialization block from memory. Setting INIT clears the STOP bit. If STRT and INIT are set together, the Am79C978A</p>

controller initialization will be performed first. INIT is not cleared when the initialization sequence has completed.

This bit is always read/write accessible. INIT is set by writing a 1. Writing a 0 has no effect. INIT is cleared by H_RESET, S_RESET, or by setting the STOP bit.

CSR1: Initialization Block Address 0

Bit	Name	Description
31-16	RES	Reserved locations. Written as zeros and read as undefined.
15-0	IADR[15:0]	Lower 16 bits of the address of the Initialization Block. Bit locations 1 and 0 must both be 0 to align the initialization block to a DWord boundary. This register is aliased with CSR16. These bits are read/write accessible only when either the STOP or the SPND bit is set. These bits are unaffected by H_RESET, S_RESET, or by setting the STOP bit.

CSR2: Initialization Block Address 1

Bit	Name	Description
31-16	RES	Reserved locations. Written as zeros and read as undefined.
15-8	IADR[31:24]	If SSIZE32 is set (BCR20, bit 8), then the IADR[31:24] bits will be used strictly as the upper 8 bits of the initialization block address. However, if SSIZE32 is reset (BCR20, bit 8), then the IADR[31:24] bits will be used to generate the upper 8 bits of all bus mastering addresses, as required for a 32-bit address bus. Note that the 16-bit software structures specified by the SSIZE32 = 0 setting will yield only 24 bits of address for the Am79C978A bus master accesses, while the 32-bit hardware for which the Am79C978A

controller is intended will require 32 bits of address. Therefore, whenever SSIZE32 = 0, the IADR[31:24] bits will be appended to the 24-bit initialization address, to each 24-bit descriptor base address, and to each beginning 24-bit buffer address in order to form complete 32-bit addresses. The upper 8 bits that exist in the descriptor address registers and the buffer address registers which are stored on board the Am79C978A controller will be overwritten with the IADR[31:24] value, so that CSR accesses to these registers will show the 32-bit address that includes the appended field.

If SSIZE32 = 1, then software will provide 32-bit pointer values for all of the shared software structures – i.e., descriptor bases and buffer addresses, and therefore, IADR[31:24] will not be written to the upper 8 bits of any of these resources, but it will be used as the upper 8 bits of the initialization address.

This register is aliased with CSR17.

These bits are read/write accessible only when either the STOP or the SPND bit is set. These bits are unaffected by H_RESET, S_RESET, or by setting the STOP bit.

7-0 IADR[23:16] Bits 23 through 16 of the address of the Initialization Block. Whenever this register is written, CSR17 is updated with CSR2's contents.

These bits are read/write accessible only when either the STOP or the SPND bit is set. These bits are unaffected by H_RESET, S_RESET, or by setting the STOP bit.

CSR3: Interrupt Masks and Deferral Control

Bit	Name	Description
31-16	RES	Reserved locations. Written as zeros and read as undefined.
15-13	RES	Reserved locations. Read and written as zero.
12	MISSM	<p>Missed Frame Mask. If MISSM is set, the MISS bit will be masked and unable to set the INTR bit.</p> <p>This bit is always read/write accessible. MISSM is cleared by H_RESET or S_RESET and is not affected by STOP.</p>
11	MERRM	<p>Memory Error Mask. If MERRM is set, the MERR bit will be masked and unable to set the INTR bit.</p> <p>This bit is always read/write accessible. MERRM is cleared by H_RESET or S_RESET and is not affected by STOP.</p>
10	RINTM	<p>Receive Interrupt Mask. If RINTM is set, the RINT bit will be masked and unable to set the INTR bit.</p> <p>This bit is always read/write accessible. RINTM is cleared by H_RESET or S_RESET and is not affected by STOP.</p>
9	TINTM	<p>Transmit Interrupt Mask. If TINTM is set, the TINT bit will be masked and unable to set the INTR bit.</p> <p>This bit is always read/write accessible. TINTM is cleared by H_RESET or S_RESET and is not affected by STOP.</p>
8	IDONM	<p>Initialization Done Mask. If IDONM is set, the IDON bit will be masked and unable to set the INTR bit.</p> <p>This bit is always read/write accessible. IDONM is cleared by H_RESET or S_RESET and is not affected by STOP.</p>
7	RES	Reserved location. Read and written as zero.

6	DXSUFLO	<p>Disable Transmit Stop on Underflow error.</p> <p>When DXSUFLO (CSR3, bit 6) is set to 0, the transmitter is turned off when an UFLO error occurs (CSR0, TXON = 0).</p> <p>When DXSUFLO is set to 1, the Am79C978A controller gracefully recovers from an UFLO error. It scans the transmit descriptor ring until it finds the start of a new frame and starts a new transmission.</p> <p>This bit is always read/write accessible. DXSUFLO is cleared by H_RESET or S_RESET and is not affected by STOP.</p>
5	LAPPEN	<p>Look Ahead Packet Processing Enable. When set to a 1, the LAPPEN bit will cause the Am79C978A controller to generate an interrupt following the descriptor write operation to the first buffer of a receive frame. This interrupt will be generated in addition to the interrupt that is generated following the descriptor write operation to the last buffer of a receive packet. The interrupt will be signaled through the RINT bit of CSR0.</p> <p>Setting LAPPEN to a 1 also enables the Am79C978A controller to read the STP bit of receive descriptors. The Am79C978A controller will use the STP information to determine where it should begin writing a receive packet's data. Note that while in this mode, the Am79C978A controller can write intermediate packet data to buffers whose descriptors do not contain STP bits set to 1. Following the write to the last descriptor used by a packet, the Am79C978A controller will scan through the next descriptor entries to locate the next STP bit that is set to a 1. The Am79C978A controller will begin writing the next packets data to the buffer pointed to by that descriptor.</p>

Note that because several descriptors may be allocated by the host for each packet, and not all messages may need all of the descriptors that are allocated between descriptors that contain STP = 1, then some descriptors/buffers may be skipped in the ring. While performing the search for the next STP bit that is set to 1, the Am79C978A controller will advance through the receive descriptor ring regardless of the state of ownership bits. If any of the entries that are examined during this search indicate Am79C978A controller ownership of the descriptor but also indicate STP = 0, then the Am79C978A controller will reset the OWN bit to 0 in these entries. If a scanned entry indicates host ownership with STP = 0, then the Am79C978A controller will not alter the entry, but will advance to the next entry.

When the STP bit is found to be true, but the descriptor that contains this setting is not owned by the Am79C978A controller, then the Am79C978A controller will stop advancing through the ring entries and begin periodic polling of this entry. When the STP bit is found to be true, and the descriptor that contains this setting is owned by the Am79C978A controller, then the controller will stop advancing through the ring entries, store the descriptor information that it has just read, and wait for the next receive to arrive.

This behavior allows the host software to pre-assign buffer space in such a manner that the header portion of a receive packet will always be written to a particular memory area, and the data portion of a receive packet will always be written to a separate memory area. The interrupt is generated when the header bytes have been written to the header memory area.

4	DXMT2PD	<p>This bit is always read/write accessible. The LAPPEN bit will be reset to 0 by H_RESET or S_RESET and will be unaffected by STOP.</p> <p>See Appendix B for more information on the Look Ahead Packet Processing concept.</p> <p>Disable Transmit Two Part Deferral (see Medium Allocation section in the <i>Media Access Management</i> section for more details). If DXMT2PD is set, Transmit Two Part Deferral will be disabled.</p> <p>This bit is always read/write accessible. DXMT2PD is cleared by H_RESET or S_RESET and is not affected by STOP.</p>
3	EMBA	<p>Enable Modified Back-off Algorithm (see the <i>Contention Resolution</i> section in <i>Media Access Management</i> section for more details). If EMBA is set, a modified back-off algorithm is implemented.</p> <p>This bit is always read/write accessible. EMBA is cleared by H_RESET or S_RESET and is not affected by STOP.</p>
2	BSWP	<p>Byte Swap. This bit is used to choose between big and little Endian modes of operation. When BSWP is set to a 1, big Endian mode is selected. When BSWP is set to 0, little Endian mode is selected.</p> <p>When big Endian mode is selected, the Am79C978A controller will swap the order of bytes on the AD bus during a data phase on accesses to the FIFOs only. Specifically, AD[31:24] becomes Byte 0, AD[23:16] becomes Byte 1, AD[15:8] becomes Byte 2, and AD[7:0] becomes Byte 3 when big Endian mode is selected. When little Endian mode is selected, the order of bytes on the AD bus during a data phase is: AD[31:24] is Byte 3, AD[23:16] is Byte 2,</p>

AD[15:8] is Byte 1, and AD[7:0] is Byte 0.

Byte swap only affects data transfers that involve the FIFOs. Initialization block transfers are not affected by the setting of the BSWP bit. Descriptor transfers are not affected by the setting of the BSWP bit. RDP, RAP, BDP and PCI configuration space accesses are not affected by the setting of the BSWP bit. Address PROM transfers and Expansion ROM accesses are not affected by the setting of the BSWP bit.

Note that the byte ordering of the PCI bus is defined to be little Endian. BSWP should not be set to 1 when the Am79C978A controller is used in a PCI bus application.

This bit is always read/write accessible. BSWP is cleared by H_RESET or S_RESET and is not affected by STOP.

1-0 RES Reserved locations. The default values of these bits are zeros. Writing a 1 to this bit has no effect on device function. If a 1 is written to these bits, then a 1 will be read back. Existing drivers may write a 1 to these bits for compatibility, but new drivers should write a 0 to these bits and should treat the read value as undefined.

This bit is always read/write accessible. This bit is cleared by H_RESET or S_RESET and is unaffected by the STOP bit.

14 DMAPLUS Writing and reading from this bit has no effect. DMAPLUS is always set to 1.

13 RES Reserved Location. Written as zero and read as undefined.

12 TXDPOLL Disable Transmit Polling. If TXDPOLL is set, the Buffer Management Unit will disable transmit polling. Likewise, if TXDPOLL is cleared, automatic transmit polling is enabled. If TXDPOLL is set, TDMD bit in CSR0 must be set in order to initiate a manual poll of a transmit descriptor. Transmit descriptor polling will not take place if TXON is reset. Transmit polling will take place following Receive activities.

This bit is always read/write accessible. TXDPOLL is cleared by H_RESET or S_RESET and is unaffected by the STOP bit.

11 APAD_XMT Auto Pad Transmit. When set, APAD_XMT enables the automatic padding feature. Transmit frames will be padded to extend them to 64 bytes including FCS. The FCS is calculated for the entire frame, including pad, and appended after the pad field. APAD_XMT will override the programming of the DXMTFCS bit (CSR15, bit 3) and of the ADD_FCS bit (TMD1, bit 29).

This bit is always read/write accessible. APAD_XMT is cleared by H_RESET or S_RESET and is unaffected by the STOP bit.

CSR4: Test and Features Control

Certain bits in CSR4 indicate the cause of an interrupt. The register is designed so that these indicator bits are cleared by writing ones to those bit locations. This means that the software can read CSR4 and write back the value just read to clear the interrupt condition.

Bit	Name	Description
31-16	RES	Reserved locations. Written as zeros and read as undefined.
15	RES	Reserved location. It is OK for legacy software to write a 1 to this location. This bit must be set back to 0 before setting INIT or STRT bits.

10 ASTRP_RCV Auto Strip Receive. When set, ASTRP_RCV enables the automatic pad stripping feature. The pad and FCS fields will be stripped from receive frames and not placed in the FIFO.

This bit is always read/write accessible. ASTRP_RCV is cleared

		by H_RESET or S_RESET and is unaffected by the STOP bit.			controller when the Receive Collision Counter (CSR114 and CSR115) has wrapped around.
9	MFCO	<p>Missed Frame Counter Overflow is set by the Am79C978A controller when the Missed Frame Counter (CSR112 and CSR113) has wrapped around.</p> <p>When MFCO is set, \overline{INTA} is asserted if IENA is 1 and the mask bit MFCOM is 0.</p> <p>This bit is always read/write accessible. MFCO is cleared by the host by writing a 1. Writing a 0 has no effect. MFCO is cleared by H_RESET, S_RESET, or by setting the STOP bit.</p>			<p>When RCVCCO is set, \overline{INTA} is asserted if IENA is 1 and the mask bit RCVCCOM is 0.</p> <p>This bit is always read/write accessible. RCVCCO is cleared by the host by writing a 1. Writing a 0 has no effect. RCVCCO is cleared by H_RESET, S_RESET, or by setting the STOP bit.</p>
8	MFCOM	<p>Missed Frame Counter Overflow Mask. If MFCOM is set, the MFCO bit will be masked and unable to set the INTR bit.</p> <p>This bit is always read/write accessible. MFCOM is set to 1 by H_RESET or S_RESET and is not affected by the STOP bit.</p>	4	RCVCCOM	<p>Receive Collision Counter Overflow Mask. If RCVCCOM is set, the RCVCCO bit will be masked and unable to set the INTR bit.</p> <p>This bit is always read/write accessible. RCVCCOM is set to 1 by H_RESET or S_RESET and is not affected by the STOP bit.</p>
7	UINTCMD	<p>User Interrupt Command. UINTCMD can be used by the host to generate an interrupt unrelated to any network activity. When UINTCMD is set, \overline{INTA} is asserted if IENA is set to 1. Write a 1 to UINT to clear UINTCMD and stop interrupts.</p> <p>This bit is always read/write accessible. UINTCMD is cleared by H_RESET or S_RESET or by setting the STOP bit.</p>	3	TXSTRT	<p>Transmit Start status is set by the Am79C978A controller whenever it begins transmission of a frame.</p> <p>When TXSTRT is set, \overline{INTA} is asserted if IENA is 1 and the mask bit TXSTRM is 0.</p> <p>This bit is always read/write accessible. TXSTRT is cleared by the host by writing a 1. Writing a 0 has no effect. TXSTRT is cleared by H_RESET, S_RESET, or by setting the STOP bit.</p>
6	UINT	<p>User Interrupt. UINT is set by the Am79C978A controller after the host has issued a user interrupt command by setting UINTCMD (CSR4, bit 7) to 1.</p> <p>This bit is always read/write accessible. UINT is cleared by the host by writing a 1. Writing a 0 has no effect. UINT is cleared by H_RESET or S_RESET or by setting the STOP bit.</p>	2	TXSTRM	<p>Transmit Start Mask. If TXSTRM is set, the TXSTRT bit will be masked and unable to set the INTR bit.</p> <p>This bit is always read/write accessible. TXSTRM is set to 1 by H_RESET or S_RESET and is not affected by the STOP bit.</p>
5	RCVCCO	<p>Receive Collision Counter Overflow is set by the Am79C978A</p>	1-0	RES	<p>Reserved locations. Written as zeros and read as undefined.</p>

CSR5: Extended Control and Interrupt 1

Certain bits in CSR5 indicate the cause of an interrupt. The register is designed so that these indicator bits are cleared by writing ones to those bit locations. This

means that the software can read CSR5 and write back the value just read to clear the interrupt condition.

Bit	Name	Description
31-16	RES	Reserved locations. Written as zeros and read as undefined.
15	TOKINTD	<p>Transmit OK Interrupt Disable. If TOKINTD is set to 1, the TINT bit in CSR0 will not be set when a transmission was successful. Only a transmit error will set the TINT bit.</p> <p>TOKINTD has no effect when LTINTEN (CSR5, bit 14) is set to 1. A transmit descriptor with LTINT set to 1 will always cause TINT to be set to 1, independent of the success of the transmission.</p> <p>This bit is always read/write accessible. TOKINTD is cleared by H_RESET or S_RESET and is unaffected by STOP.</p>
14	LTINTEN	<p>Last Transmit Interrupt Enable. When set to 1, the LTINTEN bit will cause the Am79C978A controller to read bit 28 of TMD1 as LTINT. The setting LTINT will determine if TINT will be set at the end of the transmission.</p> <p>This bit is always read/write accessible. LTINTEN is cleared by H_RESET or S_RESET and is unaffected by STOP.</p>
13-12	RES	Reserved locations. Written as zeros and read as undefined.
11	SINT	<p>System Interrupt is set by the Am79C978A controller when it detects a system error during a bus master transfer on the PCI bus. System errors are data parity error, master abort, or a target abort. The setting of SINT due to data parity error is not dependent on the setting of PERREN (PCI Command register, bit 6).</p> <p>When SINT is set, \overline{INTA} is asserted if the enable bit SINTE is 1. Note that the assertion of an interrupt due to SINT is not dependent on the state of the INEA bit, since INEA is cleared by the STOP reset generated by the system error.</p>
10	SINTE	System Interrupt Enable. If SINTE is set, the SINT bit will be able to set the INTR bit.
9-8	RES	Reserved locations. Written as zeros and read as undefined.
7	EXDINT	Excessive Deferral Interrupt is set by the Am79C978A controller when the transmitter has experienced Excessive Deferral on a transmit frame, where Excessive Deferral is defined in the ISO 8802-3 (IEEE/ANSI 802.3) standard.
6	EXDINTE	Excessive Deferral Interrupt Enable. If EXDINTE is set, the EXDINT bit will be able to set the INTR bit.

		This bit is always read/write accessible. EXDINTE is set to 0 by H_RESET and is not affected by S_RESET or setting the STOP bit.			by H_RESET or S_RESET and is not affected by setting the STOP bit.
5	MPPLBA	Magic Packet Physical Logical Broadcast Accept. If MPPLBA is at its default value of 0, the Am79C978A controller will only detect a Magic Packet frame if the destination address of the packet matches the content of the physical address register (PADR). If MPPLBA is set to 1, the destination address of the Magic Packet frame can be unicast, multicast, or broadcast. Note that the setting of MPPLBA only affects the address detection of the Magic Packet frame. The Magic Packet frame's data sequence must be made up of 16 consecutive physical addresses (PADR[47:0]) regardless of what kind of destination address it has. This bit is OR'ed with the EMPPLBA bit (CSR116, bit 6).	2	MPEN	Magic Packet Enable. MPEN allows activation of the Magic Packet mode by the host. The Am79C978A controller will enter the Magic Packet mode when both MPEN and MPMODE are set to 1.
		This bit is always read/write accessible. MPEN is cleared to 0 by H_RESET or S_RESET and is not affected by setting the STOP bit.			This bit is always read/write accessible. MPMODE is cleared to 0 by H_RESET or S_RESET and is not affected by setting the STOP bit.
		This bit is always read/write accessible. MPMODE is cleared to 0 by H_RESET or S_RESET and is not affected by setting the STOP bit.	1	MPMODE	The Am79C978A controller will enter the Magic Packet mode when MPMODE is set to 1 and either PG is asserted or MPEN is set to 1.
4	MPINT	Magic Packet Interrupt. Magic Packet Interrupt is set by the Am79C978A controller when the device is in Magic Packet mode and the Am79C978A controller receives a Magic Packet frame. When MPINT is set to 1, INTA is asserted if IENA (CSR0, bit 6) and the enable bit MPINTE are set to 1.	0	SPND	Suspend. Setting SPND to 1 will cause the Am79C978A controller to start requesting entrance into suspend mode. The host must poll SPND until it reads back 1 to determine that the Am79C978A controller has entered the suspend mode. Setting SPND to 0 will get the Am79C978A controller out of suspend mode. SPND can only be set to 1 if STOP (CSR0, bit 2) is set to 0. H_RESET, S_RESET, or setting the STOP bit will get the Am79C978A controller out of suspend mode.
		This bit is always read/write accessible. MPINT is cleared by the host by writing a 1. Writing a 0 has no affect. MPINT is cleared by H_RESET, S_RESET, or by setting the STOP bit.			Requesting entrance into the suspend mode by the host depends on the setting of the FASTSPNDE bit (CSR7, bit 15). Refer to the bit description of the FASTSPNDE bit and the Suspend section in <i>Detailed Functions, Buffer Management Unit</i> for details.
3	MPINTE	Magic Packet Interrupt Enable. If MPINTE is set to 1, the MPINT bit will be able to set the INTR bit.			In suspend mode, all of the CSR and BCR registers are accessi-
		This bit is always read/write accessible. MPINT is cleared to 0			

ble. As long as the Am79C978A controller is not reset while in suspend mode (by H_RESET, S_RESET, or by setting the STOP bit), no re-initialization of the device is required after the device comes out of suspend mode. The Am79C978A controller will continue at the transmit and receive descriptor ring locations from where it had left, when it entered the suspend mode.

This bit is always read/write accessible. SPND is cleared by H_RESET, S_RESET, or by setting the STOP bit.

CSR6: RX/TX Descriptor Table Length

Bit	Name	Description
31-16	RES	Reserved locations. Written as zeros and read as undefined.
15-12	TLEN	Contains a copy of the transmit encoded ring length (TLEN) field read from the initialization block during the Am79C978A controller initialization. This field is written during the Am79C978A initialization routine. Read accessible only when either the STOP or the SPND bit is set. Write operations have no effect and should not be performed. TLEN is only defined after initialization. These bits are unaffected by H_RESET, S_RESET, or STOP.
11-8	RLEN	Contains a copy of the receive encoded ring length (RLEN) read from the initialization block during Am79C978A controller initialization. This field is written during the Am79C978A initialization routine. Read accessible only when either the STOP or the SPND bit is set. Write operations have no effect and should not be performed. RLEN is only defined after initialization. These bits are unaffected by H_RESET, S_RESET, or STOP.

7-0 RES Reserved locations. Read as 0s. Write operations are ignored.

CSR7: Extended Control and Interrupt 2

Certain bits in CSR7 indicate the cause of an interrupt. The register is designed so that these indicator bits are cleared by writing ones to those bit locations. This means that the software can read CSR7 and write back the value just read to clear the interrupt condition.

Bit	Name	Description
31-16	RES	Reserved locations. Written as zeros and read as undefined.
15	FASTSPNDE	Fast Suspend Enable. When FASTSPNDE is set to 1, the Am79C978A controller performs a fast suspend whenever the SPND bit is set. When a fast suspend is requested, the Am79C978A controller performs a quick entry into the suspend mode. At the time the SPND bit is set, the Am79C978A controller will complete the DMA process of any transmit and/or receive packet that had already begun DMA activity. In addition, any transmit packet that had started transmission will be fully transmitted, and any receive packet that had begun reception will be fully received. However, no additional packets will be transmitted or received and no additional transmit or receive DMA activity will begin. Hence, the Am79C978A controller may enter the suspend mode with transmit and/or receive packets still in the FIFOs or the SRAM. When FASTSPNDE is 0 and the SPND bit is set, the Am79C978A controller may take longer before entering the suspend mode. At the time the SPND bit is set, the Am79C978A controller will complete the DMA process of a transmit packet if it had already begun, and the Am79C978A controller will completely receive a receive packet if it had already begun. Additionally, all transmit packets stored in the transmit FIFOs and the transmit buffer area in the

		SRAM (if one is enabled) will be transmitted and all receive packets stored in the receive FIFOs, and the receive buffer area in the SRAM (if one is enabled) will be transferred into system memory. Since the FIFO and SRAM contents are flushed, it may take much longer before the Am79C978A controller enters the suspend mode. The amount of time that it takes depends on many factors including the size of the SRAM, bus latency, and network traffic level.	12	RXD POLL	Receive Disable Polling. If RXD POLL is set, the Buffer Management Unit will disable receive polling. Likewise, if RXD POLL is cleared, automatic receive polling is enabled. If RXD POLL is set, RDMD bit in CSR7 must be set in order to initiate a manual poll of a receive descriptor. Receive Descriptor Polling will not take place if RXON is reset.
		When a write to CSR5 is performed with bit 0 (SPND) set to 1, the value that is simultaneously written to FASTSPNDE is used to determine which approach is used to enter suspend mode.			This bit is always read/write accessible. RXD POLL is cleared by H_RESET. RXD POLL is unaffected by S_RESET or by setting the STOP bit.
		This bit is always read/write accessible. FASTSPNDE is cleared by H_RESET, S_RESET, or by setting the STOP bit.	11	STINT	Software Timer Interrupt. The Software Timer interrupt is set by the Am79C978A controller when the Software Timer counts down to 0. The Software Timer will immediately load the STVAL (BCR 31, bits 5-0) into the Software Timer and begin counting down.
14	RES	Reserved location.			When STINT is set to 1, \overline{INTA} is asserted if the enable bit STINTE is set to 1.
13	RDMD	Receive Demand, when set, causes the Buffer Management Unit to access the Receive Descriptor Ring without waiting for the receive poll-time counter to elapse. If RXON is not enabled, RDMD has no meaning and no receive Descriptor Ring access will occur.			This bit is always read/write accessible. STINT is cleared by the host by writing a 1. Writing a 0 has no effect. STINT is cleared by H_RESET and is not affected by S_RESET or setting the STOP bit.
		RDMD is required to be set if the RXD POLL bit in CSR7 is set. Setting RDMD while RXD POLL = 0 merely hastens the Am79C978A controller's response to a receive Descriptor Ring Entry.	10	STINTE	Software Timer Interrupt Enable. If STINTE is set, the STINT bit will be able to set the INTR bit.
		This bit is always read/write accessible. RDMD is set by writing a 1. Writing a 0 has no effect. RDMD will be cleared by the Buffer Management Unit when it fetches a receive Descriptor. RDMD is cleared by H_RESET. RDMD is unaffected by S_RESET or by setting the STOP bit.	9	MREINT	PHY Management Read Error Interrupt. The PHY Read Error interrupt is set by the Am79C978A controller to indicate that the currently read register from the PHY is invalid, the contents of BCR34 are incorrect, and the operation should be performed again. The indication of an incorrect read comes from the internal PHY.

		When MREINT is set to 1, $\overline{\text{INTA}}$ is asserted if the enable bit MREINTE is set to 1.	5	MCCINT	PHY Management Command Complete Interrupt. The PHY Management Command Complete Interrupt is set by the Am79C978A controller when a read or write operation to the internal PHY Data Port (BCR34) is complete.
8	MREINTE	PHY Management Read Error Interrupt Enable. If MREINTE is set, the MREINT bit will be able to set the INTR bit. This bit is always read/write accessible. MREINTE is set to 0 by H_RESET and is not affected by S_RESET or setting the STOP bit.			When MCCINT is set to 1, $\overline{\text{INTA}}$ is asserted if the enable bit MCCINTE is set to 1. This bit is always read/write accessible. MCCINT is cleared by the host by writing a 1. Writing a 0 has no effect. MCCINT is cleared by H_RESET and is not affected by S_RESET or setting the STOP bit.
7	MAPINT	PHY Management Auto-Poll Interrupt. The PHY Auto-Poll interrupt is set by the Am79C978A controller to indicate that the currently read status does not match the stored previous status indicating a change in state for the internal PHY. A change in the Auto-Poll Access Method (BCR32, Bit 11) will reset the shadow register and will not cause an interrupt on the first access from the Auto-Poll section. Subsequent accesses will generate an interrupt if the shadow register and the read register produce differences. When MAPINT is set to 1, $\overline{\text{INTA}}$ is asserted if the enable bit MAPINTE is set to 1. This bit is always read/write accessible. MAPINT is cleared by the host by writing a 1. Writing a 0 has no effect. MAPINT is cleared by H_RESET and is not affected by S_RESET or setting the STOP bit.	4	MCCINTE	PHY Management Command Complete Interrupt Enable. If MCCINTE is set to 1, the MCCINT bit will be able to set the INTR bit when the host reads or writes to the internal PHY Data Port (BCR34) only. Internal PHY Management Commands will not generate an interrupt. For instance Auto-Poll state machine generated management frames will not generate an interrupt upon completion unless there is a compare error which gets reported through the MAPINT (CSR7, bit 6) interrupt or the MCCIINTE is set to 1. This bit is always read/write accessible. MCCINTE is set to 0 by H_RESET and is not affected by S_RESET or setting the STOP bit.
6	MAPINTE	PHY Auto-Poll Interrupt Enable. If MAPINTE is set, the MAPINT bit will be able to set the INTR bit. This bit is always read/write accessible. MAPINTE is set to 0 by H_RESET and is not affected by S_RESET or setting the STOP bit.	3	MCCIINT	PHY Management Command Complete Internal Interrupt. The PHY Management Command Complete Interrupt is set by the Am79C978A controller when a read or write operation on the internal PHY management port is complete from an internal operation. Examples of internal operations are Auto-Poll or PHY Management Port generated management frames. These are normally hidden to the host.

When MCCIINT is set to 1, \overline{INTA} is asserted if the enable bit MCCINTE is set to 1.

This bit is always read/write accessible. MCCIINT is cleared by the host by writing a 1. Writing a 0 has no effect. MCCIINT is cleared by H_RESET and is not affected by S_RESET or setting the STOP bit.

- 2 MCCIINTE PHY Management Command Complete Internal Interrupt Enable. If MCCIINTE is set to 1, the MCCIINT bit will be able to set the INTR bit when the internal state machines generate management frames. For instance, when MCCIINTE is set to 1 and the Auto-Poll state machine generates a management frame, the MCCIINT will set the INTR bit upon completion of the management frame regardless of the comparison outcome.

This bit is always read/write accessible. MCCIINTE is set to 0 by H_RESET and is not affected by S_RESET or setting the STOP bit.

- 1 MIIPDTINT PHY Detect Transition Interrupt. The PHY Detect Transition Interrupt is set by the Am79C978A controller whenever the MIIPD bit (BCR32, bit 14) transitions from 0 to 1 or vice versa.

This bit is always read/write accessible. MIIPDTINT is cleared by the host by writing a 1. Writing a 0 has no effect. MIIPDTINT is cleared by H_RESET and is not affected by S_RESET or setting the STOP bit.

- 0 MIIPDTINT PHY Detect Transition Interrupt Enable. If MIIPDTINTE is set to 1, the MIIPDTINT bit will be able to set the INTR bit.

This bit is always read/write accessible. MIIPDTINTE is set to 0 by H_RESET and is not affected by S_RESET or setting the STOP bit.

CSR8: Logical Address Filter 0

Bit	Name	Description
31-16	RES	Reserved locations. Written as zeros and read as undefined.
15-0	LADRF[15:0]	Logical Address Filter, LADRF-[15:0]. The content of this register is undefined until loaded from the initialization block after the INIT bit in CSR0 has been set or a direct register write has been performed on this register.

These bits are read/write accessible only when either the STOP or the SPND bit is set. These bits are unaffected by H_RESET, S_RESET, or STOP.

CSR9: Logical Address Filter 1

Bit	Name	Description
31-16	RES	Reserved locations. Written as zeros and read as undefined.
15-0	LADRF[31:16]	Logical Address Filter, LADRF-[31:16]. The content of this register is undefined until loaded from the initialization block after the INIT bit in CSR0 has been set or a direct register write has been performed on this register.

These bits are read/write accessible only when either the STOP or the SPND bit is set. These bits are unaffected by H_RESET, S_RESET, or STOP.

CSR10: Logical Address Filter 2

Bit	Name	Description
31-16	RES	Reserved locations. Written as zeros and read as undefined.
15-0	LADRF[47:32]	Logical Address Filter, LADRF[47:32]. The content of this register is undefined until loaded from the initialization block after the INIT bit in CSR0 has been set or a direct register write has been performed on this register.

These bits are read/write accessible only when either the STOP or the SPND bit is set. These bits are unaffected by H_RESET, S_RESET, or STOP.

CSR11: Logical Address Filter 3

Bit	Name	Description
31-16	RES	Reserved locations. Written as zeros and read as undefined.
15-0	LADRF[63:48]	Logical Address Filter, LADRF[63:48]. The content of this register is undefined until loaded from the initialization block after the INIT bit in CSR0 has been set or a direct register write has been performed on this register.

These bits are read/write accessible only when either the STOP or the SPND bit is set. These bits are unaffected by H_RESET, S_RESET, or STOP.

CSR12: Physical Address Register 0

Note: Bits 15-0 in this register are programmable through the EEPROM.

Bit	Name	Description
31-16	RES	Reserved locations. Written as zeros and read as undefined.
15-0	PADR[15:0]	Physical Address Register, PADR[15:0]. The contents of this register are loaded from the EEPROM after H_RESET or by an EEPROM read command (PRGAD, BCR19, bit 14). If the EEPROM is not present, the contents of this register are undefined.

This register can also be loaded from the initialization block after the INIT bit in CSR0 has been set or a direct register write has been performed on this register.

These bits are read/write accessible only when either the STOP or the SPND bit is set. These bits

are unaffected by H_RESET, S_RESET, or STOP.

CSR13: Physical Address Register 1

Note: Bits 15-0 in this register are programmable through the EEPROM.

Bit	Name	Description
31-16	RES	Reserved locations. Written as zeros and read as undefined.
15-0	PADR[31:16]	Physical Address Register, PADR[31:16]. The contents of this register are loaded from the EEPROM after H_RESET or by an EEPROM read command (PRGAD, BCR19, bit 14). If the EEPROM is not present, the contents of this register are undefined.

This register can also be loaded from the initialization block after the INIT bit in CSR0 has been set or a direct register write has been performed on this register.

These bits are read/write accessible only when either the STOP or the SPND bit is set. These bits are unaffected by H_RESET, S_RESET, or STOP.

CSR14: Physical Address Register 2

Note: Bits 15-0 in this register are programmable through the EEPROM.

Bit	Name	Description
31-16	RES	Reserved locations. Written as zeros and read as undefined.
15-0	PADR[47:32]	Physical Address Register, PADR[47:32]. The contents of this register are loaded from the EEPROM after H_RESET or by an EEPROM read command (PRGAD, BCR19, bit 14). If the EEPROM is not present, the contents of this register are undefined.

This register can also be loaded from the initialization block after the INIT bit in CSR0 has been set or a direct register write has been performed on this register.

These bits are read/write accessible only when either the STOP or the SPND bit is set. These bits are unaffected by H_RESET, S_RESET, or STOP.

network medium. The only legal values for this field is 11.

CSR15: Mode

This register's fields are loaded during the Am79C978A controller initialization routine with the corresponding Initialization Block values, or when a direct register write has been performed on this register.

This bit is read/write accessible only when either the STOP or the SPND bit is set. Cleared by H_RESET or S_RESET and is unaffected by STOP.

Bit	Name	Description
-----	------	-------------

31-16	RES	Reserved locations. Written as zeros and read as undefined.
-------	-----	---

6	INTL	Internal Loopback. See the description of LOOP (CSR15, bit 2).
---	------	--

15	PROM	Promiscuous Mode. When PROM = 1, all incoming receive frames are accepted.
----	------	--

5	DRTY	Disable Retry. When DRTY is set to 1, the Am79C978A controller will attempt only one transmission. In this mode, the device will not protect the first 64 bytes of frame data in the Transmit FIFO from being overwritten, because automatic retransmission will not be necessary. When DRTY is set to 0, the Am79C978A controller will attempt 16 transmissions before signaling a retry error.
---	------	--

This bit is read/write accessible only when either the STOP or the SPND bit is set.

14	DRCVBC	Disable Receive Broadcast. When set, disables the Am79C978A controller from receiving broadcast messages. Used for protocols that do not support broadcast addressing, except as a function of multicast. DRCVBC is cleared by activation of H_RESET or S_RESET (broadcast messages will be received) and is unaffected by STOP.
----	--------	--

4	FCOLL	Force Collision. This bit allows the collision logic to be tested. The Am79C978A controller must be in internal loopback for FCOLL to be valid. If FCOLL = 1, a collision will be forced during loopback transmission attempts, which will result in a Retry Error. If FCOLL = 0, the Force Collision logic will be disabled. FCOLL is defined after the initialization block is read.
---	-------	--

This bit is read/write accessible only when either the STOP or the SPND bit is set.

13	DRCVPA	Disable Receive Physical Address. When set, the physical address detection (Station or node ID) of the Am79C978A controller will be disabled. Frames addressed to the nodes individual physical address will not be recognized.
----	--------	---

This bit is read/write accessible only when either the STOP or the SPND bit is set.

This bit is read/write accessible only when either the STOP or the SPND bit is set.

12-9	RES	Reserved locations. Written as zeros and read as undefined.
------	-----	---

3	DXMTFCS	Disable Transmit CRC (FCS). When DXMTFCS is set to 0, the transmitter will generate and append an FCS to the transmitted frame. When DXMTFCS is set to 1, no FCS is generated or sent with the transmitted frame. DXMTFCS is overridden when ADD_FCS and ENP bits are set in TMD1.
---	---------	--

8-7	PORTSEL[1:0]	Port Select bits allow for software controlled selection of the
-----	--------------	---

When the APAD_XMT bit (CSR4, bit11) is set to 1, the setting of DXMTFCS has no effect.

If DXMTFCS is set and ADD_FCS is clear for a particular frame, no FCS will be generated. If ADD_FCS is set for a particular frame, the state of DXMTFCS is ignored and a FCS will be appended on that frame by the transmit circuitry. See also the ADD_FCS bit in TMD1.

This bit was called DTCR in the LANCE (Am7990) device.

This bit is read/write accessible only when either the STOP or the SPND bit is set.

2 LOOP Loopback Enable allows the Am79C978A controller to operate in full-duplex mode for test purposes. The setting of the full-duplex control bits in BCR9 have no effect when the device operates in loopback mode. When LOOP = 1, loopback is enabled. In combination with INTL and MIILP, various loopback modes are defined as follows in Table 31.

Table 31. Loopback Configuration

LOOP	INTL	MIILP	Function
0	0	0	Normal Operation
0	0	1	Internal Loop
1	0	0	External Loop

Refer to *Loopback Operation* section for more details.

This bit is read/write accessible only when either the STOP or the SPND bit is set. LOOP is cleared by H_RESET or S_RESET and is unaffected by STOP.

1 DTX Disable Transmit results in Am79C978A controller not accessing the Transmit Descriptor Ring and, therefore, no transmissions are attempted. DTX = 0, will set TXON bit (CSR0 bit 4) if STRT (CSR0 bit 1) is asserted.

This bit is read/write accessible only when either the STOP or the SPND bit is set.

0 DRX Disable Receiver results in the Am79C978A controller not accessing the Receive Descriptor Ring and, therefore, all receive frame data are ignored. DRX = 0 will set RXON bit (CSR0 bit 5) if STRT (CSR0 bit 1) is asserted.

This bit is read/write accessible only when either the STOP or the SPND bit is set.

CSR16: Initialization Block Address Lower

Bit	Name	Description
31-16	RES	Reserved locations. Written as zeros and read as undefined.
15-0	IADRL	This register is an alias of CSR1. These bits are read/write accessible only when either the STOP or the SPND bit is set.

CSR17: Initialization Block Address Upper

Bit	Name	Description
31-16	RES	Reserved locations. Written as zeros and read as undefined.
15-0	IADRH	This register is an alias of CSR2. These bits are read/write accessible only when either the STOP or the SPND bit is set.

CSR18: Current Receive Buffer Address Lower

Bit	Name	Description
31-16	RES	Reserved locations. Written as zeros and read as undefined.
15-0	CRBAL	Contains the lower 16 bits of the current receive buffer address at which the Am79C978A controller will store incoming frame data. These bits are read/write accessible only when either the STOP or the SPND bit is set. These bits are unaffected by H_RESET, S_RESET, or STOP.

CSR19: Current Receive Buffer Address Upper

Bit	Name	Description
31-16	RES	Reserved locations. Written as zeros and read as undefined.
15-0	CRBAU	Contains the upper 16 bits of the current receive buffer address at which the Am79C978A controller will store incoming frame data. These bits are read/write accessible only when either the STOP or the SPND bit is set. These bits are unaffected by H_RESET, S_RESET, or STOP.

CSR20: Current Transmit Buffer Address Lower

Bit	Name	Description
31-16	RES	Reserved locations. Written as zeros and read as undefined.
15-0	CXBAL	Contains the lower 16 bits of the current transmit buffer address from which the Am79C978A controller is transmitting. These bits are read/write accessible only when either the STOP or the SPND bit is set. These bits are unaffected by H_RESET, S_RESET, or STOP.

CSR21: Current Transmit Buffer Address Upper

Bit	Name	Description
31-16	RES	Reserved locations. Written as zeros and read as undefined.
15-0	CXBAU	Contains the upper 16 bits of the current transmit buffer address from which the Am79C978A controller is transmitting. These bits are read/write accessible only when either the STOP or the SPND bit is set. These bits are unaffected by H_RESET, S_RESET, or STOP.

CSR22: Next Receive Buffer Address Lower

Bit	Name	Description
31-16	RES	Reserved locations. Written as zeros and read as undefined.

15-0	NRBAL	Contains the lower 16 bits of the next receive buffer address to which the Am79C978A controller will store incoming frame data. These bits are read/write accessible only when either the STOP or the SPND bit is set. These bits are unaffected by H_RESET, S_RESET, or STOP.
------	-------	---

CSR23: Next Receive Buffer Address Upper

Bit	Name	Description
31-16	RES	Reserved locations. Written as zeros and read as undefined.
15-0	NRBAU	Contains the upper 16 bits of the next receive buffer address to which the Am79C978A controller will store incoming frame data. These bits are read/write accessible only when either the STOP or the SPND bit is set. These bits are unaffected by H_RESET, S_RESET, or STOP.

CSR24: Base Address of Receive Ring Lower

Bit	Name	Description
31-16	RES	Reserved locations. Written as zeros and read as undefined.
15-0	BADRL	Contains the lower 16 bits of the base address of the Receive Ring. These bits are read/write accessible only when either the STOP or the SPND bit is set. These bits are unaffected by H_RESET, S_RESET, or STOP.

CSR25: Base Address of Receive Ring Upper

Bit	Name	Description
31-16	RES	Reserved locations. Written as zeros and read as undefined.
15-0	BADRU	Contains the upper 16 bits of the base address of the Receive Ring. These bits are read/write accessible only when either the STOP or the SPND bit is set. These bits

are unaffected by H_RESET, S_RESET, or STOP.

CSR26: Next Receive Descriptor Address Lower

Bit	Name	Description
31-16	RES	Reserved locations. Written as zeros and read as undefined.
15-0	NRDAL	Contains the lower 16 bits of the next receive descriptor address pointer. These bits are read/write accessible only when either the STOP or the SPND bit is set. These bits are unaffected by H_RESET, S_RESET, or STOP.

CSR27: Next Receive Descriptor Address Upper

Bit	Name	Description
31-16	RES	Reserved locations. Written as zeros and read as undefined.
15-0	NRDAU	Contains the upper 16 bits of the next receive descriptor address pointer. These bits are read/write accessible only when either the STOP or the SPND bit is set. These bits are unaffected by H_RESET, S_RESET, or STOP.

CSR28: Current Receive Descriptor Address Lower

Bit	Name	Description
31-16	RES	Reserved locations. Written as zeros and read as undefined.
15-0	CRDAL	Contains the lower 16 bits of the current receive descriptor address pointer. These bits are read/write accessible only when either the STOP or the SPND bit is set. These bits are unaffected by H_RESET, S_RESET, or STOP.

CSR29: Current Receive Descriptor Address Upper

Bit	Name	Description
31-16	RES	Reserved locations. Written as zeros and read as undefined.
15-0	CRDAU	Contains the upper 16 bits of the current receive descriptor address pointer. These bits are read/write accessible only when either the STOP or the SPND bit is set. These bits are unaffected by H_RESET, S_RESET, or STOP.

CSR30: Base Address of Transmit Ring Lower

Bit	Name	Description
31-16	RES	Reserved locations. Written as zeros and read as undefined.
15-0	BADXL	Contains the lower 16 bits of the base address of the Transmit Ring. These bits are read/write accessible only when either the STOP or the SPND bit is set. These bits are unaffected by H_RESET, S_RESET, or STOP.

CSR31: Base Address of Transmit Ring Upper

Bit	Name	Description
31-16	RES	Reserved locations. Written as zeros and read as undefined.
15-0	BADXU	Contains the upper 16 bits of the base address of the Transmit Ring. These bits are read/write accessible only when either the STOP or the SPND bit is set. These bits are unaffected by H_RESET, S_RESET, or STOP.

CSR32: Next Transmit Descriptor Address Lower

Bit	Name	Description
31-16	RES	Reserved locations. Written as zeros and read as undefined.
15-0	NXDAL	Contains the lower 16 bits of the next transmit descriptor address pointer.

These bits are read/write accessible only when either the STOP or the SPND bit is set. These bits are unaffected by H_RESET, S_RESET, or STOP.

CSR33: Next Transmit Descriptor Address Upper

Bit	Name	Description
31-16	RES	Reserved locations. Written as zeros and read as undefined.
15-0	NXDAU	Contains the upper 16 bits of the next transmit descriptor address pointer. These bits are read/write accessible only when either the STOP or the SPND bit is set. These bits are unaffected by H_RESET, S_RESET, or STOP.

CSR34: Current Transmit Descriptor Address Lower

Bit	Name	Description
31-16	RES	Reserved locations. Written as zeros and read as undefined.
15-0	CXDAL	Contains the lower 16 bits of the current transmit descriptor address pointer. These bits are read/write accessible only when either the STOP or the SPND bit is set. These bits are unaffected by H_RESET, S_RESET, or STOP.

CSR35: Current Transmit Descriptor Address Upper

Bit	Name	Description
31-16	RES	Reserved locations. Written as zeros and read as undefined.
15-0	CXDAU	Contains the upper 16 bits of the current transmit descriptor address pointer. These bits are read/write accessible only when either the STOP or the SPND bit is set. These bits are unaffected by H_RESET, S_RESET, or STOP.

CSR36: Next Next Receive Descriptor Address Lower

Bit	Name	Description
31-16	RES	Reserved locations. Written as zeros and read as undefined.
15-0	NNRDAL	Contains the lower 16 bits of the next next receive descriptor address pointer. These bits are read/write accessible only when either the STOP or the SPND bit is set. These bits are unaffected by H_RESET, S_RESET, or STOP.

CSR37: Next Next Receive Descriptor Address Upper

Bit	Name	Description
31-16	RES	Reserved locations. Written as zeros and read as undefined.
15-0	NNRDAU	Contains the upper 16 bits of the next next receive descriptor address pointer. These bits are read/write accessible only when either the STOP or the SPND bit is set. These bits are unaffected by H_RESET, S_RESET, or STOP.

CSR38: Next Next Transmit Descriptor Address Lower

Bit	Name	Description
31-16	RES	Reserved locations. Written as zeros and read as undefined.
15-0	NNXDAL	Contains the lower 16 bits of the next next transmit descriptor address pointer. These bits are read/write accessible only when either the STOP or the SPND bit is set. These bits are unaffected by H_RESET, S_RESET, or STOP.

CSR39: Next Next Transmit Descriptor Address**Upper**

Bit	Name	Description
31-16	RES	Reserved locations. Written as zeros and read as undefined.
15-0	NNXDAU	Contains the upper 16 bits of the next next transmit descriptor address pointer. These bits are read/write accessible only when either the STOP or the SPND bit is set. These bits are unaffected by H_RESET, S_RESET, or STOP.

CSR40: Current Receive Byte Count

Bit	Name	Description
31-16	RES	Reserved locations. Written as zeros and read as undefined.
15-12	RES	Reserved locations. Read and written as zeros.
11-0	CRBC	Current Receive Byte Count. This field is a copy of the BCNT field of RMD1 of the current receive descriptor. These bits are read/write accessible only when either the STOP or the SPND bit is set. These bits are unaffected by H_RESET, S_RESET, or STOP.

CSR41: Current Receive Status

Bit	Name	Description
31-16	RES	Reserved locations. Written as zeros and read as undefined.
15-0	CRST	Current Receive Status. This field is a copy of bits 31-16 of RMD1 of the current receive descriptor. These bits are read/write accessible only when either the STOP or the SPND bit is set. These bits are unaffected by H_RESET, S_RESET, or STOP.

CSR42: Current Transmit Byte Count

Bit	Name	Description
31-16	RES	Reserved locations. Written as zeros and read as undefined.
15-12	RES	Reserved locations. Read and written as zeros.
11-0	CXBC	Current Transmit Byte Count. This field is a copy of the BCNT field of TMD1 of the current transmit descriptor. These bits are read/write accessible only when either the STOP or the SPND bit is set. These bits are unaffected by H_RESET, S_RESET, or STOP.

CSR43: Current Transmit Status

Bit	Name	Description
31-16	RES	Reserved locations. Written as zeros and read as undefined.
15-0	CXST	Current Transmit Status. This field is a copy of bits 31-16 of TMD1 of the current transmit descriptor. These bits are read/write accessible only when either the STOP or the SPND bit is set. These bits are unaffected by H_RESET, S_RESET, or STOP.

CSR44: Next Receive Byte Count

Bit	Name	Description
31-16	RES	Reserved locations. Written as zeros and read as undefined.
15-12	RES	Reserved locations. Read and written as zeros.
11-0	NRBC	Next Receive Byte Count. This field is a copy of the BCNT field of RMD1 of the next receive descriptor. These bits are read/write accessible only when either the STOP or the SPND bit is set. These bits are unaffected by H_RESET, S_RESET, or STOP.

CSR45: Next Receive Status

Bit	Name	Description
31-16	RES	Reserved locations. Written as zeros and read as undefined.
15-0	NRST	Next Receive Status. This field is a copy of bits 31-16 of RMD1 of the next receive descriptor. These bits are read/write accessible only when either the STOP or the SPND bit is set. These bits are unaffected by H_RESET, S_RESET, or STOP.

CSR46: Transmit Poll Time Counter

Bit	Name	Description
31-16	RES	Reserved locations. Written as zeros and read as undefined.
15-0	TXPOLL	Transmit Poll Time Counter. This counter is incremented by the Am79C978A controller microcode and is used to trigger the transmit descriptor ring polling operation of the Am79C978A controller. These bits are read/write accessible only when either the STOP or the SPND bit is set. These bits are unaffected by H_RESET, S_RESET, or STOP.

CSR47: Transmit Polling Interval

Bit	Name	Description
31-16	RES	Reserved locations. Written as zeros and read as undefined.
15-0	TXPOLLINT	Transmit Polling Interval. This register contains the time that the Am79C978A controller will wait between successive polling operations. The TXPOLLINT value is expressed as the two's complement of the desired interval, where each bit of TXPOLLINT represents 1 clock period of time. TXPOLLINT[3:0] are ignored. (TXPOLLINT[16] is implied to be a one, so TXPOLLINT[15] is significant and does not represent the sign of the two's complement TXPOLLINT value.)

The default value of this register is 0000h. This corresponds to a polling interval of 65,536 clock periods (1.966 ms when CLK = 33 MHz). The TXPOLLINT value of 0000h is created during the microcode initialization routine and, therefore, might not be seen when reading CSR47 after H_RESET or S_RESET.

If the user desires to program a value for POLLINT other than the default, then the correct procedure is to first set INIT only in CSR0. Then, when the initialization sequence is complete, the user must set STOP (CSR0, bit 2). Then the user may write to CSR47 and then set STRT in CSR0. In this way, the default value of 0000h in CSR47 will be overwritten with the desired user value.

If the user does *not* use the standard initialization procedure (standard implies use of an initialization block in memory and setting the INIT bit of CSR0), but instead chooses to write directly to each of the registers that are involved in the INIT operation, then it is imperative that the user also writes all zeros to CSR47 as part of the alternative initialization sequence.

These bits are read/write accessible only when either the STOP or the SPND bit is set. These bits are unaffected by H_RESET, S_RESET, or STOP.

CSR48: Receive Poll Time Counter

Bit	Name	Description
31-16	RES	Reserved locations. Written as zeros and read as undefined.
15-0	RXPOLL	Receive Poll Time Counter. This counter is incremented by the Am79C978A controller microcode and is used to trigger the receive descriptor ring polling operation of the Am79C978A controller.

These bits are read/write accessible only when either the STOP or the SPND bit is set. These bits are unaffected by H_RESET, S_RESET, or STOP.

CSR49: Receive Polling Interval

Bit	Name	Description
31-16	RES	Reserved locations. Written as zeros and read as undefined.
15-0	RXPOLLINT	<p>Receive Polling Interval. This register contains the time that the Am79C978A controller will wait between successive polling operations. The RXPOLLINT value is expressed as the two's complement of the desired interval, where each bit of RXPOLLINT represents approximately one clock time period. RXPOLLINT[3:0] are ignored. (RXPOLLINT[16] is implied to be a 1, so RXPOLLINT[15] is significant and does not represent the sign of the two's complement RXPOLLINT value.)</p> <p>The default value of this register is 0000h. This corresponds to a polling interval of 65,536 clock periods (1.966 ms when CLK = 33 MHz). The RXPOLLINT value of 0000h is created during the microcode initialization routine and, therefore, might not be seen when reading CSR49 after H_RESET or S_RESET.</p> <p>If the user desires to program a value for RXPOLLINT other than the default, then the correct procedure is to first set INIT only in CSR0. Then, when the initialization sequence is complete, the user must set STOP (CSR0, bit 2). Then the user may write to CSR49 and set STRT in CSR0. In this way, the default value of 0000h in CSR47 will be overwritten with the desired user value.</p> <p>If the user does <i>not</i> use the standard initialization procedure (standard implies use of an initialization block in memory and setting the INIT bit of CSR0), but instead chooses to write directly to each of</p>

the registers that are involved in the INIT operation, it is imperative that the user also writes all zeros to CSR49 as part of the alternative initialization sequence.

These bits are read/write accessible only when either the STOP or the SPND bit is set. These bits are unaffected by H_RESET, S_RESET, or STOP.

CSR58: Software Style

This register is an alias of the location BCR20. Accesses to and from this register are equivalent to accesses to BCR20.

Bit	Name	Description
31-11	RES	Reserved locations. Written as zeros and read as undefined.
10	APERREN	<p>Advanced Parity Error Handling Enable. When APERREN is set to 1, the BPE bits (RMD1 and TMD1, bit 23) start having a meaning. BPE will be set in the descriptor associated with the buffer that was accessed when a data parity error occurred. Note that since the advanced parity error handling uses an additional bit in the descriptor, SWSTYLE (bits 7-0 of this register) must be set to 2 or 3 to program the Am79C978A controller to use 32-bit software structures.</p> <p>APERREN does not affect the reporting of address parity errors or data parity errors that occur when the Am79C978A controller is the target of the transfer.</p> <p>Read anytime, write accessible only when either the STOP or the SPND bit is set. APERREN is cleared by H_RESET and is not affected by S_RESET or STOP.</p>
9	RES	Reserved location. Written as zero and read as undefined.
8	SSIZE32	Software Size 32 bits. When set, this bit indicates that the Am79C978A controller utilizes 32-bit software structures for the initialization block and the transmit and receive descriptor en-

tries. When cleared, this bit indicates that the Am79C978A controller utilizes 16-bit software structures for the initialization block and the transmit and receive descriptor entries. In this mode, the Am79C978A controller is backwards compatible with the Am7990 LANCE and Am79C960 PCnet-ISA controllers.

The value of SSIZE32 is determined by the Am79C978A controller according to the setting of the Software Style (SWSTYLE, bits 7-0 of this register).

Read accessible always. SSIZE32 is read only; write operations will be ignored. SSIZE32 will be cleared after H_RESET (since SWSTYLE defaults to 0) and is not affected by S_RESET or STOP.

If SSIZE32 is reset, then bits IADR[31:24] of CSR2 will be used to generate values for the upper 8 bits of the 32-bit address bus during master accesses initiated by the Am79C978A controller. This action is required because the 16-bit software structures specified by the SSIZE32 = 0 setting will yield only 24 bits of address for the Am79C978A controller bus master accesses.

If SSIZE32 is set, then the software structures that are common to the Am79C978A controller and the host system will supply a full 32 bits for each address pointer that is needed by the Am79C978A controller for performing master accesses.

The value of the SSIZE32 bit has no effect on the drive of the upper 8 address bits. The upper 8 address pins are always driven, regardless of the state of the SSIZE32 bit.

Note that the setting of the SSIZE32 bit has no effect on the defined width for I/O resources. I/O resource width is determined by the state of the DWIO bit (BCR18, bit 7).

7-0 SWSTYLE

Software Style register. The value in this register determines the style of register and memory resources that shall be used by the Am79C978A controller. The Software Style selection will affect the interpretation of a few bits within the CSR space, the order of the descriptor entries and the width of the descriptors and initialization block entries.

All Am79C978A controller CSR bits and BCR bits and all descriptor, buffer, and initialization block entries not cited in Table 32 are unaffected by the Software Style selection and are, therefore, always fully functional as specified in the CSR and BCR sections.

These bits are read/write accessible only when either the STOP or the SPND bit is set. The SWSTYLE register will contain the value 00h following H_RESET and will be unaffected by S_RESET or STOP.

Table 32. Software Styles

SWSTYLE [7:0]	Style Name	SSIZE32	Initialization Block Entries	Descriptor Ring Entries
00h	LANCE/PCnet-ISA controller	0	16-bit software structures, non-burst or burst access	16-bit software structures, non-burst access only
01h	RES	1	RES	RES
02h	PCnet-PCI controller	1	32-bit software structures, non-burst or burst access	32-bit software structures, non-burst access only
03h	PCnet-PCI controller	1	32-bit software structures, non-burst or burst access	32-bit software structures, non-burst or burst access
All Other	RES	Undefined	Undefined	Undefined

CSR60: Previous THd3nsmit Descriptor Address Lower

Bit	Name	Description
31-16	RES	Reserved locations. Written as zeros and read as undefined.
15-0	PXDAL	Contains the lower 16 bits of the previous transmit descriptor address pointer. The Am79C978A controller has the capability to stack multiple transmit frames. These bits are read/write accessible only when either the STOP or the SPND bit is set. These bits are unaffected by H_RESET, S_RESET, or STOP.

CSR61: Previous Transmit Descriptor Address Upper

Bit	Name	Description
31-16	RES	Reserved locations. Written as zeros and read as undefined.
15-0	PXDAU	Contains the upper 16 bits of the previous transmit descriptor address pointer. The Am79C978A controller has the capability to stack multiple transmit frames. These bits are read/write accessible only when either the STOP or the SPND bit is set. These bits are unaffected by H_RESET, S_RESET, or STOP.

CSR62: Previous Transmit Byte Count

Bit	Name	Description
31-16	RES	Reserved locations. Written as zeros and read as undefined.
15-12	RES	Reserved locations.
11-0	PXBC	Previous Transmit Byte Count. This field is a copy of the BCNT field of TMD1 of the previous transmit descriptor. These bits are read/write accessible only when either the STOP or the SPND bit is set. These bits are unaffected by H_RESET, S_RESET, or STOP.

CSR63: Previous Transmit Status

Bit	Name	Description
31-16	RES	Reserved locations. Written as zeros and read as undefined.
15-0	PXST	Previous Transmit Status. This field is a copy of bits 31-16 of TMD1 of the previous transmit descriptor. These bits are read/write accessible only when either the STOP or the SPND bit is set. These bits are unaffected by H_RESET, S_RESET, or STOP.

CSR64: Next Transmit Buffer Address Lower

Bit	Name	Description
31-16	RES	Reserved locations. Written as zeros and read as undefined.
15-0	NXBAL	Contains the lower 16 bits of the next transmit buffer address from which the Am79C978A controller will transmit an outgoing frame. These bits are read/write accessible only when either the STOP or the SPND bit is set. These bits are unaffected by H_RESET, S_RESET, or STOP.

CSR65: Next Transmit Buffer Address Upper

Bit	Name	Description
31-16	RES	Reserved locations. Written as zeros and read as undefined.
15-0	NXBAU	Contains the upper 16 bits of the next transmit buffer address from which the Am79C978A controller will transmit an outgoing frame. These bits are read/write accessible only when either the STOP or the SPND bit is set. These bits are unaffected by H_RESET, S_RESET, or STOP.

CSR66: Next Transmit Byte Count

Bit	Name	Description
31-16	RES	Reserved locations. Written as zeros and read as undefined.
15-12	RES	Reserved locations. Read and written as zeros.
11-0	NXBC	Next Transmit Byte Count. This field is a copy of the BCNT field of TMD1 of the next transmit descriptor. These bits are read/write accessible only when either the STOP or the SPND bit is set. These bits are unaffected by H_RESET, S_RESET, or STOP.

CSR67: Next Transmit Status

Bit	Name	Description
31-16	RES	Reserved locations. Written as zeros and read as undefined.
15-0	NXST	Next Transmit Status. This field is a copy of bits 31-16 of TMD1 of the next transmit descriptor. These bits are read/write accessible only when either the STOP or the SPND bit is set. These bits are unaffected by H_RESET, S_RESET, or STOP.
7-0	RES	Reserved locations. Read and written as zeros. Accessible only when either the STOP or the SPND bit is set.

CSR72: Receive Ring Counter

Bit	Name	Description
31-16	RES	Reserved locations. Written as zeros and read as undefined.
15-0	RCVRC	Receive Ring Counter location. Contains a two's complement binary number used to number the current receive descriptor. This counter interprets the value in CSR76 as pointing to the first descriptor. A counter value of zero corresponds to the last descriptor in the ring. These bits are read/write accessible only when either the STOP or the SPND bit is set. These bits are unaffected by H_RESET, S_RESET, or STOP.

CSR74: Transmit Ring Counter

Bit	Name	Description
31-16	RES	Reserved locations. Written as zeros and read as undefined.
15-0	XMTRC	Transmit Ring Counter location. Contains a two's complement binary number used to number the current transmit descriptor. This counter interprets the value in CSR78 as pointing to the first descriptor. A counter value of zero corresponds to the last descriptor in the ring.

These bits are read/write accessible only when either the STOP or the SPND bit is set. These bits are unaffected by H_RESET, S_RESET, or STOP.

are unaffected by H_RESET, S_RESET, or STOP.

CSR76: Receive Ring Length

Bit	Name	Description
31-16	RES	Reserved locations. Written as zeros and read as undefined.
15-0	RCVRL	Receive Ring Length. Contains the two's complement of the receive descriptor ring length. This register is initialized during the Am79C978A controller's initialization routine based on the value in the RLEN field of the initialization block. However, this register can be manually altered. The actual receive ring length is defined by the current value in this register. The ring length can be defined as any value from 1 to 65535.

These bits are read/write accessible only when either the STOP or the SPND bit is set. These bits are unaffected by H_RESET, S_RESET, or STOP.

CSR78: Transmit Ring Length

Bit	Name	Description
31-16	RES	Reserved locations. Written as zeros and read as undefined.
15-0	XMTRL	Transmit Ring Length. Contains the two's complement of the transmit descriptor ring length. This register is initialized during the Am79C978A controller's initialization routine based on the value in the TLEN field of the initialization block. However, this register can be manually altered. The actual transmit ring length is defined by the current value in this register. The ring length can be defined as any value from 1 to 65535.

These bits are read/write accessible only when either the STOP or the SPND bit is set. These bits

CSR80: DMA Transfer Counter and FIFO Threshold Control

Bit	Name	Description
31-16	RES	Reserved locations. Written as zeros and read as undefined.
15-14	RES	Reserved locations. Written as zeros and read as undefined.
13-12	RCVFW[1:0]	Receive FIFO Watermark. RCVFW controls the point at which receive DMA is requested in relation to the number of received bytes in the Receive FIFO. RCVFW specifies the number of bytes which must be present (once the frame has been verified as a non-runt) before receive DMA is requested. Note, however, that if the network interface is operating in half-duplex mode, in order for receive DMA to be performed for a new frame at least 64 bytes must have been received. This effectively avoids having to react to receive frames which are runts or suffer a collision during the slot time (512 bit times). If the Runt Packet Accept feature is enabled or if the network interface is operating in full-duplex mode, receive DMA will be requested as soon as either the RCVFW threshold is reached or a complete valid receive frame is detected (regardless of length). When the FDRPAD (BCR9, bit 2) is set and the Am79C978A controller is in full-duplex mode, in order for receive DMA to be performed for a new frame at least 64 bytes must have been received. This effectively disables the runt packet accept feature in full duplex.

When operating in the NO-SRAM mode (no SRAM enabled), the Bus Receive FIFO and the MAC Receive operate like a single FIFO and the watermark value selected by RCVFW[1:0] sets the number of bytes that must be

present in the FIFO before receive DMA is requested.

When operating with the SRAM, the Bus Receive FIFO, and the MAC Receive FIFO operate independently on the bus side and MAC side of the SRAM, respectively. In this case, the watermark value set by RCVFW[1:0] sets the number of bytes that must be present in the Bus Receive FIFO only. See Table 33.

the data is transmitted, because no collision handling is required in these modes.

Note that when the SRAM is being used, if the NOUFLO bit (BCR18, bit 11) is set to 1, there is the additional restriction that the complete transmit frame must be DMA'd into the Am79C978A controller and reside within a combination of the Bus Transmit FIFO, the SRAM, and the MAC Transmit FIFO.

Table 33. Receive Watermark Programming

RCVFW[1:0]	Bytes Received
00	16
01	64
10	112
11	Reserved

These bits are read/write accessible only when either the STOP or the SPND bit is set. RCVFW[1:0] is set to a value of 01b (64 bytes) after H_RESET or S_RESET and is unaffected by STOP.

When the SRAM is used and SRAM_SIZE > 0, there is a restriction that the number of bytes written is a combination of bytes written into the Bus Transmit FIFO and the MAC Transmit FIFO. The Am79C978A controller supports a mode that will wait until a full packet is available before commencing with the transmission of preamble. This mode is useful in a system where high latencies cannot be avoided. See Table 34.

11-10 XMTSP[1:0] Transmit Start Point. XMTSP controls the point at which preamble transmission attempts to commence in relation to the number of bytes written to the MAC Transmit FIFO for the current transmit frame. When the entire frame is in the MAC Transmit FIFO, transmission will start regardless of the value in XMTSP. If the network interface is operating in half-duplex mode, regardless of XMTSP, the FIFO will not internally overwrite its data until at least 64 bytes (or the entire frame if shorter than 64 bytes) have been transmitted onto the network. This ensures that for collisions within the slot time window, transmit data need not be rewritten to the Transmit FIFO, and retries will be handled autonomously by the MAC. If the Disable Retry feature is enabled, or if the network is operating in full-duplex mode, the Am79C978A controller can overwrite the beginning of the frame as soon as

These bits are read/write accessible only when either the STOP or the SPND bit is set. XMTSP is set to a value of 01b (64 bytes) after H_RESET or S_RESET and is unaffected by STOP.

Table 34. Transmit Start Point Programming

XMTSP[1:0]	SRAM_SIZE	Bytes Written
00	0	20
01	0	64
10	0	128
11	0	220 max
00	>0	36
01	>0	64
10	>0	128
11	>0	Full Packet
XX	>0	Full Packet when NOUFLO bit is set

9-8 XMTFW[1:0] Transmit FIFO Watermark. XMTFW specifies the point at which transmit DMA is requested, based upon the number of bytes that could be written to the

Transmit FIFO without FIFO overflow. Transmit DMA is requested at any time when the number of bytes specified by XMTFW could be written to the FIFO without causing Transmit FIFO overflow and the internal microcode engine has reached a point where the Transmit FIFO is checked to determine if DMA servicing is required.

When operating in the NO-SRAM mode (no SRAM enabled) and SRAM_SIZE is set to 0, the Bus Transmit FIFO and the MAC Transmit FIFO operate like a single FIFO and the watermark value selected by XMTFW[1:0] sets the number of FIFO byte locations that must be available in the FIFO before receive DMA is requested.

When operating with the SRAM, the Bus Transmit FIFO and the MAC Transmit FIFO operate independently on the bus side and MAC side of the SRAM, respectively. In this case, the watermark value set by XMTFW[1:0] sets the number of FIFO byte locations that must be available in the Bus Transmit FIFO. See Table 35.

Table 35. Transmit Watermark Programming

XMTFW[1:0]	Bytes Available
00	16
01	64
10	108
11	Reserved

These bits are read/write accessible only when either the STOP or the SPND bit is set. XMTFW is set to a value of 00b (16 bytes) after H_RESET or S_RESET and is unaffected by STOP.

7-0 DMATC[7:0] DMA Transfer Counter. Writing and reading to this field has no effect. Use MAX_LAT and MIN_GNT in the PCI configuration space.

CSR82: Transmit Descriptor Address Pointer Lower

Bit	Name	Description
31-16	RES	Reserved locations. Written as zeros and read as undefined.
15-0	TXDAPL	Contains the lower 16 bits of the transmit descriptor address corresponding to the last buffer of the previous transmit frame. If the previous transmit frame did not use buffer chaining, then TXDAPL contains the lower 16 bits of the previous frame's transmit descriptor address. When both the STOP or SPND bits are cleared, this register is updated by the Am79C978A controller immediately before a transmit descriptor write. Read accessible always. Write accessible through the PXDAL bits (CSR60) when the STOP or SPND bit is set. TXDAPL is set to 0 by H_RESET and are unaffected by S_RESET or STOP.

CSR84: DMA Address Register Lower

Bit	Name	Description
31-16	RES	Reserved locations. Written as zeros and read as undefined.
15-0	DMABAL	This register contains the lower 16 bits of the address of system memory for the current DMA cycle. The Bus Interface Unit controls the Address Register by issuing increment commands to increment the memory address for sequential operations. The DMABAL register is undefined until the first Am79C978A controller DMA operation. These bits are read/write accessible only when either the STOP or the SPND bit is set. These bits are unaffected by H_RESET, S_RESET, or STOP.

CSR85: DMA Address Register Upper

Bit	Name	Description
31-16	RES	Reserved locations. Written as zeros and read as undefined.
15-0	DMABAU	This register contains the upper 16 bits of the address of system memory for the current DMA cycle. The Bus Interface Unit controls the Address Register by issuing increment commands to increment the memory address for sequential operations. The DMA-BAU register is undefined until the first Am79C978A controller DMA operation. These bits are read/write accessible only when either the STOP or the SPND bit is set. These bits are unaffected by H_RESET, S_RESET, or STOP.

27-12 PARTID

VER is read only. Write operations are ignored.

Part number. The 16-bit code for the Am79C978A controller is 0010 0110 0010 0110 (2626h).

This register is exactly the same as the Device ID register in the JTAG description. However, this part number is different from that stored in the Device ID register in the PCI configuration space.

Read accessible only when either the STOP or the SPND bit is set. PARTID is read only. Write operations are ignored.

11-1 MANFID

Manufacturer ID. The 11-bit manufacturer code for AMD is 00000000001b. This code is per the JEDEC Publication 106-A.

Note that this code is not the same as the Vendor ID in the PCI configuration space.

CSR86: Buffer Byte Counter

Bit	Name	Description
31-16	RES	Reserved locations. Written as zeros and read as undefined.
15-12	RES	Reserved. Read and written with ones.
11-0	DMABC	DMA Byte Count Register. Contains the two's complement of the current size of the remaining transmit or receive buffer in bytes. This register is incremented by the Bus Interface Unit. The DMABC register is undefined until written. These bits are read/write accessible only when either the STOP or the SPND bit is set. These bits are unaffected by H_RESET, S_RESET, or STOP.

0 ONE

Read accessible only when either the STOP or the SPND bit is set. VER is read only. MANFID is read only. Write operations are ignored.

Always a logic 1.

Read accessible only when either the STOP or the SPND bit is set. VER is read only. ONE is read only. Write operations are ignored.

CSR89: Chip ID Register Upper

Bit	Name	Description
31-16	RES	Reserved locations. Read as undefined.
15-12	VER	Version. This 4-bit pattern is silicon-revision dependent. Read accessible only when either the STOP or the SPND bit is set. VER is read only. Write operations are ignored.
11-0	PARTIDU	Upper 12 bits of the Am79C978A controller part number, i.e., 0010 0110 0010b (262h).

CSR88: Chip ID Register Lower

Bit	Name	Description
31-28	VER	Version. This 4-bit pattern is silicon-revision dependent. Read accessible only when either the STOP or the SPND bit is set.

Read accessible only when either the STOP or the SPND bit is set. VER is read only. PARTIDU is read only. Write operations are ignored.

CSR92: Ring Length Conversion

Bit	Name	Description
31-16	RES	Reserved locations. Written as zeros and read as undefined.
15-0	RCON	<p>Ring Length Conversion Register. This register performs a ring length conversion from an encoded value as found in the initialization block to a two's complement value used for internal counting. By writing bits 15-12 with an encoded ring length, a two's complemented value is read. The RCON register is undefined until written.</p> <p>These bits are read/write accessible only when either the STOP or the SPND bit is set. These bits are unaffected by H_RESET, S_RESET, or STOP.</p>

CSR100: Bus Timeout

Bit	Name	Description
31-16	RES	Reserved locations. Written as zeros and read as undefined.
15-0	MERRTO	<p>This register contains the value of the longest allowable bus latency (interval between assertion of \overline{REQ} and assertion of \overline{GNT}) that a system may insert into an Am79C978A controller master transfer. If this value of bus latency is exceeded, then a MERR will be indicated in CSR0, bit 11, and an interrupt may be generated, depending upon the setting of the MERRM bit (CSR3, bit 11) and the IENA bit (CSR0, bit 6).</p> <p>The value in this register is interpreted as the unsigned number of bus clock periods divided by two, (i.e., the value in this register is given in 0.1 ms increments). For example, the value 0600h (1536 decimal) will cause a MERR to be</p>

indicated after 153.6 ms of bus latency. A value of 0 will allow an infinitely long bus latency, i.e., bus timeout error will never occur.

These bits are read/write accessible only when either the STOP or the SPND bit is set. This register is set to 0600h by H_RESET or S_RESET and is unaffected by STOP.

CSR112: Missed Frame Count

Bit	Name	Description
31-16	RES	Reserved locations. Written as zeros and read as undefined.
15-0	MFC	<p>Missed Frame Count. Indicates the number of missed frames.</p> <p>MFC will roll over to a count of 0 from the value 65535. The MFCO bit of CSR4 (bit 8) will be set each time that this occurs.</p> <p>Read accessible always. MFC is read only, write operations are ignored. MFC is cleared by H_RESET, or S_RESET or by setting the STOP bit.</p>

CSR114: Receive Collision count

Bit	Name	Description
31-16	RES	Reserved locations. Written as zeros and read as undefined.
15-0	RCC	<p>Receive Collision Count. Indicates the total number of collisions encountered by the receiver since the last reset of the counter.</p> <p>RCC will roll over to a count of 0 from the value 65535. The RCVCCO bit of CSR4 (bit 5) will be set each time that this occurs.</p> <p>These bits are read accessible always. RCC is read only, write operations are ignored. RCC is cleared by H_RESET or S_RESET, or by setting the STOP bit.</p>

CSR116: OnNow Power Mode Register

Note: Bits 15-0 in this register are programmable through the EEPROM.

Bit	Name	Description
31-16	RES	Reserved locations. Written as zeros and read as undefined.
10	PME_EN_OVR	PME_EN Overwrite. When this bit is set and the MPMAT or LCDET bit is set, the PME pin will always be asserted regardless of the state of the PME_EN bit. These bits are read/write accessible only when either the STOP bit or the SPND bit is set. Cleared by H_RESET and is not affected by S_RESET or setting the STOP bit.
9	LCDET	Link Change Detected. This bit is set when the MII auto-polling logic detects a change in link status and the LCMODE bit is set. LCDET is cleared when power is initially applied (POR). This bit is always read/write accessible.
8	LCMODE	Link Change Wake-up Mode. When this bit is set to 1, the LCDET bit gets set when the MII auto polling logic detects a Link Change. Read/Write accessible only when either the STOP bit or the SPND bit is set. Cleared by H_RESET and is not affected by S_RESET or setting the STOP bit.
7	PMAT	Pattern Matched. This bit is set when the PMMODE bit is set and an OnNow pattern match occurs. PMAT is cleared when power is initially applied (POR). This bit is read accessible always.
6	EMPPLBA	Magic Packet Physical Logical Broadcast Accept. If both EMPPLBA and MPPLBA (CSR5, bit 5) are at their default value of 0, the Am79C978A controller will only detect a Magic Packet frame if the destination address of the

5	MPMAT	Magic Packet Match. This bit is set when the integrated Ethernet controller detects a Magic Packet while it is in Magic Packet mode. MPMAT is cleared when power is initially applied (POR). This bit is always read/write accessible.
4	MPPEN	Magic Packet Pin Enable. When this bit is set, the device enters the Magic Packet mode when the PG input goes LOW or MPEN bit (CSR5, bit 2) gets set to 1. This bit is OR'ed with MPEN bit (CSR5, bit 2). Read/Write accessible only when either the STOP bit or the SPND bit is set. Cleared by H_RESET and is not affected by S_RESET or setting the STOP bit.
3-1	RES	Reserved locations.
0	RST_POL	PHY_RST Pin Polarity. If the PHY_POL is set to 1, the PHY_RST pin is active LOW; otherwise PHY_RST is active HIGH. This bit is read/write accessible only when either the STOP bit or the PND bit is set. Cleared by H_RESET and is not affected by S_RESET or setting the STOP bit.

CSR122: Advanced Feature Control

Bit	Name	Description
31-1	RES	Reserved locations. Written as zeros and read as undefined.
0	RCVALGN	Receive Packet Align. When set, this bit forces the data field of ISO 8802-3 (IEEE/ANSI 802.3) packets to align to 0 MOD 4 address boundaries (i.e., DWord aligned addresses). It is important to note that this feature will only function correctly if all receive buffer boundaries are DWord aligned and all receive buffers have 0 MOD 4 lengths. In order to accomplish the data alignment, the Am79C978A controller simply inserts two bytes of random data at the beginning of the receive packet (i.e., before the ISO 8802-3 (IEEE/ANSI 802.3) destination address field). The MCNT field reported to the receive descriptor will not include the extra two bytes.

This bit is always read/write accessible. RCVALGN is cleared by H_RESET or S_RESET and is not affected by STOP.

CSR124: Test Register 1

This register is used to place the Am79C978A controller into various test modes. The Runt Packet Accept is the only user accessible test mode. All other test modes are for AMD internal use only.

Bit	Name	Description
31-4	RES	Reserved locations. Written as zeros and read as undefined.
3	RPA	Runt Packet Accept. This bit forces the Am79C978A controller to accept runt packets (packets shorter than 64 bytes). This bit is read accessible always; write accessible only when STOP is set to 1. RPA is cleared by H_RESET or S_RESET and is not affected by STOP.
2-0	RES	Reserved locations. Written as zeros and read as undefined.

CSR125: MAC Enhanced Configuration Control

Bit	Name	Description
31-16	RES	Reserved locations. Written as zeros and read as undefined.
15-8	IPG	Inter Packet Gap. Changing IPG allows the user to program the Am79C978A controller for aggressiveness on a network. By changing the default value of 96 bit times (60h) the user can adjust the fairness or aggressiveness of the Am79C978A integrated MAC on the network. By programming a lower number of bit times other than the ISO/IEC 8802-3 standard requires, the Am79C978A controller will become more aggressive on the network. This aggressive nature will give rise to the Am79C978A controller possibly "capturing the network" at times by forcing other less aggressive nodes to defer. By programming a larger number of bit times, the Am79C978A home networking MAC will become less aggressive on the network and may defer more often than normal. The performance of the Am79C978A controller may decrease as the IPG value is increased from the default value.

Note: Programming of the IPG should be done in nibble intervals instead of absolute bit times. The decimal and hex values do not match due to delays in the part used to make up the final IPG. Changes should be added or subtracted from the provided hex value on a one-for-one basis.

CAUTION: Use this parameter with care. By lowering the IPG below the ISO/IEC 8802-3 standard 96 bit times, the Am79C978A controller can interrupt normal network behavior.

These bits are read accessible always. Write accessible when the STOP bit is set to 1. IPG is set to 60h (96 Bit times) by H_RESET

		or S_RESET and is not affected by STOP.	
7-0	IFS1	<p>InterFrameSpacingPart1. Changing IFS1 allows the user to program the value of the InterFrameSpacePart1 timing. The Am79C978A controller sets the default value at 60 bit times (3ch). See the subsection on <i>Medium Allocation</i> in the section <i>Media Access Management</i> for more details. The equation for setting IFS1 when $IPG \geq 96$ bit times is:</p> $IFS1 = IPG - 36 \text{ bit times}$ <p>Note: <i>Programming of the IPG should be done in nibble intervals instead of absolute bit times due</i></p>	<p><i>to the MII. The decimal and hex values do not match due to delays in the part used to make up the final IPG.</i></p> <p><i>Changes should be added or subtracted from the provided hex value on a one-for-one basis. Due to changes in synchronization delays internally through different network ports, the IFS1 can be off by as much as +12 bit times.</i></p> <p>These bits are read accessible always. Write accessible only when the SPND bit or the STOP bit is set to 1. IFS1 is set to 3ch (60 bit times) by H_RESET or S_RESET and is not affected by STOP.</p>

Bus Configuration Registers (BCRs)

The BCRs are used to program the configuration of the bus interface and other special features of the Am79C978A controller that are not related to the IEEE 802.3 MAC functions. The BCRs are accessed by first setting the appropriate RAP value and then by performing a slave access to the BDP. See Table 36.

All BCR registers are 16 bits in width in Word I/O mode (DWIO = 0, BCR18, bit 7) and 32 bits in width in DWord I/O mode (DWIO = 1). The upper 16 bits of all BCR registers is undefined when in DWord I/O mode. These bits should be written as zeros and should be treated as undefined when read. The default value given for any BCR is the value in the register after H_RESET. Some of these values may be changed shortly after H_RESET when the contents of the external EEPROM is automatically read in. None of the BCR register values are affected by the assertion of the STOP bit or S_RESET.

Note that several registers have no default value. BCR0, BCR1, BCR3, BCR8, BCR10-17, and BCR21 are reserved and have undefined values. BCR2 and BCR34 are not observable without first being programmed through the EEPROM read operation or a user register write operation.

BCR0, BCR1, BCR16, BCR17, and BCR21 are registers that are used by other devices in the PCnet family. Writing to these registers have no effect on the operation of the Am79C978A controller.

Writes to those registers marked as “Reserved” will have no effect. Reads from these locations will produce undefined values.

BCR0: Master Mode Read Active

Bit	Name	Description
31-16	RES	Reserved locations. Written as zeros and read as undefined.
15-0	MSRDA	Reserved locations. After H_RESET, the value in this register will be 0005h. The setting of this register has no effect on any Am79C978A controller function. It is only included for software compatibility with other PCnet family devices. Read always. MSRDA is read only. Write operations have no effect.

BCR1: Master Mode Write Active

Bit	Name	Description
31-16	RES	Reserved locations. Written as zeros and read as undefined.
15-0	MSWRA	Reserved locations. After H_RESET, the value in this register will be 0005h. The setting of this register has no effect on any Am79C978A controller function. It is only included for software compatibility with other PCnet family devices. Read always. MSWRA is read only. Write operations have no effect.

Table 36. BCR Registers

RAP	Mnemonic	Default	Name	Programmability	
				User	EEPROM
0	MSRDA	0005h	Reserved	No	No
1	MSWRA	0005h	Reserved	No	No
2	MC	0002h	Miscellaneous Configuration	Yes	Yes
3	Reserved	N/A	Reserved	No	No
4	LED0	00C0h	LED0 Status	Yes	Yes
5	LED1	0084h	LED1 Status	Yes	Yes
6	LED2	0088h	LED2 Status	Yes	Yes
7	LED3	0090h	LED3 Status	Yes	Yes
8	Reserved	N/A	Reserved	No	No
9	FDC	0000h	Full-Duplex Control	Yes	Yes
10-15	Reserved	N/A	Reserved	No	No
16	IOBASEL	N/A	Reserved	No	No
17	IOBASEU	N/A	Reserved	No	No
18	BSBC	9001h	Burst and Bus Control	Yes	Yes
19	EECAS	0002h	EEPROM Control and Status	Yes	No
20	SWS	0000h	Software Style	Yes	No
21	INTCON	N/A	Reserved	No	No
22	PCILAT	FF06h	PCI Latency	Yes	Yes
23	PCISID	0000h	PCI Subsystem ID	No	Yes
24	PCISVID	0000h	PCI Subsystem Vendor ID	No	Yes
25	SRAMSIZ	0000h	SRAM Size	Yes	Yes
26	SRAMB	0000h	SRAM Boundary	Yes	Yes
27	SRAMIC	0000h	SRAM Interface Control	Yes	Yes
28	EBADDRL	N/A	Expansion Bus Address Lower	Yes	No
29	EBADDRU	N/A	Expansion Bus Address Upper	Yes	No
30	EBD	N/A	Expansion Bus Data Port	Yes	No
31	STVAL	FFFFh	Software Timer Value	Yes	No
32	MIICAS	0000h	PHY Control and Status	Yes	Yes
33	MIIADDR	0000h	PHY Address	Yes	Yes
34	MIIIMDR	N/A	PHY Management Data	Yes	No
35	PCIVID	1022h	PCI Vendor ID	No	Yes
36	PMC_A	C811h	PCI Power Management Capabilities (PMC) Alias Register	No	Yes
37	DATA0	0000h	PCI DATA Register 0 Alias Register	No	Yes
38	DATA1	0000h	PCI DATA Register 1 Alias Register	No	Yes
39	DATA2	0000h	PCI DATA Register 2 Alias Register	No	Yes
40	DATA3	0000h	PCI DATA Register 3 Alias Register	No	Yes
41	DATA4	0000h	PCI DATA Register 4 Alias Register	No	Yes
42	DATA5	0000h	PCI DATA Register 5 Alias Register	No	Yes
43	DATA6	0000h	PCI DATA Register 6 Alias Register	No	Yes
44	DATA7	0000h	PCI DATA Register 7 Alias Register	No	Yes
45	PMR1	N/A	Pattern Matching Register 1	Yes	No
46	PMR2	N/A	Pattern Matching Register 2	Yes	No
47	PMR3	N/A	Pattern Matching Register 3	Yes	No
48	LED4	0082h	LED4 Status	Yes	Yes
49	PHY Select	8101h	PHY Select	Yes	Yes

BCR2: Miscellaneous Configuration

Note: Bits 15-0 in this register are programmable through the EEPROM.

Bit	Name	Description			
31-16	RES	Reserved locations. Written as zeros and read as undefined.			
15-14	RES	Reserved locations. Written and read as zeros.	7	INTLEVEL	Interrupt Level. This bit allows the interrupt output signals to be programmed for level or edge-sensitive applications.
13	PHYSELEN	This bit enables writes to BCR18[4:3] for software selection of various operation and test modes. When PHYSELEN is set to 0 (default), the two bits can only be written from the EEPROM. When PHYSELEN is set to 1, writes to BCR18[4:3] are enabled. This bit is always read/write accessible. TSTSHDEN is cleared to 0 by H_RESET and is unaffected by S_RESET or by setting the STOP bit.			When INTLEVEL is cleared to 0, the $\overline{\text{INTA}}$ pin is configured for level-sensitive applications. In this mode, an interrupt request is signaled by a low level driven on the $\overline{\text{INTA}}$ pin by the Am79C978A controller. When the interrupt is cleared, the $\overline{\text{INTA}}$ pin is tri-stated by the Am79C978A controller and allowed to be pulled to a high level by an external pullup device. This mode is intended for systems which allow the interrupt signal to be shared by multiple devices.
12	LEDPE	LED Program Enable. When LEDPE is set to 1, programming of the LED0 (BCR4), LED1 (BCR5), LED2 (BCR6), LED3 (BCR7), and LED4 (BCR48) registers is enabled. When LEDPE is cleared to 0, programming of LED0 (BCR4), LED1 (BCR5), LED2 (BCR6), LED3 (BCR7), and LED4 (BCR48) registers is disabled. Writes to those registers will be ignored. This bit is always read/write accessible. LEDPE is cleared to 0 by H_RESET and is unaffected by S_RESET or by setting the STOP bit.			When INTLEVEL is set to 1, the $\overline{\text{INTA}}$ pin is configured for edge-sensitive applications. In this mode, an interrupt request is signaled by a high level driven on the $\overline{\text{INTA}}$ pin by the Am79C978A controller. When the interrupt is cleared, the $\overline{\text{INTA}}$ pin is driven to a low level by the Am79C978A controller. This mode is intended for systems that do not allow interrupt channels to be shared by multiple devices.
11-9	RES	Reserved locations. Written and read as zeros.			INTLEVEL should not be set to 1 when the Am79C978A controller is used in a PCI bus application.
8	APROMWE	Address PROM Write Enable. The Am79C978A controller contains a shadow RAM on board for storage of the first 16 bytes loaded from the serial EEPROM. Accesses to Address PROM I/O Resources will be directed toward this RAM. When APROMWE is			This bit is always read/write accessible. INTLEVEL is cleared to 0 by H_RESET and is unaffected by S_RESET or by setting the STOP bit.
			6-3	RES	Reserved locations. Written as zeros and read as undefined.
			2-0	RES	Reserved locations. Written and read as zeros.

BCR4: LED0 Status

BCR4 controls the function(s) that the $\overline{\text{LED0}}$ pin displays. Multiple functions can be simultaneously enabled on this LED pin. The LED display will indicate the logical OR of the enabled functions. BCR4 defaults to Link Status (LNKST) with pulse stretcher enabled (PSE = 1) and is fully programmable.

Note: When LEDPE (BCR2, bit 12) is set to 1, programming of the LED0 Status register is enabled. When LEDPE is cleared to 0, programming of the LED0 register is disabled. Writes to those registers will be ignored.

Note: Bits 15-0 in this register are programmable through the EEPROM.

Bit	Name	Description
31-16	RES	Reserved locations. Written as zeros and read as undefined.
15	LEDOUT	<p>This bit indicates the current (non-stretched) value of the LED output pin. A value of 1 in this bit indicates that the OR of the enabled signals is true.</p> <p>The logical value of the LEDOUT status signal is determined by the settings of the individual Status Enable bits of the LED register (bits 8 and 6-0).</p> <p>This bit is read accessible always. This bit is read only; writes have no effect. LEDOUT is unaffected by H_RESET, S_RESET, or STOP.</p>
14	LEDPOL	<p>LED Polarity. When this bit has the value 0, then the LED pin will be driven to a LOW level whenever the OR of the enabled signals is true, and the LED pin will be disabled and allowed to float high whenever the OR of the enabled signals is false (i.e., the LED output will be an Open Drain output and the output value will be the inverse of the LEDOUT status bit).</p> <p>When this bit has the value 1, then the LED pin will be driven to a HIGH level whenever the OR of the enabled signals is true, and the LED pin will be driven to a LOW level whenever the OR of</p>

the enabled signals is false (i.e., the LED output will be a Totem Pole output and the output value will be the same polarity as the LEDOUT status bit).

The setting of this bit will not effect the polarity of the LEDOUT bit for this register.

This bit is always read/write accessible. LEDPOL is cleared by H_RESET and is not affected by S_RESET or setting the STOP bit.

13	LEDDIS	<p>LED Disable. This bit is used to disable the LED output. When LEDDIS has the value 1, then the LED output will always be disabled. When LEDDIS has the value 0, then the LED output value will be governed by the LEDOUT and LEDPOL values.</p> <p>This bit is always read/write accessible. LEDDIS is cleared by H_RESET and is not affected by S_RESET or setting the STOP bit.</p>
----	--------	--

12	100E	<p>100 Mbps Enable. When this bit is set to 1, a value of 1 is passed to the LEDOUT bit in this register when the Am79C978A controller is operating at 100 Mbps mode.</p> <p>This bit is always read/write accessible. 100E is cleared by H_RESET and is not affected by S_RESET or setting the STOP bit.</p>
----	------	---

11-10	RES	Reserved locations. Written and read as zeros.
-------	-----	--

9	MPSE	<p>Magic Packet Status Enable. When this bit is set to 1, a value of 1 is passed to the LEDOUT bit in this register when Magic Packet frame mode is enabled and a Magic Packet frame is detected on the network.</p> <p>This bit is always read/write accessible. MPSE is cleared by H_RESET and is not affected by S_RESET or setting the STOP bit.</p>
---	------	--

8	FDLSE	<p>Full-Duplex Link Status Enable. Indicates the Full-Duplex Link Test Status. When this bit is set, a value of 1 is passed to the LEDOUT signal when the Am79C978A controller is functioning in a Link Pass state and full-duplex operation is enabled. When the Am79C978A controller is not functioning in a Link Pass state with full-duplex operation being enabled, a value of 0 is passed to the LEDOUT signal.</p> <p>This bit is always read/write accessible. FDLSE is cleared by H_RESET and is not affected by S_RESET or setting the STOP bit.</p>	<p>by S_RESET or setting the STOP bit.</p>		
			4	XMTE	<p>Transmit Status Enable. When this bit is set, a value of 1 is passed to the LEDOUT bit in this register when there is transmit activity on the network.</p> <p>This bit is always read/write accessible. XMTE is cleared by H_RESET and is not affected by S_RESET or setting the STOP bit.</p>
			3	POWER	<p>Power. When this bit is set to 1, the device is operating in HIGH power mode.</p>
7	PSE	<p>Pulse Stretcher Enable. When this bit is set, the LED illumination time is extended for each new occurrence of the enabled function for this LED output. A value of 0 disables the pulse stretcher.</p> <p>This bit is always read/write accessible. PSE is set to 1 by H_RESET and is not affected by S_RESET or setting the STOP bit.</p>	2	RCVE	<p>Receive Status Enable. When this bit is set, a value of 1 is passed to the LEDOUT bit in this register when there is receive activity on the network.</p> <p>This bit is always read/write accessible. RCVE is cleared by H_RESET and is not affected by S_RESET or setting the STOP bit.</p>
			1	SPEED	<p>Speed. When this bit is set to 1, the device is operating in HIGH speed mode.</p>
6	LNKSE	<p>Link Status Enable. When this bit is set, a value of 1 will be passed to the LEDOUT bit in this register when in Link Pass state.</p> <p>This bit is always read/write accessible. LNKSE is set to 1 by H_RESET and is not affected by S_RESET or setting the STOP bit.</p>	0	COLE	<p>Collision Status Enable. When this bit is set, a value of 1 is passed to the LEDOUT bit in this register when there is collision activity on the network.</p> <p>This bit is always read/write accessible. COLE is cleared by H_RESET and is not affected by S_RESET or setting the STOP bit.</p>
5	RCVME	<p>Receive Match Status Enable. When this bit is set, a value of 1 is passed to the LEDOUT bit in this register when there is receive activity on the network that has passed the address match function for this node. All address matching modes are included: physical, logical filtering, broadcast, and promiscuous.</p> <p>This bit is always read/write accessible. RCVME is cleared by H_RESET and is not affected</p>			

BCR5: LED1 Status

BCR5 controls the function(s) that the $\overline{\text{LED1}}$ pin displays. Multiple functions can be simultaneously enabled on this LED pin. The LED display will indicate the logical OR of the enabled functions. BCR5 defaults to Receive Status (RCV) with pulse stretcher enabled (PSE = 1) and is fully programmable.

Note: When LEDPE (BCR2, bit 12) is set to 1, programming of the LED1 Status register is enabled. When LEDPE is cleared to 0, programming of the

LED1 register is disabled. Writes to those registers will be ignored.

Note: Bits 15-0 in this register are programmable through the EEPROM.

Bit	Name	Description			
31-16	RES	Reserved locations. Written as zeros and read as undefined.			
15	LEDOUT	<p>This bit indicates the current (non-stretched) value of the LED output pin. A value of 1 in this bit indicates that the OR of the enabled signals is true.</p> <p>The logical value of the LEDOUT status signal is determined by the settings of the individual Status Enable bits of the LED register (bits 8 and 6-0).</p> <p>This bit is always read accessible. This bit is read only; writes have no effect. LEDOUT is unaffected by H_RESET, S_RESET, or STOP.</p>	13	LEDDIS	<p>LED Disable. This bit is used to disable the LED output. When LEDDIS has the value 1, then the LED output will always be disabled. When LEDDIS has the value 0, then the LED output value will be governed by the LEDOUT and LEDPOL values.</p> <p>This bit is always read/write accessible. LEDDIS is cleared by H_RESET and is not affected by S_RESET or setting the STOP bit.</p>
14	LEDPOL	<p>LED Polarity. When this bit has the value 0, then the LED pin will be driven to a LOW level whenever the OR of the enabled signals is true, and the LED pin will be disabled and allowed to float high whenever the OR of the enabled signals is false (i.e., the LED output will be an Open Drain output and the output value will be the inverse of the LEDOUT status bit).</p> <p>When this bit has the value 1, then the LED pin will be driven to a HIGH level whenever the OR of the enabled signals is true, and the LED pin will be driven to a LOW level whenever the OR of the enabled signals is false (i.e., the LED output will be a Totem Pole output and the output value will be the same polarity as the LEDOUT status bit).</p> <p>The setting of this bit will not effect the polarity of the LEDOUT bit for this register.</p> <p>This bit is always read/write accessible. LEDPOL is cleared by</p>	12	100E	<p>100 Mbps Enable. When this bit is set to 1, a value of 1 is passed to the LEDOUT bit in this register when the Am79C978A controller is operating at 100 Mbps mode.</p> <p>This bit is always read/write accessible. 100E is cleared by H_RESET and is not affected by S_RESET or setting the STOP bit.</p>
			11-10	RES	Reserved locations. Written and read as zeros.
			9	MPSE	<p>Magic Packet Status Enable. When this bit is set to 1, a value of 1 is passed to the LEDOUT bit in this register when Magic Packet mode is enabled and a Magic Packet frame is detected on the network.</p> <p>This bit is always read/write accessible. MPSE is cleared by H_RESET and is not affected by S_RESET or setting the STOP bit.</p>
			8	FDLSE	<p>Full-Duplex Link Status Enable. Indicates the Full-Duplex Link Test Status. When this bit is set, a value of 1 is passed to the LEDOUT signal when the Am79C978A controller is functioning in a Link Pass state and full-duplex operation is enabled. When the Am79C978A controller is not functioning in a Link Pass state with full-duplex</p>

		operation being enabled, a value of 0 is passed to the LED-OUT signal.			H_RESET and is not affected by S_RESET or setting the STOP bit.
		This bit is always read/write accessible. FDLSE is cleared by H_RESET and is not affected by S_RESET or setting the STOP bit.	3	POWER	Power. When this bit is set to 1, the device is operating in HIGH power mode.
7	PSE	Pulse Stretcher Enable. When this bit is set, the LED illumination time is extended for each new occurrence of the enabled function for this LED output. A value of 0 disables the pulse stretcher.			Receive Status Enable. When this bit is set, a value of 1 is passed to the LEDOUT bit in this register when there is receive activity on the network.
		This bit is always read/write accessible. PSE is set to 1 by H_RESET and is not affected by S_RESET or setting the STOP bit.			This bit is always read/write accessible. RCVE is set to 1 by H_RESET and is not affected by S_RESET or setting the STOP bit.
			1	SPEED	Speed. When this bit is set to 1, the device is operating in HIGH speed mode.
6	LNKSE	Link Status Enable. When this bit is set, a value of 1 will be passed to the LEDOUT bit in this register in Link Pass state.			Collision Status Enable. When this bit is set, a value of 1 is passed to the LEDOUT bit in this register when there is collision activity on the network.
		This bit is always read/write accessible. LNKSE is cleared by H_RESET and is not affected by S_RESET or setting the STOP bit.			This bit is always read/write accessible. COLE is cleared by H_RESET and is not affected by S_RESET or setting the STOP bit.
5	RCVME	Receive Match Status Enable. When this bit is set, a value of 1 is passed to the LEDOUT bit in this register when there is receive activity on the network that has passed the address match function for this node. All address matching modes are included: physical, logical filtering, broadcast, and promiscuous.			
		This bit is always read/write accessible. RCVME is cleared by H_RESET and is not affected by S_RESET or setting the STOP bit.			
4	XMTE	Transmit Status Enable. When this bit is set, a value of 1 is passed to the LEDOUT bit in this register when there is transmit activity on the network.			
		This bit is always read/write accessible. XMTE is cleared by			

BCR6: LED2 Status

BCR6 controls the function(s) that the $\overline{\text{LED2}}$ pin displays. Multiple functions can be simultaneously enabled on this LED pin. The LED display will indicate the logical OR of the enabled functions.

Note: When LEDPE (BCR2, bit 12) is set to 1, programming of the LED2 Status register is enabled. When LEDPE is cleared to 0, programming of the LED2 register is disabled. Writes to those registers will be ignored.

Note: Bits 15-0 in this register are programmable through the EEPROM PREAD operation.

Bit	Name	Description
31-16	RES	Reserved locations. Written as zeros and read as undefined.
15	LEDOUT	This bit indicates the current (non-stretched) value of the LED output pin. A value of 1 in

		<p>this bit indicates that the OR of the enabled signals is true.</p> <p>The logical value of the LEDOUT status signal is determined by the settings of the individual Status Enable bits of the LED register (bits 8 and 6-0).</p> <p>This bit is read accessible always. This bit is read only; writes have no effect. LEDOUT is unaffected by H_RESET, S_RESET, or STOP.</p>			<p>This bit is always read/write accessible. LEDDIS is cleared by H_RESET and is not affected by S_RESET or setting the STOP bit.</p>
14	LEDPOL	<p>LED Polarity. When this bit has the value 0, then the LED pin will be driven to a LOW level whenever the OR of the enabled signals is true, and the LED pin will be disabled and allowed to float high whenever the OR of the enabled signals is false (i.e., the LED output will be an Open Drain output and the output value will be the inverse of the LEDOUT status bit).</p> <p>When this bit has the value 1, then the LED pin will be driven to a HIGH level whenever the OR of the enabled signals is true, and the LED pin will be driven to a LOW level whenever the OR of the enabled signals is false (i.e., the LED output will be a Totem Pole output and the output value will be the same polarity as the LEDOUT status bit).</p> <p>The setting of this bit will not effect the polarity of the LEDOUT bit for this register.</p> <p>This bit is always read/write accessible. LEDPOL is cleared by H_RESET and is not affected by S_RESET or setting the STOP bit.</p>	12	100E	<p>100 Mbps Enable. When this bit is set to 1, a value of 1 is passed to the LEDOUT bit in this register when the Am79C978A controller is operating at 100 Mbps mode.</p> <p>This bit is always read/write accessible. 100E is cleared by H_RESET and is not affected by S_RESET or setting the STOP bit.</p>
			11-10	RES	<p>Reserved locations. Written and read as zeros.</p>
			9	MPSE	<p>Magic Packet Status Enable. When this bit is set to 1, a value of 1 is passed to the LEDOUT bit in this register when Magic Packet frame mode is enabled and a Magic Packet frame is detected on the network.</p> <p>This bit is always read/write accessible. MPSE is cleared by H_RESET and is not affected by S_RESET or setting the STOP bit.</p>
			8	FDLSE	<p>Full-Duplex Link Status Enable. Indicates the Full-Duplex Link Test Status. When this bit is set, a value of 1 is passed to the LEDOUT signal when the Am79C978A controller is functioning in a Link Pass state and full-duplex operation is enabled. When the Am79C978A controller is not functioning in a Link Pass state with full-duplex operation being enabled, a value of 0 is passed to the LEDOUT signal.</p> <p>This bit is always read/write accessible. FDLSE is cleared by H_RESET and is not affected by S_RESET or setting the STOP bit.</p>
13	LEDDIS	<p>LED Disable. This bit is used to disable the LED output. When LEDDIS has the value 1, then the LED output will always be disabled. When LEDDIS has the value 0, then the LED output value will be governed by the LEDOUT and LEDPOL values.</p>	7	PSE	<p>Pulse Stretcher Enable. When this bit is set, the LED illumination time is extended for each new occurrence of the enabled function for this LED output. A value of 0 disables the pulse stretcher.</p>

		This bit is always read/write accessible. PSE is set to 1 by H_RESET and is not affected by S_RESET or setting the STOP bit.			by S_RESET or setting the STOP bit.
6	LNKSE	Link Status Enable. When this bit is set, a value of 1 will be passed to the LEDOUT bit in this register in Link Pass state. This bit is always read/write accessible. LNKSE is cleared by H_RESET and is not affected by S_RESET or setting the STOP bit.	1	SPEED	Speed. When this bit is set to 1, the device is operating in HIGH speed mode.
			0	COLE	Collision Status Enable. When this bit is set, a value of 1 is passed to the LEDOUT bit in this register when there is collision activity on the network. This bit is always read/write accessible. COLE is cleared by H_RESET and is not affected by S_RESET or setting the STOP bit.
5	RCVME	Receive Match Status Enable. When this bit is set, a value of 1 is passed to the LEDOUT bit in this register when there is receive activity on the network that has passed the address match function for this node. All address matching modes are included: physical, logical filtering, broadcast, and promiscuous. This bit is always read/write accessible. RCVME is cleared by H_RESET and is not affected by S_RESET or setting the STOP bit.			
4	XMTE	Transmit Status Enable. When this bit is set, a value of 1 is passed to the LEDOUT bit in this register when there is transmit activity on the network. This bit is always read/write accessible. XMTE is cleared by H_RESET and is not affected by S_RESET or setting the STOP bit.			
3	POWER	Power. When this bit is set to 1, the device is operating in HIGH power mode.			The logical value of the LEDOUT status signal is determined by the settings of the individual Status Enable bits of the LED register (bits 8 and 6-0).
2	RCVE	Receive Status Enable. When this bit is set, a value of 1 is passed to the LEDOUT bit in this register when there is receive activity on the network. This bit is always read/write accessible. RCVE is set to 1 by H_RESET and is not affected			This bit is read accessible always. This bit is read only; writes have no effect. LEDOUT is unaffected by H_RESET, S_RESET, or STOP.

BCR7: LED3 Status

BCR7 controls the function(s) that the $\overline{\text{LED3}}$ pin displays. Multiple functions can be simultaneously enabled on this LED pin. The LED display will indicate the logical OR of the enabled functions. BCR7 defaults to Transmit Status (XMT) with pulse stretcher enabled (PSE = 1) and is fully programmable.

Note: When LEDPE (BCR2, bit 12) is set to 1, programming of the LED3 Status register is enabled. When LEDPE is cleared to 0, programming of the LED3 register is disabled. Writes to those registers will be ignored.

Note: Bits 15-0 in this register are programmable through the EEPROM.

Bit	Name	Description
31-16	RES	Reserved locations. Written as zeros and read as undefined.
15	LEDOUT	This bit indicates the current (non-stretched) value of the LED output pin. A value of 1 in this bit indicates that the OR of the enabled signals is true.

14	LEDPOL	<p>LED Polarity. When this bit has the value 0, then the LED pin will be driven to a LOW level whenever the OR of the enabled signals is true, and the LED pin will be disabled and allowed to float high whenever the OR of the enabled signals is false (i.e., the LED output will be an Open Drain output and the output value will be the inverse of the LEDOUT status bit.).</p> <p>When this bit has the value 1, then the LED pin will be driven to a HIGH level whenever the OR of the enabled signals is true, and the LED pin will be driven to a LOW level whenever the OR of the enabled signals is false (i.e., the LED output will be a Totem Pole output and the output value will be the same polarity as the LEDOUT status bit).</p> <p>The setting of this bit will not effect the polarity of the LEDOUT bit for this register.</p> <p>This bit is always read/write accessible. LEDPOL is cleared by H_RESET and is not affected by S_RESET or setting the STOP bit.</p>	11-10 RES	by S_RESET or setting the STOP bit.
			9 MPSE	<p>Reserved locations. Written and read as zeros.</p> <p>Magic Packet Status Enable. When this bit is set to 1, a value of 1 is passed to the LEDOUT bit in this register when magic frame mode is enabled and a magic frame is detected on the network.</p> <p>This bit is always read/write accessible. MPSE is cleared by H_RESET and is not affected by S_RESET or setting the STOP bit.</p>
			8 FDLSE	<p>Full-Duplex Link Status Enable. Indicates the Full-Duplex Link Test Status. When this bit is set, a value of 1 is passed to the LEDOUT signal when the Am79C978A controller is functioning in a Link Pass state and full-duplex operation is enabled. When the Am79C978A controller is not functioning in a Link Pass state with full-duplex operation being enabled, a value of 0 is passed to the LEDOUT signal.</p> <p>This bit is always read/write accessible. FDLSE is cleared by H_RESET and is not affected by S_RESET or setting the STOP bit.</p>
13	LEDDIS	<p>LED Disable. This bit is used to disable the LED output. When LEDDIS has the value 1, then the LED output will always be disabled. When LEDDIS has the value 0, then the LED output value will be governed by the LEDOUT and LEDPOL values.</p> <p>This bit is always read/write accessible. LEDDIS is cleared by H_RESET and is not affected by S_RESET or setting the STOP bit.</p>	7 PSE	<p>Pulse Stretcher Enable. When this bit is set, the LED illumination time is extended for each new occurrence of the enabled function for this LED output. A value of 0 disables the pulse stretcher.</p> <p>This bit is always read/write accessible. PSE is set to 1 by H_RESET and is not affected by S_RESET or setting the STOP bit.</p>
12	100E	<p>100 Mbps Enable. When this bit is set to 1, a value of 1 is passed to the LEDOUT bit in this register when the Am79C978A controller is operating at 100 Mbps mode.</p> <p>This bit is always read/write accessible. 100E is cleared by H_RESET and is not affected</p>	6 LNKSE	<p>Link Status Enable. When this bit is set, a value of 1 will be passed to the LEDOUT bit in this register in Link Pass state.</p> <p>This bit is always read/write accessible. LNKSE is cleared by H_RESET and is not affected</p>

		by S_RESET or setting the STOP bit.
5	RCVME	<p>Receive Match Status Enable. When this bit is set, a value of 1 is passed to the LEDOUT bit in this register when there is receive activity on the network that has passed the address match function for this node. All address matching modes are included: physical, logical filtering, broadcast, and promiscuous.</p> <p>This bit is always read/write accessible. RCVME is cleared by H_RESET and is not affected by S_RESET or setting the STOP bit.</p>
4	XMTE	<p>Transmit Status Enable. When this bit is set, a value of 1 is passed to the LEDOUT bit in this register when there is transmit activity on the network.</p> <p>This bit is always read/write accessible. XMTE is set to 1 by H_RESET and is not affected by S_RESET or setting the STOP bit.</p>
3	POWER	Power. When this bit is set to 1, the device is operating in HIGH power mode.
2	RCVE	<p>Receive Status Enable. When this bit is set, a value of 1 is passed to the LEDOUT bit in this register when there is receive activity on the network.</p> <p>This bit is always read/write accessible. RCVE is cleared by H_RESET and is not affected by S_RESET or setting the STOP bit.</p>
1	SPEED	Speed. When this bit is set to 1, the device is operating in HIGH speed mode.
0	COLE	Collision Status Enable. When this bit is set, a value of 1 is passed to the LEDOUT bit in this register when there is collision activity on the network.

This bit is always read/write accessible. COLE is cleared by H_RESET and is not affected by S_RESET or setting the STOP bit.

BCR9: Full-Duplex Control

Note: Bits 15-0 in this register are programmable through the EEPROM.

Bit	Name	Description
31-3	RES	Reserved locations. Written as zeros and read as undefined.
2	FDRPAD	<p>Full-Duplex Runt Packet Accept Disable. When FDRPAD is set to 1 and full-duplex mode is enabled, the Am79C978A controller will only receive frames that meet the minimum Ethernet frame length of 64 bytes. Receive DMA will not start until at least 64 bytes or a complete frame have been received. By default, FDRPAD is cleared to 0. The Am79C978A controller will accept any length frame and receive DMA will start according to the programming of the receive FIFO watermark. Note that there should not be any runt packets in a full-duplex network, since the main cause for runt packets is a network collision and there are no collisions in a full-duplex network.</p> <p>This bit is always read/write accessible. FDRPAD is cleared by H_RESET and is not affected by S_RESET or by setting the STOP bit.</p>
1	RES	Reserved locations. Written as zeros and read as undefined.
0	FDEN	<p>Full-Duplex Enable. FDEN controls whether full-duplex operation is enabled. When FDEN is cleared and the Auto-Negotiation is disabled, full-duplex operation is not enabled and the Am79C978A controller will always operate in half-duplex mode. When FDEN is set, the Am79C978A controller will operate in full-duplex mode.</p>

Note: Do not set this bit when Auto-Negotiation is enabled.

This bit is always read/write accessible. FDEN is reset to 0 by H_RESET, and is unaffected by S_RESET and the STOP bit.

BCR16: I/O Base Address Lower

Bit	Name	Description
31-16	RES	Reserved locations. Written as zeros and read as undefined.
15-5	IOBASEL	Reserved locations. After H_RESET, the value of these bits will be undefined. The settings of these bits will have no effect on any Am79C978A controller function. These bits are always read/write accessible. IOBASEL is not affected by S_RESET or STOP.
4-0	RES	Reserved locations. Written as zeros, read as undefined.

BCR17: I/O Base Address Upper

Bit	Name	Description
31-16	RES	Reserved locations. Written as zeros and read as undefined.
15-0	IOBASEU	Reserved locations. After H_RESET, the value in this register will be undefined. The settings of this register will have no effect on any Am79C978A controller function. This bit is always read/write accessible. IOBASEU is not affected by S_RESET or STOP.

BCR18: Burst and Bus Control Register

Note: Bits 15-0 in this register are programmable through the EEPROM.

Bit	Name	Description
31-16	RES	Reserved locations. Written as zeros and read as undefined.
15-12	ROMTMG	Expansion ROM Timing. The value of ROMTMG is used to tune the timing for all EBDATA (BCR30) accesses to Flash/

EPROM as well as all Expansion ROM accesses to Flash/EPROM.

ROMTMG, during read operations, defines the time from when the Am79C978A controller drives the lower 8 or 16 bits of the Expansion Bus Address bus to when the Am79C978A controller latches in the data on the 8 or 16 bits of the Expansion Bus Data inputs. ROMTMG, during write operations, defines the time from when the Am79C978A controller drives the lower 8 or 16 bits of the Expansion Bus Data to when the EBWE and EROMCS deassert.

The register value specifies the time in number of clock cycles +1 according to Table 37.

Table 37. ROMTNG Programming Values

ROMTMG (bits 15-12)	No. of Expansion Bus Cycles
1h <= n <= Fh	n + 1

Note: Programming ROMTNG with a value of 0 is not permitted.

The access time for the Expansion ROM or the EBDATA (BCR30) device (t_{ACC}) during read operations can be calculated by subtracting the clock to output delay for the EBUA_EBA[7:0] outputs ($t_{v_A_D}$) and by subtracting the input to clock setup time for the EBD[7:0] inputs (t_{s_D}) from the time defined by ROMTMG:

$$t_{ACC} = \text{ROMTMG} * \text{CLK period} * \text{CLK_FAC} - (t_{v_A_D}) + (t_{s_D})$$

The access time for the Expansion ROM or for the EBDATA (BCR30) device (t_{ACC}) during write operations can be calculated by subtracting the clock to output delay for the EBUA_EBA[7:0] outputs ($t_{v_A_D}$) and by adding the input to clock setup time for Flash/EPROM inputs (t_{s_D}) from the time defined by ROMTMG.

$$t_{ACC} = \text{ROMTMG} * \text{CLK period} * \text{CLK_FAC} - (t_{v_A_D}) - (t_{s_D})$$

		For an adapter card application, the value used for clock period should be 30 ns to guarantee correct interface timing at the maximum clock frequency of 33 MHz.			is operating in the NO-SRAM mode.
		These bits are read accessible always; write accessible only when the STOP bit is set. ROMTMG is set to the value of 1001b by H_RESET and is not affected by S_RESET or STOP. The default value allows using an Expansion ROM with an access time of 250 ns in a system with a maximum clock frequency of 33 MHz.			Read/Write accessible only when either the STOP or the SPND bit is set. NOUFLO is cleared to 0 after H_RESET or S_RESET and is unaffected by STOP.
11	NOUFLO	No Underflow on Transmit. When the NOUFLO bit is set to 1, the Am79C978A controller will not start transmitting the preamble for a packet until the Transmit Start Point (CSR80, bits 10-11) requirement (except when XMTSP = 3h, Full Packet has no meaning when NOUFLO is set to 1) has been met <i>and</i> the complete packet has been DMA'd into the Am79C978A controller. The complete packet may reside in any combination of the Bus Transmit FIFO, the SRAM, and the MAC Transmit FIFO as long as enough of the packet is in the MAC Transmit FIFO to meet the Transmit Start Point requirement. When the NOUFLO bit is cleared to 0, the Transmit Start Point is the only restriction on when preamble transmission begins for transmit packets.			
		Setting the NOUFLO bit guarantees that the Am79C978A controller will never suffer transmit underflows, because the arbiter that controls transfers to and from the SRAM guarantees a worst case latency on transfers to and from the MAC and Bus Transmit FIFOs such that it will never underflow if the complete packet has been DMA'd into the Am79C978A controller before packet transmission begins.			
		The NOUFLO bit has no effect when the Am79C978A controller	10	RES	Reserved location. Written as zero and read as undefined.
			9	MEMCMD	Memory Command used for burst read accesses to the transmit buffer. When MEMCMD is set to 0, all burst read accesses to the transmit buffer are of the PCI command type Memory Read Line (type 14). When MEMCMD is set to 1, all burst read accesses to the transmit buffer are of the PCI command type Memory Read Multiple (type 12).
					This bit is read accessible always; write accessible only when either the STOP or the SPND bit is set. MEMCMD is cleared by H_RESET and is not affected by S_RESET or STOP.
			8	EXTREQ	Extended Request. This bit controls the deassertion of REQ for a burst transaction. If EXTREQ is set to 0, REQ is deasserted at the beginning of a burst transaction. (The Am79C978A controller never performs more than one burst transaction within a single bus mastership period.) In this mode, the Am79C978A controller relies on the PCI latency timer to get enough bus bandwidth, in case the system arbiter also removes GNT at the beginning of the burst transaction. If EXTREQ is set to 1, REQ stays asserted until the last but one data phase of the burst transaction is done. This mode is useful for systems that implement an arbitration scheme without preemption and require that REQ stays asserted throughout the transaction.
					EXTREQ should not be set to 1 when the Am79C978A controller is used in a PCI bus application.

		<p>This bit is read accessible always, write accessible only when either the STOP or the SPND bit is set. EXTREQ is cleared by H_RESET and is not affected by S_RESET or STOP.</p>	<p>Am79C978A controller can perform burst transfers when reading the initialization block, the descriptor ring entries (when SWSTYLE = 3), and the buffer memory.</p>
7	DWIO	<p>Double Word I/O. When set, this bit indicates that the Am79C978A controller is programmed for DWord I/O (DWIO) mode. When cleared, this bit indicates that the Am79C978A controller is programmed for Word I/O (WIO) mode. This bit affects the I/O Resource Offset map and it affects the defined width of the Am79C978A controller's I/O resources. See the DWIO and WIO sections for more details.</p> <p>The initial value of the DWIO bit is determined by the programming of the EEPROM.</p> <p>The value of DWIO can be altered automatically by the Am79C978A controller. Specifically, the Am79C978A controller will set DWIO if it detects a DWord write access to offset 10h from the Am79C978A controller's I/O base address (corresponding to the RDP resource).</p> <p>Once the DWIO bit has been set to a 1, only a H_RESET or an EEPROM read can reset it to a 0. (Note that the EEPROM read operation will only set DWIO to a 0 if the appropriate bit inside of the EEPROM is set to 0.)</p> <p>This bit is read accessible always. DWIO is read only, write operations have no effect. DWIO is cleared by H_RESET and is not affected S_RESET or by setting the STOP bit.</p>	<p>BREADE should be set to 1 when the Am79C978A controller is used in a PCI bus application to guarantee maximum performance.</p> <p>This bit is read accessible always; write accessible only when either the STOP or the SPND bit is set. BREADE is cleared by H_RESET and is not affected by S_RESET or STOP.</p>
		<p>The initial value of the DWIO bit is determined by the programming of the EEPROM.</p>	<p>Am79C978A controller can perform burst transfers when writing the descriptor ring entries (when SWSTYLE = 3), and the buffer memory.</p>
5	BWRITE	<p>Burst Write Enable. When set, this bit enables burst mode during memory write accesses. When cleared, this bit prevents the device from performing bursting during write accesses. The Am79C978A controller can perform burst transfers when writing the descriptor ring entries (when SWSTYLE = 3), and the buffer memory.</p> <p>BWRITE should be set to 1 when the Am79C978A controller is used in a PCI bus application to guarantee maximum performance.</p> <p>This bit is read accessible always, write accessible only when either the STOP or the SPND bit is set. BWRITE is cleared by H_RESET and is not affected by S_RESET or STOP.</p>	<p>BWRITE should be set to 1 when the Am79C978A controller is used in a PCI bus application to guarantee maximum performance.</p> <p>This bit is read accessible always, write accessible only when either the STOP or the SPND bit is set. BWRITE is cleared by H_RESET and is not affected by S_RESET or STOP.</p>
4-3	PHYSEL[1:0]	<p>PHYSEL[1:0] bits allow for software controlled selection of different operation and test modes. The normal mode of operation is when both bits 0 and 1 are set to 0 to select the Expansion ROM/Flash. Setting bit 0 to 1 and bit 1 to 0 allows snooping of the internal MII-compatible bus to allow External Address Detection Interface (EADI). See Table 38 for details.</p>	<p>PHYSEL[1:0] bits allow for software controlled selection of different operation and test modes. The normal mode of operation is when both bits 0 and 1 are set to 0 to select the Expansion ROM/Flash. Setting bit 0 to 1 and bit 1 to 0 allows snooping of the internal MII-compatible bus to allow External Address Detection Interface (EADI). See Table 38 for details.</p>
6	BREADE	<p>Burst Read Enable. When set, this bit enables burst mode during memory read accesses. When cleared, this bit prevents the device from performing bursting during read accesses. The</p>	

Table 38. PHY Select Programming

PHYSEL [1:0]	Mode
00	Expansion ROM/Flash
01	EADI/Internal MII Snoop
10	Reserved
11	Reserved

These bits are read accessible always, these bits can only be written from the EEPROM unless a write-enable bit, BCR2[13], is set. PHYSEL [1:0] is cleared by H_RESET and is not affected by S_RESET or STOP.

2-0 LINBC Reserved locations. These bits are read accessible always; write accessible only when either the STOP or the SPND bit is set. After H_RESET, the value in these bits will be 001b. The setting of these bits have no effect on any Am79C978A controller's function. LINBC is not affected by S_RESET or STOP.

BCR19: EEPROM Control and Status

Bit	Name	Description
31-16	RES	Reserved locations. Written as zeros and read as undefined.
15	PVALID	<p>EEPROM Valid status bit. This bit is read accessible only. PVALID is read only; write operations have no effect. A value of 1 in this bit indicates that a PREAD operation has occurred, and that (1) there is an EEPROM connected to the Am79C978A controller interface pins and (2) the contents read from the EEPROM have passed the checksum verification operation.</p> <p>A value of 0 in this bit indicates a failure in reading the EEPROM. The checksum for the entire 82 bytes of EEPROM is incorrect or no EEPROM is connected to the interface pins.</p> <p>PVALID is set to 0 during H_RESET and is unaffected by S_RESET or the STOP bit. However, following the H_RESET operation, an automatic read of the</p>

EEPROM will be performed. Just as it is true for the normal PREAD command, at the end of this automatic read operation the PVALID bit may be set to 1. Therefore, H_RESET will set the PVALID bit to 0 at first, but the automatic EEPROM read operation may later set PVALID to a 1.

If PVALID becomes 0 following an EEPROM read operation (either automatically generated after H_RESET, or requested through PREAD), then all EEPROM-programmable BCR locations will be reset to their H_RESET values. The content of the Address PROM locations, however, will not be cleared.

If no EEPROM is present at the EESK, EEDI, and EEDO pins, then all attempted PREAD commands will terminate early and PVALID will *not* be set. This applies to the automatic read of the EEPROM after H_RESET, as well as to host-initiated PREAD commands.

14	PREAD	<p>EEPROM Read command bit. When this bit is set to a 1 by the host, the PVALID bit (BCR19, bit 15) will immediately be reset to a 0, and then the Am79C978A controller will perform a read operation of 82 bytes from the EEPROM through the interface. The EEPROM data that is fetched during the read will be stored in the appropriate internal registers on board the controller. Upon completion of the EEPROM read operation, the Am79C978A controller will assert the PVALID bit. EEPROM contents will be indirectly accessible to the host through read accesses to the Address PROM (offsets 0h through Fh) and through read accesses to other EEPROM programmable registers. Note that read accesses from these locations will not actually access the EEPROM itself, but instead will access the Am79C978A internal copy of the EEPROM contents. Write</p>
----	-------	--

accesses to these locations may change the Am79C978A register contents, but the EEPROM locations will not be affected. EEPROM locations may be accessed directly through BCR19.

At the end of the read operation, the PREAD bit will automatically be reset to a 0 by the Am79C978A controller and PVALID will be set, provided that an EEPROM existed on the interface pins and that the checksum for the entire 68 bytes of EEPROM was correct.

Note that when PREAD is set to a 1, then the Am79C978A controller will no longer respond to any accesses directed toward it, until the PREAD operation has completed successfully. The controller will terminate these accesses with the assertion of $\overline{\text{DEVSEL}}$ and STOP while $\overline{\text{TRDY}}$ is not asserted, signaling to the initiator to disconnect and retry the access at a later time.

If a PREAD command is given to the Am79C978A controller but no EEPROM is attached to the interface pins, the PREAD bit will be cleared to a 0, and the PVALID bit will remain reset with a value of 0. This applies to the automatic read of the EEPROM after H_RESET as well as to host initiated PREAD commands. EEPROM programmable locations on board the Am79C978A controller will be set to their default values by such an aborted PREAD operation. For example, if the aborted PREAD operation immediately followed the H_RESET operation, then the final state of the EEPROM programmable locations will be equal to the H_RESET programming for those locations.

If a PREAD command is given to the Am79C978A controller and the auto-detection pin ($\text{EESK}/\overline{\text{LED1}}$) indicates that no EEPROM is present, then the EEPROM read operation will still be attempted.

Note that at the end of the H_RESET operation, a read of the EEPROM will be performed automatically. This H_RESET-generated EEPROM read function will not proceed if the auto-detection pin ($\text{EESK}/\overline{\text{LED1}}$) indicates that no EEPROM is present.

This bit is read accessible always; write accessible only when either the STOP or the SPND bit is set. PREAD is set to 0 during H_RESET and is unaffected by S_RESET or the STOP bit.

13	EEDET	EEPROM Detect. This bit indicates the sampled value of the $\text{EESK}/\overline{\text{LED1}}$ pin at the end of H_RESET. This value indicates whether or not an EEPROM is present at the EEPROM interface. If this bit is a 1, it indicates that an EEPROM is present. If this bit is a 0, it indicates that an EEPROM is not present.
----	-------	--

This bit is read accessible only. EEDET is read only; write operations have no effect. The value of this bit is determined at the end of the H_RESET operation. It is unaffected by S_RESET or the STOP bit.

Table 39 indicates the possible combinations of EEDET and the existence of an EEPROM and the resulting operations that are possible on the EEPROM interface.

12-5	RES	Reserved locations. Written as zeros; read as undefined.
------	-----	--

4	EEN	EEPROM Port Enable. When this bit is set to a 1, it causes the values of ECS, ESK, and EDI to be driven onto the EECS, EESK, and EEDI pins, respectively. If EEN = 0 and no EEPROM read function is currently active, then EECS will be driven LOW. When EEN = 0 and no EEPROM read function is currently active, EESK and EEDI pins will be driven by the LED registers BCR5 and BCR4, respectively. See Table 40.
---	-----	---

		This bit is read accessible always, write accessible only when either the STOP or the SPND bit is set. EEN is set to 0 by H_RESET and is unaffected by the S_RESET or STOP bit.	edge of the next clock following bit programming.
3	RES	Reserved location. Written as zero and read as undefined.	
2	ECS	EEPROM Chip Select. This bit is used to control the value of the EECS pin of the interface when the EEN bit is set to 1 and the PREAD bit is set to 0. If EEN = 1 and PREAD = 0 and ECS is set to a 1, then the EECS pin will be forced to a HIGH level at the rising	<p>If EEN = 1 and PREAD = 0 and ECS is set to a 0, then the EECS pin will be forced to a LOW level at the rising edge of the next clock following bit programming. ECS has no effect on the output value of the EECS pin unless the PREAD bit is set to 0 and the EEN bit is set to 1.</p> <p>This bit is read accessible always, write accessible only when either the STOP or the SPND bit is set. ECS is set to 0 by H_RESET and is not affected by S_RESET or STOP.</p>

Table 39. EEDET Setting

EEDET Value (BCR19[13])	EEPROM Connected?	Result if PREAD is Set to 1	Result of Automatic EEPROM Read Operation Following H_RESET
0	No	EEPROM read operation is attempted. Entire read sequence will occur, checksum failure will result, PVALID is reset to 0.	First two EESK clock cycles are generated, then EEPROM read operation is aborted and PVALID is reset to 0.
0	Yes	EEPROM read operation is attempted. Entire read sequence will occur, checksum operation will pass, PVALID is set to 1.	First two EESK clock cycles are generated, then EEPROM read operation is aborted and PVALID is reset to 0.
1	No	EEPROM read operation is attempted. Entire read sequence will occur, checksum failure will result, PVALID is reset to 0.	EEPROM read operation is attempted. Entire read sequence will occur, checksum failure will result, PVALID is reset to 0.
1	Yes	EEPROM read operation is attempted. Entire read sequence will occur, checksum operation will pass, PVALID is set to 1.	EEPROM read operation is attempted. Entire read sequence will occur, checksum operation will pass, PVALID is set to 1.

Table 40. Interface Pin Assignment

RST Pin	PREAD or Auto Read in Progress	EEN	EECS	EESK	EEDI
Low	X	X	0	Tri-State	Tri-State
High	1	X	Active	Active	Active
High	0	1	From ECS Bit of BCR19	From ESK Bit of BCR19	From EEDI Bit of BCR19
High	0	0	0	LED1	LED0

1	ESK	<p>EEPROM Serial Clock. This bit and the EDI/EDO bit are used to control host access to the EEPROM. Values programmed to this bit are placed onto the EESK pin at the rising edge of the next clock following bit programming, except when the PREAD bit is set to 1 or the EEN bit is set to 0. If both the ESK bit and the EDI/EDO bit values are changed during one BCR19 write operation, while EEN = 1, then set-up and hold times of the EEDI pin value with respect to the EESK signal edge are not guaranteed.</p> <p>ESK has no effect on the EESK pin unless the PREAD bit is set to 0 and the EEN bit is set to 1.</p> <p>This bit is read accessible always, write accessible only when either the STOP or the SPND bit is set. ESK is reset to 1 by H_RESET and is not affected by S_RESET or STOP.</p>	10	APERREN	<p>Advanced Parity Error Handling Enable. When APERREN is set to 1, the BPE bits (RMD1 and TMD1, bit 23) start having a meaning. BPE will be set in the descriptor associated with the buffer that was accessed when a data parity error occurred. Note that since the advanced parity error handling uses an additional bit in the descriptor, SWSTYLE (bits 7-0 of this register) must be set to 2 or 3 to program the Am79C978A controller to use 32-bit software structures.</p> <p>APERREN does not affect the reporting of address parity errors or data parity errors that occur when the Am79C978A controller is the target of the transfer.</p> <p>Read anytime; write accessible only when either the STOP or the SPND bit is set. APERREN is cleared by H_RESET and is not affected by S_RESET or STOP.</p>
0	EDI/EDO	<p>EEPROM Data In/EEPROM Data Out. Data that is written to this bit will appear on the EEDI output of the interface, except when the PREAD bit is set to 1 or the EEN bit is set to 0. Data that is read from this bit reflects the value of the EEDO input of the interface.</p> <p>EDI/EDO has no effect on the EEDI pin unless the PREAD bit is set to 0 and the EEN bit is set to 1.</p> <p>Read accessible always; write accessible only when either the STOP or the SPND bit is set. EDI/EDO is reset to 0 by H_RESET and is not affected by S_RESET or STOP.</p>	9	RES	<p>Reserved location. Written as zero; read as undefined.</p>
			8	SSIZE32	<p>Software Size 32 bits. When set, this bit indicates that the Am79C978A controller utilizes 32-bit software structures for the initialization block and the transmit and receive descriptor entries. When cleared, this bit indicates that the Am79C978A controller utilizes 16-bit software structures for the initialization block and the transmit and receive descriptor entries. In this mode, the Am79C978A controller is backwards compatible with the Am7990 LANCE and Am79C960 PCnet-ISA controllers.</p> <p>The value of SSIZE32 is determined by the Am79C978A controller according to the setting of the Software Style (SWSTYLE, bits 7-0 of this register).</p> <p>This bit is always read accessible. SSIZE32 is read only; write operations will be ignored. SSIZE32 will be cleared after H_RESET (since SWSTYLE defaults to 0) and is</p>

BCR20: Software Style

This register is an alias of the location CSR58. Accesses to and from this register are equivalent to accesses to CSR58.

Bit	Name	Description
31-11	RES	Reserved locations. Written as zeros and read as undefined.

not affected by S_RESET or STOP.

If SSIZE32 is reset, then bits IADR[31:24] of CSR2 will be used to generate values for the upper 8 bits of the 32-bit address bus during master accesses initiated by the Am79C978A controller. This action is required, since the 16-bit software structures specified by the SSIZE32 = 0 setting will yield only 24 bits of address for Am79C978A controller bus master accesses.

If SSIZE32 is set, then the software structures that are common to the Am79C978A controller and the host system will supply a full 32 bits for each address pointer that is needed by the Am79C978A controller for performing master accesses.

The value of the SSIZE32 bit has no effect on the drive of the upper 8 address bits. The upper 8 address pins are always driven, regardless of the state of the SSIZE32 bit.

Note that the setting of the SSIZE32 bit has no effect on the defined width for I/O resources. I/O resource width is determined by the state of the DWIO bit (BCR18, bit 7).

7-0 SWSTYLE Software Style register. The value in this register determines the style of register and memory resources that shall be used by the Am79C978A controller. The Software Style selection will affect the interpretation of a few bits within the CSR space, the order of the descriptor entries and the width of the descriptors and initialization block entries.

All Am79C978A CSR bits and all descriptor, buffer, and initialization block entries not cited in Table 41 are unaffected by the Software Style selection and are, therefore, always fully functional as specified in the CSR and BCR sections.

Read/Write accessible only when either the STOP or the SPND bit is set. The SWSTYLE register will contain the value 00h following H_RESET and will be unaffected by S_RESET or STOP.

Table 41. Software Styles

SWSTYLE [7:0]	Style Name	SSIZE32	Initialization Block Entries	Descriptor Ring Entries
00h	LANCE/ PCnet-ISA controller	0	16-bit software structures, non-burst or burst access	16-bit software structures, non-burst access only
01h	RES	1	RES	RES
02h	PCnet-PCI controller	1	32-bit software structures, non-burst or burst access	32-bit software structures, non-burst access only
03h	PCnet-PCI controller	1	32-bit software structures, non-burst or burst access	32-bit software structures, non-burst or burst access
All Other	RES	Undefined	Undefined	Undefined

BCR22: PCI Latency Register

Note: Bits 15-0 in this register are programmable through the EEPROM.

Bit	Name	Description
31-16	RES	Reserved locations. Written as zeros and read as undefined.
15-8	MAX_LAT	<p>Maximum Latency. Specifies the maximum arbitration latency the Am79C978A controller can sustain without causing problems to the network activity. The register value specifies the time in units of 1/4 microseconds. MAX_LAT is aliased to the PCI configuration space register MAX_LAT (offset 3Fh). The host will use the value in the register to determine the setting of the Am79C978A Latency Timer register.</p> <p>Read accessible always; write accessible only when either the STOP or the SPND bit is set. MAX_LAT is set to the value of FFh by H_RESET which results in a default maximum latency of 63.75 microseconds. It is recommended to program the value of 18h via EEPROM. MAX_LAT is not affected by S_RESET or STOP.</p>
7-0	MIN_GNT	<p>Minimum Grant. Specifies the minimum length of a burst period the Am79C978A controller needs to keep up with the network activity. The length of the burst period is calculated assuming a clock rate of 33 MHz. The register value specifies the time in units of 1/4 ms. MIN_GNT is aliased to the PCI Configuration Space register MIN_GNT (offset 3Eh). The host will use the value in the register to determine the setting of the Am79C978A Latency Timer register.</p> <p>Read accessible always; write accessible only when either the STOP or the SPND bit is set. MIN_GNT is set to the value of 06h by H_RESET which results in a default minimum grant of</p>

1.5 ms, which is the time it takes to Am79C978A controller to read/write half of the FIFO. (16 DWord transfers in burst mode with one extra wait state per data phase inserted by the target.) Note that the default is only a typical value. It also does not take into account any descriptor accesses. It is recommended to program the value of 18h via EEPROM. MIN_GNT is not affected by S_RESET or STOP.

BCR23: PCI Subsystem Vendor ID Register

Note: Bits 15-0 in this register are programmable through the EEPROM.

Bit	Name	Description
31-0	RES	Reserved locations. Written as zeros and read as undefined.
15-0	SVID	<p>Subsystem Vendor ID. SVID is used together with SID (BCR24, bits 15-0) to uniquely identify the add-in board or subsystem the Am79C978A controller is used in. Subsystem Vendor IDs can be obtained from the PCI SIG. A value of 0 (the default) indicates that the Am79C978A controller does not support subsystem identification. SVID is aliased to the PCI Configuration Space register Subsystem Vendor ID (offset 2Ch).</p> <p>This bit is always read accessible. SVID is read only. Write operations are ignored. SVID is cleared to 0 by H_RESET and is not affected by S_RESET or by setting the STOP bit.</p>

BCR24: PCI Subsystem ID Register

Note: Bits 15-0 in this register are programmable through the EEPROM.

Bit	Name	Description
31-16	RES	Reserved locations. Written as zeros and read as undefined.
15-0	SID	<p>Subsystem ID. SID is used together with SVID (BCR23, bits 15-0) to uniquely identify the add-in board or subsystem the Am79C978A controller is used in.</p>

The value of SID is up to the system vendor. A value of 0 (the default) indicates that the Am79C978A controller does not support subsystem identification. SID is aliased to the PCI configuration space register Subsystem ID (offset 2Eh).

This bit is always read accessible. SID is read only. Write operations are ignored. SID is cleared to 0 by H_RESET and is not affected by S_RESET or by setting the STOP bit.

BCR25: SRAM Size Register

Bit	Name	Description
-----	------	-------------

Note: Bits 7-0 in this register are programmable through the EEPROM.

31-8 RES Reserved locations. Written as zeros and read as undefined.

7-0 SRAM_SIZE SRAM Size. Specifies the upper 8 bits of the 16-bit total size of the SRAM buffer. Each bit in SRAM_SIZE accounts for a 512-byte page. The starting address for the lower 8 bits is assumed to be 00h and the ending address for the lower is assumed to be FFh. Therefore, the maximum address range is the starting address of 0000h to ending address of ((SRAM_SIZE+1) * 256 words) or 17FFh. An SRAM_SIZE value of all zeros specifies that no SRAM will be used and the internal FIFOs will be joined into a contiguous FIFO similar to the PCnet-PCI II controller.

Note: The minimum allowed number of pages is eight for normal network operation. The Am79C978A controller will not operate correctly with less than the eight pages of memory. When the minimum number of pages is used, these pages must be allocated four each for transmit and receive.

CAUTION: Programming SRAM_BND and SRAM_SIZE to the same value will cause

data corruption except in the case where SRAM_SIZE is 0.

This bit is always read accessible; write accessible only when the STOP bit is set. SRAM_SIZE is set to 000000b during H_RESET and is unaffected by S_RESET or STOP.

BCR26: SRAM Boundary Register

Bit	Name	Description
-----	------	-------------

Note: Bits 7-0 in this register are programmable through the EEPROM.

31-8 RES Reserved locations. Written as zeros and read as undefined.

7-0 SRAM_BND SRAM Boundary. Specifies the upper 8 bits of the 16-bit address boundary where the receive buffer begins in the SRAM. The transmit buffer in the SRAM begins at address 0 and ends at the address located just before the address specified by SRAM_BND. Therefore, the receive buffer always begins on a 512 byte boundary. The lower bits are assumed to be zeros. SRAM_BND has no effect in the Low Latency Receive mode.

Note: The minimum allowed number of pages is four. The Am79C978A controller will not operate correctly with less than four pages of memory per queue. See Table 42 for SRAM_BND programming details.

Table 42. SRAM_BND Programming

SRAM Addresses	SRAM_BND [7:0]
Minimum SRAM_BND Address	04h
Maximum SRAM_BND Address	13h

CAUTION: Programming SRAM_BND and SRAM_SIZE to the same value will cause data corruption except in the case where SRAM_SIZE is 0.

Read accessible always; write accessible only when the STOP bit is set. SRAM_BND is set to 00000000b during H_RESET

and is unaffected by S_RESET or STOP.

BCR27: SRAM Interface Control Register

Bit	Name	Description
31-16	RES	Reserved locations. Written as zeros and read as undefined.
15	PTR_TST	Reserved. Reserved for manufacturing tests. Written as zero and read as undefined. <i>Note: Use of this bit will cause data corruption and erroneous operation.</i> This bit is always read/write accessible. PTR_TST is set to 0 by H_RESET and is unaffected by S_RESET and the STOP bit.

14 LOLATRX Low Latency Receive. When the LOLATRX bit is set to 1, the Am79C978A controller will switch to an architecture applicable to cut-through switches. The Am79C978A controller will assert a receive frame DMA after only 16 bytes of the current receive frame has been received regardless of where the RCVFW (CSR80, bits 13-12) are set. The watermark is a fixed value and cannot be changed. The receive FIFOs will be in NO_SRAM mode while all transmit traffic is buffered through the SRAM. This bit is only valid and the low latency receive only enabled when the SRAM_SIZE (BCR25, bits 7-0) bits are non-zero. SRAM_BND (BCR26, bits 7-0) has no meaning when the Am79C978A controller is in the Low Latency mode. See the section on *SRAM Configuration* for more details.

When the LOLATRX bit is set to 0, the Am79C978A controller will return to a normal receive configuration. The runt packet accept bit (RPA, CSR124, bit 3) must be set when LOLATRX is set.

CAUTION: To provide data integrity when switching into and out of the low latency mode, DO

NOT SET the FASTSPNDE (CSR7, bit 15) bit when setting the SPND bit. Receive frames WILL be overwritten and the Am79C978A controller may give erratic behavior when it is enable again. The minimum allowed number of pages is four. The Am79C978A controller will not operate correctly in the LOLATRX mode with less than four pages of memory.

Read/Write accessible only when the STOP bit is set. LOLATRX is cleared to 0 after H_RESET or S_RESET and is unaffected by STOP.

13-6 RES Reserved locations. Written as zeros and read as undefined.

5-3 EBCS Expansion Bus Clock Source. These bits are used to select the source of the fundamental clock to drive the SRAM and Expansion ROM access cycles. Table 43 shows the selected clock source for the various values of EBCS. Note that the actual frequency that the Expansion Bus access cycles run at is a function of both the EBCS and CLK_FAC (BCR27, bits 2-0) bit field settings. When EBCS is set to either the PCI clock or the Time Base clock, no external clock source is required as the clocks are routed internally and the EBCLK pin should be pulled to VDD through a resistor.

Table 43. EBCS Values

EBCS	Expansion Bus Clock Source
000	CLK pin (PCI Clock)
001	Time Base Clock
010	EBCLK pin
011	Reserved
1XX	Reserved

Read accessible always; write accessible only when the STOP bit is set. EBCS is set to 000b (PCI clock selected) during H_RESET and is unaffected by S_RESET or the STOP bit.

Note: The clock frequency driving the Expansion Bus access cycles that results from the settings of the EBCS and CLK FAC bits must not exceed 33 MHz at any time. When EBCS is set to either the PCI clock or the Time Base clock, no external clock source is required because the clocks are routed internally and the EBCLK pin should be pulled to VDD through a resistor.

CAUTION: Care should be exercised when choosing the PCI clock pin because of the nature of the PCI clock signal. The PCI specification states that the PCI clock can be stopped. If that can occur while it is being used for the Expansion Bus clock data, corruption will result.

CAUTION: The Time Base Clock will not support 100 Mbps operation and should only be selected in 10 Mbps-only configurations.

CAUTION: The external clock source used to drive the EBCLK pin must be a continuous clock source at all times.

2-0 CLK_FAC Clock Factor. These bits are used to select whether the clock selected by EBCS is used directly or if it is divided down to give a slower clock for running the Expansion Bus access cycles. The possible factors are given in Table 44.

Table 44. CLK_FAC Values

CLK_FAC	Clock Factor
000	1
001	1/2 (divide by 2)
010	Reserved
011	1/4 (divide by 4)
1XX	Reserved

Read accessible always; write accessible only when the STOP bit is set. CLK_FAC is set to 000b during H_RESET and is unaffected by S_RESET or STOP.

BCR28: Expansion Bus Port Address Lower (Used for Flash/EPROM and SRAM Accesses)

Bit	Name	Description
31-16	RES	Reserved locations. Written as zeros and read as undefined.
15-0	EPADDRL	Expansion Port Address Lower. This address is used to provide addresses for the Flash and SRAM port accesses.

SRAM accesses are started when a read or write is performed on BCR30 and the FLASH (BCR 29, bit 15) is set to 0. During SRAM accesses only bits in the EPADDRL are valid. Since all SRAM accesses are word oriented only, EPADDRL[0] is the least significant word address bit. On any byte write accesses to the SRAM, the user will have to follow the read-modify-write scheme. On any byte read accesses to the SRAM, the user will have to choose which byte is needed from the complete word returned in BCR30.

Flash accesses are started when a read or write is performed on BCR30 and the FLASH (BCR 29, bit 15) is set to 1. During Flash accesses all bits in EPADDR are valid.

Read accessible always; write accessible only when the STOP is set or when SRAM SIZE (BCR25, bits 7-0) is 0. EPADDRL is undefined after H_RESET and is unaffected by S_RESET or STOP.

BCR29: Expansion Port Address Upper (Used for Flash/EPROM Accesses)

Bit	Name	Description
31-16	RES	Reserved locations. Written as zeros and read as undefined.
15	FLASH	Flash Access. When the FLASH bit is set to 1, the Expansion Bus access will be a Flash cycle. When FLASH is set to 0, the Expansion Bus access will be a

SRAM cycle. For a complete description, see the section on *Expansion Bus Accesses*. This bit is only applicable to reads or writes to EBDATA (BCR30). It does not affect Expansion ROM accesses from the PCI system bus.

This bit is always read accessible; write accessible only when the STOP bit is set. FLASH is 0 after H_RESET and is unaffected by S_RESET or the STOP bit.

14 LAAINC Lower Address Auto Increment. When the LAAINC bit is set to 1, the Expansion Port Lower Address will automatically increment by one after a read or write access to EBDATA (BCR30). When EBADDRL reaches FFFFh and LAAINC is set to 1, the Expansion Port Lower Address (EPADDRL) will roll over to 0000h. When the LAAINC bit is set to 0, the Expansion Port Lower Address will not be affected in any way after an access to EBDATA (BCR30) and must be programmed.

This bit is always read accessible; write accessible only when the STOP bit is set. LAINC is 0 after H_RESET and is unaffected by S_RESET or the STOP bit.

13-4 RES Reserved locations. Written as zeros and read as undefined.

3-0 EPADDRU Expansion Port Address Upper. This upper portion of the Expansion Bus address is used to provide addresses for Flash/EPROM port accesses.

This bit is always read accessible; write accessible only when the STOP bit is set or when SRAM SIZE (BCR25, bits 7-0) is 0. EPADDRU is undefined after H_RESET and is unaffected by S_RESET or the STOP bit.

15-0 EBDATA

Expansion Bus Data Port. EBDATA is the data port for operations on the Expansion Port accesses involving SRAM and Flash accesses. The type of access is set by the FLASH bit (BCR 29, bit 15). When the FLASH bit is set to 1, the Expansion Bus access will follow the Flash access timing. When the FLASH bit is set to 0, the Expansion Bus access will follow the SRAM access timing.

Note: It is important to set the FLASH bit and load Expansion Port Address EPADDR (BCR28, BCR29) with the required address before attempting read or write to the Expansion Bus data port. The Flash and SRAM accesses use different address phases. Incorrect configuration will result in a possible corruption of data.

Flash read cycles are performed when BCR30 is read and the FLASH bit (BCR29, bit 15) is set to 1. Upon completion of the read cycle, the 8-bit result for Flash access is stored in EBDATA[7:0], EBDATA[15:8] is undefined. Flash write cycles are performed when BCR30 is written and the FLASH bit (BCR29, bit 15) is set to 1. EBDATA[7:0] only is valid for write cycles.

SRAM read cycles are performed when BCR30 is read and the FLASH bit (BCR29, bit 15) is set to 0. Upon completion of the read cycle, the 16-bit result for SRAM access is stored in EBDATA. Write cycles to the SRAM are invoked when BCR30 is written and the FLASH bit (BCR29, bit 15) is set to 0. Byte writes to the SRAM must use a read-modify-write scheme since the word is always valid for SRAM write or read accesses.

This bit is read and write accessible only when the STOP is set or when SRAM SIZE (BCR25, bits 7-0) is 0. EBDATA is undefined after H_RESET and is unaffected by S_RESET and the STOP bit.

BCR30: Expansion Bus Data Port Register

Bit	Name	Description
31-16	RES	Reserved locations. Written as zeros and read as undefined.

BCR31: Software Timer Register

14 MIIPD

Bit	Name	Description
31-16	RES	Reserved locations. Written as zeros and read as undefined.
15-0	STVAL	<p>Software Timer Value. STVAL controls the maximum time for the Software Timer to count before generating the STINT (CSR7, bit 11) interrupt. The Software Timer is a free-running timer that is started upon the first write to STVAL. After the first write, the Software Timer will continually count and set the STINT interrupt at the STVAL period.</p> <p>The STVAL value is interpreted as an unsigned number with a resolution of 256 Time Base Clock periods. For instance, a value of 122 ms would be programmed with a value of 9531 (253Bh) if the Time Base Clock is running at 20 MHz. A value of 0 is undefined and will result in erratic behavior.</p> <p>Read and write accessible always. STVAL is set to FFFFh after H_RESET and is unaffected by S_RESET and the STOP bit.</p>

MII PHY Detect (is used for manufacturing tests). MIIPD reflects the quiescent state of the MDIO pin. MIIPD is continuously updated whenever there is no management operation in progress on the MII interface. When a management operation begins on the interface, the state of MIIPD is preserved until the operation ends, when the quiescent state is again monitored and continuously updates the MIIPD bit. When the MDIO pin is at a quiescent LOW state, MIIPD is cleared to 0. When the MDIO pin is at a quiescent HIGH state, MIIPD is set to 1. MIIPD is used by the automatic port selection logic to select the MII port. When the Auto Select bit (ASEL, BCR2, bit 1) is a 1 and the MIIPD bit is a 1, the MII port is selected. Any transition on the MIIPD bit will set the MIIPDTI bit in CSR7, bit 3.

Read accessible always. MIIPD is read only. Write operations are ignored and should not be performed.

13-12 FMDC

Fast Management Data Clock (is used for manufacturing tests). When FMDC is set to 2h the MII Management Data Clock will run at 10 MHz max. The Management Data Clock will no longer be IEEE 802.3u-compliant and setting this bit should be used with care. The accompanying external PHY must also be able to accept management frames at the new clock rate. When FMDC is set to 1h, the MII Management Data Clock will run at 5 MHz max. The Management Data Clock will no longer be IEEE 802.3u-compliant and setting this bit should be used with care. The accompanying external PHY must also be able to accept management frames at the new clock rate. When FMDC is set to 0h, the MII Management Data Clock will run at 2.5 MHz max and will be fully

BCR32: PHY Control and Status Register

Note: Bits 15-0 in this register are programmable through the EEPROM.

Bit	Name	Description
31-16	RES	Reserved locations. Written as zeros and read as undefined.
15	ANTST	<p>Reserved for manufacturing tests. Written as 0 and read as undefined.</p> <p>Note: Use of this bit will cause data corruption and erroneous operation.</p> <p>This bit is always read/write accessible. ANTST is set to 0 by H_RESET and is unaffected by S_RESET and the STOP bit.</p>

compliant to IEEE 802.3u standards. See Table 45.

Table 45. FMDC Values

FMDC	Fast Management Data Clock
00	2.5 MHz max
01	5 MHz max
10	10 MHz max
11	Reserved

This bit is always read/write accessible. FMDC is set to 0 during H_RESET, and is unaffected by S_RESET and the STOP bit

11 APEP Auto-Poll PHY. When APEP is set to 1 the Am79C978A controller will poll the status register in the PHY. This feature allows the software driver or upper layers to see any changes in the status of the PHY. An interrupt when enabled is generated when the contents of the new status is different from the previous status.

This bit is always read/write accessible. APEP is set to 0 during H_RESET and is unaffected by S_RESET and the STOP bit.

10-8 APDW Auto-Poll Dwell Time. APDW determines the dwell time between PHY Management Frame accesses when Auto-Poll is turned on. See Table 46.

Table 46. APDW Values

APDW	Auto-Poll™ Dwell Time
000	Continuous (26 μs @ 2.5 MHz)
001	Every 128 MDC cycles (103 μs @ 2.5 MHz)
010	Every 256 MDC cycles (206 μs @ 2.5 MHz)
011	Every 512 MDC cycles (410 μs @ 2.5 MHz)
100	Every 1024 MDC cycles (819 μs @ 2.5 MHz)
101	Every 2048 MDC cycles (1640 μs @ 2.5 MHz)
110-111	Reserved

This bit is always read/write accessible. APDW is set to 100h after H_RESET and is unaffected by S_RESET and the STOP bit.

7 DANAS Disable Auto-Negotiation Auto Setup. When DANAS is set, the Am79C978A controller after a H_RESET or

S_RESET will remain dormant and not automatically startup the Auto-Negotiation section or the enhanced automatic port selection section. Instead, the Am79C978A controller will wait for the software driver to setup the Auto-Negotiation portions of the device. The PHY Address and Data programming in BCR33 and BCR34 is still valid. The Am79C978A controller will not generate any management frames unless Auto-Poll is enabled.

This bit is always read/write accessible. DANAS is set to 0 by H_RESET and is unaffected by S_RESET and the STOP bit.

6 XPHYRST PHY Reset. When XPHYRST is set, the Am79C978A controller after an H_RESET or S_RESET will issue management frames that will reset the PHY. This bit is needed when there is no way to guarantee the state of the external PHY. This bit must be reprogrammed after every H_RESET.

This bit is always read/write accessible. XPHYRST is set to 0 by H_RESET and is unaffected by S_RESET and the STOP bit. XPHYRST is only valid when the internal Network Port Manager is scanning for a network port.

5 XPHYANE PHY Auto-Negotiation Enable. This bit will force the PHY into enabling Auto-Negotiation. When set to 0 the Am79C978A controller will send a management frame disabling Auto-Negotiation.

This bit is always read/write accessible. XPHYANE is set to 0 by H_RESET and is unaffected by S_RESET and the STOP bit. XPHYANE is only valid when the internal Network Port Manager is scanning for a network port.

4 XPHYFD PHY Full Duplex. When set, this bit will force the PHY into full duplex when Auto-Negotiation is not enabled.

		This bit is always read/write accessible. XPHYFD is set to 0 by H_RESET, and is unaffected by S_RESET and the STOP bit.
3	XPHYSP	PHY Speed. When set, this bit will force the PHY into 100 Mbps mode when Auto-Negotiation is not enabled.
		This bit is always read/write accessible. XPHYSP is set to 0 by H_RESET, and is unaffected by S_RESET and the STOP bit.
2	RES	Reserved location. Written as zero and read as undefined.
1	MIILP	Media Independent Interface Internal Loopback. When set, this bit will cause the internal portion of the MII data port to loopback on itself. The interface is mapped in the following way. The TXD[3:0] nibble data path is looped back onto the RXD[3:0] nibble data path. TX_CLK is looped back as RX_CLK. TX_EN is looped back as RX_DV. CRS is correctly OR'd with TX_EN and RX_DV and always encompasses the transmit frame. TX_ER is looped back as RX_ER. However, TX_ER will not get asserted by the Am79C978A controller to signal an error. The TX_ER function is reserved for future use.
		This bit is always read/write accessible. MIILP is set to 0 by H_RESET and is unaffected by S_RESET and the STOP bit.
0	RES	Reserved location. Written as zero and read as undefined.

BCR33: PHY Address Register

Bit	Name	Description
31-16	RES	Reserved locations. Written as zeros and read as undefined.
15	SHADOW	If the user wishes to update the contents of the BCR33 shadow register, setting the MSB of the value written into BCR33 (bit 15) will enable the

9-5	PHYAD	Management Frame PHY Address. PHYAD contains the 5-bit PHY Address field that is used in the management frame that gets clocked out via the MII management port pins (MDC and MDIO) whenever a read or write transaction occurs to BCR34. The PHY address 1Fh is not valid.
		The Network Port Manager copies the PHYAD after the Am79C978A controller reads the EEPROM and uses it to communicate with the external PHY. The PHY address must be programmed into the EEPROM prior to starting the Am79C978A controller.
		These bits are always read/write accessible. PHYAD is undefined after H_RESET and is unaffected by S_RESET and the STOP bit.
4-0	REGAD	Management Frame Register Address. REGAD contains the 5-bit Register Address field that is used in the management frame that gets clocked out via the internal MII management interface whenever a read or write transaction occurs to BCR34.
		These bits are always read/write accessible. REGAD is undefined after H_RESET and is unaffected by S_RESET and the STOP bit.

BCR34: PHY Management Data Register

Bit	Name	Description
31-16	RES	Reserved locations. Written as zeros and read as undefined.
15-0	MIIMD	MII Management Data. MIIMD is the data port for operations on the MII management interface (MDIO and MDC). The Am79C978A controller builds management frames using the PHYAD and REGAD values from BCR33. The operation code used in each frame is based upon whether a read or

write operation has been performed to BCR34. Read cycles on the MII management interface are invoked when BCR34 is read. Upon completion of the read cycle, the 16-bit result of the read operation is stored in MIIMD. Write cycles on the MII management interface are invoked when BCR34 is written. The value written to MIIMD is the value used in the data field of the management write frame.

These bits are always read/write accessible. MIIMD is undefined after H_RESET and is unaffected by S_RESET and the STOP bit.

BCR35: PCI Vendor ID Register

Note: Bits 15-0 in this register are programmable through the EEPROM.

Bit	Name	Description
31-16	RES	Reserved locations. Written as zeros and read as undefined.
15-0	VID	Vendor ID. The PCI Vendor ID register is a 16-bit register that identifies the manufacturer of the Am79C978A controller. AMD's Vendor ID is 1022h. Note that this Vendor ID is not the same as the Manufacturer ID in CSR88 and CSR89. The Vendor ID is assigned by the PCI Special Interest Group. The Vendor ID is not normally programmable, but the Am79C978A controller allows this due to legacy operating systems that do not look at the PCI Subsystem Vendor ID and the Vendor ID to uniquely identify the add-in board or subsystem that the Am79C978A controller is used in. Note: If the operating system or the network operating system supports PCI Subsystem Vendor ID and Subsystem ID, use those to identify the add-in board or subsystem and program the VID with the default value of 1022h.

VID is aliased to the PCI configuration space register Vendor ID (offset 00h).

Read accessible always. VID is read only. Write operations are ignored. VID is set to 1022h by H_RESET and is not affected by S_RESET or by setting the STOP bit.

BCR36: PCI Power Management Capabilities (PMC) Alias Register

Note: This register is an alias of the PMC register located at offset 42h of the PCI Configuration Space. Since PMC register is read only, BCR36 provides a means of programming it through the EEPROM. The contents of this register are copied into the PMC register. For the definition of the bits in this register, refer to the PMC register definition. Bits 15-0 in this register are programmable through the EEPROM. Read accessible always. Read only. Cleared by H_RESET and is not affected by S_RESET or setting the STOP bit.

BCR37: PCI DATA Register 0 (DATA0) Alias Register

Note: This register is an alias of the DATA register and also of the DATA_SCALE field of the PMCSR register. Since these two are read only, BCR37 provides a means of programming them indirectly. The contents of this register are copied into the corresponding fields pointed with the DATA_SEL field set to zero. Bits 15-0 in this register are programmable through the EEPROM.

Bit	Name	Description
15-10	RES	Reserved locations. Written as zeros and read as undefined.
9-8	D0_SCALE	These bits correspond to the DATA_SCALE field of the PMCSR (offset Register 44 of the PCI configuration space, bits 14-13). Refer to the description of DATA_SCALE for the meaning of this field. Read accessible always. D0_SCALE is read only. Cleared by H_RESET and is not affected by S_RESET or setting the STOP bit.
7-0	DATA0	These bits correspond to the PCI DATA register (offset Register 47 of the PCI configuration space, bits 7-0). Refer to the description of DATA register for the meaning of this field.

This bit is always read accessible. DATA0 is read only. Cleared by H_RESET and is not affected by S_RESET or setting the STOP bit.

BCR38: PCI DATA Register 1 (DATA1) Alias Register

Note: This register is an alias of the DATA register and also of the DATA_SCALE field of the PMCSR register. Since these two are read only, BCR38 provides a means of programming them through the EEPROM. The contents of this register are copied into the corresponding fields pointed with the DATA_SEL field set to one. Bits 15-0 in this register are programmable through the EEPROM.

Bit	Name	Description
15-10	RES	Reserved locations. Written as zeros and read as undefined.
9-8	D1_SCALE	These bits correspond to the DATA_SCALE field of the PMCSR (offset Register 44 of the PCI configuration space, bits 14-13). Refer to the description of DATA_SCALE for the meaning of this field. These bits are always read accessible. D1_SCALE is read only. Cleared by H_RESET and is not affected by S_RESET or setting the STOP bit.
7-0	DATA1	These bits correspond to the PCI DATA register (offset Register 47 of the PCI configuration space, bits 7-0). Refer to the description of DATA register for the meaning of this field. These bits are always read accessible. DATA1 is read only. Cleared by H_RESET and is not affected by S_RESET or setting the STOP bit.

BCR39: PCI DATA Register 2 (DATA2) Alias Register

Note: This register is an alias of the DATA register and also of the DATA_SCALE field of the PMCSR register. Since these two are read only, BCR39 provides a means of programming them through the EEPROM. The contents of this register are copied into the corresponding fields pointed with the DATA_SEL field set to two. Bits 15-0 in this register are programmable through the EEPROM.

Bit	Name	Description
15-10	RES	Reserved locations. Written as zeros and read as undefined.
9-8	D2_SCALE	These bits correspond to the DATA_SCALE field of the PMCSR (offset Register 44 of the PCI configuration space, bits 14-13). Refer to the description of DATA_SCALE for the meaning of this field. These bits are always read accessible. D2_SCALE is read only. Cleared by H_RESET and is not affected by S_RESET or setting the STOP bit.
7-0	DATA2	These bits correspond to the PCI DATA register (offset Register 47 of the PCI configuration space, bits 7-0). Refer to the description of DATA register for the meaning of this field. These bits are always read accessible. DATA2 is read only. Cleared by H_RESET and is not affected by S_RESET or setting the STOP bit.

BCR40: PCI DATA Register 3 (DATA3) Alias Register

Note: This register is an alias of the DATA register and also of the DATA_SCALE field of the PCMCR register. Since these two are read only, BCR40 provides a means of programming them through the EEPROM. The contents of this register are copied into the corresponding fields pointed with the DATA_SEL field set to three. Bits 15-0 in this register are programmable through the EEPROM.

Bit	Name	Description
15-10	RES	Reserved locations. Written as zeros and read as undefined.
9-8	D3_SCALE	These bits correspond to the DATA_SCALE field of the PMCSR (offset Register 44 of the PCI configuration space, bits 14-13). Refer to the description of DATA_SCALE for the meaning of this field. These bits are always read accessible. D3_SCALE is read only.

Cleared by H_RESET and is not affected by S_RESET or setting the STOP bit.

7-0 DATA3 These bits correspond to the PCI DATA register (offset Register 47 of the PCI configuration space, bits 7-0). Refer to the description of DATA register for the meaning of this field.

These bits are always read accessible. DATA3 is read only. Cleared by H_RESET and is not affected by S_RESET or setting the STOP bit.

BCR41: PCI DATA Register 4 (DATA4) Alias Register

Note: This register is an alias of the DATA register and also of the DATA_SCALE field of the PCMCR register. Since these two are read only, BCR41 provides a means of programming them through the EEPROM. The contents of this register are copied into the corresponding fields pointed with the DATA_SEL field set to four. Bits 15-0 in this register are programmable through the EEPROM.

Bit	Name	Description
15-10	RES	Reserved locations. Written as zeros and read as undefined.
9-8	D4_SCALE	These bits correspond to the DATA_SCALE field of the PMCSR (offset register 44 of the PCI configuration space, bits 14-13). Refer to the description of DATA_SCALE for the meaning of this field. Read accessible always. D4_SCALE is read only. Cleared by H_RESET and is not affected by S_RESET or setting the STOP bit.
7-0	DATA4	These bits correspond to the PCI DATA register (offset Register 47 of the PCI configuration space, bits 7-0). Refer to the description of DATA register for the meaning of this field. Read accessible always. DATA4 is read only. Cleared by H_RESET and is not affected by S_RESET or setting the STOP bit.

BCR42: PCI DATA Register 5 (DATA5) Alias Register

Note: This register is an alias of the DATA register and also of the DATA_SCALE field of the PCMCR register. Since these two are read only, BCR42 provides a means of programming them through the EEPROM. The contents of this register are copied into the corresponding fields pointed with the DATA_SEL field set to five. Bits 15-0 in this register are programmable through the EEPROM.

Bit	Name	Description
15-10	RES	Reserved locations. Written as zeros and read as undefined.
9-8	D5_SCALE	These bits correspond to the DATA_SCALE field of the PMCSR (offset Register 44 of the PCI configuration space, bits 14-13). Refer to the description of DATA_SCALE for the meaning of this field. These bits are always read accessible. D5_SCALE is read only. Cleared by H_RESET and is not affected by S_RESET or setting the STOP bit.
7-0	DATA5	These bits correspond to the PCI DATA register (offset Register 47 of the PCI configuration space, bits 7-0). Refer to the description of DATA register for the meaning of this field. These bits are always read accessible. DATA5 is read only. Cleared by H_RESET and is not affected by S_RESET or setting the STOP bit.

BCR43: PCI DATA Register 6 (DATA6) Alias Register

Note: This register is an alias of the DATA register and also of the DATA_SCALE field of the PCMCR register. Since these two are read only, BCR43 provides a means of programming them through the EEPROM. The contents of this register are copied into the corresponding fields pointed with the DATA_SEL field set to six. Bits 15-0 in this register are programmable through the EEPROM.

Bit	Name	Description
15-10	RES	Reserved locations. Written as zeros and read as undefined.

9-8	D6_SCALE	<p>These bits correspond to the DATA_SCALE field of the PMCSR (offset Register 44 of the PCI configuration space, bits 14-13). Refer to the description of DATA_SCALE for the meaning of this field.</p> <p>These bits are always read accessible. D6_SCALE is read only. Cleared by H_RESET and is not affected by S_RESET or setting the STOP bit</p>	<p>of DATA register for the meaning of this field.</p> <p>These bits are always read accessible. DATA7 is read only. Cleared by H_RESET and is not affected by S_RESET or setting the STOP bit.</p>
7-0	DATA6	<p>These bits correspond to the PCI DATA register (offset Register 47 of the PCI configuration space, bits 7-0). Refer to the description of DATA register for the meaning of this field.</p> <p>These bits are always read accessible. DATA6 is read only. Cleared by H_RESET and is not affected by S_RESET or setting the STOP bit.</p>	

BCR44: PCI DATA Register 7 (DATA7) Alias Register

Note: This register is an alias of the DATA register and also of the DATA_SCALE field of the PMCSR register. Since these two are read only, BCR44 provides a means of programming them through the EEPROM. The contents of this register are copied into the corresponding fields pointed with the DATA_SEL field set to seven. Bits 15-0 in this register are programmable through the EEPROM.

Bit	Name	Description
15-10	RES	Reserved locations. Written as zeros and read as undefined.
9-8	D7_SCALE	<p>These bits correspond to the DATA_SCALE field of the PMCSR (offset Register 44 of the PCI configuration space, bits 14-13). Refer to the description of DATA_SCALE for the meaning of this field.</p> <p>These bits are always read accessible. D7_SCALE is read only. Cleared by H_RESET and is not affected by S_RESET or setting the STOP bit.</p>
7-0	DATA7	These bits correspond to the PCI DATA register (offset register 47 of the PCI configuration space, bits 7-0). Refer to the description

BCR45: OnNow Pattern Matching Register 1

Note: This register is used to control and indirectly access the Pattern Match RAM (PMR). When BCR45 is written and the PMAT_MODE bit (bit 7) is 1, Pattern Match logic is enabled. No bus accesses into PMR are possible, and BCR46, BCR47, and all other bits in BCR45 are ignored. When PMAT_MODE is set, a read of BCR45, BCR46, or BCR47 returns all undefined bits except for PMAT_MODE.

When BCR45 is written and the PMAT_MODE bit is 0, the Pattern Match logic is disabled and accesses to the PMR are possible. Bits 6-0 of BCR45 specify the address of the PMR word to be accessed. Following the write to BCR45, the PMR word may be read by reading BCR45, BCR46 and BCR47 in any order. To write to PMR word, the write to BCR45 must be followed by a write to BCR46 and a write to BCR47 in that order to complete the operation. The RAM will not actually be written until the write to BCR47 is complete. The write to BCR47 causes all 5 bytes (four bytes of BCR46-47 and the upper byte of the BCR45) to be written to whatever PMR word is addressed by bits 6:0 of BCR45.

Bit	Name	Description
31-16	RES	Reserved locations. Written as zeros and read as undefined.
15-8	PMR_B0	Pattern Match RAM Byte 0. This byte is written into or read from Byte 0 of the Pattern Match RAM.
		These bits are read and write accessible always. PMR_B0 is undefined after H_RESET, and is unaffected by S_RESET and the STOP bit.
7	PMAT_MODE	Pattern Match Mode. Writing a 1 to this bit will enable Pattern Match Mode and should only be done after the Pattern Match RAM has been programmed.
		These bits are read and write accessible always. PMAT_MODE is reset to 0 after H_RESET, and is unaffected by S_RESET and the STOP bit.

6-0 PMR_ADDR Pattern Match Ram Address. These bits are the Pattern Match Ram address to be written to or read from.

These bits are read and write accessible always. PMR_ADDR is reset to 0 after H_RESET, and is unaffected by S_RESET and the STOP bit.

BCR46: OnNow Pattern Matching Register 2

Note: This register is used to control and indirectly access the Pattern Match RAM (PMR). When BCR45 is written and the PMAT_MODE bit (bit 7) is 1, Pattern Match logic is enabled. No bus accesses into PMR are possible, and BCR46, BCR47, and all other bits in BCR45 are ignored. When PMAT_MODE is set, a read of BCR45, BCR46, or BCR47 returns all undefined bits except for PMAT_MODE.

When BCR45 is written and the PMAT_MODE bit is 0, the Pattern Match logic is disabled and accesses to the PMR are possible. Bits 6-0 of BCR45 specify the address of the PMR word to be accessed. Following the write to BCR45, the PMR word may be read by reading BCR45, BCR46 and BCR47 in any order. To write to PMR word, the write to BCR45 must be followed by a write to BCR46 and a write to BCR47 in that order to complete the operation. The RAM will not actually be written until the write to BCR47 is complete. The write to BCR47 causes all 5 bytes (four bytes of BCR46-47 and the upper byte of the BCR45) to be written to whatever PMR word is addressed by bits 6:0 of BCR45.

Bit	Name	Description
31-16	RES	Reserved locations. Written as zeros and read as undefined.
15-8	PMR_B2	Pattern Match RAM Byte 2. This byte is written into or read from Byte 2 of the Pattern Match RAM. These bits are read and write accessible always. PMR_B2 is undefined after H_RESET, and is unaffected by S_RESET and the STOP bit.
7-0	PMR_B1	Pattern Match RAM Byte 1. This byte is written into or read from Byte 1 of Pattern Match RAM. These bits are read and write accessible always. PMR_B1 is undefined after H_RESET, and is unaffected by S_RESET and the STOP bit.

BCR47: OnNow Pattern Matching Register 3

Note: This register is used to control and indirectly access the Pattern Match RAM (PMR). When BCR45 is written and the PMAT_MODE bit (bit 7) is 1, Pattern Match logic is enabled. No bus accesses into PMR are possible, and BCR46, BCR47, and all other bits in BCR45 are ignored. When PMAT_MODE is set, a read of BCR45, BCR46, or BCR47 returns all undefined bits except for PMAT_MODE.

When BCR45 is written and the PMAT_MODE bit is 0, the Pattern Match logic is disabled and accesses to the PMR are possible. Bits 6-0 of BCR45 specify the address of the PMR word to be accessed. Following the write to BCR45, the PMR word may be read by reading BCR45, BCR46 and BCR47 in any order. To write to PMR word, the write to BCR45 must be followed by a write to BCR46 and a write to BCR47 in that order to complete the operation. The RAM will not actually be written until the write to BCR47 is complete. The write to BCR47 causes all 5 bytes (four bytes of BCR46-47 and the upper byte of the BCR45) to be written to whatever PMR word is addressed by bits 6:0 of BCR45.

When PMAT_MODE is 0, the contents of the word addressed by bits 6:0 of BCR45 can be read by reading BCR45-47 in any order.

Bit	Name	Description
31-16	RES	Reserved locations. Written as zeros and read as undefined.
15-8	PMR_B4	Pattern Match RAM Byte 4. This byte is written into or read from Byte 4 of Pattern Match RAM. These bits are read and write accessible always. PMR_B4 is undefined after H_RESET, and is unaffected by S_RESET and the STOP bit.
7-0	PMR_B3	Pattern Match RAM Byte 3. This byte is written into or read from Byte 3 of Pattern Match RAM. These bits are read and write accessible always. PMR_B3 is undefined after H_RESET, and is unaffected by S_RESET and the STOP bit.

BCR48: LED4 Status

This register defines the functionality of LED4. LED4 will default to indicating the selected SPEED with Pulse stretching enabled (default = 0082h).

BCR48 controls the function(s) that the LED4 pin displays. Multiple functions can be simultaneously en-

abled on this LED pin. The LED display will indicate the logical OR of the enabled functions.

Note: When LEDPE (BCR2, bit 12) is set to 1, programming of the LED2 Status register is enabled. When LEDPE is cleared to 0, programming of the LED2 register is disabled. Writes to those registers will be ignored.

Note: Bits 15-0 in this register are programmable through the EEPROM PREAD operation.

Bit	Name	Description	Bit	Name	Description
31-16	RES	Reserved locations. Written as zeros and read as undefined.	13	LEDDIS	LED Disable. This bit is used to disable the LED output. When LEDDIS has the value 1, then the LED output will always be disabled. When LEDDIS has the value 0, then the LED output value will be governed by the LEDOUT and LEDPOL values.
15	LEDOUT	This bit indicates the current (non-stretched) value of the LED output pin. A value of 1 in this bit indicates that the OR of the enabled signals is true. The logical value of the LEDOUT status signal is determined by the settings of the individual Status Enable bits of the LED register (bits 8 and 6-0). Read accessible always. This bit is read only; writes have no effect. LEDOUT is unaffected by H_RESET, S_RESET, or STOP.	12	100E	100 Mbps Enable. When this bit is set to 1, a value of 1 is passed to the LEDOUT bit in this register when the Am79C978A controller is operating in 100 Mbps mode. This bit is always read/write accessible. LEDDIS is cleared by H_RESET and is not affected by S_RESET or setting the STOP bit.
14	LEDPOL	LED Polarity. When this bit has the value 0, then the LED pin will be driven to a LOW level whenever the OR of the enabled signals is true, and the LED pin will be disabled and allowed to float high whenever the OR of the enabled signals is false (i.e., the LED output will be an Open Drain output and the output value will be the inverse of the LEDOUT status bit). When this bit has the value 1, then the LED pin will be driven to a HIGH level whenever the OR of the enabled signals is true, and the LED pin will be driven to a LOW level whenever the OR of the enabled signals is false (i.e., the LED output will be a Totem Pole output and the output value will be the same polarity as the LEDOUT status bit).	11-10	RES	Reserved locations. Written and read as zeros.
			9	MPSE	Magic Packet Status Enable. When this bit is set to 1, a value of 1 is passed to the LEDOUT bit in this register when Magic Packet frame mode is enabled and a Magic Packet frame is detected on the network. This bit is always read/write accessible. MPSE is cleared by H_RESET and is not affected by S_RESET or setting the STOP bit.
			8	FDLSE	Full-Duplex Link Status Enable. Indicates the Full-Duplex Link Test Status. When this bit is set, a value of 1 is passed to the LEDOUT signal when the

		Am79C978A controller is functioning in a Link Pass state and full-duplex operation is enabled. When the Am79C978A controller is not functioning in a Link Pass state with full-duplex operation being enabled, a value of 0 is passed to the LEDOUT signal.			passed to the LEDOUT bit in this register when there is transmit activity on the network.
		This bit is always read/write accessible. FDLSE is cleared by H_RESET and is not affected by S_RESET or setting the STOP bit.	3	POWER	Power. When this bit is set to 1, the device is operating in HIGH power mode.
7	PSE	Pulse Stretcher Enable. When this bit is set, the LED illumination time is extended for each new occurrence of the enabled function for this LED output. A value of 0 disables the pulse stretcher.	2	RCVE	Receive Status Enable. When this bit is set, a value of 1 is passed to the LEDOUT bit in this register when there is receive activity on the network.
		This bit is always read/write accessible. PSE is set to 1 by H_RESET and is not affected by S_RESET or setting the STOP bit.	1	SPEED	Speed. When this bit is set to 1, the device is operating in HIGH speed mode.
6	LNKSE	Link Status Enable. When this bit is set, a value of 1 will be passed to the LEDOUT bit in this register in Link Pass state.	0	COLE	Collision Status Enable. When this bit is set, a value of 1 is passed to the LEDOUT bit in this register when there is collision activity on the network.
		This bit is always read/write accessible. LNKSE is cleared by H_RESET and is not affected by S_RESET or setting the STOP bit.			This bit is always read/write accessible. COLE is cleared by H_RESET and is not affected by S_RESET or setting the STOP bit.
5	RCVME	Receive Match Status Enable. When this bit is set, a value of 1 is passed to the LEDOUT bit in this register when there is receive activity on the network that has passed the address match function for this node. All address matching modes are included: physical, logical filtering, broadcast, and promiscuous.			
		This bit is always read/write accessible. RCVME is cleared by H_RESET and is not affected by S_RESET or setting the STOP bit.			
4	XMTE	Transmit Status Enable. When this bit is set, a value of 1 is			

BCR49: PHY Select

This register defines which PHY will be able to send and receive data over the MII interface. Bits 15:8 are updated whenever the EEPROM is read, and bits 6:0 are updated *only* if bit 7 is cleared. The bits are defined as follows:

Bit	Name	Description
15	PC_NET	PCnet mode. This bit must always be set.
14-10	RES	Reserved locations. These bits must be written as zeros.

9-8 PHY_SEL_DEFAULT
PHY Select Default. These bits store the desired default PHY. These bits have no effect on the operation of the device and are provided only as a storage location.

7 PHY_SEL_LOOK
PHY Select Lock. Setting this bit prevents the PHY_SEL bits from being overwritten by subsequent soft resets. The user may write this bit at any time. It is cleared during Power-On Reset.

6-2 RES Reserved. Must be written as zero.

1-0 PHY_SEL PHY Select. These bits define the active PHY as follows:

00	10BASE-T PHY
01	HomePNA PHY
10	External PHY
11	Reserved/Undefined

BCR50-BCR55: Reserved Locations

These registers must be 00h.

10BASE-T PHY Management Registers (TBRs)

The Am79C978A home networking device supports the MII basic register set and extended register set. Both sets of registers are accessible through the PHY Management Interface. As specified in the IEEE standard, the basic register set consists of the Control Register (Register 0) and the Status Register (Register 1). The extended register set consists of Registers 2 to 31 (decimal).

Table 47 lists all the 10BASE-T registers implemented in the device. All the reserved registers should not be written to, and reading them will return a zero value.

Table 47. Am79C978A 10BASE-T PHY Management Register Set

Register Address (in Decimal)	Register Name	Basic/Extended
0	PHY Control	B
1	PHY Status	B
2-3	PHY Identifier	E
4	Auto-Negotiation Advertisement	E
5	Auto-Negotiation Link Partner Ability	E
6	Auto-Negotiation Expansion	E
7	Auto-Negotiation Next Page	E
8-15	Reserved	E
16	Interrupt Enable and Status	E
17	PHY Control/Status	E
18	Reserved	E
19	PHY Management Extension	E
20-23	Reserved	E
24	Summary Status	E
25-31	Reserved	E

TBR0: 10BASE-T PHY Control Register (Register 0)
Table 48. TBR0: 10BASE-T PHY Control Register (Register 0)

Reg	Bits	Name	Description	Read/Write (Note 1)	Default Value	Soft Reset
0	15	Soft Reset (Note 2)	When write: 1 = PHY software reset, 0 = normal operation. When read: 1 = reset in process, 0 = reset done.	R/W, SC	0	0
0	14	Loopback	1 = asserts the external LPBCK 0 = deasserts the external LPBCK	R/W	0	0
0	13	Speed Selection (Note 3)	1 = 100 Mbps 0 = 10 Mbps	R/W	1	1
0	12	Auto-Negotiation Enable	1 = enable Auto-Negotiation 0 = disable Auto-Negotiation	R/W	1	1
0	11	Power Down	1 = power down 0 = normal operation	R/W	0	0
0	10	Isolate (Note 4)	1 = electrically isolate PHY 0 = normal operation	R/W	1	1
0	9	Restart Auto-Negotiation	1 = restart Auto-Negotiation 0 = normal operation	R/W, SC	0	0
0	8	Duplex Mode (Note 3)	1 = Full-Duplex 0 = Half-Duplex	R/W	1	Retains previous value
0	7	Collision Test	1 = enable COL signal test 0 = disable COL signal test	R/W	0	0
0	6-0	Reserved	Write as 0, ignore on read	RO	0	0

Notes:

1. R/W = Read/Write, SC = Self Clearing, RO = Read only.
2. Soft Reset does not reset the PDX block. Refer to the Soft Reset Section for details.
3. Bits 8 and 13 have no effect if Auto-Negotiation is enabled (Bit 12 = 1).
4. If the ISOL pin of the chip and the Isolate bit in Register 0 is 1, this bit will be set.

TBR1: 10BASE-T Status Register (Register 1)

The Status Register identifies the physical and Auto-negotiation capabilities of the local PHY. This register is read only; a write will have no effect.

Table 49. TBR1: 10BASE-T PHY Status Register (Register 1)

Reg	Bits	Name	Description	Read/Write (Note 1)	Default Value
1	15	100BASE-T4	1 = 100BASE-T4 able 0 = not 100BASE-T4 able	RO	0
1	14	100BASE-X Full-Duplex	1 = 100BASE-X full-duplex able 0 = not 100BASE-X full-duplex able	RO	0
1	13	100BASE-X Half-Duplex	1 = 100BASE-X half-duplex able 0 = not 100BASE-X half-duplex able	RO	0
1	12	10 Mbps Full-Duplex	1 = 10 Mbps full-duplex able 0 = not 10 Mbps full-duplex able	RO	1
1	11	10 Mbps Half-Duplex	1 = 10 Mbps half-duplex able 0 = not 10 Mbps half-duplex able	RO	1
1	10-7	Reserved	Ignore when read	RO	0
1	6	MF Preamble Suppression	1 = PHY can accept management (mgmt) frames with or without preamble 0 = PHY can only accept mgmt frames with preamble	RO	1
1	5	Auto-Negotiation Complete	1 = Auto-Negotiation completed 0 = Auto-Negotiation not completed	RO	0
1 (Note 1)	4	Remote Fault	1 = remote fault detected 0 = no remote fault detected	RO, LH	0
1	3	Auto-Negotiation Ability	1 = PHY able to auto-negotiate 0 = PHY not able to auto-negotiate	RO	1
1 (Note 1)	2	Link Status	1 = link is up 0 = link is down	RO, LL	0
1	1	Jabber Detect	1 = jabber condition detected 0 = no jabber condition detected	RO	0
1	0	Extended Capability	1 = extended register capabilities 0 = basic register set capabilities only	RO	1

Note:

1. LH = Latching High, LL = Latching Low.

TBR2 and TBR3: 10BASE-T PHY Identifier (Registers 2 and 3)

Registers 2 and 3 contain a unique PHY identifier, consisting of 22 bits of the organizationally unique IEEE Identifier, a 6-bit manufacturer’s model number, and a 4-bit manufacturer’s revision number. The most significant bit of the PHY identifier is bit 15 of Register 2; the least significant bit of the PHY identifier is bit 0 of

Register 3. Register 2, bit 15 corresponds to bit 3 of the IEEE Identifier and register 2, bit 0 corresponds to bit 18 of the IEEE Identifier. Register 3, bit 15 corresponds to bit 19 of the IEEE Identifier and register 3, bit 10 corresponds to bit 24 of the IEEE Identifier. Register 3, bits 9-4 contain the manufacturer’s model number and bits 3-0 contain the manufacturer’s revision number. These registers are shown in Table 50 and Table 51.

Table 50. TBR2: 10BASE-T PHY Identifier (Register 2)

Reg	Bits	Name	Description	Read/Write	Default Value	Soft Reset
2	15-0	PHY_ID[31-16]	IEEE Address (bits 3-18); Register 2, bit 15 is MS bit of PHY Identifier	RO	0000000000000000 (0000 Hex)	Retains original Value

Table 51. TBR3: 10BASE-T PHY Identifier (Register 3)

Reg	Bits	Name	Description	Read/Write	Default Value	Soft Reset
3	15-10	PHY_ID[15-10]	IEEE Address (bits 19-24)	RO	011010 (1A Hex)	Retains original value
3	9-4	PHY_ID[9-4]	Manufacturer's Model Number (bits 5-0)	RO	110111 (BA Hex)	Retains original value
3	3-0	PHY_ID[3-0]	Revision Number (bits 3-0); Register 3, bit 0 is LS bit of PHY Identifier	RO	0000	Retains original value

TBR4: 10BASE-T Auto-Negotiation Advertisement Register (Register 4)

This register contains the advertised ability of the Am79C978A home networking device. The purpose of

this register is to advertise the technology ability to the link partner device. See Table 52.

When this register is modified, Restart Auto-Negotiation (Register 0, bit 9) must be enabled to guarantee the change is implemented.

Table 52. TBR4: 10BASE-T Auto-Negotiation Advertisement Register (Register 4)

Bit(s)	Name	Description	Read/Write	H/W or Soft Reset
15	Next Page	When set, the device wishes to engage in next page exchange. If clear, the device does not wish to engage in next page exchange.	R/W	0
14	Reserved		RO	0
13	Remote Fault	When set, a remote fault bit is inserted into the base link code word during the Auto Negotiation process. When cleared, the base link code work will have the bit position for remote fault as cleared.	R/W	0
12:11	Reserved		RO	0
10	PAUSE	This bit should be set if the PAUSE capability is to be advertised.	R/W	0
9	Reserved		RO	0
8	Full-Duplex – 100BASE-TX	This bit advertises Full-Duplex capability. When set, Full-Duplex capability is advertised. When cleared, Full-Duplex capability is not advertised.	R/W	0
7	Half-Duplex – 100BASE-TX	This bit advertises Half-Duplex capability for the Auto-negotiation process. Setting this bit advertises half-duplex capability. Clearing this bit does not advertise half-duplex capability.	R/W	0
6	Full-Duplex – 10BASE-T	This bit advertises Full-Duplex capability. When set, Full-Duplex capability is advertised. When cleared, Full-Duplex capability is not advertised.	R/W	1
5	Half-Duplex – 10BASE-T	This bit advertises Half-Duplex capability for the Auto-negotiation process. Setting this bit advertises Half-Duplex capability. Clearing this bit does not advertise Half-Duplex capability.	R/W	1
4:0	Selector Field	The Am79C978A home networking device is an 802.3 compliant device	RO	0x01

TBR5: 10BASE-T Auto-Negotiation Link Partner Ability Register (Register 5)

The Auto-Negotiation Link Partner Ability Register is Read Only. The register contains the advertised ability of

the link partner. The bit definitions represent the received link code word. This register contains either the base page or the link partner's next pages. See Table 53 and Table 54.

Table 53. TBR5: 10BASE-T Auto-Negotiation Link Partner Ability Register (Register 5) - Base Page Format

Bit(s)	Name	Description	Read/Write	H/W or Soft Reset
15	Next Page	Link partner next page request	RO	0
14	Acknowledge	Link partner acknowledgment	RO	0
13	Remote Fault	Link partner remote fault request	RO	0
12:5	Technology Ability	Link partner technology ability field	RO	0
4:0	Selector Field	Link partner selector field	RO	0

Table 54. TBR5: 10BASE-T Auto-Negotiation Link Partner Ability Register (Register 5) - Next Page Format

Bit(s)	Name	Description	Read/Write	H/W or Soft Reset
15	Next Page	Link partner next page request	RO	0
14	Acknowledge	Link partner acknowledgment	RO	0
13	Message Page	Link partner message page request	RO	0
12	Acknowledge 2	1 = Link partner can comply with the request 0 = Link partner cannot comply with the request	RO	0
11	Toggle	Link partner toggle bit	RO	0
10:0	Message Field	Link partner's message code	RO	0

TBR6: 10BASE-T Auto-Negotiation Expansion Register (Register 6)

process. The Auto-Negotiation Expansion Register bits are Read Only. See Table 55.

The Auto-Negotiation Expansion Register provides additional information which aids the Auto-Negotiation

Table 55. TBR6: 10BASE-T Auto-Negotiation Expansion Register (Register 6)

Bit(s)	Name	Description	Read/Write	H/W or Soft Reset
15:5	Reserved		RO	0
4	Parallel Detection Fault	1 = Parallel detection fault 0 = No parallel detection fault	RO, LH	0
3	Link Partner Next Page Able	1 = Link partner is next page able 0 = Link partner is not next page able	RO	0
2	Next Page Able	1 = Am79C978A home networking device channel is next page able 0 = Am79C978A home networking device channel is not next page able	RO	1
1	Page Received	1 = A new page has been received 0 = A new page has not been received	RO, LH	0
0	Link Partner ANEG Able	1 = Link partner is Auto-Negotiation able 0 = Link partner is not Auto-Negotiation able	RO	0

TBR7: 10BASE-T Auto-Negotiation Next Page Register (Register 7)

the default value of 2001h represents a message page with the message code set to null. See Table 56.

The Auto-Negotiation Next Page Register contains the next page link code word to be transmitted. On power-up

Table 56. TBR7: 10BASE-T Auto-Negotiation Next Page Register (Register 7)

Bit(s)	Name	Description	Read/Write	H/W or Soft Reset
15	Next Page	Am79C978A home networking device channel next page request	R/W	0
14	Reserved		RO	0
13	Message Page	Am79C978A home networking device channel message page request	R/W	1
12	Acknowledge 2	1 = Am79C978A home networking device channel can comply with the request 0 = Am79C978A home networking device channel cannot comply with the request	R/W	0
11	Toggle	Am79C978A home networking device channel toggle bit	RO	0
10:0	Message Field	Message code field	R/W	0x001

Reserved Registers (Registers 8-15, 18, 20-23, and 25-31)

reserved registers at addresses 8-15, 18, 20-23, and 25-31. These registers should be ignored when read and should not be written at any time.

The Am79C978A home networking device contains

TBR16: 10BASE-T INTERRUPT Status and Enable Register (Register 16)

The Interrupt bits indicate when there is a change in the Link Status, Duplex Mode, Auto-Negotiation status, or Speed status. Register 16 contains the interrupt status

and interrupt enable bits. The status is always updated whether or not the interrupt enable bits are set. When an interrupt occurs, the system will need to read the interrupt register to clear the status bits and determine the course of action needed. See Table 57.

Table 57. TBR16: 10BASE-T INTERRUPT Status and Enable Register (Register 16)

Bit(s)	Name	Description	Read/Write	H/W or Soft Reset
15:14	Reserved		RO	0
13	Interrupt Test Enable (Note 1)	1 = When this bit is set, setting bits 12:9 of this register will cause a condition that will set bits 4:1 accordingly. The effect is to test the register bits with a forced interrupt condition. 0 = Bits 4:1 are only set if the interrupt condition (if any bits in 12:9 are set) occurs.	R/W	0
12	Link Status Change Enable	1 = Link Status Change enable 0 = This interrupt is masked	R/W	0
11	Duplex Mode Change Enable	1 = Duplex Mode Change enable 0 = This interrupt is masked	R/W	0
10	Auto-Neg Change Enable	1 = Auto-Negotiation Change enable 0 = This interrupt is masked	R/W	0
9	Speed Change Enable	1 = Speed Change enable 0 = This interrupt is masked	R/W	0
8	Global Enable	1 = Global Interrupt enable 0 = This interrupt is masked	R/W	0
7:5	Reserved		RO	0
4	Link Status Change	1 = Link Status has changed on a port 0 = No change in Link Status	RO, LH	0
3	Duplex Mode Change	1 = Duplex Mode has changed on a port 0 = No change in Duplex mode	RO, LH	0
2	Auto-Negotiation Change	1 = Auto-Neg status has changed on a port 0 = No change in Auto-Neg status	RO, LH	0
1	Speed Change	1 = Speed status has changed on a port 0 = No change	RO, LH	0
0	Global	1 = Indicates a change in status of any of the above interrupts 0 = Indicates no change in Interrupt Status	RO, LH	0

Note:

1. All bits, except bit 13, are cleared on read (COR). The register must be read twice to see if it has been cleared.

TBR17: 10BASE-T PHY Control/Status Register (Register 17)

This register is used to control the configuration of the 10 Mbps PHY unit of the Am79C978A home networking device. See Table 58.

Table 58. TBR17: 10BASE-T PHY Control/Status Register (Register 17)

Reg	Bits	Name	Description	Read/Write	H/W Reset	Soft Reset
17	15	Reserved		R/W	0	Retains Previous Value
17	14	Reserved		R/W	0	Retains Previous Value
17	13	Force Link Good Enable	1 = Link status forced to link up state 0 = Link status is determined by the device	R/W	0	0
17	12	Disable Link Pulse	1 = Link pulses sent from the 10BASE-T transmitter are suppressed	R/W	0	0
17	11	SQE_TEST Disable	1 = Disables the SQE heartbeat which occurs after each 10BASE-T transmission 0 = The heart beat assertion occurs on the COL pin approximately 1 μ s after transmission and for a duration of 1 μ s.	R/W	0	0
17	10	Reserved		R/W	0	0
17	9	Jabber Detect Disable	1 = Disable jabber detect 0 = Enable jabber detect	R/W	0	0
17	8:7	Reserved		R/W	00	00
17	6	Receive Polarity Reversed	1 = Receive polarity of the 10BASE-T receiver is reversed 0 = Receive polarity is correct	RO	0	0
17	5	Auto Receive Polarity Correction Disable	1 = Polarity correction circuit is disabled for 10BASE-T 0 = Self correcting polarity circuit is enabled	R/W	0	0
17	4	Extended Distance Enable	1 = 10BASE-T receive squelch thresholds are reduced to allow reception of frames which are greater than 100 meters 0 = Squelch thresholds are set for standard distance of 100 meters	R/W	0	0
17	3	TX_DISABLE	1 = TX \pm outputs not active for 10BASE-T. TX \pm outputs to logical "0" for PECL. 0 = Transmit valid data	R/W	0	0
17	2	TX_CRIS_EN	1 = CRS is asserted when transmit or receive medium is active 0 = CRS is asserted when receive medium is active	RO	0	0
17	1	Reserved		RO	0	0
17	0	PHY Isolated	1 = Internal PHY is isolated 0 = Internal PHY is enabled	RO	0/1	0/1

Note:

1. For these loopback paths, the data is also transmitted out of the MDI pins (TX \pm).

TBR19: 10BASE-T PHY Management Extension Register (Register 19)

Table 59 contains the PHY Management Extension Register (Register 19) bits.

Table 59. TBR19: 10BASE-T PHY Management Extension Register (Register 19)

Reg	Bits	Name	Description	Read/Write	Default Value	Soft Reset
19	15:6	Reserved	Write as 0; ignore on read	RO	0	0
19	5	Mgmt Frame Format	1 = Last management frame was invalid (opcode error, etc.) 0 = Last management frame was valid	RO	0	0
19	4-0	PHY Address	PHY Address defaults to 11110	RO	11110	Retains Previous Value

Reserved Register: 10BASE-T Configuration Register (Register 22)

This register is reserved.

Reserved Register: 10BASE-T Carrier Status Register (Register 23)

This register is reserved.

TBR24: 10BASE-T Summary Status Register (Register 24)

The Summary Status register is a global register containing status information. This register is Read/Only and represents the most important data which a single register access can convey. The Summary Status register indicates the following: Link Status, Full-Duplex Status, Auto-Negotiation Alert, and Speed. See Table 60.

Table 60. TBR24: 10BASE-T Summary Status Register (Register 24)

Bit(s)	Name	Description	Read/Write	H/W or Soft Reset
15-4	Reserved	Write as 0; Ignore on Read	0	0
3	Link Status	1 = Link Status is up 0 = Link Status is down	R/O	0
2	Full-Duplex	Operating in Full-Duplex mode Operating in Half-Duplex mode	R/O	0
1	AutoNEG Alert	1 = AutoNEG status has changed 0 = AutoNEG status unchanged	R/O	0
0	Speed	1 = Operating at 100 Mbps 0 = Operating at 10 Mbps	R/O	0

1 Mbps HomePNA PHY Internal Registers

The registers of the HomePNA PHY are accessible via the internal MII interface. This interface uses the MII Control, Address, and Data Registers (BCR32,

BCR33, and BCR34) in the integrated PCnet controller to control and communicate to the HomePNA PHY via the MDC and MDIO signals.

See Table 61 through Table 75.

HPR0: HomePNA PHY MII Control (Register 0)

Table 61. HPR0: HomePNA PHY MII Control (Register 0)

Address		Mnemonic	Description	Read/ Write	Default Hex	Soft Reset
Hex	Bits					
00		MII_CONTROL				
	15	RESET	1 = RESET 0 = Normal operation ** Self Clearing	R/W	0	0
	14	Loopback	1 = MII Loopback enabled 0 = MII Loopback disabled	R/W	0	0
	13	Speed Selection	0 = 10 Mbps	R	0	0
	12	Auto-Negotiation Enabled	1 = Enabled 0 = Disabled	R/W	0	0
	11	Power Down	1 = Power down 0 = Normal operation (This bit is mirrored in PHY Control bit 4)	R/W	0	0
	10	Isolate	1 = Electrically isolate PHY from MII 0 = Normal operation	R/W	1	1
	9	Restart Auto-Negotiation	1 = Restart Auto-Negotiation 0 = Normal operation ** Self Clearing	R/W	0	0
	8	Duplex Mode	1 = Full-Duplex 0 = Half-Duplex	R	0	0
	7	Collision Test	1 = Enable COL test signal 0 = Disable COL test signal	R/W	0	0
	6:0	Reserved	Write as 0, Ignore Read	R/W	0	0

HPR1: HomePNA PHY MII Status (Register 1)
Table 62. HPR1: HomePNA PHY MII Status (Register 1)

Address		Mnemonic	Description	Read/ Write	Default Hex	Soft Reset
Hex	Bits					
01		MII_Status				
	15	100BASE-T4	0 = PHY not able to perform 100BASE-T4	R	0	0
	14	100BASE-X Full-Duplex	0 = PHY not able to perform Full-Duplex 100BASE-X	R	0	0
	13	100BASE-X Half-Duplex	0 = PHY not able to perform Half-Duplex 100BASE-X	R	0	0
	12	10 Mbps Full-Duplex	0 = PHY not able to perform 10 Mbps in Full-Duplex	R	0	0
	11	10 Mbps Half-Duplex	1 = PHY able to perform 10 Mbps in Half-Duplex	R	1	1
	10:7	Reserved	Reads will produce undefined results	R		
	6	MF Preamble Suppression	1 = PHY will accept management frames with Preamble suppressed 0 = PHY will not accept management frames with Preamble suppressed	R	1	1
	5	Auto-Negotiation Complete	1 = Auto-Negotiation completed 0 = Auto-Negotiation not completed	R	0	0
	4	Remote Fault	1 = Remote fault detected 0 = Normal operation	R	0	0
	3	Auto-Negotiation Ability	1 = PHY is able to perform Auto-Negotiation 0 = PHY is not able to perform Auto- Negotiation	R	0	0
	2	Link Status	1 = Link is up 0 = Link is down This bit will be RESET (latched low and re- enabled on Read) on the first occurrence of lost link and will be SET after completion of valid LINK process.	R	0	0
	1	Jabber Detect	1 = Jabber condition detected 0 = Normal operation	R	0	0
	0	Extended Capability	1 = Extended Register Capability 0 = Basic Register Set Capability	R	1	1

HPR2 and HPR3: HomePNA PHY MII PHY ID (Registers 2 and 3)

Table 63. HPR2 and HPR3: HomePNA PHY MII ID (Registers 2 and 3)

Address		Mnemonic	Description	Read/ Write	Default Hex	Soft Reset
Hex	Bits					
02		MII_PHY_ID				
	15:0	PHY_ID MSB (31-16)	Most significant bytes of the PHY_ID (Bits 3-18)	R	0000	0000
03		MII_PHY_ID				
	15:10	PHY_ID LSB (15-10)	IEEE Address (Bits 19-24)	R	1A	1A
	9:4	PHY_ID LSB (9-4)	Manufacturer Model Number	R	39	39
	3:0	PHY_ID LSB (3-0)	Revision Number	R	0	0

HPR4-HPR7: HomePNA PHY Auto-Negotiation (Registers 4 - 7)

Table 64. HPR4-HPR7: HomePNA PHY Auto-Negotiation (Registers 4 - 7)

Address		Mnemonic	Description	Read/ Write	Default Hex	Soft Reset
Hex	Bits					
04		Auto-Negotiation Register 4	Advertisement	R	0021	0021
05		Auto-Negotiation Register 5	Link Partner Ability	R	0000	0000
06		Auto-Negotiation Register 6	Expansion	R	0000	0000
07		Auto-Negotiation Register 7	Next Page	R	0000	0000

Reserved Registers: HPR8 - HPR15, HPR17

These registers should be ignored when read and should not be written to at any time.

HPR16: HomePNA PHY Control (Register 16)
Table 65. HPR16: HomePNA PHY Control (Register 16)

Address		Mnemonic	Description	Read/ Write	Default Hex	Soft Reset
Hex	Bits					
10		PHY_Control				
	15	Remote Command	1 = Ignore Remote Commands 0 = Normal operation	R/W	0	0
	14:12	Reserved	Reads will produce undefined results	R/W		
	11	Command Low Power	1 = Command low power 0 = Normal operation	R/W	0	0
	10	Command High Power	1 = Command high power 0 = Normal operation	R/W	0	0
	9	Command Low Speed	1 = Command low speed 0 = Normal operation	R/W	0	0
	8	Command High Speed	1 = Command high speed 0 = Normal operation	R/W	0	0
	7	Disable AID Negotiation	1 = Disable AID negotiation 0 = Normal operation	R/W	0	0
	6	Clear PHY-Event Counter	1 = Clear PHY event counter 0 = Normal operation	R/W	0	0
	5	Disable Squelch adaptation	1 = Disable Squelch adaptation 0 = Normal operation	R/W	0	0
	4	Power Down	1 = Power down 0 = Normal operation (This bit is controlled by the MII_Control bit 11)	R	0	0
	3	Reserved	Reads will produce undefined results	R		
	2	High Speed	1 = High speed 0 = Low speed	R/W	1	1
	1	High Power	1 = High power 0 = Low power	R/W	0	0

HPR18 and HPR19: HomePNA PHY TxCOMM (Registers 18 and 19)

Table 66. HPR18 and HPR19: HomePNA PHY TxCOMM (Registers 18 and 19)

Address		Mnemonic	Description	Read/ Write	Default Hex	Soft Reset
Hex	Bits					
12-13		PHY_TX_COMM (4)	The 32-bit preamble transmitted on the HomePNA PHY. Register 12 contains the high word and Register 13 the low word.	R/W	All 0s	All 0s

The 32-bit transmitted data field is to be used for out-of-band communication between PHY management entities. No protocol for out-of-band management has been defined. Accessing the low word causes the PHY to send all-0 PCOMs until the high word has been accessed. Once accessed, the next transmitted packet will cause this register's contents to be shifted out in

the PCOM field of the transmitted packet. Upon transmission, this register will read back as all 0s. A non-null transmitted PCOM will set the TxPCOM Ready bit in the Event Status Register (Register 1A). An access to any of the two TxPCOM words will clear the TxPCOM Ready bit in the ISTAT register.

HPR20 and HPR21: HomePNA PHY RxCOMM (Registers 20 and 21)

Table 67. HPR20 and HPR21: HomePNA PHY RxCOMM (Registers 20 and 21)

Address		Mnemonic	Description	Read/ Write	Default Hex	Soft Reset
Hex	Bits					
14-15		PHY_RX_COMM (4)	The 32-bit preamble received on the HomePNA PHY. Register 14 contains the high word and Register 15 the low word.	R	All 0s	All 0s

The 32-bit received data field to be used for out-of-band communication between PHY management entities. No protocol for out-of-band management has been defined. Accessing the low word of the register is sufficient to ensure that subsequently received packets

will not over-write the register contents. A non-null received PCOM will set the RxPCOM Valid bit of the Event Status Register (Register 1A). Accessing the high word of the register clears this bit and allows over-writing of the register by subsequent received packets.

HPR22: HomePNA PHY AID (Register 22)
Table 68. HPR22: HomePNA PHY AID (Register 22)

Address		Mnemonic	Description	Read/Write	Default Hex	Soft Reset
Hex	Bits					
16		PHY_AID				
	15:8	PHY_AID	The Address ID of this PHY If PHY_Control Disable AID Negotiation is not set then writes to this bit will have no effect.	R/W	00	00
	7:0	Noise Events	An 8-bit counter that records the number of noise events detected. Overflows are held as FFh. Can be cleared by setting bit 6 of the control register.	R/W	00	00

The PHY's AID address is used for collision detection. Unless bit 7 of the CONTROL register is set, the PHY is assured to select a unique AID address. Addresses

above EFh are reserved. Address FFh is defined to indicate a remote command.

HPR23: HomePNA PHY Noise Control (Register 23)
Table 69. HPR23: HomePNA PHY Noise Control (Register 23)

Address		Mnemonic	Description	Read/Write	Default Hex	Soft Reset
Hex	Bits					
17		PHY_NOISE_CTRL1				
	15:8	Noise Floor	The minimum value of the NOISE measurement.	R/W	03	03
	7:0	Noise Ceiling	The maximum value if the NOISE measurement. If it is exceeded, NOISE is reset to the FLOOR.	R/W	FF	FF

HPR24: HomePNA PHY Noise Control 2 (Register 24)
Table 70. HPR24: HomePNA PHY Noise Control 2 (Register 24)

Address		Mnemonic	Description	Read/Write	Default Hex	Soft Reset
Hex	Bits					
18		PHY_NOISE_CTRL2				
	15:8	Noise Attack	Sets the attack characteristics of the NOISE algorithm. High nibble sets number of noise events needed to raise the NOISE level immediately, while the low nibble is the number of noise events needed to raise the level at the end of an 870 ms period.	R/W	F4	F4
	7:0	Reserved	Reads will produce undefined results	R/W		

HPR25: HomePNA PHY Noise Statistics (Register 25)

Table 71. HPR25: HomePNA PHY Noise Statistics (Register 25)

Address		Mnemonic	Description	Read/ Write	Default Hex	Soft Reset
Hex	Bits					
19		PHY_NOISE_STAT				
	15:8	Noise Level	This is the digital value of the SLICE_LVL_NOISE output. It is effectively a measure of the noise level on the wire and tracks noise by counting the number of false triggers of the NOISE comparator in an 800 ms window. When auto-adaptation is enabled (bit 5 of the PHY_Control Register is false), this register is updated with the current NOISE count every 50 ns. When adaptation is disabled, this register may be written to and is used to generate both the SLICE_LVL_NOISE and SLICE_LVL_DATA signals.	R/W	03	03
	7:0	Peak Level	This is a measurement of the peak level of the last valid (non-collision) AID received.	R/W	D0	S0

HPR26: HomePNA PHY Event Status (Register 26)

Table 72. HPR26: HomePNA PHY Event Status (Register 26)

Address		Mnemonic	Description	Read/ Write	Default Hex	Soft Reset
Hex	Bits					
1A		PHY_Event Status				
	15:10	Reserved		R	0	0
	9	RxPCOM	Indicates a valid RxPCOM. An access to the RxCOM MSB Register 18 will clear this bit.	R	0	0
	8	TxPCOM	Indicates a valid TxPCOM. Any access to the TxCOM registers (Registers 20 and 21) will clear this bit.	R	0	0
	7:4	Reserved	Reads will produce undefined results.	R		
	3	Packet Received	Status is cleared by writing a 0.	R/W	0	0
	2	Packet Transmitted	Status is cleared by writing a 0.	R/W	0	0
	1	Remote Command Received	A valid remote command was received. Status is cleared by writing a 0.	R/W	0	0
	0	Remote Command Sent	A remote command has been sent. Status is cleared by writing a 0.	R/W	0	0

HPR27: HomePNA PHY Event Status (Register 27)

The Event Status register reports the state of each event source. Any bit may be written and so facilitate software-stimulated event testing.

Table 73. HPR27: HomePNA PHY Event Status (Register 27)

Address		Mnemonic	Description	Read/Write	Default Hex	Soft Reset
Hex	Bits					
1B		AID_CTRL				
	15:8	AID_INTERVAL	This value defines the number of TCLKs (116.6 ns) separating AID symbols.	R/W	14	14
	7:0	AID_ISBI	This value defines the number of TCLKs (116.6 ns) separating AID symbol 0.	R/W	40	40

HPR28: HomePNA PHY ISBI Control (Register 28)

Table 74. HPR28: HomePNA PHY ISBI Control (Register 28)

Address		Mnemonic	Description	Read/Write	Default Hex	Soft Reset
Hex	Bits					
1C		ISBI_CTRL				
	15:8	ISBI_SLOW	This value defines the number of TCLKs (116.6 ns) separating data pulses for Symbol 0 in low speed mode.	R/W	2C	2C
	7:0	ISBI_FAST	This value defines the number of TCLKs (116.6 ns) separating data pulses for Symbol 0 in high speed mode.	R/W	1C	1C

HPR29: HomePNA PHY TX Control (Register 29)

Table 75. HPR29: HomePNA PHY TX Control (Register 29)

Address		Mnemonic	Description	Read/Write	Default Hex	Soft Reset
Hex	Bits					
1D		TX_CTRL				
	15:8	TX_PULSE_WIDTH	This value defines the duration of a transmit pulse in OSC cycles (16.7 ns). This will effectively determine the transmit spectrum of the PHY.	R/W	04	04
	7:4	TX_PULSE_CYCLES_N	This value defines the number of pulses that will be driven onto the HRTXR_N pin.	R/W	4	4
	3:0	TX_PULSE_CYCLES_P	This value defines the number of pulses that will be driven onto the HRTXR_P pin.	R/W	4	4

Initialization Block

Note: When SSIZE32 (BCR20, bit 8) is set to 0, the software structures are defined to be 16 bits wide. The base address of the initialization block must be aligned to a DWord boundary, i.e., CSR1, bit 1 and 0 must be cleared to 0. When SSIZE32 is set to 0, the initialization block looks like Table 76.

Note: The Am79C978A controller performs DWord accesses to read the initialization block. This statement is always true, regardless of the setting of the SSIZE32 bit.

When SSIZE32 (BCR20, bit 8) is set to 1, the software structures are defined to be 32 bits wide. The base address of the initialization block must be aligned to a DWord boundary, i.e., CSR1, bits 1 and 0 must be cleared to 0. When SSIZE32 is set to 1, the initialization block looks like Table 77.

Table 76. Initialization Block (SSIZE32 = 0)

Address	Bits 15-13	Bit 12	Bits 11-8	Bits 7-4	Bits 3-0
IADR+00h			MODE 15-00		
IADR+02h			PADR 15-00		
IADR+04h			PADR 31-16		
IADR+06h			PADR 47-32		
IADR+08h			LADRF 15-00		
IADR+0Ah			LADRF 31-16		
IADR+0Ch			LADRF 47-32		
IADR+0Eh			LADRF 63-48		
IADR+10h			RDRA 15-00		
IADR+12h	RLEN	0	RES		TDRA 23-16
IADR+14h			TDRA 15-00		
IADR+16h	TLEN	0	RES		TDRA 23-16

Table 77. Initialization Block (SSIZE32 = 1)

Address	Bits	Bits	Bits	Bits	Bits	Bits	Bits	Bits
	31-28	27-24	23-20	19-16	15-12	11-8	7-4	3-0
IADR+00h	TLEN	RES	RLEN	RES	MODE			
IADR+04h	PADR 31-00							
IADR+08h	RES				PADR 47-32			
IADR+0Ch	LADRF 31-00							
IADR+10h	LADRF 63-32							
IADR+14h	RDRA 31-00							
IADR+18h	TDRA 31-00							

RLEN and TLEN

When SSIZE32 (BCR20, bit 8) is set to 0, the software structures are defined to be 16 bits wide, and the RLEN and TLEN fields in the initialization block are each three bits wide. The values in these fields determine the number of transmit and receive Descriptor Ring Entries (DRE) which are used in the descriptor rings. Their meaning is shown in Table 78. If a value other than those

listed in Table 79 is desired, CSR76 and CSR78 can be written after initialization is complete.

When SSIZE32 (BCR20, bit 8) is set to 1, the software structures are defined to be 32 bits wide, and the RLEN and TLEN fields in the initialization block are each four bits wide. The values in these fields determine the number of transmit and receive Descriptor Ring Entries (DRE) which are used in the descriptor rings. Their meaning is shown in Table 79.

If a value other than those listed in Table 78 is desired, CSR76 and CSR78 can be written after initialization is complete.

Table 78. R/TLEN Decoding (SSIZE32 = 0)

R/TLEN	Number of DREs
000	1
001	2
010	4
011	8
100	16
101	32
110	64
111	128

RDRA and TDRA

RDRA and TDRA indicate where the transmit and receive descriptor rings begin. Each DRE must be located at a 16-byte address boundary when SSIZE32 is set to 1 (BCR20, bit 8). Each DRE must be located at an 8-byte address boundary when SSIZE32 is set to 0 (BCR20, bit 8).

Table 79. R/TLEN Decoding (SSIZE32 = 1)

R/TLEN	Number of DREs
0000	1
0001	2
0010	4
0011	8
0100	16
0101	32
0110	64
0111	128
1000	256
1001	512
11XX	512
1X1X	512

LADRF

The Logical Address Filter (LADRF) is a 64-bit mask that is used to accept incoming Logical Addresses. If the first bit in the incoming address (as transmitted on the wire) is a 1, it indicates a logical address. If the first bit is a 0, it is a physical address and is compared

against the physical address that was loaded through the initialization block.

A logical address is passed through the CRC generator, producing a 32-bit result. The high order 6 bits of the CRC is used to select one of the 64 bit positions in the Logical Address Filter. If the selected filter bit is set, the address is accepted and the frame is placed into memory.

The Logical Address Filter is used in multicast addressing schemes. The acceptance of the incoming frame based on the filter value indicates that the message may be intended for the node. It is the node's responsibility to determine if the message is actually intended for the node by comparing the destination address of the stored message with a list of acceptable logical addresses.

If the Logical Address Filter is loaded with all zeros and promiscuous mode is disabled, all incoming logical addresses except broadcast will be rejected. If the DRCVBC bit (CSR15, bit 14) is set as well, the broadcast packets will be rejected. See Figure 51.

PADR

This 48-bit value represents the unique node address assigned by the ISO 8802-3 (IEEE/ANSI 802.3) and used for internal address comparison. PADR[0] is compared with the first bit in the destination address of the incoming frame. It must be 0 since only the destination address of a unicast frames is compared to PADR. The six hex-digit nomenclature used by the ISO 8802-3 (IEEE/ANSI 802.3) maps to the Am79C978A home networking PADR register as follows: the first byte is compared with PADR[7:0] with PADR[0] being the least significant bit of the byte. The second ISO 8802-3 (IEEE/ANSI 802.3) byte is compared with PADR[15:8], again from the least significant bit to the most significant bit, and so on. The sixth byte is compared with PADR[47:40], the least significant bit being PADR[40].

Mode

The mode register field of the initialization block is copied into CSR15 and interpreted according to the description of CSR15.

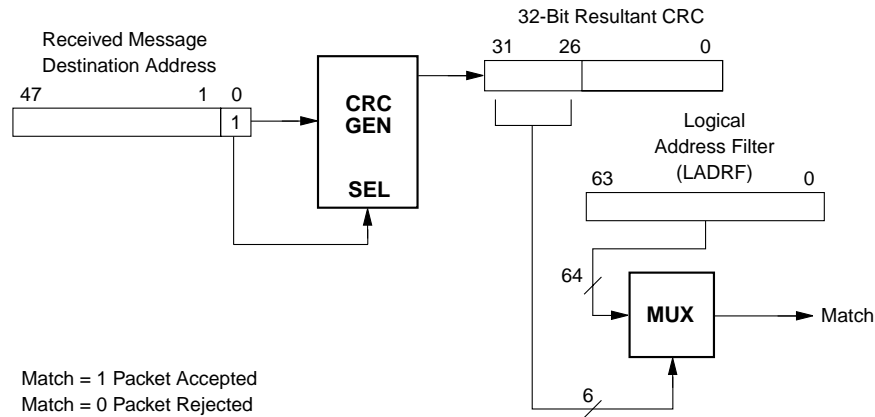

22399A-54

Figure 51. Address Match Logic

Receive Descriptors

When SWSTYLE (BCR20, bits 7-0) is set to 0, then the software structures are defined to be 16 bits wide, and receive descriptors look like Table 80 (CRDA = Current Receive Descriptor Address).

When SWSTYLE (BCR 20, bits 7-0) is set to 2, then the software structures are defined to be 32 bits wide, and

receive descriptors look like Table 81 (CRDA = Current Receive Descriptor Address).

When SWSTYLE (BCR 20, bits 7-0) is set to 3, then the software structures are defined to be 32 bits wide, and receive descriptors look like Table 82 (CRDA = Current Receive Descriptor Address).

Table 80. Receive Descriptor (SWSTYLE = 0)

Address	15	14	13	12	11	10	9	8	7-0
CRDA+00h	RBADR[15:0]								
CRDA+02h	OWN	ERR	FRAM	OFLO	CRC	BUFF	STP	ENP	RBADR[23:16]
CRDA+04h	1	1	1	1	BCNT				
CRDA+06h	0	0	0	0	MCNT				

Table 81. Receive Descriptor (SWSTYLE = 2)

Address	31	30	29	28	27	26	25	24	23	22	21	20	19-16	15-12	11-0
CRDA+00h	RBADR[31:0]														
CRDA+04h	OWN	ERR	FRM	OFL O	CRC	BUF F	STP	ENP	BPE	PAM	LAFM	BAM	RES	1111	BCNT
CRDA+08h	RES	RFRTAG[14:0]												0000	MCNT
CRDA+0Ch	USER SPACE														

Table 82. Receive Descriptor (SWSTYLE = 3)

Address	31	30	29	28	27	26	25	24	23	22-16	15-12	11-0	
CRDA+00h	RES									RES	RES	0000	MCNT
CRDA+04h	OWN	ERR	FRAM	OFLO	CRC	BUFF	STP	ENP	BPE	RES	1111	BCNT	
CRDA+08h	RBADR[31:0]												
CRDA+0Ch	USER SPACE												

RMD0

Bit	Name	Description
31-0	RBADR	Receive Buffer address. This field contains the address of the receive buffer that is associated with this descriptor.

RMD1

Bit	Name	Description
31	OWN	This bit indicates whether the descriptor entry is owned by the host (OWN = 0) or by the Am79C978A controller (OWN = 1). The Am79C978A controller clears the OWN bit after filling the buffer that the descriptor points to. The host sets the OWN bit after emptying the buffer. Once the Am79C978A controller or host has relinquished ownership of a buffer, it must not change any field in the descriptor entry.
30	ERR	ERR is the OR of FRAM, OFLO, CRC, BUFF, or BPE. ERR is set by the Am79C978A controller and cleared by the host.
29	FRAM	Framing error indicates that the incoming frame contains a non-integer multiple of eight bits and there was an FCS error. If there was no FCS error on the incoming frame, then FRAM will not be set even if there was a non-integer multiple of eight bits in the frame. FRAM is not valid in internal loopback mode. FRAM is valid only when ENP is set and OFLO is not. FRAM is set by the Am79C978A controller and cleared by the host.
28	OFLO	Overflow error indicates that the receiver has lost all or part of the incoming frame, due to an inability to move data from the receive FIFO into a memory buffer before the internal FIFO overflowed. OFLO is set by the Am79C978A controller and cleared by the host.

27 CRC
CRC indicates that the receiver has detected a CRC (FCS) error on the incoming frame. CRC is valid only when ENP is set and OFLO is not. CRC is set by the Am79C978A controller and cleared by the host. CRC will also be set when Am79C978A home networking receives an RX_ER indication from the external PHY through the MII.

26 BUFF
Buffer error is set any time the Am79C978A controller does not own the next buffer while data chaining a received frame. This can occur in either of two ways:

1. The OWN bit of the next buffer is 0.

2. FIFO overflow occurred before the Am79C978A controller was able to read the OWN bit of the next descriptor.

If a Buffer Error occurs, an Overflow Error may also occur internally in the FIFO, but will not be reported in the descriptor status entry unless both BUFF and OFLO errors occur at the same time. BUFF is set by the Am79C978A controller and cleared by the host.

25 STP
Start of Packet indicates that this is the first buffer used by the Am79C978A controller for this frame. If STP and ENP are both set to 1, the frame fits into a single buffer. Otherwise, the frame is spread over more than one buffer. When LAPPEN (CSR3, bit 5) is cleared to 0, STP is set by the Am79C978A controller and cleared by the host. When LAPPEN is set to 1, STP must be set by the host.

24 ENP
End of Packet indicates that this is the last buffer used by the Am79C978A controller for this frame. It is used for data chaining buffers. If both STP and ENP are set, the frame fits into one buffer and there is no data chaining. ENP is set by the Am79C978A controller and cleared by the host.

23	BPE	<p>Bus Parity Error is set by the Am79C978A controller when a parity error occurred on the bus interface during data transfers to a receive buffer. BPE is valid only when ENP, OFLO, or BUFF are set. The Am79C978A controller will only set BPE when the advanced parity error handling is enabled by setting APERREN (BCR20, bit 10) to 1. BPE is set by the Am79C978A controller and cleared by the host.</p> <p>This bit does not exist when the Am79C978A controller is programmed to use 16-bit software structures for the descriptor ring entries (BCR20, bits 7-0, SWSTYLE is cleared to 0).</p>		<p>that a Broadcast frame would pass the hash filter, LAFM will be set on the reception of a Broadcast frame.</p> <p>This bit does not exist when the Am79C978A controller is programmed to use 16-bit software structures for the descriptor ring entries (BCR20, bits 7-0, SWSTYLE is cleared to 0).</p>	
22	PAM	<p>Physical Address Match is set by the Am79C978A controller when it accepts the received frame due to a match of the frame's destination address with the content of the physical address register. PAM is valid only when ENP is set. PAM is set by the Am79C978A controller and cleared by the host.</p> <p>This bit does not exist when the Am79C978A controller is programmed to use 16-bit software structures for the descriptor ring entries (BCR20, bits 7-0, SWSTYLE is cleared to 0).</p>	20	<p>BAM</p> <p>Broadcast Address Match is set by the Am79C978A controller when it accepts the received frame, because the frame's destination address is of the type "Broadcast." BAM is valid only when ENP is set. BAM is set by the Am79C978A controller and cleared by the host.</p> <p>This bit does not exist when the Am79C978A controller is programmed to use 16-bit software structures for the descriptor ring entries (BCR20, bits 7-0, SWSTYLE is cleared to 0).</p>	
21	LAFM	<p>Logical Address Filter Match is set by the Am79C978A controller when it accepts the received frame based on the value in the logical address filter register. LAFM is valid only when ENP is set. LAFM is set by the Am79C978A controller and cleared by the host.</p> <p>Note that if DRCVBC (CSR15, bit 14) is cleared to 0, only BAM, but not LAFM will be set when a Broadcast frame is received, even if the Logical Address Filter is programmed in such a way that a Broadcast frame would pass the hash filter. If DRCVBC is set to 1 and the Logical Address Filter is programmed in such a way</p>	19-16	<p>RES</p> <p>Reserved locations. These locations should be read and written as zeros.</p>	
			15-12	<p>ONES</p> <p>These four bits must be written as ones. They are written by the host and unchanged by the Am79C978A controller.</p>	
			11-0	<p>BCNT</p> <p>Buffer Byte Count is the length of the buffer pointed to by this descriptor, expressed as the two's complement of the length of the buffer. This field is written by the host and unchanged by the Am79C978A controller.</p>	
RMD2					
			Bit	Name	Description
			31	ZERO	This field is reserved. The Am79C978A controller will write a zero to this location.
			30-16	RFRTAG	Receive Frame Tag. Indicates the Receive Frame Tag applied from the EADI interface. This field is user defined and has a default value of all zeros. When

RXFRTG (CSR7, bit 14) is set to 0, RFRTAG will be read as all zeros. See the section on *Receive Frame Tagging* for details.

15-12 ZEROS This field is reserved. The Am79C978A controller will write zeros to these locations.

11-0 MCNT Message Byte Count is the length in bytes of the received message, expressed as an unsigned binary integer. MCNT is valid only when ERR is clear and ENP is set. MCNT is written by the Am79C978A controller and cleared by the host.

RMD3

Bit	Name	Description
31-0	US	User Space. Reserved for user defined space.

Transmit Descriptors

When SWSTYLE (BCR20, bits 7-0) is set to 0, the software structures are defined to be 16 bits wide, and transmit descriptors look like Table 83 (CXDA = Current Transmit Descriptor Address).

When SWSTYLE (BCR 20, bits 7-0) is set to 2, the software structures are defined to be 32 bits wide, and transmit descriptors look like Table 84 (CXDA = Current Transmit Descriptor Address).

When SWSTYLE (BCR 20, bits 7-0) is set to 3, then the software structures are defined to be 32 bits wide, and transmit descriptors look like Table 85 (CXDA = Current Transmit Descriptor Address).

Table 83. Transmit Descriptor (SWSTYLE = 0)

Address	15	14	13	12	11	10	9	8	7-0
CXDA+00h	TBADR[15:0]								
CXDA+02h	OWN	ERR	ADD_FCS	MORE/LTINT	ONE	DEF	STP	ENP	TBADR[23:16]
CXDA+04h	1	1	1	1	BCNT				
CXDA+06h	BUFF	UFLO	EXDEF	LCOL	LCAR	RTRY	TDR		

Table 84. Transmit Descriptor (SWSTYLE = 2)

Address	31	30	29	28	27	26	25	24	23	22-16	15-12	11-4	3-0
CXDA+00h	TBADR[31:0]												
CXDA+04h	OWN	ERR	ADD_FCS	MORE/LTINT	ONE	DEF	STP	ENP	BPE	RES	1111	BCNT	
CXDA+08h	BUFF	UFLO	EXDEF	LCOL	LCAR	RTRY	RES	RES	RES	RES	RES	RES	TRC
CXDA+0Ch	USER SPACE												

Table 85. Transmit Descriptor (SWSTYLE = 3)

Address	31	30	29	28	27	26	25	24	23	22-16	15-12	11-4	3-0
CXDA+00h	BUFF	UFLO	EXDEF	LCOL	LCAR	RTRY	RES					RES	TRC
CXDA+04h	OWN	ERR	ADD_FCS	MORE/LTINT	ONE	DEF	STP	ENP	BPE	RES	1111	BCNT	
CXDA+08h	TBADR[31:0]												
CXDA+0Ch	USER SPACE												

TMD0

Bit	Name	Description
31-0	TBADR	Transmit Buffer address. This field contains the address of the transmit buffer that is associated with this descriptor.

TMD1

Bit	Name	Description
31	OWN	This bit indicates whether the descriptor entry is owned by the host (OWN = 0) or by the Am79C978A controller (OWN = 1). The host sets the OWN bit after filling the buffer pointed to by the descriptor entry. The Am79C978A controller clears the OWN bit after transmitting the contents of the buffer. Both the Am79C978A controller and the host must not alter a descriptor entry after it has relinquished ownership.
30	ERR	ERR is the OR of UFLO, LCOL, LCAR, RTRY or BPE. ERR is set by the Am79C978A controller and cleared by the host. This bit is set in the current descriptor when the error occurs and, therefore, may be set in any descriptor of a chained buffer transmission.
29	ADD_FCS	ADD_FCS dynamically controls the generation of FCS on a frame by frame basis. This bit should be set with the ENP bit. However, for backward compatibility, it is recommended that this bit be set for every descriptor of the intended frame. When ADD_FCS is set, the state of DXMTFCS is ignored and transmitter FCS generation is activated. When ADD_FCS is cleared to 0, FCS generation is controlled by DXMTFCS. When APAD_XMT (CSR4, bit 11) is set to 1, the setting of ADD_FCS has no effect. ADD_FCS is set by the host, and is not changed by the Am79C978A controller. This is a reserved bit in the C-LANCE (Am79C90) controller.

28 MORE/LTINT Bit 28 always functions as MORE. The value of MORE is written by the Am79C978A controller and is read by the host. When LTINTEN is cleared to 0 (CSR5, bit 14), the Am79C978A controller will never look at the contents of bit 28, write operations by the host have no effect. When LTINTEN is set to 1 bit 28 changes its function to LTINT on host write operations and on Am79C978A controller read operations.

MORE MORE indicates that more than one retry was needed to transmit a frame. The value of MORE is written by the Am79C978A controller. This bit has meaning only if the ENP bit is set.

LTINT LTINT is used to suppress interrupts after successful transmission on selected frames. When LTINT is cleared to 0 and ENP is set to 1, the Am79C978A controller will not set TINT (CSR0, bit 9) after a successful transmission. TINT will only be set when the last descriptor of a frame has both LTINT and ENP set to 1. When LTINT is cleared to 0, it will only cause the suppression of interrupts for successful transmission. TINT will always be set if the transmission has an error. The LTINTEN overrides the function of TOKINTD (CSR5, bit 15).

27 ONE ONE indicates that exactly one retry was needed to transmit a frame. ONE flag is not valid when LCOL is set. The value of the ONE bit is written by the Am79C978A controller. This bit has meaning only if the ENP bit is set.

26 DEF Deferred indicates that the Am79C978A controller had to defer while trying to transmit a frame. This condition occurs if the channel is busy when the Am79C978A controller is ready to transmit. DEF is set by the Am79C978A controller and cleared by the host.

25	STP	Start of Packet indicates that this is the first buffer to be used by the Am79C978A controller for this frame. It is used for data chaining buffers. The STP bit must be set in the first buffer of the frame, or the Am79C978A controller will skip over the descriptor and poll the next descriptor(s) until the OWN and STP bits are set. STP is set by the host and is not changed by the Am79C978A controller.	transmitted by the Am79C978A controller. This field is written by the host and is not changed by the Am79C978A controller. There are no minimum buffer size restrictions.
24	ENP	End of Packet. End of Packet indicates that this is the last buffer to be used by the Am79C978A controller for this frame. It is used for data chaining buffers. If both STP and ENP are set, the frame fits into one buffer and there is no data chaining. ENP is set by the host and is not changed by the Am79C978A controller.	
23	BPE	Bus Parity Error is set by the Am79C978A controller when a parity error occurred on the bus interface during a data transfers from the transmit buffer associated with this descriptor. The Am79C978A controller will only set BPE when the advanced parity error handling is enabled by setting APERREN (BCR20, bit 10) to 1. BPE is set by the Am79C978A controller and cleared by the host.	
		This bit does not exist, when the Am79C978A controller is programmed to use 16-bit software structures for the descriptor ring entries (BCR20, bits 7-0, SWSTYLE is cleared to 0).	
22-16	RES	Reserved locations.	
15-12	ONES	These four bits must be written as ones. This field is written by the host and unchanged by the Am79C978A controller.	
11-00	BCNT	Buffer Byte Count is the usable length of the buffer pointed to by this descriptor, expressed as the two's complement of the length of the buffer. This is the number of bytes from this buffer that will be	

TMD2		
Bit	Name	Description
31	BUFF	Buffer error is set by the Am79C978A controller during transmission when the Am79C978A controller does not find the ENP flag in the current descriptor and does not own the next descriptor. This can occur in either of two ways: <ol style="list-style-type: none"> 1. The OWN bit of the next buffer is 0. 2. FIFO underflow occurred before the Am79C978A controller obtained the STATUS byte (TMD1[31:24]) of the next descriptor. BUFF is set by the Am79C978A controller and cleared by the host. If a Buffer Error occurs, an Underflow Error will also occur. BUFF is set by the Am79C978A controller and cleared by the host.
30	UFLO	Underflow error indicates that the transmitter has truncated a message because it could not read data from memory fast enough. UFLO indicates that the FIFO has emptied before the end of the frame was reached. <p>When DXSUFLO (CSR3, bit 6) is cleared to 0, the transmitter is turned off when an UFLO error occurs (CSR0, TXON = 0).</p> <p>When DXSUFLO is set to 1, the Am79C978A controller gracefully recovers from an UFLO error. It scans the transmit descriptor ring until it finds the start of a new frame and starts a new transmission.</p> UFLO is set by the Am79C978A controller and cleared by the host.

29	EXDEF	Excessive Deferral. Indicates that the transmitter has experienced Excessive Deferral on this transmit frame, where Excessive Deferral is defined in the ISO 8802-3 (IEEE/ANSI 802.3) standard. Excessive Deferral will also set the interrupt bit EXDINT (CSR5, bit 7).	26	RTRY	LCAR will be set when the PHY is in Link Fail state during transmission. Retry error indicates that the transmitter has failed after 16 attempts to successfully transmit a message, due to repeated collisions on the medium. If DRTY is set to 1 in the MODE register, RTRY will set after one failed transmission attempt. RTRY is set by the Am79C978A controller and cleared by the host.
28	LCOL	Late Collision indicates that a collision has occurred after the first channel slot time has elapsed. The Am79C978A home networking Am79C978A controller does not retry on late collisions. LCOL is set by the Am79C978A controller and cleared by the host.	25-4	RES	Reserved locations.
27	LCAR	Loss of Carrier is set when the carrier is lost during an Am79C978A controller initiated transmission when operating in half-duplex mode. The Am79C978A controller does not retry upon loss of carrier. It will continue to transmit the whole frame until done. LCAR will not be set when the device is operating in full-duplex mode. LCAR is not valid in Internal Loopback Mode. LCAR is set by the Am79C978A controller and cleared by the host.	3-0	TRC	Transmit Retry Count. Indicates the number of transmit retries of the associated packet. The maximum count is 15. However, if a RETRY error occurs, the count will roll over to 0. In this case only, the Transmit Retry Count value of 0 should be interpreted as meaning 16. TRC is written by the Am79C978A controller into the last transmit descriptor of a frame, or when an error terminates a frame. Valid only when OWN is cleared to 0.

TMD3

Bit	Name	Description
31-0	US	User Space. Reserved for user defined space.

REGISTER SUMMARY

PCI Configuration Registers

Table 86. PCI Configuration Registers

Offset	Name	Width in Bit	Access Mode	Default Value
00h	PCI Vendor ID	16	RO	1022h
02h	PCI Device ID	16	RO	2001h
04h	PCI Command	16	RW	0000h
06h	PCI Status	16	RW	0290h
08h	PCI Revision ID	8	RO	52h
09h	PCI Programming IF	8	RO	00h
0Ah	PCI Sub-Class	8	RO	00h
0Bh	PCI Base-Class	8	RO	02h
0Ch	Reserved	8	RO	00h
0Dh	PCI Latency Timer	8	RW	00h
0Eh	PCI Header Type	8	RO	00h
0Fh	Reserved	8	RO	00h
10h	PCI I/O Base Address	32	RW	0000 0001h
14h	PCI Memory Mapped I/O Base Address	32	RW	0000 0000h
18h - 2Bh	Reserved	8	RO	00h
2Ch	PCI Subsystem Vendor ID	16	RO	00h
2Eh	PCI Subsystem ID	16	RO	00h
30h	PCI Expansion ROM Base Address	32	RW	0000 0000h
34h	Capabilities Pointer	8	RO	40h
31h - 3Bh	Reserved	8	RO	00h
3Ch	PCI Interrupt Line	8	RW	00h
3Dh	PCI Interrupt Pin	8	RO	01h
3Eh	PCI MIN_GNT	8	RO	06h
3Fh	PCI MAX_LAT	8	RO	FFh
40h	PCI Capability Identifier	8	RO	01h
41h	PCI Next Item Pointer	8	RO	00h
42h	PCI Power Management Capabilities	16	RO	00h
44h	PCI Power Management Control/Status	16	RO	00h
46h	PCI PMCSR Bridge Support Extensions	8	RO	00h
47h	PCI Data	8	RO	00h
48h - FFh	Reserved	8	RO	00h

Note: RO = read only, RW = read/write

Control and Status Registers

RAP Addr	Symbol	Default Value	Comments	Use
00	CSR0	uuuu 0004	Am79C978A Controller Status Register	R
01	CSR1	uuuu uuuu	Lower IADR: Maps to location 16	S
02	CSR2	uuuu uuuu	Upper IADR: Maps to location 17	S
03	CSR3	uuuu 0000	Interrupt Masks and Deferral Control	S
04	CSR4	uuuu 0115	Test and Features Control	R
05	CSR5	uuuu 0000	Extended Control and Interrupt 1	R
06	CSR6	uuuu uuuu	RXTX: RX/TX Encoded Ring Lengths	S
07	CSR7	0uuu 0000	Extended Control and Interrupt 1	R
08	CSR8	uuuu uuuu	LADRF0: Logical Address Filter — LADRF[15:0]	S
09	CSR9	uuuu uuuu	LADRF1: Logical Address Filter — LADRF[31:16]	S
10	CSR10	uuuu uuuu	LADRF2: Logical Address Filter — LADRF[47:32]	S
11	CSR11	uuuu uuuu	LADRF3: Logical Address Filter — LADRF[63:48]	S
12	CSR12	uuuu uuuu	PADR0: Physical Address Register — PADR[15:0][S
13	CSR13	uuuu uuuu	PADR1: Physical Address Register — PADR[31:16]	S
14	CSR14	uuuu uuuu	PADR2: Physical Address Register — PADR[47:32]	S
15	CSR15	See register description	MODE: Mode Register	S
16	CSR16	uuuu uuuu	IADRL: Base Address of INIT Block Lower (Copy)	T
17	CSR17	uuuu uuuu	IADRH: Base Address of INIT Block Upper (Copy)	T
18	CSR18	uuuu uuuu	CRBAL: Current RCV Buffer Address Lower	T
19	CSR22	uuuu uuuu	CRBAU: Current RCV Buffer Address Upper	T
20	CSR20	uuuu uuuu	CXBAL: Current XMT Buffer Address Lower	T
21	CSR21	uuuu uuuu	CXBAU: Current XMT Buffer Address Upper	T
22	CSR22	uuuu uuuu	NRBAL: Next RCV Buffer Address Lower	T
23	CSR23	uuuu uuuu	NRBAU: Next RCV Buffer Address Upper	T
24	CSR24	uuuu uuuu	BADRL: Base Address of RCV Ring Lower	S
25	CSR25	uuuu uuuu	BADRU: Base Address of RCV Ring Upper	S
26	CSR26	uuuu uuuu	NRDAL: Next RCV Descriptor Address Lower	T
27	CSR27	uuuu uuuu	NRDAU: Next RCV Descriptor Address Upper	T
28	CSR28	uuuu uuuu	CRDAL: Current RCV Descriptor Address Lower	T
29	CSR29	uuuu uuuu	CRDAU: Current RCV Descriptor Address Upper	T
30	CSR30	uuuu uuuu	BADXL: Base Address of XMT Ring Lower	S
31	CSR31	uuuu uuuu	BADXU: Base Address of XMT Ring Upper	S
32	CSR32	uuuu uuuu	NXDAL: Next XMT Descriptor Address Lower	T
33	CSR33	uuuu uuuu	NXDAU: Next XMT Descriptor Address Upper	T

Note:

u = undefined value, R = Running register, S = Setup register, T = Test register; all default values are in hexadecimal format.

Control and Status Registers (Continued)

RAP Addr	Symbol	Default Value After H_RESET	Comments	Use
34	CSR34	uuuu uuuu	CXDAL: Current XMT Descriptor Address Lower	T
35	CSR35	uuuu uuuu	CXDAU: Current XMT Descriptor Address Upper	T
36	CSR36	uuuu uuuu	NNRDAL: Next Next Receive Descriptor Address Lower	T
37	CSR37	uuuu uuuu	NNRDAU: Next Next Receive Descriptor Address Upper	T
38	CSR38	uuuu uuuu	NNXDAL: Next Next Transmit Descriptor Address Lower	T
39	CSR39	uuuu uuuu	NNXDAU: Next Next Transmit Descriptor Address Upper	T
40	CSR40	uuuu uuuu	CRBC: Current Receive Byte Count	T
41	CSR41	uuuu uuuu	CRST: Current Receive Status	T
42	CSR42	uuuu uuuu	CXBC: Current Transmit Byte	T
43	CSR43	uuuu uuuu	CXST: Current Transmit Status	T
44	CSR44	uuuu uuuu	NRBC: Next RCV Byte Count	T
45	CSR45	uuuu uuuu	NRST: Next RCV Status	T
46	CSR46	uuuu uuuu	POLL: Poll Time Counter	T
47	CSR47	uuuu uuuu	PI: Polling Interval	S
48	CSR48	uuuu uuuu	Reserved	
49	CSR49	uuuu uuuu	Reserved	
50	CSR50	uuuu uuuu	Reserved	
51	CSR51	uuuu uuuu	Reserved	
52	CSR52	uuuu uuuu	Reserved	
53	CSR53	uuuu uuuu	Reserved	
54	CSR54	uuuu uuuu	Reserved	
55	CSR55	uuuu uuuu	Reserved	
56	CSR56	uuuu uuuu	Reserved	
57	CSR57	uuuu uuuu	Reserved	
58	CSR58	See register description	SWS: Software Style	S
59	CSR59	uuuu uuuu	Reserved	T
60	CSR60	uuuu uuuu	PXDAL: Previous XMT Descriptor Address Lower	T
61	CSR61	uuuu uuuu	PXDAU: Previous XMT Descriptor Address Upper	T
62	CSR62	uuuu uuuu	PXBC: Previous Transmit Byte Count	T
63	CSR63	uuuu uuuu	PXST: Previous Transmit Status	T
64	CSR64	uuuu uuuu	NXBAL: Next XMT Buffer Address Lower	T
65	CSR65	uuuu uuuu	NXBAU: Next XMT Buffer Address Upper	T
66	CSR66	uuuu uuuu	NXBC: Next Transmit Byte Count	T
67	CSR67	uuuu uuuu	NXST: Next Transmit Status	T
68	CSR68	uuuu uuuu	Reserved	
69	CSR69	uuuu uuuu	Reserved	
70	CSR70	uuuu uuuu	Reserved	

Control and Status Registers (Continued)

RAP Addr	Symbol	Default Value After H_RESET	Comments	Use
71	CSR71	uuuu uuuu	Reserved	
72	CSR72	uuuu uuuu	RCVRC: RCV Ring Counter	T
73	CSR73	uuuu uuuu	Reserved	
74	CSR74	uuuu uuuu	XMTRC: XMT Ring Counter	T
75	CSR75	uuuu uuuu	Reserved	
76	CSR76	uuuu uuuu	RCVRL: RCV Ring Length	S
77	CSR77	uuuu uuuu	Reserved	
78	CSR78	uuuu uuuu	XMTRL: XMT Ring Length	S
79	CSR79	uuuu uuuu	Reserved	
80	CSR80	uuuu 1410	DMATCFW: DMA Transfer Counter and FIFO Threshold	S
81	CSR81	uuuu uuuu	Reserved	
82	CSR82	uuuu uuuu	Transmit Descriptor Pointer Address Lower	S
83	CSR83	uuuu uuuu	Reserved	
84	CSR84	uuuu uuuu	DMABA: Address Register Lower	T
85	CSR85	uuuu uuuu	DMABA: Address Register Upper	T
86	CSR86	uuuu uuuu	DMABC: Buffer Byte Counter	T
87	CSR87	uuuu uuuu	Reserved	
88	CSR88	262 5003	Chip ID Register Lower	T
89	CSR89	uuuu 262	Chip ID Register Upper	T
90	CSR90	uuuu uuuu	Reserved	
91	CSR91	uuuu uuuu	Reserved	T
92	CSR92	uuuu uuuu	RCON: Ring Length Conversion	T
93	CSR93	uuuu uuuu	Reserved	
94	CSR94	uuuu uuuu	Reserved	
95	CSR95	uuuu uuuu	Reserved	
96	CSR96	uuuu uuuu	Reserved	
97	CSR97	uuuu uuuu	Reserved	
98	CSR98	uuuu uuuu	Reserved	
99	CSR99	uuuu uuuu	Reserved	
100	CSR100	uuuu 0200	Bus Timeout	S
101	CSR101	uuuu uuuu	Reserved	
102	CSR102	uuuu uuuu	Reserved	
103	CSR103	uuuu 0105	Reserved	
104	CSR104	uuuu uuuu	Reserved	
105	CSR105	uuuu uuuu	Reserved	
106	CSR106	uuuu uuuu	Reserved	
107	CSR107	uuuu uuuu	Reserved	

Control and Status Registers (Concluded)

RAP Addr	Symbol	Default Value After H_RESET	Comments	Use
108	CSR108	uuuu uuuu	Reserved	
109	CSR109	uuuu uuuu	Reserved	
110	CSR110	uuuu uuuu	Reserved	
111	CSR111	uuuu uuuu	Reserved	
112	CSR112	uuuu uuuu	Missed Frame Count	R
113	CSR113	uuuu uuuu	Reserved	
114	CSR114	uuuu uuuu	Received Collision Count	R
115	CSR115	uuuu uuuu	Reserved	
116	CSR116	0000 0000	OnNow Miscellaneous	S
117	CSR117	uuuu uuuu	Reserved	
118	CSR118	uuuu uuuu	Reserved	
119	CSR119	uuuu 0105	Reserved	
120	CSR120	uuuu uuuu	Reserved	
121	CSR121	uuuu uuuu	Reserved	
122	CSR226	uuuu 0000	Receive Frame Alignment Control	S
123	CSR237	uuuu uuuu	Reserved	
124	CSR248	uuuu 0000	Test Register 1	T
125	CSR125	003c 0060	MAC Enhanced Configuration Control	T
126	CSR126	uuuu uuuu	Reserved	
127	CSR127	uuuu uuuu	Reserved	

Bus Configuration Registers

Writes to those registers marked as “Reserved” will have no effect. Reads from these locations will produce undefined values.

RAP	Mnemonic	Default	Name	Programmability	
				User	EEPROM
0	MSRDA	0005h	Reserved	No	No
1	MSWRA	0005h	Reserved	No	No
2	MC	0002h	Miscellaneous Configuration	Yes	Yes
3	Reserved	N/A	Reserved	No	No
4	LED0	00C0h	LED0 Status	Yes	Yes
5	LED1	0084h	LED1 Status	Yes	Yes
6	LED2	0088h	LED2 Status	Yes	Yes
7	LED3	0090h	LED3 Status	Yes	Yes
8	Reserved	N/A	Reserved	No	No
9	FDC	0000h	Full-Duplex Control	Yes	Yes
10-15	Reserved	N/A	Reserved	No	No
16	IOBASEL	N/A	Reserved	No	No
17	IOBASEU	N/A	Reserved	No	No
18	BSBC	9001h	Burst and Bus Control	Yes	Yes
19	EECAS	0002h	EEPROM Control and Status	Yes	No
20	SWS	0200h	Software Style	Yes	No
22	PCILAT	FF06h	PCI Latency	Yes	Yes
23	PCISID	0000h	PCI Subsystem ID	No	Yes
24	PCISVID	0000h	PCI Subsystem Vendor ID	No	Yes
25	SRAMSIZ	0000h	SRAM Size	Yes	Yes
26	SRAMB	0000h	SRAM Boundary	Yes	Yes
27	SRAMIC	0000h	SRAM Interface Control	Yes	Yes
28	EBADDRL	N/A	Expansion Bus Address Lower	Yes	No
29	EBADDRU	N/A	Expansion Bus Address Upper	Yes	No
30	EBDR	N/A	Expansion Bus Data Port	Yes	No
31	STVAL	FFFFh	Software Timer Value	Yes	No
32	MIICAS	0000h	PHY Control and Status	Yes	Yes
33	MIIADDR	N/A	PHY Address	Yes	Yes
34	MIIMDR	N/A	PHY Management Data	Yes	No
35	PCIVID	1022h	PCI Vendor ID	No	Yes
36	PMC_A	C811h	PCI Power Management Capabilities (PMC) Alias Register	No	Yes
37	DATA0	0000h	PCI DATA Register Zero Alias Register	No	Yes
38	DATA1	0000h	PCI DATA Register One Alias Register	No	Yes
39	DATA2	0000h	PCI DATA Register Two Alias Register	No	Yes
40	DATA3	0000h	PCI DATA Register Three Alias Register	No	Yes
41	DATA4	0000h	PCI DATA Register Four Alias Register	No	Yes
42	DATA5	0000h	PCI DATA Register Five Alias Register	No	Yes
43	DATA6	0000h	PCI DATA Register Six Alias Register	No	Yes
44	DATA7	0000h	PCI DATA Register Seven Alias Register	No	Yes
45	PMR1	N/A	Pattern Matching Register 1	Yes	No
46	PMR2	N/A	Pattern Matching Register 2	Yes	No
47	PMR3	N/A	Pattern Matching Register 3	Yes	No
48	LED4	0082h	LED4 Status	Yes	Yes
49	PHY_SEL	8000h	PHY Select	Yes	Yes

10BASE-T PHY Management Registers

Writes to registers marked “Reserved” will be written as zeros. Reads from these locations will produce undefined values.

Table 87. 10BASE-T PHY Management Registers (TBRs)

Register Address	Symbol	Name	Default Value After H_RESET
0	TBR0	PHY Control Register	1500h
1	TBR1	PHY Status Register	1849h
2	TBR2	PHY_ID[31:16]	0000h
3	TBR3	PHY_ID[15:0]	6670h
4	TBR4	Auto-Negotiation Advertisement Register	0061h
5	TBR5	Auto-Negotiation Link Partner Ability Register	0000h
6	TBR6	Auto-Negotiation Expansion Register	0004h
7	TBR7	Auto-Negotiation Next Page Register	2001h
8-15	TBR8-TBR15	Reserved	–{
16	TBR16	Interrupt Status and Enable Register	0000h
17	TBR17	PHY Control/Status Register	0001h
18	TBR18	Reserved	–
19	TBR19	PHY Management Extension Register	–
20-23	TBR20-TBR23	Reserved	–
24	TBR24	Summary Status Register	0001h
25-31	TBR25-TBR31	Reserved	–

1 Mbps HomePNA PHY Management Registers

Table 88. 1 Mbps HomePNA PHY Management Registers (HPRs)

Register Address	Symbol	Name	Default Value After H_RESET
0	HPR0	MII Control Register	0400h
1	HPR1	MII Status Register	0841h
2	HPR2	MII PHY_ID Register	0000h
3	HPR3	MII PHY_ID Register	6B90h
4	HPR4	Auto-Negotiation Register	0021h
5	HPR5	Auto-Negotiation Register	0000h
6	HPR6	Auto-Negotiation Register	0000h
7	HPR7	Auto-Negotiation Register	0000h
8-15	HPR8-HPR15	Reserved	–
16	HPR16	PHY Control Register	0005h
17	HPR17	Reserved	–
18	HPR18	PHY TXCOMM Register	0000h
19	HPR19	PHY TXCOMM Register	0000h
20	HPR20	PHY RXCOMM Register	0000h
21	HPR21	PHY RXCOMM Register	0000h
22	HPR22	PHY AID Register	0000h
23	HPR23	PHY Noise Control Register	03FFh
24	HPR24	PHY Noise Control 2 Register	F4xxh
25	HPR25	PHY Noise Statistics Register	03FFh
26	HPR26	Event Status Register	0000h
27	HPR27	AID Control Register	1440h
28	HPR28	ISBI Control Register	2C1Ch
29	HPR29	TX Control Register	0444h
30-31	HPR30-HPR31	Reserved	–

REGISTER PROGRAMMING SUMMARY

Am79C978A Programmable Registers

Table 89. Control and Status Registers

Register	Contents			
CSR0	Status and control bits: (DEFAULT = 0004)			
	8000 ERR 4000 -- 2000 CERR 1000 MISS	0800 MERR 0400 RINT 0200 TINT 0100I IDON	0080 INTR 0040 IENA 0020 RXON 0010 TXON	0008 TDMD 0004 STOP 0002 STRT 0001 INIT
CSR1	Lower IADR (Maps to CSR 16)			
CSR2	Upper IADR (Maps to CSR 17)			
CSR3	Interrupt masks and Deferral Control: (DEFAULT = 0)			
	8000 -- 4000 -- 2000 -- 1000 MISSM	0800 MERRM 0400 RINTM 0200 TINTM 0100 IDONM	0080 -- 0040 DXSUFLO 0020 LAPPEN 0010 DXMT2PD	0008 EMBA 0004 BSWP 0002 -- 0001 --
CSR4	Interrupt masks, configuration and status bits: (DEFAULT = 0115)			
	8000 -- 4000 DMAPLUS 2000 -- 1000 TXDPOLL	0800 APAD_XMT 0400 ASTRP_RCV 0200 MFCO 0100 MFCOM	0080 UNITCMD 0040 UNIT 0020 RCVCCO 0010 RCVCCOM	0008 TXSTRT 0004 TXSTRTM 0002 -- 0001 --
CSR5	Extended Interrupt masks, configuration and status bits: (DEFAULT = 0XXX)			
	8000 TOKINTD 4000 LTINTEN 2000 -- 1000 --	0800 SINT 0400 SINTE 0200 -- 0100 --	0080 EXDINT 0040 EXDINTE 0020 MPPLBA 0010 MPINT	0008 MPINTE 0004 MPEN 0002 MPMODE 0001 SPND
CSR7	Extended Interrupt masks, configuration and status bits: (DEFAULT = 0000)			
	8000 FASTSPND 4000 RXFRMTG 2000 RDMD 1000 RXDPOLL	0800 STINT 0400 STINTE 0200 MREINT 0100 MREINTE	0080 MAPINT 0040 MAPINTE 0020 MCCINT 0010 MCCINTE	0008 MCCIINT 0004 MCCIINTE 0002 MIIPDTINT 0001 MIIPDTNTE
CSR8 - CSR11	Logical Address Filter			
CSR12 - CSR14	Physical Address Register			
CSR15	MODE: (DEFAULT = 0) bits [8:7] = PORTSEL, Port Selection 11 PHY Selected 10 Reserved			
	8000 PROM 4000 DRCVBC 2000 DRCVPA 1000 --	0800 -- 0400 -- 0200 -- 0100 PORTSEL1	0080 PORTSEL0 0040 INTL 0020 DRTY 0010 FCOLL	0008 DXMTFCS 0004 LOOP 0002 DTX 0001 DRX
CSR47	TXPOLLINT: Transmit Polling Interval			
CSR49	RXPOLLINT: Receive Polling Interval			
CSR58	Software Style (mapped to BCR20) bits [7:0] = SWSTYLE, Software Style Register. 0000 LANCE/PCnet-ISA 0002 PCnet-32			
	8000 -- 4000 -- 2000 -- 1000 --	0800 -- 0400 APERREN 0200 -- 0100 SSIZE32	0080 -- 0040 -- 0020 -- 0010 --	0008 SWSTYLE3 0004 SWSTYLE2 0002 -- 0001 SWSTYLE0

Am79C978A Programmable Registers (Continued)

Register	Contents				
CSR76	RCVRL: RCV Descriptor Ring length				
CSR78	XMTRL: XMT Descriptor Ring length				
CSR80	FIFO threshold and DMA burst control (DEFAULT = 2810)				
	8000 Reserved 4000 Reserved bits [13:12] = RCVFW, Receive FIFO Watermark 0000 Request DMA when 16 bytes are present 1000 Request DMA when 64 bytes are present 2000 Request DMA when 112 bytes are present 3000 Reserved bits [11:10] = XMTSP, Transmit Start Point 0000 Start transmission after 20/36 (No SRAM/SRAM) bytes have been written 0400 Start transmission after 64 bytes have been written 0800 Start transmission after 128 bytes have been written 0C00 Start transmission after 220 max/Full Packet (No SRAM/SRAM with UFLO bit set) bytes have been written bits [9:8] = XMTFW, Transmit FIFO Watermark 0000 Start DMA when 16 write cycles can be made 0100 Start DMA when 32 write cycles can be made 0200 Start DMA when 64 write cycles can be made 0300 Start DMA when 128 write cycles can be made bits [7:0] = DMA Burst Register				
CSR88~89	Chip ID (Contents = v2626003; v = Version Number)				
CSR112	Missed Frame Count				
CSR114	Receive Collision Count				
CSR116	OnNow Miscellaneous				
	8000 –	0800 –	0080 PMAT	0008 RWU_DRIVER	
	4000 –	0400 –	0040 EMPPLBA	0004 RWU_GATE	
	2000 –	0200 PME_EN_OVR	0020 MPMAT	0002 RWU_POL	
	1000 –	0100 LCDET	0010 MPPEN	0001 RST_POL	
CSR122	Receive Frame Alignment Control				
	8000 –	0800 –	0080 –	0008 –	
	4000 –	0400 –	0040 –	0004 –	
	2000 –	0200 –	0020 –	0002 –	
	1000 –	0100 –	0010 –	0001 RCVALGN	
CSR124	BMU Test Register (DEFAULT = 0000)				
	8000 –	0800 –	0080 –	0008 –	
	4000 –	0400 –	0040 –	0004 RPA	
	2000 –	0200 –	0020 –	0002 –	
	1000 –	0100 –	0010 –	0001 –	
CSR125	MAC Enhanced Configuration Control (DEFAULT = 603c)				
	bits [15:8] = IPG, InterPacket Gap (Default = 60xx, 96 bit times)				
	bits [8:0] = IFS1, InterFrame Space Part 1 (Default = xx3c, 60 bit times)				

Am79C978A Programmable Registers (Continued)

Table 90. Bus Configuration Registers

RAP Addr	Register	Contents							
0	MSRDA	Programs width of DMA read signal (DEFAULT = 5)							
1	MSWRA	Programs width of DMA write signal (DEFAULT = 5)							
2	MC	Miscellaneous Configuration bits: (DEFAULT = 2)							
		8000	–	0800	–	0080	INITLEVEL	0008	EADISEL
		4000	–	0400	–	0040	–	0004	–
		2000	–	0200	–	0020	–	0002	ASEL 0001
		1000	–	0100	APROMWE	0010	–	–	–
4	LED0	Programs the function and width of the LED0 signal. (DEFAULT = 00C0)							
		8000	LEDOUT	0800	–	0080	PSE	0008	POWER
		4000	LEDPOL	0400	–	0040	LNKSE	0004	RCVE
		2000	LEDDIS	0200	MPSE	0020	RCVME	0002	SPEED
		1000	100E	0100	FDLSE	0010	XMTE	0001	COLE
5	LED1	Programs the function and width of the LED1 signal. (DEFAULT = 0084)							
		8000	LEDOUT	0800	–	0080	PSE	0008	POWER
		4000	LEDPOL	0400	–	0040	LNKSE	0004	RCVE
		2000	LEDDIS	0200	MPSE	0020	RCVME	0002	SPEED
		1000	100E	0100	FDLSE	0010	XMTE	0001	COLE
6	LED2	Programs the function and width of the LED2 signal. (DEFAULT = 0088)							
		8000	LEDOUT	0800	–	0080	PSE	0008	POWER
		4000	LEDPOL	0400	–	0040	LNKSE	0004	RCVE
		2000	LEDDIS	0200	MPSE	0020	RCVME	0002	SPEED
		1000	100E	0100	FDLSE	0010	XMTE	0001	COLE
7	LED3	Programs the function and width of the LED3 signal. (DEFAULT = 0090)							
		8000	LEDOUT	0800	–	0080	PSE	0008	POWER
		4000	LEDPOL	0400	–	0040	LNKSE	0004	RCVE
		2000	LEDDIS	0200	MPSE	0020	RCVME	0002	SPEED
		1000	100E	0100	FDLSE	0010	XMTE	0001	COLE
9	FDC	Full-Duplex Control. (DEFAULT = 0000)							
		8000	–	0800	–	0080	–	0008	–
		4000	–	0400	–	0040	–	0004	FDRPAD
		2000	–	0200	–	0020	–	0002	–
		1000	–	0100	–	0010	–	0001	FDEN
16	IOBASEL	I/O Base Address Lower							
17	IOBASEU	I/O Base Address Upper							
18	BSBC	Burst Size and Bus Control (DEFAULT = 2101)							
		8000	ROMTMG3	0800	NOUFLO	0080	DWIO	0008	–
		4000	ROMTMG2	0400	–	0040	BREADE	0004	–
		2000	ROMTMG1	0200	MEMCMD	0020	BWRITE	0002	–
		1000	ROMTMG0	0100	EXTREQ	0010	–	0001	–
19	EECAS	EEPROM Control and Status (DEFAULT = 0002)							
		8000	PVALID	0800	–	0080	–	0008	–
		4000	PREAD	0400	–	0040	–	0004	ECS
		2000	EEDET	0200	–	0020	–	0002	ESK
		1000	–	0100	–	0010	EEN	0001	EDI/EDO
20	SWSTYLE	Software Style (DEFAULT = 0000, maps to CSR 58)							

Am79C978A Programmable Registers (Continued)

RAP Addr	Register	Contents							
22	PCILAT	PCI Latency (DEFAULT = FF06)							
		bits [15:8] = MAX_LAT bits [7:0] = MIN_GNT							
25	SRAMSIZE	SRAM Size (DEFAULT = 0000)							
		bits [7:0] = SRAM_SIZE							
26	SRAMBND	SRAM Boundary (DEFAULT = 0000)							
		bits [7:0] = SRAM_BND							
27	SRAMIC	SRAM Interface Control (Default = 0000)							
		8000PTR TST 4000LOLATRX bits [5:3] = EBCS, Expansion Bus Clock Source 0000 CLK pin, PCI clock 0008 Time Base Clock 0010 EBCLK pin, Expansion Bus Clock bits [2:0] = CLK_FAC, Expansion Bus Clock Factor 0000 1/1 clock factor 0001 1/2 clock factor 0002 – 0003 –							
28	EPADDRL	Expansion Port Address Lower (Default = 0000)							
29	EPADDRU	Expansion Port Address Upper (Default = 0000)							
		8000	FLASH	0800	–	0080	–	0008	EPADDRU3
		4000	LAINC	0400	–	0040	–	0004	EPADDRU2
		2000	–	0200	–	0020	–	0002	EPADDRU1
		1000	–	0100	–	0010	–	0001	EPADDRU0
30	EBDATA	Expansion Bus Data Port							
31	STVAL	Software Timer Interrupt Value (DEFAULT = FFFF)							
32	MIICAS	PHY Status and Control (DEFAULT = 0000)							
		8000	ANTST	0800	APEP	0080	DANAS	0008	XPHYSP
		4000	MIIPD	0400	APDW2	0040	XPHYRST	0004	–
		2000	FMDC1	0200	APDW1	0020	XPHYANE	0002	MIILP
		1000	FMDC0	0100	APDW0	0010	XPHYFD	0001	–
33	MIIADDR	PHY Address (DEFAULT = 0000)							
		bits [9:5] = PHYAD, Physical Layer Device Address bits [4:0] = REGAD, Auto-Negotiation Register Address							
34	MIIMDR	PHY Data Port							
35	PCI Vendor ID	PCI Vendor ID Register (DEFAULT = 1022h)							
36	PMC Alias	PCI Power Management Capabilities (DEFAULT = 0000)							
37	DATA 0	PCI Data Register Zero Alias Register (DEFAULT = 0000)							
38	DATA 1	PCI Data Register One Alias Register (DEFAULT = 0000)							
39	DATA 2	PCI Data Register Two Alias Register (DEFAULT = 0000)							
40	DATA 3	PCI Data Register Three Alias Register (DEFAULT = 0000)							
41	DATA 4	PCI Data Register Four Alias Register (DEFAULT = 0000)							
42	DATA 5	PCI Data Register Five Alias Register (DEFAULT = 0000)							
43	DATA 6	PCI Data Register Six Alias Register (DEFAULT = 0000)							
44	DATA 7	PCI Data Register Seven Alias Register (DEFAULT = 0000)							
45	PMR 1	OnNow Pattern Matching Register 1							
46	PMR 2	OnNow Pattern Matching Register 2							
47	PMR 3	OnNow Pattern Matching Register 3							

Am79C978A Programmable Registers (Continued)

RAP Addr	Register	Contents							
48	LED4	Programs the function and width of the LED3 signal. (DEFAULT = 0082)							
		8000	LEDOUT	0800	–	0080	PSE	0008	POWER
		4000	LEDPOL	0400	–	0040	LNKSE	0004	RCVE
		2000	LEDDIS	0200	MPSE	0020	RCVME	0002	SPEED
		1000	100E	0100	FDLSE	0010	XMTE	0001	COLE
49	PHY_SEL	PHY Select							
		8000	10BASE_T PHY						
		8101	HomeRun PHY						
		8202	External PHY						

ABSOLUTE MAXIMUM RATINGS

Storage Temperature -65°C to $+150^{\circ}\text{C}$

Ambient Temperature -65°C to $+70^{\circ}\text{C}$

Supply voltage

with respect to V_{SSB} , V_{SS} -0.3 V to 3.63 V

Stresses above those listed under Absolute Maximum Ratings may cause permanent device failure. Functionality at or above these limits is not implied. Exposure to Absolute Maximum Ratings for extended periods may affect device reliability.

OPERATING RANGES

Commercial (C) Devices

Temperature (TA) 0°C to $+70^{\circ}\text{C}$

Supply Voltages

(V_{DD} , V_{DDR} , V_{DD_PCI}) $+3.3\text{ V} \pm 10\%$

All inputs within the range: $V_{SS} - 0.5\text{ V}$ to 5.5 V

Operating ranges define those limits between which the functionality of the device is guaranteed.

DC CHARACTERISTICS OVER COMMERCIAL OPERATING RANGES unless otherwise specified

Parameter Symbol	Parameter Description	Test Conditions	Min	Max	Units
Digital I/O (Non-PCI Pins)					
V_{IH}	Input HIGH Voltage		2.0		V
V_{IL}	Input LOW Voltage			0.8	V
V_{OL}	Output LOW Voltage	$I_{OL1} = 4\text{ mA}$ $I_{OL2} = 6\text{ mA}$ $I_{OL3} = 12\text{ mA}$ (Note 1)		0.4	V
V_{OH}	Output HIGH Voltage (Notes 2, 3)	$I_{OH1} = -4\text{ mA}$ $I_{OH2} = -2\text{ mA}$ (Note 3)	2.4		V
I_{OZ}	Output Leakage Current (Note 4)	$0\text{ V} < V_{OUT} < V_{DD}$	-10	10	μA
I_{IX}	Input Leakage Current (Note 5)	$0\text{ V} < V_{IN} < V_{DD}$	-10	10	μA
I_{IL}	Input LOW Current (Note 6)	$V_{IN} = 0\text{ V}$; $V_{DD} = 3.6\text{ V}$	-200	-10	μA
I_{IH}	Input HIGH Current (Note 6)	$V_{IN} = 2.7\text{ V}$; $V_{DD} = 3.6\text{ V}$	-50	10	μA
PCI Bus Interface - 5 V Signaling					
V_{IH}	Input HIGH Voltage		2.0	5.5	V
V_{IL}	Input LOW Voltage		-0.5	0.8	V
I_{OZ}	Output Leakage Current (Note 4)	$0\text{ V} < V_{IN} < V_{DD_PCI}$	-10	10	μA
I_{IL}	Input LOW Current	$V_{IN} = 0.5\text{ V}$	-	-70	μA
I_{IH}	Input HIGH Current	$V_{IN} = 2.7\text{ V}$	-	70	μA
I_{IX_PME}	Input Leakage Current (Note 7)	$0\text{ V} < V_{IN} < 5.5\text{ V}$	-1	1	μA
V_{OH}	Output HIGH Voltage (Note 2)	$I_{OH} = -2\text{ mA}$	2.4		V
V_{OL}	Output LOW Voltage	$I_{OL4} = 3\text{ mA}$ $I_{OL2} = 6\text{ mA}$ (Note 1)		0.55	V
PCI Bus Interface - 3.3 V Signaling					
V_{IH}	Input HIGH Voltage		$0.5 V_{DD_PCI}$	$V_{DD_PCI} + 0.5$	V
V_{IL}	Input LOW Voltage		-0.5	$0.3 V_{DD_PCI}$	V
I_{OZ}	Output Leakage Current (Note 4)	$0\text{ V} < V_{OUT} < V_{DD_PCI}$	-10	10	μA
I_{IL}	Input HIGH Current	$0\text{ V} < V_{IN} < V_{DD_PCI}$	-10	10	μA
I_{IX_PME}	Input Leakage Current (Note 7)	$0\text{ V} < V_{IN} < 5.5\text{ V}$	-1	1	μA
V_{OH}	Output HIGH Voltage (Note 2)	$I_{OH} = -500\text{ }\mu\text{A}$	2.4		V
V_{OL}	Output LOW Voltage	$I_{OL} = 1500\text{ }\mu\text{A}$		$0.1 V_{DD_PCI}$	V

DC CHARACTERISTICS OVER COMMERCIAL OPERATING RANGES unless otherwise specified (Continued)

Parameter Symbol	Parameter Description	Test Conditions	Min	Max	Units
Pin Capacitance					
C_{IN}	Pin Capacitance	$F_C = 1$ MHz (Note 8)		10	pF
C_{CLK}	CLK Pin Capacitance	$F_C = 1$ MHz (Notes 8,9)	5	12	pF
C_{IDSEL}	IDSEL Pin Capacitance	$F_C = 1$ MHz (Notes 8, 10)		8	pF
LPIN	Pin Inductance	$F_C = 1$ MHz (Note 8)		20	nH
Power Supply Current (Note 11)					
I_{DD}	Dynamic Current	PCI CLK at 33 MHz		300	mA
I_{DD_WU1}	Wake-up current when the device is in the D1, D2, or D3 state and the PCI bus is in the B0 or B1 state.	PCI CLK at 33 MHz, device in Magic Packet or OnNow mode, receiving non-matching packets		110	mA
I_{DD_WU2}	Wake-up current when the device is in the D2 or D3 state and the PCI bus is in the B2 or B3 state.	PCI CLK LOW, PG LOW, device at Magic Packet or OnNow mode, receiving non-matching packets		80	mA
I_{DD_S}	Static I_{DD}	PCI CLK, RST, and TBC_EN pin HIGH.		100	mA

Notes:

- I_{OL2} applies to \overline{DEVSEL} , \overline{FRAME} , \overline{INTA} , \overline{IRDY} , \overline{PERR} , \overline{SERR} , \overline{STOP} , \overline{TRDY} , $EECS$, $EEDI$, $EBUA_EBA[7:0]$, $EBDA[15:8]$, $EBD[7:0]$, $EROMCS$, AS_EBOE , $EBWE$, and PHY_RST .
 I_{OL3} applies to $LED0$, $LED1$, $LED2$, $LED3$, and $LED4$.
 I_{OL4} applies to $AD[31:0]$, $C/\overline{BE}[3:0]$, PAR , and REQ pins in 5 V signalling environment.
- V_{OH} does not apply to open-drain output pins.
- I_{OH2} applies to all other outputs.
- I_{OZ} applies to all output and bidirectional pins, except the \overline{PME} pin. Tests are performed at $V_{IN} = 0$ V and at V_{DD} only.
- I_{IX} applies to all input pins except \overline{PME} , TDI , $TCLK$, and TMS pins.
- I_{IL} and I_{IH} apply to the TDI , $TCLK$, and TMS pins.
- I_{IX_PME} applies to the \overline{PME} pin only. Tests are performed at $V_{IN} = 0$ V and 5.5 V only.
- Parameter not tested. Value determined by characterization.
- C_{CLK} applies only to the CLK pin.
- C_{IDSEL} applies only to the IDSEL pin.
- Power supply current values listed here are preliminary estimates and are not guaranteed.

SWITCHING CHARACTERISTICS: BUS INTERFACE

Parameter Symbol	Parameter Name	Test Condition	Min	Max	Unit
Clock Timing					
F_{CLK}	CLK Frequency		0	33	MHz
t_{CYC}	CLK Period	@ 1.5 V for 5 V signaling @ 0.4 V_{DD} for 3.3 V signaling	30	–	ns
t_{HIGH}	CLK High Time	@ 2.0 V for 5 V signaling @ 0.4 V_{DD} for 3.3 V signaling	12		ns
t_{LOW}	CLK Low Time	@ 0.8 V for 5 V signaling @ 0.3 V_{DD} for 3.3 V signaling	12		ns
t_{FALL}	CLK Fall Time	Over 2 V p-p for 5 V signaling Over 0.4 V_{DD} for 3.3 V signaling (Note 1)	1	4	V/ns
t_{RISE}	CLK Rise Time	Over 2 V p-p for 5 V signaling Over 0.4 V_{DD} for 3.3 V signaling (Note 1)	1	4	V/ns
Output and Float Delay Timing					
t_{VAL}	AD[31:00], C/ \overline{BE} [3:0], PAR, \overline{FRAME} , \overline{IRDY} , \overline{TRDY} , STOP, \overline{DEVSEL} , \overline{PERR} , \overline{SERR} Valid Delay		2	11	ns
$t_{VAL}(\overline{REQ})$	\overline{REQ} Valid Delay		2	12	ns
t_{ON}	AD[31:00], C/ \overline{BE} [3:0], PAR, \overline{FRAME} , \overline{IRDY} , \overline{TRDY} , STOP, \overline{DEVSEL} Active Delay		2		ns
t_{OFF}	AD[31:00], C/ \overline{BE} [3:0], PAR, \overline{FRAME} , \overline{IRDY} , \overline{TRDY} , STOP, \overline{DEVSEL} Float Delay			28	ns
Setup and Hold Timing					
t_{SU}	AD[31:00], C/ \overline{BE} [3:0], PAR, \overline{FRAME} , \overline{IRDY} , \overline{TRDY} , STOP, \overline{DEVSEL} , IDSEL Setup Time		7		ns
t_H	AD[31:00], C/ \overline{BE} [3:0], PAR, \overline{FRAME} , \overline{IRDY} , \overline{TRDY} , STOP, \overline{DEVSEL} , IDSEL Hold Time		0		ns
$t_{SU}(\overline{GNT})$	\overline{GNT} Setup Time		10		ns
$t_H(\overline{GNT})$	\overline{GNT} Hold Time		0		ns

SWITCHING CHARACTERISTICS: BUS INTERFACE (Continued)

Parameter Symbol	Parameter Name	Test Condition	Min	Max	Unit
EEPROM Timing					
f _{EESK}	EESK Frequency	(Note 2)		650	kHz
t _{HIGH} (EESK)	EESK High Time		780		ns
t _{LOW} (EESK)	EESK Low Time		780		ns
t _{VAL} (EEDI)	EEDI Valid Output Delay from EESK	(Note 2)	-15	15	ns
t _{VAL} (EECS)	EECS Valid Output Delay from EESK	(Note 2)	-15	15	ns
t _{LOW} (EECS)	EECS Low Time		1550		ns
t _{SU} (EEDO)	EEDO Setup Time to EESK	(Note 2)	50		ns
t _H (EEDO)	EEDO Hold Time from EESK	(Note 2)	0		ns
JTAG (IEEE 1149.1) Test Signal Timing					
t _{J1}	TCK Frequency			10	MHz
t _{J2}	TCK Period		100		ns
t _{J3}	TCK High Time	@ 2.0 V	45		ns
t _{J4}	TCK Low Time	@ 0.8 V	45		ns
t _{J5}	TCK Rise Time			4	ns
t _{J6}	TCK Fall Time			4	ns
t _{J7}	TDI, TMS Setup Time		8		ns
t _{J8}	TDI, TMS Hold Time		10		ns
t _{J9}	TDO Valid Delay		3	30	ns
t _{J10}	TDO Float Delay			50	ns
t _{J11}	All Outputs (Non-Test) Valid Delay		3	25	ns
t _{J12}	All Outputs (Non-Test) Float Delay			36	ns
t _{J13}	All Inputs (Non-Test) Setup Time		8		ns
t _{J14}	All Inputs (Non-Test) Hold Time		7		ns

Notes:

1. Not tested; parameter guaranteed by design characterization.
2. Parameter value is given for automatic EEPROM read operation. When EEPROM port (BCR19) is used to access the EEPROM, software is responsible for meeting EEPROM timing requirements.

SWITCHING CHARACTERISTICS: BUS INTERFACE (Continued)**10BASE-T Mode**

Symbol	Parameter Description	Test Conditions	Minimum	Maximum	Unit
V_{OUT}	Output Voltage on TX± (peak)		1.55	1.98	V
V_{DIFF}	Input Differential Squelch Assert on RX± (peak)		300	520	mV
V_{DIFF}	Input Differential De-Assert Voltage on RX± (peak)		150	300	mV
I_{IX}	Input Leakage Current		-300	300	μa

Note: V_{OUT} reflects output levels prior to 1: 1.41 transformers.

Power Supply Current

Symbol	Parameter Description	Test Conditions	Maximum	Unit
I_{CC} (1 Mbps)	1 Mbps mode on TX± and RX±. Outputs driving load.	$V_{DD} = \text{Maximum}$	480	mA
I_{CC} (10 Mbps)	10BASE-T mode on TX± and RX±. Outputs driving load.	$V_{DD} = \text{Maximum}$	480	mA

SWITCHING CHARACTERISTICS: BUS INTERFACE (Continued)

External Clock

Clock Timing					
No.	Symbol	Parameter Description	Min	Max	Unit
1	t_{PER}	XCLK Period	39.996	40.004	ns
2	t_{PWH}	XCLK High Pulse Width	18	22	ns
3	t_{PWL}	XCLK Low Pulse Width	18	22	ns

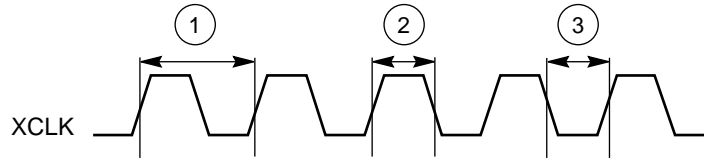

22399A-55

Figure 52. Clock Timing

PMD Interface

PECL

No.	Symbol	Parameter Description	Test Conditions	Min	Max	Unit
160	t_R (Note 1)	TX+, TX- Rise Time	PECL Load	0.5	3	ns
161	t_F (Note 1)	TX+, TX- Fall Time	PECL Load	0.5	3	ns
162	t_{SK} (Note 1)	TX+ to TX- skew	PECL Load	-	± 200	ps
163	t_S	SDI setup time to XCLK high	-	-	-	ns
164	t_H	SDI hold time to XCLK high	-	5	-	ns

Note:

1. Not included in the production test.

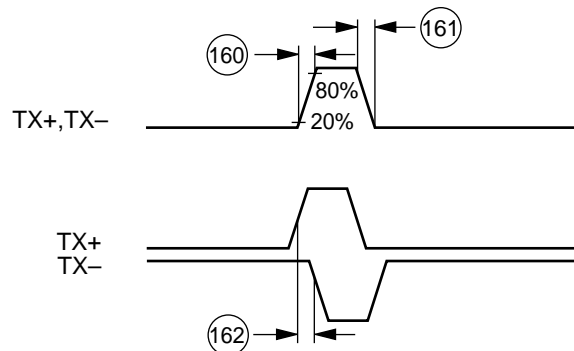

22399A-56

Figure 53. PMD Interface Timing (PECL)

SWITCHING CHARACTERISTICS: BUS INTERFACE (Continued)

10BASE-T

Symbol	Parameter Description	Test Conditions	Min	Max	Unit
t_{TETD}	Transmit End of Transmission		250	375	ns
t_{PWKRD}	RX± Pulse Width Maintain/Turn Off Threshold	$ V_{IN} > V_{THS} $ (Note 1)	136	200	ns

Note: RX_{\pm} pulses narrower than t_{PWDRD} (min) will maintain internal Carrier Sense on. RX_{\pm} pulses wider than t_{PWKRD} (max) will turn internal Carrier Sense off.

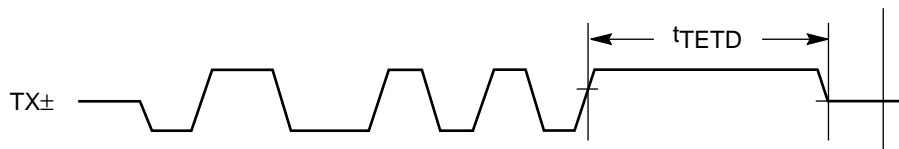

22399A-57

Figure 54. 10 Mbps Transmit (TX±) Timing Diagram

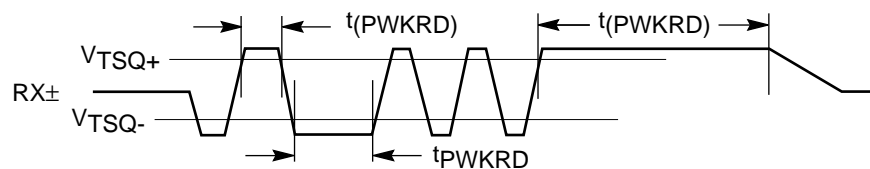

22399A-58

Figure 55. 10 Mbps Receive (RX±) Timing Diagram

SWITCHING CHARACTERISTICS: MEDIA INDEPENDENT INTERFACE



Parameter Symbol	Parameter Name	Test Condition	Min	Max	Unit
Transmit Timing					
t_{TVAL}	TX_EN and TXD valid from \uparrow TX_CLK	Measured from $V_{ilmax} = 0.8\text{ V}$ or Measured from $V_{ihmin} = 2.0\text{ V}$ (Note 1)	0	25	ns
Receive Timing					
t_{RSU}	RX_DV, RX_ER, RXD setup to \uparrow RX_CLK	Measured from $V_{ilmax} = 0.8\text{ V}$ or Measured from $V_{ihmin} = 2.0\text{ V}$ (Note 1)	10		ns
t_{RH}	RX_DV, RX_ER, RXD hold to \uparrow RX_CLK	Measured from $V_{ilmax} = 0.8\text{ V}$ or Measured from $V_{ihmin} = 2.0\text{ V}$ (Note 1)	10		ns
Management Cycle Timing					
t_{MHIGH}	MDC Pulse Width HIGH Time	$C_{LOAD} = 390\text{ pf}$	160		ns
t_{MLOW}	MDC Pulse Width LOW Time	$C_{LOAD} = 390\text{ pf}$	160		ns
t_{MCCY}	MDC Cycle Period	$C_{LOAD} = 390\text{ pf}$	400		ns
t_{MSU}	MDIO setup to \uparrow MDC	$C_{LOAD} = 470\text{ pf}$, Measured from $V_{ilmax} = 0.8\text{ V}$ or Measured from $V_{ihmin} = 2.0\text{ V}$ (Note 1)	10		ns
t_{MH}	MDIO hold to \uparrow MDC	$C_{LOAD} = 470\text{ pf}$, Measured from $V_{ilmax} = 0.8\text{ V}$ or Measured from $V_{ihmin} = 2.0\text{ V}$ (Note 1)	10		ns
t_{MVAL}	MDIO valid from \uparrow MDC	$C_{LOAD} = 470\text{ pf}$, Measured from $V_{ilmax} = 0.8\text{ V}$ or Measured from $V_{ihmin} = 2.0\text{ V}$, (Note 1)	$t_{MCCY} - t_{MSU}$		ns

Notes:

1. MDIO valid measured at the exposed mechanical Media Independent Interface.
2. TXCLK and RXCLK frequency and timing parameters are defined for the external physical layer transceiver as defined in the IEEE 802.3u standard. They are not replicated here.

SWITCHING WAVEFORMS

Key to Switching Waveforms

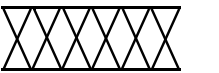
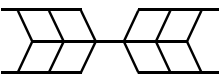
WAVEFORM	INPUTS	OUTPUTS
	Must be Steady	Will be Steady
	May Change from H to L	Will be Changing from H to L
	May Change from L to H	Will be Changing from L to H
	Don't Care, Any Change Permitted	Changing, State Unknown
	Does Not Apply	Center Line is High-Impedance "Off" State

KS000010-PAL

SWITCHING TEST CIRCUITS

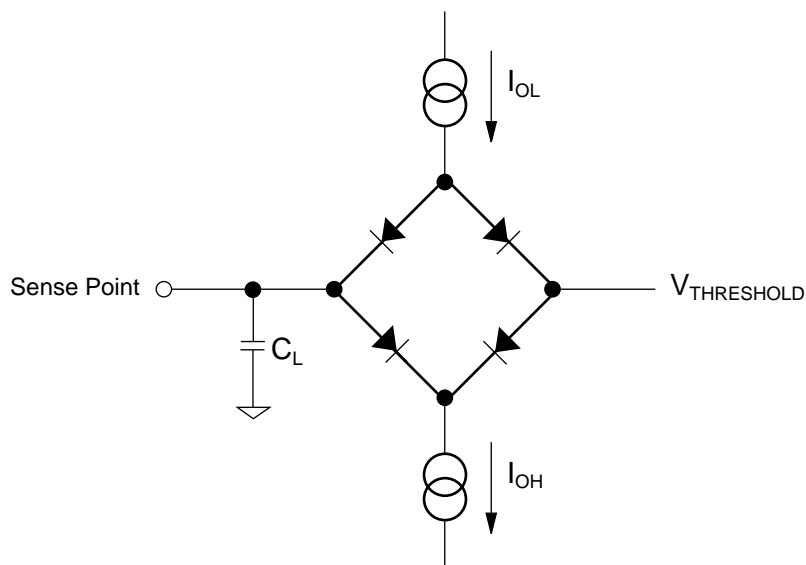

22399A-59

Figure 56. Normal and Tri-State Outputs

SWITCHING WAVEFORMS: SYSTEM BUS INTERFACE

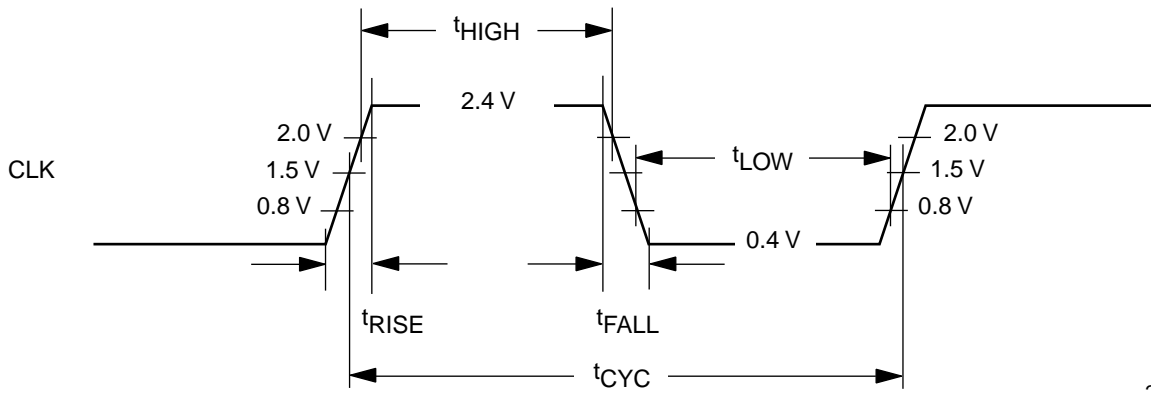

22399A-60

Figure 57. CLK Waveform for 5 V Signaling

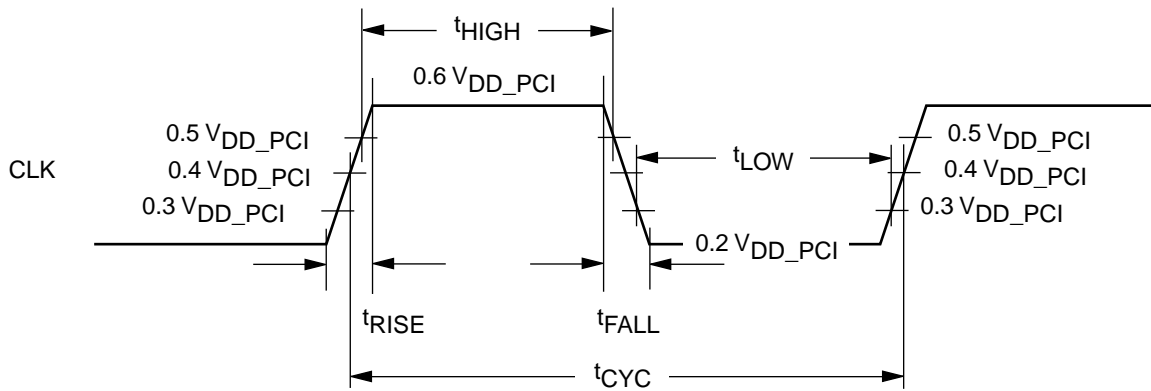

22399A-61

Figure 58. CLK Waveform for 3.3 V Signaling

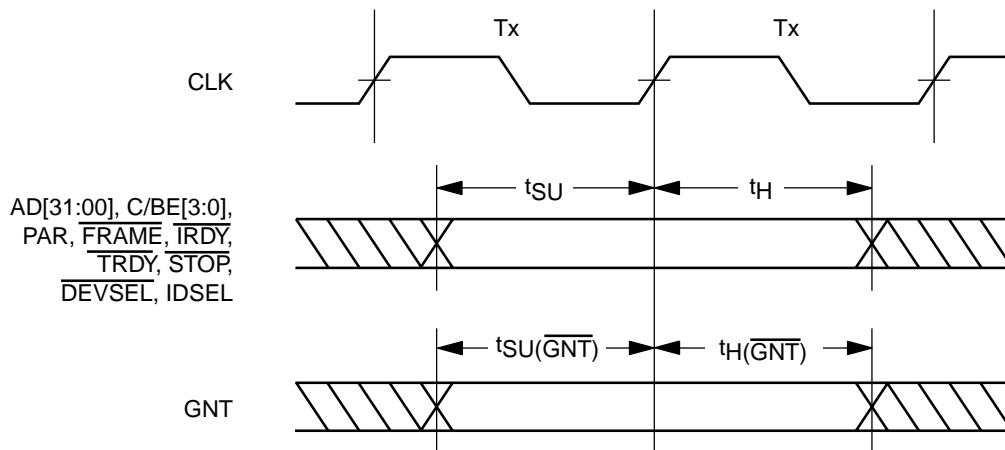

22399A-62

Figure 59. Input Setup and Hold Timing

SWITCHING WAVEFORMS: SYSTEM BUS INTERFACE (Continued)

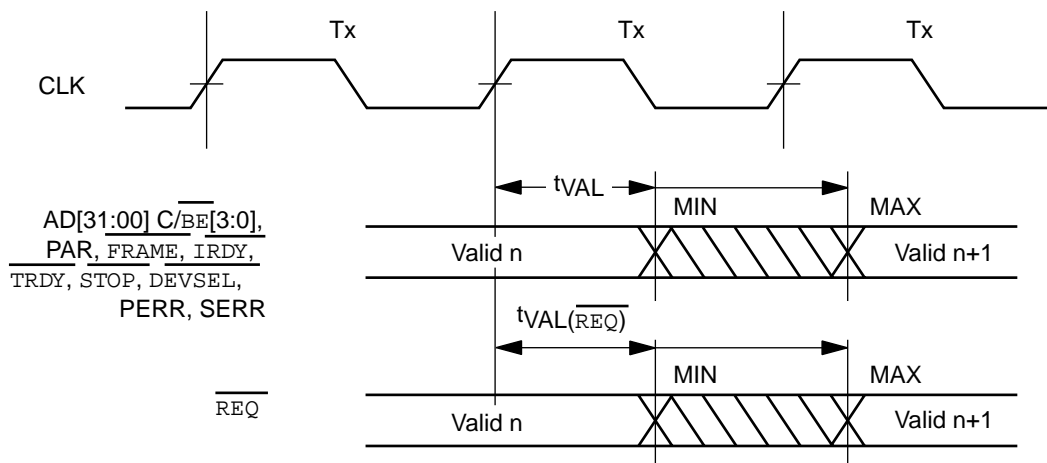

22399A-63

Figure 60. Output Valid Delay Timing

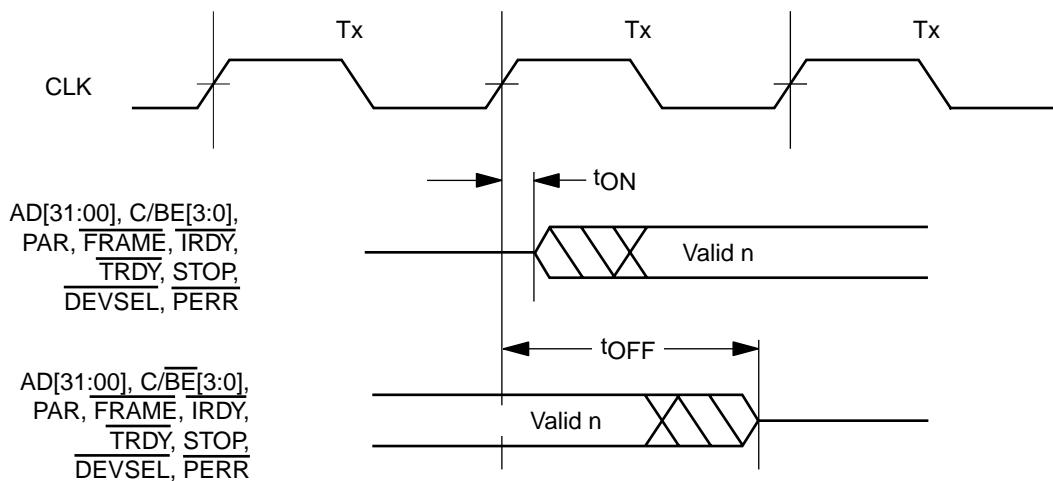

22399A-64

Figure 61. Output Tri-State Delay Timing

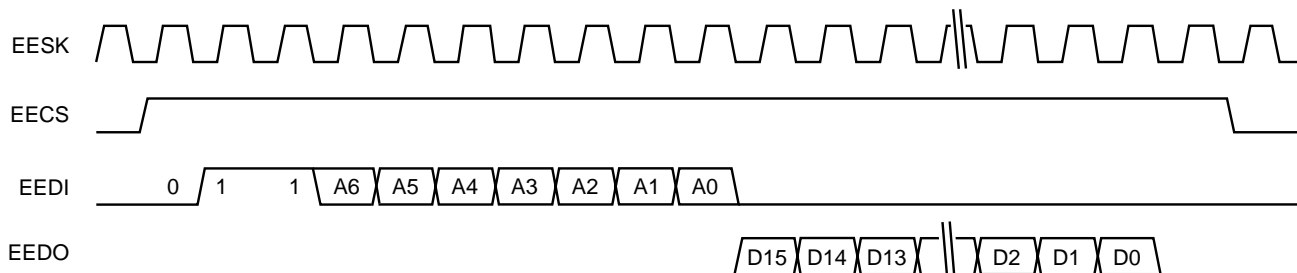

22399A-65

Figure 62. EEPROM Read Functional Timing

SWITCHING WAVEFORMS: SYSTEM BUS INTERFACE (Continued)

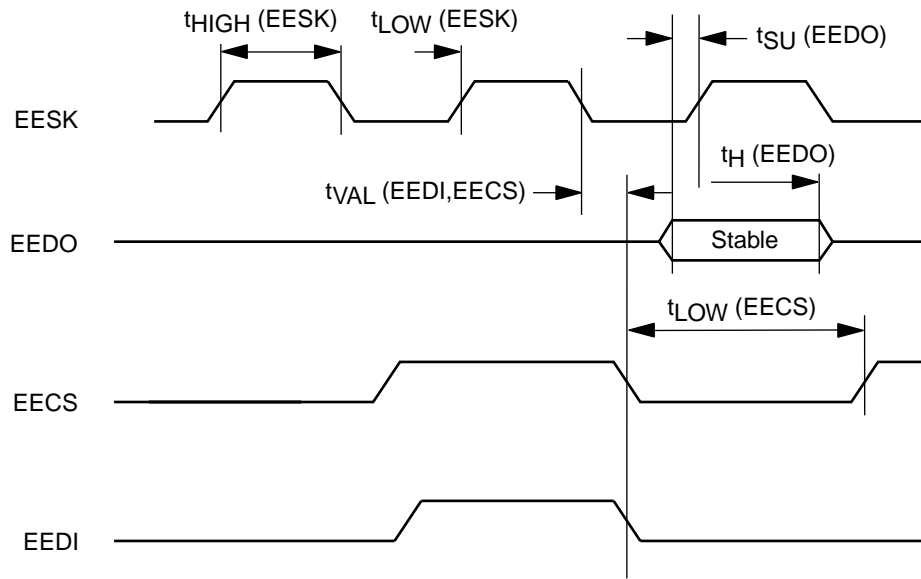

22399A-66

Figure 63. Automatic PREAD EEPROM Timing

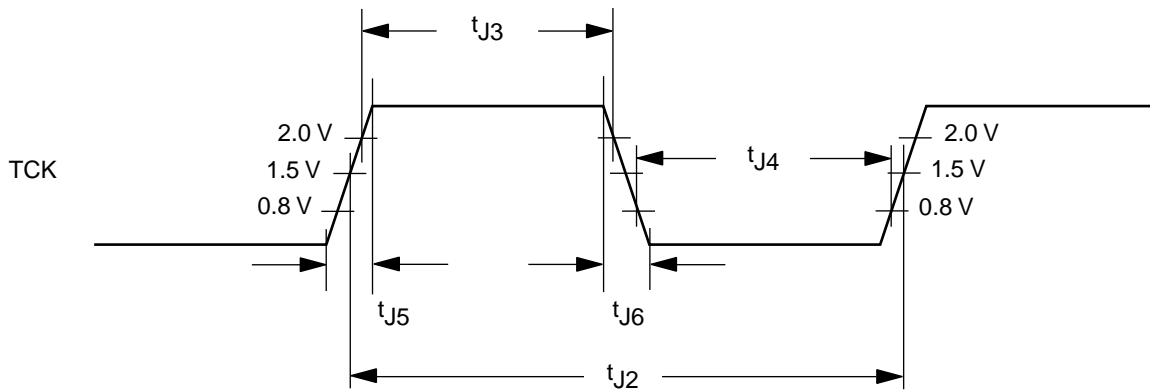

22399A-67

Figure 64. JTAG (IEEE 1149.1) TCK Waveform for 5 V Signaling

SWITCHING WAVEFORMS: SYSTEM BUS INTERFACE (Continued)

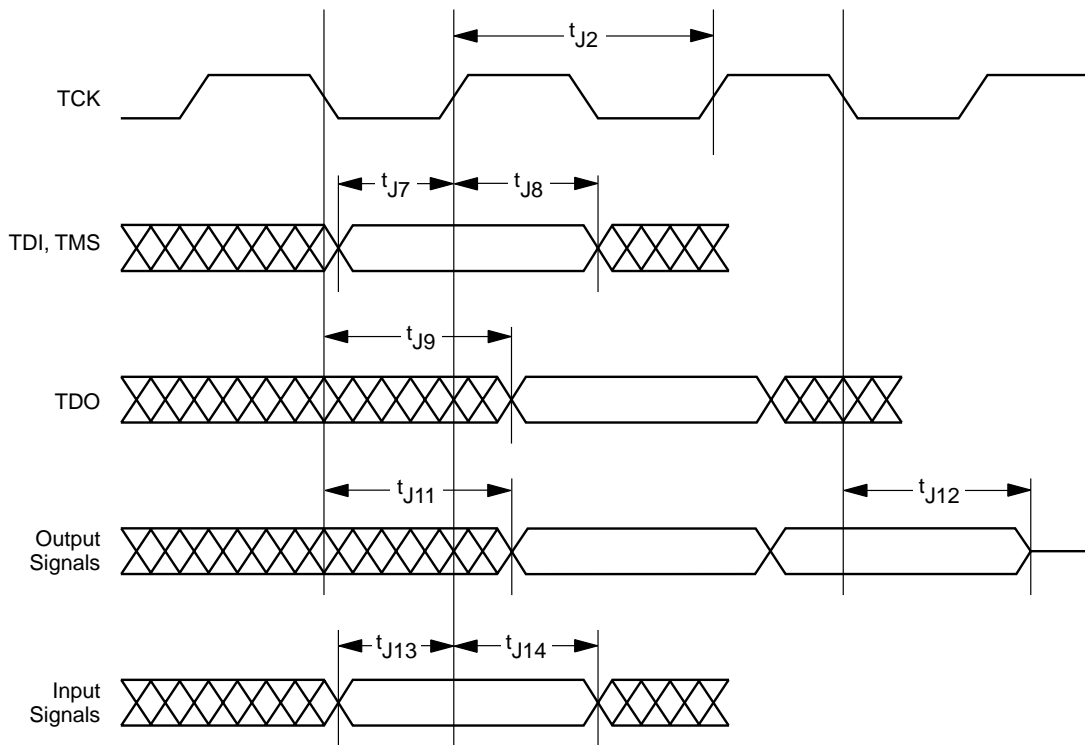

22399A-68

Figure 65. JTAG (IEEE 1149.1) Test Signal Timing

SWITCHING WAVEFORMS: MEDIA INDEPENDENT INTERFACE

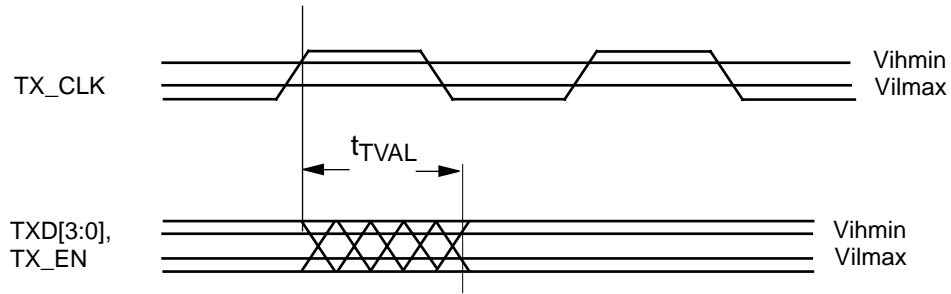

22399A-69

Figure 66. Transmit Timing

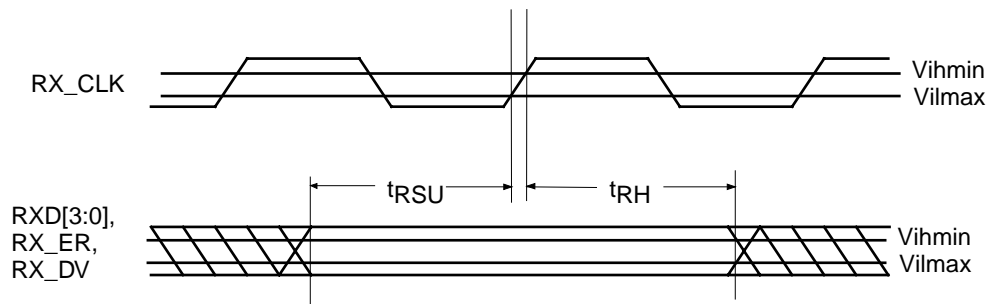

22399A-70

Figure 67. Receive Timing

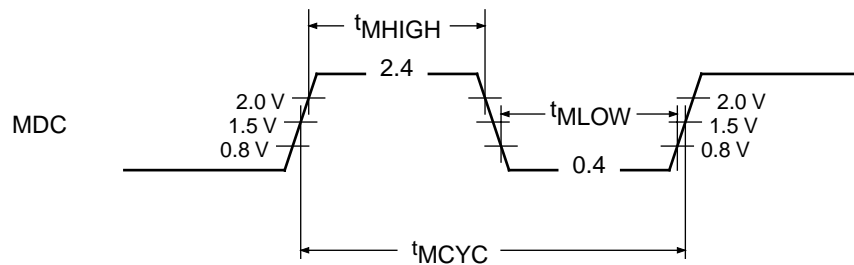

22399A-71

Figure 68. MDC Waveform

SWITCHING WAVEFORMS: MEDIA INDEPENDENT INTERFACE (Continued)

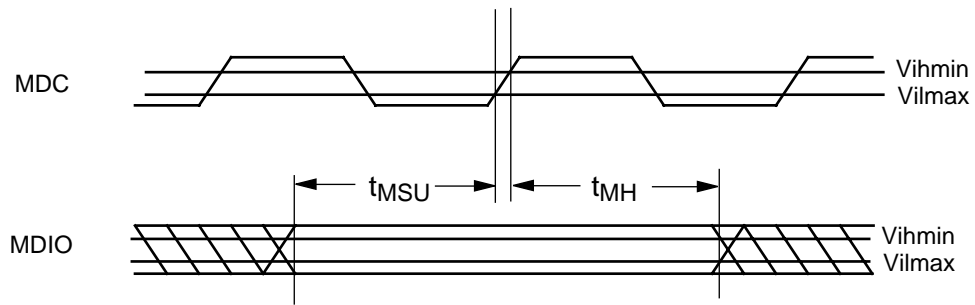

22399A-72

Figure 69. Management Data Setup and Hold Timing

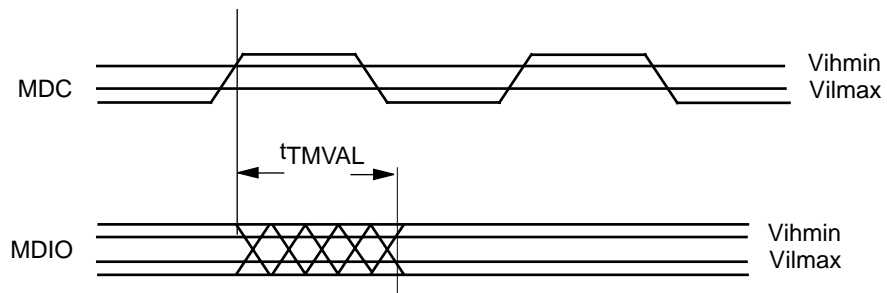

22399A-73

Figure 70. Management Data Output Valid Delay Timing

PHYSICAL DIMENSIONS*

PQL144

Thin Quad Flat Pack (measured in millimeters)

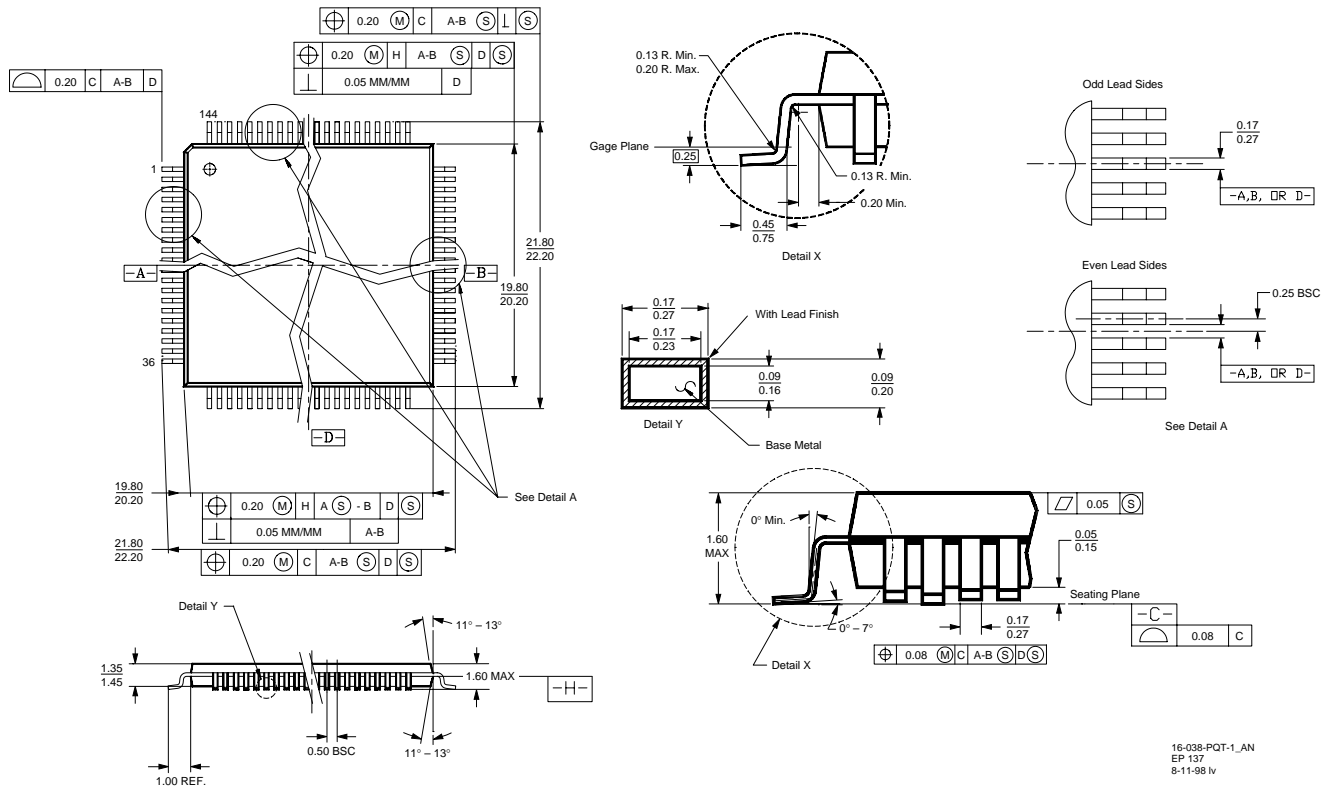

*For reference only. BSC is an ANSI standard for Basic Space Centering.

PQR160

Plastic Quad Flat Pack (measured in millimeters)

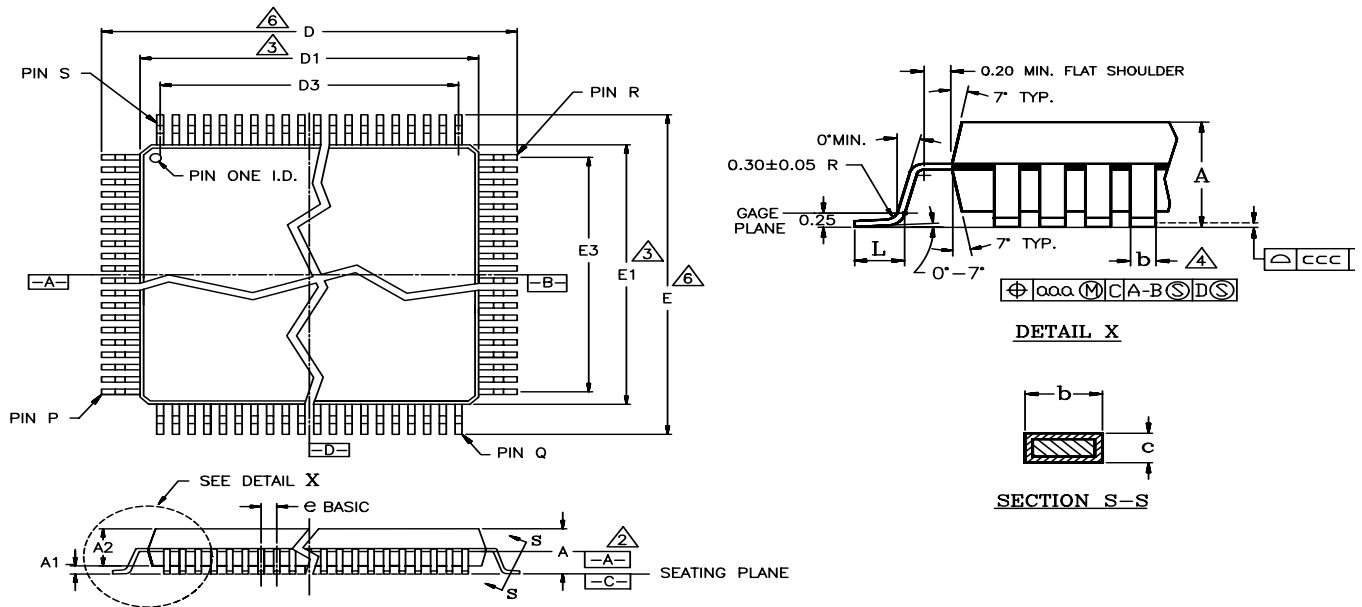

PACKAGE	PQR 160		
JEDEC	MO-108(B)DD-1		
ASYMBOL	MIN	NDM	MAX
A	—	—	3.95
A1	0.25	—	—
A2	3.20	3.40	3.60
b	0.22	—	0.38
c	0.13	—	0.23
D	31.00	31.20	31.40
D1	27.90	28.00	28.10
D3	—	25.35 REF	—
e	—	0.65 BASIC	—
E	31.00	31.20	31.40
E1	27.90	28.00	28.10
E3	—	25.35 REF	—
aaa	—	0.13	—
ccc	0.10		
L	0.73	0.88	1.03
P	40		
Q	80		
R	120		
S	160		

NOTES:

1. ALL DIMENSIONS AND TOLERANCES CONFORM TO ANSI Y14.5M-1982. DATUM PLANE [A] IS LOCATED AT THE MOLD PARTING LINE AND IS COINCIDENT WITH THE BOTTOM OF THE LEAD WHERE THE LEAD EXITS THE PLASTIC BODY.
2. DIMENSIONS "D1" AND "E1" DO NOT INCLUDE MOLD PROTRUSION. ALLOWABLE PROTRUSION IS 0.25mm PER SIDE. DIMENSIONS "D1" AND "E1" INCLUDE MOLD MISMATCH AND ARE DETERMINED AT DATUM PLANE [A].
3. DIMENSION "B" DOES NOT INCLUDE DAMBAR PROTRUSION.
4. CONTROLLING DIMENSIONS: MILLIMETER.
5. DIMENSIONS "D" AND "E" ARE MEASURED FROM BOTH INNERMOST AND OUTERMOST POINTS.
6. DEVIATION FROM LEAD-TIP TRUE POSITION SHALL BE WITHIN ±0.076 mm.
7. LEAD COPLANARITY SHALL BE WITHIN 0.10 mm.
8. COPLANARITY IS MEASURED PER SPECIFICATION 06-500.
9. HALF SPAN (CENTER OF PACKAGE TO LEAD TIP) SHALL BE WITHIN ±0.0085°

*For reference only. BSC is an ANSI standard for Basic Space Centering.

The contents of this document are provided in connection with Advanced Micro Devices, Inc. ("AMD") products. AMD makes no representations or warranties with respect to the accuracy or completeness of the contents of this publication and reserves the right to make changes to specifications and product descriptions at any time without notice. No license, whether express, implied, arising by estoppel or otherwise, to any intellectual property rights is granted by this publication. Except as set forth in AMD's Standard Terms and Conditions of Sale, AMD assumes no liability whatsoever, and disclaims any express or implied warranty, relating to its products including, but not limited to, the implied warranty of merchantability, fitness for a particular purpose, or infringement of any intellectual property right.

AMD's products are not designed, intended, authorized or warranted for use as components in systems intended for surgical implant into the body, or in other applications intended to support or sustain life, or in any other application in which the failure of AMD's product could create a situation where personal injury, death, or severe property or environmental damage may occur. AMD reserves the right to discontinue or make changes to its products at any time without notice.

© 1999 Advanced Micro Devices, Inc.
All rights reserved.

Trademarks

AMD, the AMD logo, and combinations thereof are trademarks of Advanced Micro Devices, Inc.

Auto-Poll, HomePHY, MACE, Magic Packet, PCnet, PCnet-FAST, PCnet-FAST+, PCnet-Home, PCnet-ISA, PCnet-ISA+, PCnet-ISA II, and PCnet-32 are trademarks of Advanced Micro Devices, Inc.

RLL25 is a trademark of Tut Systems, Inc.

Other product names used in this publication are for identification purposes only and may be trademarks of their respective companies.

Alternative Method for Initialization

The controller may be initialized by performing I/O writes only. That is, data can be written directly to the appropriate control and status registers (CSR instead of reading from the initialization block in memory). The registers that must be written are shown in Table A-1.

These register writes are followed by writing the START bit in CSR0.

Table A-1. Registers for Alternative Initialization Method (Note 1)

Control and Status Register	Comment
CSR2	IADR[31:16] (Note 2)
CSR8	LADRF[15:0]
CSR9	LADRF[31:16]
CSR10	LADRF[47:32]
CSR11	LADRF[63:48]
CSR12	PADR[15:0] (Note 3)
CSR13	PADR[31:16] (Note 3)
CSR14	PADR[47:32] (Note 3)
CSR15	MODE
CSR24-25	BADR
CSR30-31	BADX
CSR47	TXPOLLINT
CSR49	RXPOLLINT
CSR76	RCVRL
CSR78	XMTRL

Notes:

1. The INIT bit must not be set or the initialization block will be accessed instead.
2. Needed only if SSIZE32 =0.
3. Needed only if the physical address is different from the one stored in EEPROM or if there is no EEPROM present.

Look-Ahead Packet Processing (LAPP) Concept

INTRODUCTION

A driver for the controller would normally require that the CPU copy receive frame data from the controller's buffer space to the application's buffer space after the entire frame has been received by the controller. For applications that use a ping-pong windowing style, the traffic on the network will be halted until the current frame has been completely processed by the entire application stack. This means that the time between last byte of a receive frame arriving at the client's Ethernet controller and the client's transmission of the first byte of the next outgoing frame will be separated by:

1. The time that it takes the client's CPU interrupt procedure to pass software control from the current task to the driver,
2. Plus the time that it takes the client driver to pass the header data to the application and request an application buffer,
3. Plus the time that it takes the application to generate the buffer pointer and then return the buffer pointer to the driver,
4. Plus the time that it takes the client driver to transfer all of the frame data from the controller's buffer space into the application's buffer space and then call the application again to process the complete frame,
5. Plus the time that it takes the application to process the frame and generate the next outgoing frame, end
6. Plus the time that it takes the client driver to set up the descriptor for the controller and then write a TDMD bit to CSR0.

The sum of these times can often be about the same as the time taken to actually transmit the frames on the wire, thereby, yielding a network utilization rate of less than 50 percent.

An important thing to note is that the controller's data transfers to its buffer space are such that the system bus is needed by the controller for approximately 4 percent of the time. This leaves 96 percent of the system bus bandwidth for the CPU to perform some of the interframe operations in advance of the completion of network receive activity, if possible. The question then becomes: how much of the tasks that need to be performed between reception of a frame and transmission of the next frame can be performed

before the reception of the frame actually ends at the network, and how can the CPU be instructed to perform these tasks during the network reception time?

The answer depends upon exactly what is happening in the driver and application code, but the steps that can be performed at the same time as the receive data are arriving include as much as the first three steps and part of the fourth step shown in the sequence above. By performing these steps before the entire frame has arrived, the frame throughput can be substantially increased.

A good increase in performance can be expected when the first three steps are performed before the end of the network receive operation. A much more significant performance increase could be realized if the controller could place the frame data directly into the application's buffer space; (i.e., eliminate the need for step 4.) In order to make this work, it is necessary that the application buffer pointer be determined before the frame has completely arrived, then the buffer pointer in the next descriptor for the receive frame would need to be modified in order to direct the controller to write directly to the application buffer. More details on this operation will be given later.

An alternative modification to the existing system can gain a smaller but still significant improvement in performance. This alternative leaves Step 4 unchanged in that the CPU is still required to perform the copy operation, but it allows a large portion of the copy operation to be done before the frame has been completely received by the controller, i.e., the CPU can perform the copy operation of the receive data from the controller's buffer space into the application buffer space before the frame data has completely arrived from the network. This allows the copy operation of Step 4 to be performed concurrently with the arrival of network data, rather than sequentially, following the end of network receive activity.

OUTLINE OF LAPP FLOW

This section gives a suggested outline for a driver that utilizes the LAPP feature of the controller.

Note: The labels in the following text are used as references in the timeline diagram that follows (Figure B-1).

Setup

The driver should set up descriptors in groups of three, with the OWN and STP bits of each set of three descriptors to read as follows: 11b, 10b, 00b.

An option bit (LAPPEN) exists in CSR3, bit position 5; the software should set this bit. When set, the LAPPEN bit directs the controller to generate an INTERRUPT when STP has been written to a receive descriptor by the controller.

Flow

The controller polls the current receive descriptor at some point in time before a message arrives. The controller determines that this receive buffer is OWNed by the controller and it stores the descriptor information to be used when a message does arrive.

- N0 Frame preamble appears on the wire, followed by SFD and destination address.
- N1 The 64th byte of frame data arrives from the wire. This causes the controller to begin frame data DMA operations to the first buffer.
- C0 When the 64th byte of the message arrives, the controller performs a lookahead operation to the next receive descriptor. This descriptor should be owned by the controller.
- C1 The controller intermittently requests the bus to transfer frame data to the first buffer as it arrives on the wire.
- S1 The driver remains idle.
- C2 When the controller has completely filled the first buffer, it writes status to the first descriptor.
- C3 When the first descriptor for the frame has been written, changing ownership from the controller to the CPU, the controller will generate an SRP INTERRUPT. (This interrupt appears as a RINT interrupt in CSR0).
- S1 The SRP INTERRUPT causes the CPU to switch tasks to allow the controller's driver to run.
- C4 During the CPU interrupt-generated task switching, the controller is performing a lookahead operation to the third descriptor. At this point in time, the third descriptor is owned by the CPU.

Note: *Even though the third buffer is not owned by the controller, existing AMD Ethernet controllers will continue to perform data DMA into the buffer space that the controller already owns (i.e., buffer number 2). The controller does not know if buffer space in buffer number 2 will be sufficient or not for this frame, but it has no*

way to tell except by trying to move the entire message into that space. Only when the message does not fit will it signal a buffer error condition—there is no need to panic at this point that it discovers that it does not yet own descriptor number 3.

- S2 The first task of the drivers interrupt service routing is to collect the header information from the controller's first buffer and pass it to the application.
- S3 The application will return an application buffer pointer to the driver. The driver will add an offset to the application data buffer pointer, since the controller will be placing the first portion of the message into the first and second buffers. (The modified application data buffer pointer will only be directly used by the controller when it reaches the third buffer.) The driver will place the modified data buffer pointer into the final descriptor of the group (#3) and will grant ownership of this descriptor to the controller.
- C5 Interleaved with S2, S3, and S4 driver activity, the controller will write frame data to buffer number 2.
- S4 The driver will next proceed to copy the contents of the controller's first buffer to the beginning of the application space. This copy will be to the exact (unmodified) buffer pointer that was passed by the application.
- S5 After copying all of the data from the first buffer into the beginning of the application data buffer, the driver will begin to poll the ownership bit of the second descriptor. The driver is waiting for the controller to finish filling the second buffer.
- C6 At this point, knowing that it had not previously owned the third descriptor and knowing that the current message has not ended (there is more data in the FIFO), the controller will make a last ditch lookahead to the final (third) descriptor. This time the ownership will be TRUE (i.e., the descriptor belongs to the controller), because the driver wrote the application pointer into this descriptor and then changed the ownership to give the descriptor to the controller back at S3. Note that if steps S1, S2, and S3 have not completed at this time, a BUFF error will result.
- C7 After filling the second buffer and performing the last chance lookahead to the next descriptor, the controller will write the status and change the ownership bit of descriptor number 2.

-
- S6 After the ownership of descriptor number 2 has been changed by the controller, the next driver poll of the second descriptor will show ownership granted to the CPU. The driver now copies the data from buffer number 2 into the middle section of the application buffer space. This operation is interleaved with the C7 and C8 operations.
- C8 The controller will perform data DMA to the last buffer, whose pointer is pointing to application space. Data entering the least buffer will not need the infamous double copy that is required by existing drivers, since it is being placed directly into the application buffer space.
- N2 The message on the wire ends.
- S7 When the driver completes the copy of buffer number 2 data to the application buffer space, it begins polling descriptor number 3.
- C9 When the controller has finished all data DMA operations, it writes status and changes ownership of descriptor number 3.
- S8 The driver sees that the ownership of descriptor number 3 has changed, and it calls the application to tell the application that a frame has arrived.
- S9 The application processes the received frame and generates the next TX frame, placing it into a TX buffer.
- S10 The driver sets up the TX descriptor for the controller.

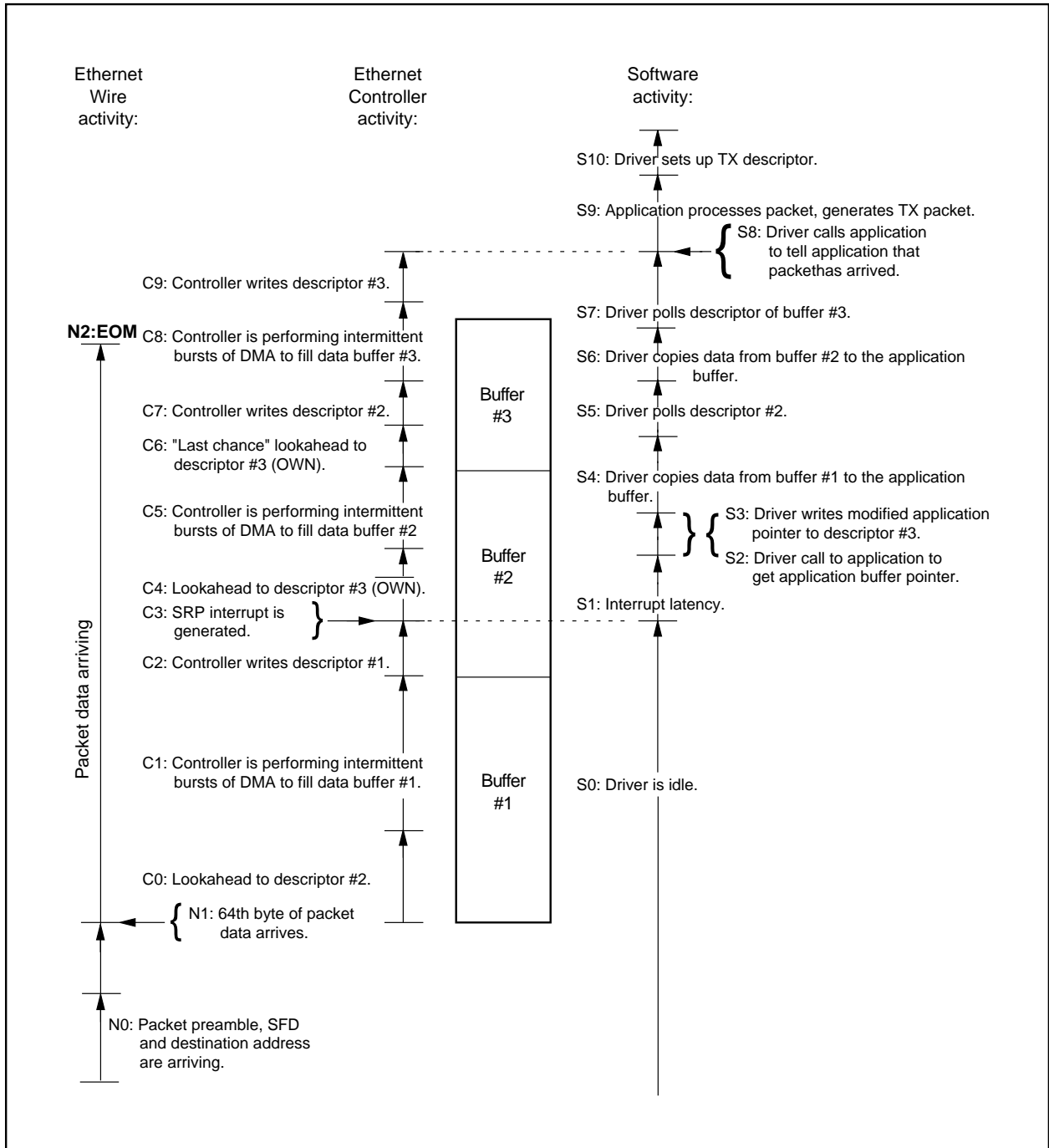

22399A-B1

Figure B-1. LAPP Timeline

LAPP Software Requirements

Software needs to set up a receive ring with descriptors formed into groups of three. The first descriptor of each group should have OWN = 1 and STP = 1, the second descriptor of each group should have OWN = 1 and STP = 0. The third descriptor of each group should have OWN = 0 and STP = 0. The size of the first buffer (as indicated in the first descriptor) should be at least equal to the largest expected header size; however, for maximum efficiency of CPU utilization, the first buffer size should be larger than the header size. It should be equal to the expected number of message bytes, minus the time needed for interrupt latency and minus the application call latency, minus the time needed for the driver to write to the third descriptor, minus the time

needed for the drive to copy data from buffer number 2 to the application buffer space. Note that the time needed for the copies performed by the driver depends upon the sizes of the second and third buffers, and that the sizes of the second and third buffers need to be set according to the time needed for the data copy operations. This means that an iterative self-adjusting mechanism needs to be placed into the software to determine the correct buffer sizing for optimal operation. Fixed values for buffer sizes may be used; in such a case, the LAPP method will still provide a significant performance increase, but the performance increase will not be maximized.

Figure B-2 illustrates this setup for a receive ring size of 9.

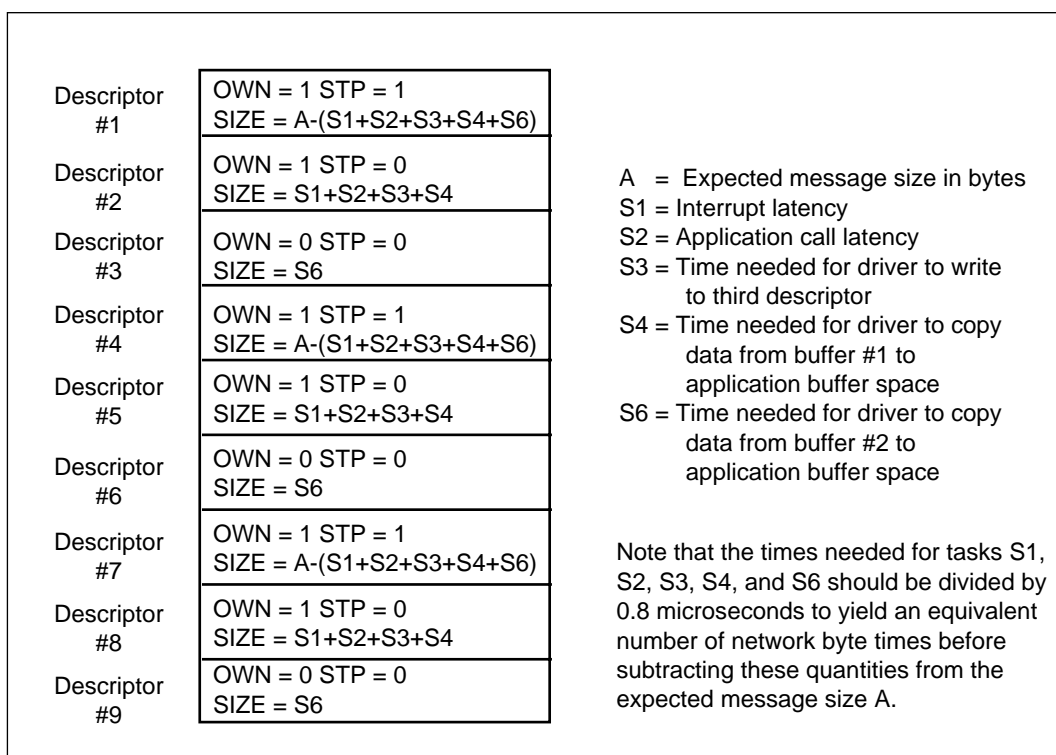

22399A-B2

Figure B-2. LAPP 3 Buffer Grouping

LAPP Rules for Parsing Descriptors

When using the LAPP method, software must use a modified form of descriptor *parsing* as follows:

- Software will examine OWN and STP to determine where an RCV frame begins. RCV frames will only begin in buffers that have OWN = 0 and STP = 1.
- Software shall assume that a frame continues until it finds either ENP = 1 or ERR = 1.
- Software must discard all descriptors with OWN = 0 and STP = 0 and move to the next descriptor when searching for the beginning of a new frame; ENP and ERR should be ignored by software during this search.
- Software cannot change an STP value in the receive descriptor ring after the initial setup of the ring is complete, even if software has ownership of the STP

descriptor, unless the previous STP descriptor in the ring is also OWNED by the software.

When LAPPEN = 1, then hardware will use a modified form of descriptor *parsing* as follows:

- The controller will examine OWN and STP to determine where to begin placing an RCV frame. A new RCV frame will only begin in a buffer that has OWN = 1 and STP = 1.
- The controller will always obey the OWN bit for determining whether or not it may use the next buffer for a chain.
- The controller will always mark the end of a frame with either ENP = 1 or ERR = 1.

The controller will discard all descriptors with OWN = 1 and STP = 0 and move to the next descriptor when searching for a place to begin a new frame. It discards these descriptors by simply changing the ownership bit from OWN = 1 to OWN = 0. Such a descriptor is un-

used for receive purposes by the controller, and the driver must recognize this. (The driver will recognize this if it follows the software rules.)

The controller will ignore all descriptors with OWN = 0 and STP = 0 and move to the next descriptor when searching for a place to begin a new frame. In other words, the controller is allowed to skip entries in the ring that it does not own, but only when it is looking for a place to begin a new frame.

Some Examples of LAPP Descriptor Interaction

Choose an expected frame size of 1060 bytes. Choose buffer sizes of 800, 200, and 200 bytes.

- **Example 1:** Assume that a 1060 byte frame arrives correctly, and that the timing of the early interrupt and the software is smooth. The descriptors will have changed from:

Descriptor Number	Before the Frame Arrives			After the Frame Arrives			Comments (After Frame Arrival)
	OWN	STP	ENP ^a	OWN	STP	ENP ^b	
1	1	1	X	0	1	0	Bytes 1-800
2	1	0	X	0	0	0	Bytes 801-1000
3	0	0	X	0	0	1	Bytes 1001-1060
4	1	1	X	1	1	X	Controller's current location
5	1	0	X	1	0	X	Not yet used
6	0	0	X	0	0	X	Not yet used
etc.	1	1	X	1	1	X	Net yet used

a. and b. ENP or ERR.

- **Example 2:** Assume that instead of the expected 1060 byte frame, a 900 byte frame arrives, either because there was an error in the

network, or because this is the last frame in a file transmission sequence.

Descriptor Number	Before the Frame Arrives			After the Frame Arrives			Comments (After Frame Arrival)
	OWN	STP	ENP ^a	OWN	STP	ENP ^b	
1	1	1	X	0	1	0	Bytes 1-800
2	1	0	X	0	0	0	Bytes 801-1000
3	0	0	X	0	0	?	Discarded buffer
4	1	1	X	1	1	X	Controller's current location
5	1	0	X	1	0	X	Not yet used
6	0	0	X	0	0	X	Not yet used
etc.	1	1	X	1	1	X	Not yet used

a. and b. ENP or ERR.

Note: The controller might write a ZERO to ENP location in the third descriptor. Here are the two possibilities:

1. If the controller finishes the data transfers into buffer number 2 after the driver writes the application modified buffer pointer into the third descriptor, then

the controller will write a ZERO to ENP for this buffer and will write a ZERO to OWN and STP.

2. If the controller finishes the data transfers into buffer number 2 before the driver writes the applications modified buffer point into the third descriptor, then

the controller will complete the frame in buffer number 2 and then skip the then unowned third buffer. In this case, the controller will not have had the opportunity to RESET the ENP bit in this descriptor, and it is possible that the software left this bit as ENP = 1 from the last time through the ring. Therefore, the software must treat the location as a *don't care*. The rule is, after finding ENP = 1 (or ERR = 1) in descriptor number 2, the software must ignore ENP bits until it finds the next STP = 1.

- **Example 3:** Assume that instead of the expected 1060 byte frame, a 100 byte frame arrives, because there was an error in the network, or because this is the last frame in a file transmission sequence, or perhaps because it is an acknowledge frame.

**Same as note in example 2 above, except that in this case, it is very unlikely that the driver can respond to the interrupt and get the pointer from the application before the controller has completed its poll of the next descriptors. This means that for almost all occurrences of this case, the controller will not find the OWN bit set for this descriptor and, therefore, the ENP bit will almost always contain the old value, since the controller will not have had an opportunity to modify it.*

***Note that even though the controller will write a ZERO to this ENP location, the software should treat the location as a don't care, since after finding the ENP = 1 in descriptor number 2, the software should ignore ENP bits until it finds the next STP = 1.*

Descriptor Number	Before the Frame Arrives			After the Frame Arrives			Comments (After Frame Arrival)
	OWN	STP	ENP ^a	OWN	STP	ENP ^b	
1	1	1	X	0	1	0	Bytes 1-800
2	1	0	X	0	0	0**	Discarded buffer
3	0	0	X	0	0	?	Discarded buffer
4	1	1	X	1	1	X	Controller's current location
5	1	0	X	1	0	X	Not yet used
6	0	0	X	0	0	X	Not yet used
etc.	1	1	X	1	1	X	Not yet used

a. and b. ENP or ERR.

Buffer Size Tuning

For maximum performance, buffer sizes should be adjusted depending upon the expected frame size and the values of the interrupt latency and application call latency. The best driver code will minimize the CPU utilization while also minimizing the latency from frame end on the network to the frame sent to application from driver (frame latency). These objectives are aimed at increasing throughput on the network while decreasing CPU utilization.

Note: *The buffer sizes in the ring may be altered at any time that the CPU has ownership of the corresponding descriptor. The best choice for buffer sizes will maximize the time that the driver is swapped out, while minimizing the time from the last byte written by the controller to the time that the data is passed from the driver to the application. In the diagram, this corresponds to maximizing S0, while minimizing the time between C9 and S8. (the timeline happens to show a minimal time from C9 to S8.)*

Note: *By increasing the size of buffer number 1, we increase the value of S0. However, when we increase the size of buffer number 1, we also increase the value of S4. If the size of buffer number 1 is too large, then the driver will not have enough time to perform tasks S2, S3, S4, S5, and S6. The result is that there will be*

delay from the execution of task C9 until the execution of task S8. A perfectly timed system will have the values for S5 and S7 at a minimum.

An average increase in performance can be achieved, if the general guidelines of buffer sizes in Figure 2 is followed. However, as was noted earlier, the correct sizing for buffers will depend upon the expected message size. There are two problems with relating expected message size with the correct buffer sizing:

1. Message sizes cannot always be accurately predicted, since a single application may expect different message sizes at different times. Therefore, the buffer sizes chosen will not always maximize throughput.
2. Within a single application, message sizes might be somewhat predictable, but when the same driver is to be shared with multiple applications, there may not be a common predictable message size.

Additional problems occur when trying to define the correct sizing because the correct size also depends upon the interrupt latency, which may vary from system to system, depending upon both the hardware and the software installed in each system.

In order to deal with the unpredictable nature of the message size, the driver can implement a self-tuning

mechanism that examines the amount of time spent in tasks S5 and S7. As such, while the driver is polling for each descriptor, it could count the number of poll operations performed and then adjust the number 1 buffer size to a larger value, by adding “t” bytes to the buffer count, if the number of poll operations was greater than “x.” If fewer than “x” poll operations were needed for each of S5 and S7, then software should adjust the buffer size to a smaller value by subtracting “y” bytes from the buffer count. Experiments with such a tuning mechanism must be performed to determine the best values for “x” and “y.”

Note: Whenever the size of buffer number 1 is adjusted, buffer sizes for buffer number 2 and buffer number 3 should also be adjusted.

In some systems, the typical mix of receive frames on a network for a client application consists mostly of large data frames, with very few small frames. In this case, for maximum efficiency of buffer sizing, when a frame arrives under a certain size limit, the driver should not adjust the buffer sizes in response to the short frame.

An Alternative LAPP Flow: Two-Interrupt Method

An alternative to the above suggested flow is to use two interrupts, one at the start of the receive frame and the other at the end of the receive frame, instead of just looking for the SRP interrupt as described above. This alternative attempts to reduce the amount of time that the software wastes while polling for descriptor own bits. This time would then be available for other CPU tasks. It also minimizes the amount of time the CPU needs for data copying. This savings can be applied to other CPU tasks.

The time from the end of frame arrival on the wire to delivery of the frame to the application is labeled as frame latency. For the one-interrupt method, frame latency is minimized, while CPU utilization increases. For the two-interrupt method, frame latency becomes greater, while CPU utilization decreases. See Figure B-3.

Note: Some of the CPU time that can be applied to non-Ethernet tasks is used for task switching in the CPU. One task switch is required to swap a non-Ethernet task into the CPU (after S7A) and a second task switch is needed to swap the Ethernet driver back in again (at S8A). If the time needed to perform these task switches exceeds the time saved by not polling descriptors, then there is a net loss in performance with this method. Therefore, the LAPP method implemented should be carefully chosen.

Figure B-4 shows the buffer sizing for the two-interrupt method. Note that the second buffer size will be about the same for each method.

There is another alternative which is a marriage of the two previous methods. This third possibility would use the buffer sizes set by the two-interrupt method, but would use the polling method of determining frame end. This will give good frame latency but at the price of very high CPU utilization. And still, there are even more compromise positions that use various fixed buffer sizes and, effectively, the flow of the one-interrupt method. All of these compromises will reduce the complexity of the one-interrupt method by removing the heuristic buffer sizing code, but they all become less efficient than heuristic code would allow.

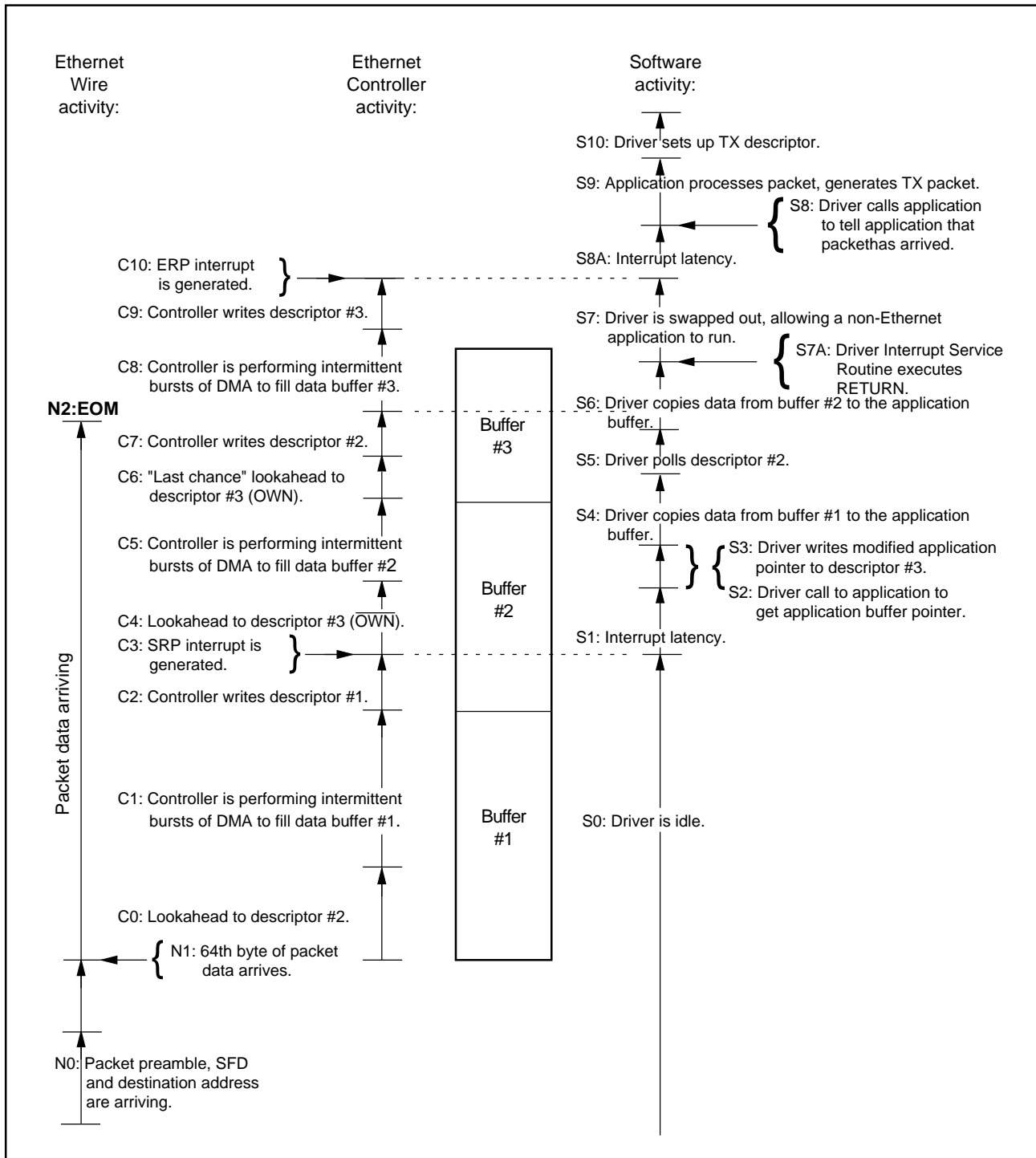

22399A-B3

Figure B-3. LAPP Timeline for Two-Interrupt Method

Descriptor #1	OWN = 1 SIZE = HEADER_SIZE (minimum 64 bytes)	STP = 1
Descriptor #2	OWN = 1 SIZE = S1+S2+S3+S4	STP = 0
Descriptor #3	OWN = 0 SIZE = 1518 - (S1+S2+S3+S4+HEADER_SIZE)	STP = 0
Descriptor #4	OWN = 1 SIZE = HEADER_SIZE (minimum 64 bytes)	STP = 1
Descriptor #5	OWN = 1 SIZE = S1+S2+S3+S4	STP = 0
Descriptor #6	OWN = 0 SIZE = 1518 - (S1+S2+S3+S4+HEADER_SIZE)	STP = 0
Descriptor #7	OWN = 1 SIZE = HEADER_SIZE (minimum 64 bytes)	STP = 1
Descriptor #8	OWN = 1 SIZE = S1+S2+S3+S4	STP = 0
Descriptor #9	OWN = 0 SIZE = 1518 - (S1+S2+S3+S4+HEADER_SIZE)	STP = 0

A = Expected message size in bytes
 S1 = Interrupt latency
 S2 = Application call latency
 S3 = Time needed for driver to write to third descriptor
 S4 = Time needed for driver to copy data from buffer #1 to application buffer space
 S6 = Time needed for driver to copy data from buffer #2 to application buffer space

Note that the times needed for tasks S1, S2, S3, S4, and S6 should be divided by 0.8 microseconds to yield an equivalent number of network byte times before subtracting these quantities from the expected message size A.

22399A-B4

Figure B-4. LAPP 3 Buffer Grouping for Two-interrupt Method

INDEX

Numerics

1 Mbps HomePNA PHY Internal Registers 187
 1 Mbps HomePNA PHY Management Registers 211
 10 Mbps Receive (RX±) Timing Diagram 223
 10 Mbps Transmit (TX±) Timing Diagram 223
 10/100 Mbps operation 2
 10/100 Media Access Control 62
 10/100 Media Access Controller 62
 10BASE-T 223
 10BASE-T Block 71
 10BASE-T I/O Buffer Power 28
 10BASE-T Mode 221
 10BASE-T PDX Analog Ground 28
 10BASE-T PDX Block Power 28
 10BASE-T PDX Digital Ground 28
 10BASE-T PHY Management Registers 210
 10BASE-T PHY Management Registers (TBRs) 177
 10BASE-T Physical Layer 71
 16-Bit Software Model 58
 32-Bit Software Model 59

A

Absolute Maximum Ratings 217
 ACCESS ID Intervals 75
 ACCESS ID Values 77
 AD 21
 Address and Data 21
 Address Match Logic 197
 Address Matching 68
 Address Parity Error Response 38
 Address PROM Space 95
 Advanced Configuration and Power Interface (ACPI) specification 1
 Advanced Parity Error Handling 49
 AID Receive Timing 77
 AID Transmit Timing 77
 Alternative Method for Initialization A-1
 Am79C978A 10BASE-T PHY Management Register Set 177
 Am79C978A Programmable Register 212
 An Alternative LAPP Flow
 Two-Interrupt Method B-8
 Analog I/O - PECL Mode 221
 Analog PLL Power 28
 APDW Values 168
 Automatic EEPROM Read Operation 83
 Automatic Pad Generation 66

Automatic Pad Stripping 69
 Automatic PREAD EEPROM Timing 228
 Auto-Negotiation 72
 Auto-Negotiation Capabilities 73
 Auto-Poll™ 1

B

Basic Burst Read Transfer 40
 Basic Burst Write Transfer 41
 Basic Non-Burst Read Transfer 39
 Basic Non-Burst Write Transfer 41
 BCR Registers 144
 BCR0
 Master Mode Read Active 143
 BCR1
 Master Mode Write Active 143
 BCR2
 Miscellaneous Configuration 145
 BCR4
 LED 0 Status 146
 BCR5
 LED1 Status 147
 BCR6
 LED2 Status 149
 BCR7
 LED3 Status 151
 BCR9
 Full-Duplex Control 153
 BCR16
 I/O Base Address Lower 154
 BCR17
 I/O Base Address Upper 154
 BCR18
 Burst and Bus Control Register 154
 BCR19
 EEPROM Control and Status 157
 BCR20
 Software Style 160
 BCR22
 PCI Latency Register 162
 BCR23
 PCI Subsystem Vendor ID Register 162
 BCR24
 PCI Subsystem ID Register 162
 BCR25
 SRAM Size Register 163

- BCR26
 - SRAM Boundary Register 163
 - BCR27
 - SRAM Interface Control Register 164
 - BCR28
 - Expansion Bus Port Address Lower (Used for Flash/EPROM and SRAM Accesses) 165
 - BCR29
 - Expansion Port Address Upper (Used for Flash/EPROM Accesses) 165
 - BCR30
 - Expansion Bus Data Port Register 166
 - BCR31
 - Software Timer Register 167
 - BCR32
 - PHY Control and Status Register 167
 - BCR33
 - PHY Address Register 169
 - BCR34
 - PHY Management Data Register 169
 - BCR35
 - PCI Vendor ID Register 170
 - BCR36
 - PCI Power Management Capabilities (PMC) Alias Register 170
 - BCR37
 - PCI DATA Register 0 (DATA0) Alias Register 170
 - BCR38
 - PCI DATA Register 1 (DATA1) Alias Register 171
 - BCR39
 - PCI DATA Register 2 (DATA2) Alias Register 171
 - BCR40
 - PCI DATA Register 3 (DATA3) Alias Register 171
 - BCR41
 - PCI DATA Register 4 (DATA4) Alias Register 172
 - BCR42
 - PCI DATA Register 5 (DATA5) Alias Register 172
 - BCR43
 - PCI DATA Register 6 (DATA6) Alias Register 172
 - BCR44
 - PCI DATA Register 7 (DATA7) Alias Register 173
 - BCR45
 - OnNow Pattern Matching Register 1 173
 - BCR46
 - OnNow Pattern Matching Register 2 174
 - BCR47
 - OnNow Pattern Matching Register 3 174
 - BCR48
 - LED4 Status 174
 - BCR49
 - PHY Select 176
 - BCR50-BCR55
 - Reserved Locations 177
 - Blanking Interval Speed Settings 78
 - BLOCK DIAGRAM 4
 - Block Diagram Low Latency Receive Configuration 82
 - Block Diagram No SRAM Configuration 82
 - Board Interface 24
 - Boundary Scan Circuit 90
 - Boundary Scan Register 90
 - BSR Mode Of Operation 90
 - Buffer Management 57
 - Buffer Management Unit 3, 56
 - Buffer Size Tuning B-7
 - Burst FIFO DMA Transfers 54
 - Burst Write Transfer 43
 - Bus Acquisition 39
 - Bus Command and Byte Enables 21
 - Bus Configuration Registers 143, 209, 214
 - Bus Configuration Registers (BCRs) 143
 - Bus Grant 21
 - Bus Master DMA Transfers 39
 - Bus Request 22
 - By Driver Type 19
- C**
- C/BE 21
 - CLK 21
 - CLK Waveform for 3.3 V Signaling 226
 - CLK Waveform for 5 V Signaling 226
 - CLK_FAC Values 165
 - Clock 21
 - Clock Interface 27
 - Clock Timing 219, 222
 - COL 25
 - Collision 25
 - Collision Detect Function 72
 - Collision Handling 65
 - CONNECTION DIAGRAM (144 TQFP) 11
 - CONNECTION DIAGRAM (160 PQFP) 12
 - Control and Status Registers 109, 203, 212
 - CRS 25
 - Crystal 28
 - Crystal Oscillator In 27
 - Crystal Oscillator Out 27
 - CSR0
 - Controller Status and Control Register 109
 - CSR1
 - Initialization Block Address 0 112
 - CSR2
 - Initialization Block Address 1 112
 - CSR3
 - Interrupt Masks and Deferral Control 113
 - CSR4
 - Test and Features Control 115
 - CSR5
 - Extended Control and Interrupt 1 116
 - CSR6
 - RX/TX Descriptor Table Length 119
 - CSR7
 - Extended Control and Interrupt 2 119
 - CSR8
 - Logical Address Filter 0 122
 - CSR9
 - Logical Address Filter 1 122
 - CSR10

Logical Address Filter 2 122	CSR39
CSR11	Next Next Transmit Descriptor Address Upper 129
Logical Address Filter 3 123	CSR40
CSR12	Current Receive Byte Count 129
Physical Address Register 0 123	CSR41
CSR13	Current Receive Status 129
Physical Address Register 1 123	CSR42
CSR14	Current Transmit Byte Count 129
Physical Address Register 2 123	CSR43
CSR15	Current Transmit Status 129
Mode 124	CSR44
CSR16	Next Receive Byte Count 129
Initialization Block Address Lower 125	CSR45
CSR17	Next Receive Status 130
Initialization Block Address Upper 125	CSR46
CSR18	Transmit Poll Time Counter 130
Current Receive Buffer Address Lower 125	CSR47
CSR19	Transmit Polling Interval 130
Current Receive Buffer Address Upper 126	CSR48
CSR20	Receive Poll Time Counter 130
Current Transmit Buffer Address Lower 126	CSR49
CSR21	Receive Polling Interval 131
Current Transmit Buffer Address Upper 126	CSR58
CSR22	Software Style 131
Next Receive Buffer Address Lower 126	CSR60
CSR23	Previous Transmit Descriptor Address Lower 133
Next Receive Buffer Address Upper 126	CSR61
CSR24	Previous Transmit Descriptor Address Upper 133
Base Address of Receive Ring Lower 126	CSR62
CSR25	Previous Transmit Byte Count 133
Base Address of Receive Ring Upper 126	CSR63
CSR26	Previous Transmit Status 133
Next Receive Descriptor Address Lower 127	CSR64
CSR27	Next Transmit Buffer Address Lower 134
Next Receive Descriptor Address Upper 127	CSR65
CSR28	Next Transmit Buffer Address Upper 134
Current Receive Descriptor Address Lower 127	CSR66
CSR29	Next Transmit Byte Count 135
Current Receive Descriptor Address Upper 127	CSR67
CSR30	Next Transmit Status 134
Base Address of Transmit Ring Lower 127	CSR72
CSR31	Receive Ring Counter 134
Base Address of Transmit Ring Upper 127	CSR74
CSR32	Transmit Ring Counter 134
Next Transmit Descriptor Address Lower 127	CSR76
CSR33	Receive Ring Length 135
Next Transmit Descriptor Address Upper 128	CSR78
CSR34	Transmit Ring Length 135
Current Transmit Descriptor Address Lower 128	CSR80
CSR35	DMA Transfer Counter and FIFO Threshold Control 135
Current Transmit Descriptor Address Upper 128	CSR82
CSR36	Transmit Descriptor Address Pointer Lower 137
Next Next Receive Descriptor Address Lower 128	CSR84
CSR37	DMA Address Register Lower 137
Next Next Receive Descriptor Address Upper 128	CSR85
CSR38	DMA Address Register Upper 138
Next Next Transmit Descriptor Address Lower 128	

CSR86
 Buffer Byte Counter 138

CSR88
 Chip ID Register Lower 138

CSR89
 Chip ID Register Upper 138

CSR92
 Ring Length Conversion 139

CSR100
 Bus Timeout 139

CSR112
 Missed Frame Count 139

CSR114
 Receive Collision Count 139

CSR116
 OnNow Power Mode Register 139, 140

CSR122
 Advanced Feature Control 141

CSR124
 Test Register 1 141

CSR125
 MAC Enhanced Configuration Control 141

Cycle Frame 21

D

Data Receive Timing 78

Data Symbol RLL25 Encoding 79

Data Symbols 78

Data Transmit Timing 78

DC Characteristics Over Commercial Operating Ranges 217

Description of the Methodology 80

Descriptor DMA Transfers 51

Descriptor Ring Read In Burst Mode 52

Descriptor Ring Read In Non-Burst Mode 52

Descriptor Ring Write In Burst Mode 53

Descriptor Ring Write In Non-Burst Mode 53

Descriptor Rings 57

Destination Address Handling 63

Detailed Functions 74

Device ID Register 90

Device Select 21

DEVSEL 21

Digital Ground (8 Pins) 27

Digital I/O (Non-PCI Pins) 217

Digital Power (6 Pins) 27

Direct Access to the Interface 83

Direct Memory Access (DMA) 2

Direct SRAM Access 81

Disconnect Of Burst Transfer 36

Disconnect Of Slave Burst Transfer - Host Inserts Wait States 37

Disconnect Of Slave Burst Transfer - No Host Wait States 37

Disconnect Of Slave Cycle When Busy 37

Disconnect When Busy 36

Disconnect With Data Transfer 42, 44

Disconnect Without Data Transfer 44, 45

DISTINCTIVE CHARACTERISTICS 1

Double Word I/O Mode 96

DVDDA 28

DVDDA_HR 28

DVDDD 28

DVDDR_X, DVDDT_X 28

DVSSD 28

DVSSX 28

E

EBCS Values 164

EECS 24

EEDET Setting 159

EEDI 25

EEDO 25

EEPROM 85

EEPROM Auto-Detection 83

EEPROM Chip Select 24

EEPROM Data In 25

EEPROM Data Out 25

EEPROM Interface 24, 82, 83

EEPROM MAP 84

EEPROM Map 85

EEPROM Read Functional Timing 227

EEPROM Serial clock 25

EEPROM Timing 220

EEPROM-Programmable Registers 83

EESK 25

Error Detection 63

Ethernet controllers in the PCnet Family 2

Ethernet Network Interfaces 26

Expansion ROM Read 36

Expansion ROM Transfers 35

External Clock 222

External Clock/Crystal Select 27

F

FIFO Burst Write At End Of Unaligned Buffer 55

FIFO Burst Write At Start Of Unaligned Buffer 55

FIFO DMA Transfers 54

Flow, LAPP B-2

FMDC Values 168

FRAME 21

Frame Format at the MII Interface Connection 31

Framing 62, 74

Full-Duplex Link Status LED Support 71

Full-Duplex Operation 71

G

GENERAL DESCRIPTION 2

GNT 21

H

H_RESET 93

Header AID Remote Control Word Commands 80

Home Networking Controller 1

Home Phoneline Networking Alliance (HomePNA) 1

- HomePNA Analog Ground 28
 - HomePNA Analog Power 28
 - HomePNA Digital Power 28
 - HomePNA PHY Framing 75
 - HomePNA PHY Network Interface 27
 - HomePNA Physical Layer (PHY) 1
 - HPR0
 - HomePNA PHY MII Control (Register 0) 187
 - HPR1
 - HomePNA PHY MII Status (Register 1) 188
 - HPR2 and HPR3
 - HomePNA PHY MII PHY ID (Registers 2 and 3) 189
 - HPR4-HPR7
 - HomePNA PHY Auto-Negotiation (Registers 4 - 7) 189
 - HPR16
 - HomePNA PHY Control (Register 16) 190
 - HPR18 and HPR19
 - HomePNA PHY TxCOMM (Registers 18 and 19) 191
 - HPR20 and HPR21
 - HomePNA PHY RxCOMM (Registers 20 and 21) 191
 - HPR22
 - HomePNA PHY AID (Register 22) 192
 - HPR23
 - HomePNA PHY Noise Control (Register 23) 192
 - HPR24
 - HomePNA PHY Noise Control 2 (Register 24) 192
 - HPR25
 - HomePNA PHY Noise Statistics (Register 25) 193
 - HPR26
 - HomePNA PHY Event Status (Register 26) 193
 - HPR27
 - HomePNA PHY Event Status (Register 27) 194
 - HPR28
 - HomePNA PHY ISBI Control (Register 28) 194
 - HPR29
 - HomePNA PHY TX Control (Register 29) 194
 - HRTXRX/HRTXRXN 27
- I**
- I/O Buffer Ground (17 Pins) 27
 - I/O Buffer Power (7 Pins) 27
 - I/O Map In DWord I/O Mode (DWIO = 1) 97
 - I/O Map in DWord I/O Mode (DWIO = 1) 97
 - I/O Map In Word I/O Mode (DWIO = 0) 96
 - I/O Registers 95
 - I/O Resources 95
 - IDSEL 21
 - IEEE 1149.1 (1990) Test Access Port Interface 26, 90
 - IEEE 1149.1 Supported Instruction Summary 90
 - IEEE 802.3 Frame And Length Field Transmission Order 70
 - IEEE 802.3u 2
 - Initialization 56
 - Initialization Block 195
 - Initialization Block (SSIZE32 = 0) 195
 - Initialization Block (SSIZE32 = 1) 195
 - Initialization Block DMA Transfers 49
 - Initialization Block Read In Burst Mode 50
 - Initialization Block Read In Non-Burst Mode 50
 - Initialization Device Select 21
 - Initiator Ready 22
 - Input Setup and Hold Timing 226
 - Instruction Register and Decoding Logic 90
 - INTA 22
 - Integrated Controllers 10
 - Integrated PCI Ethernet controller 2
 - Integrated Repeater/Hub Devices 10
 - Inter Packet Gap (IPG) 2
 - Interrupt Request 22
 - Introduction B-1
 - IRDY 22
 - IREF 26
- J**
- Jabber Function 72
 - JAM Signal 77
 - JTAG (IEEE 1149.1) TCK Waveform for 5 V Signaling 228
 - JTAG (IEEE 1149.1) Test Signal Timing 220, 229
- K**
- Key to Switching Waveforms 225
- L**
- LADRF 196
 - LAPP 3 Buffer Grouping B-5
 - LAPP 3 Buffer Grouping for Two-interrupt Method B-10
 - LAPP Software Requirements B-5
 - LAPP Timeline B-4
 - LAPP Timeline for Two-Interrupt Method B-9
 - Late Collision 67
 - LED Control Logic 86
 - LED Default Configuration 86
 - LED Support 84
 - LED0 24
 - LED1 24
 - LED2 24
 - LED3 24
 - LED4 24
 - Legal I/O Accesses in Double Word I/O Mode (DWIO = 1) 97
 - Legal I/O Accesses in Word I/O Mode (DWIO = 0) 96
 - Link Change Detect 87
 - Listed by Group 15
 - Look-Ahead Packet Processing (LAPP) 2
 - Look-Ahead Packet Processing (LAPP) Concept B-1
 - Loopback Configuration 125
 - Loopback Operation 70
 - Loss of Carrier 67
 - Low Latency Receive Configuration 81

M

MAC 62, 63, 64
Magic Packet Mode 88
Magic Packet™ mode 1
Management Cycle Timing 224
Management Data Clock 26
Management Data Input/Output 26
Management Data Output Valid Delay Timing 231
Management Data Setup and Hold Timing 231
Management Interfaces 79
Manchester Encoder/Decoder 10
Master Abort 46, 48
Master Bus Interface Unit 39
Master Cycle Data Parity Error Response 48
Master Initiated Termination 45
MDC 26
MDC Waveform 230
MDIO 26
Media Access Controller (MAC) 1, 2
Media Access Management 64
Media Independent Interface 29
Medium Allocation 64
Microsoft OnNow 2
MII Interface 25
MII interface 2
MII Management Frames 31
MII Management Interface 30
MII Network Status Interface 30
MII Receive Interface 30
MII Transmit Interface 29
Miscellaneous Loopback Features 70
Mode 196

N

NAND Tree Circuitry 91
NAND Tree Circuitry (160 PQFP) 91
NAND Tree Circuitry (160 PQFP) 91
NAND Tree Pin Sequence (144 TQFP) 92
NAND Tree Pin Sequence (160 PQFP) 92
NAND Tree Testing 91
NAND Tree Waveform 93
Network Interfaces 29
Network Port Manager 32
No SRAM Configuration 81
Non-Burst FIFO DMA Transfers 54
Non-Burst Read Transfer 40
Non-Burst Write Transfer 42
Normal and Tri-State Outputs 225

O

Offset 00h 99
Offset 02h 99
Offset 04h 100
Offset 06h 101
Offset 08h 102
Offset 09h 102
Offset 0Ah 102

Offset 0Bh 103
Offset 0Dh 103
Offset 0Eh 103
Offset 10h 103
Offset 14h 104
Offset 2Ch 104
Offset 2Eh 104
Offset 30h 105
Offset 34h 105
Offset 3Ch 105
Offset 3Dh 106
Offset 3Eh 106
Offset 3Fh 106
Offset 40h 106
Offset 41h 106
Offset 42h 106
Offset 44h 107
Offset 46h 108
Offset 47h 108
OnNow Functional Diagram 87
OnNow Pattern Match Mode 87
OnNow Wake-Up Sequence 86
Operating Ranges 217
Ordering Information 20
Other Data Registers 90
Outline of LAPP Flow B-1
Output and Float Delay Timing 219
Output Tri-State Delay Timing 227
Output Tri-state Delay Timing 227
Output Valid Delay Timing 227

P

PADR 196
PAR 22
Parity 22
Parity Error 22
Parity Error Response 37, 46
Pattern Match RAM 89
Pattern Match RAM (PMR) 87
PCI and JTAG Configuration Information 32
PCI Base-Class Register Offset 0Bh 103
PCI Bus Interface Pins - 3.3 V Signaling 217
PCI Bus Interface Pins - 5 V Signaling 217
PCI Bus Power Management Interface specification 2
PCI Capabilities Pointer Register 105
PCI Capability Identifier Register 106
PCI Command Register 100
PCI Command Register Offset 04h 100
PCI Configuration Registers 94, 98, 99, 204
PCI Configuration Space Layout 94
PCI Data Register 108
PCI Data Register Offset 47h 108
PCI Device ID Register 99
PCI Device ID Register Offset 02h 99
PCI Expansion ROM Base Address Register 105
PCI Header Type Register 103
PCI Header Type Register Offset 0Eh 103
PCI I/O Base Address Register 103

- PCI I/O Base Address Register Offset 10h 103
 PCI I/O Buffer Power (9 Pins) 27
 PCI Interface 21
 PCI Interrupt Line Register 105
 PCI Interrupt Line Register Offset 3Ch 105
 PCI Interrupt Pin Register 106
 PCI Latency Timer Register 103
 PCI MAX_LAT Register 106
 PCI Memory Mapped I/O Base Address Register 104
 PCI MIN_GNT Register 106
 PCI Next Item Pointer Register 106
 PCI Next Item Pointer Register Offset 41h 106
 PCI PMCSR Bridge Support Extensions Register 108
 PCI PMCSR Bridge Support Extensions Register Offset 46h 108
 PCI Power Management Capabilities Register (PMC) 106
 PCI Power Management Control/Status Register (PMCSR) 107
 PCI Programming Interface Register 102
 PCI Programming Interface Register Offset 09h 102
 PCI Revision ID Register 102
 PCI Status Register 101
 PCI Status Register Offset 06h 101
 PCI Sub-Class Register 102
 PCI Sub-Class Register Offset 0Ah 102
 PCI Subsystem ID Register 104
 PCI Subsystem Vendor ID Register 104
 PCI Vendor ID Register 99
 PCI Vendor ID Register Offset 00h 99
 PECL 222
 PERR 22
 PHY Control and Management Block (PCM Block) 80
 PHY Select Programming 157
 PHY/MAC Interface 71
 PHY_RST 26
 PHYSICAL DIMENSIONS 232
 Physical Layer Devices (Multi-Port) 10
 Physical Layer Devices (Single-Port) 10
 Pin Capacitance 218
 Pin Descriptions 21
 PIN DESIGNATIONS 19
 PIN DESIGNATIONS (PQL144) 15
 PIN DESIGNATIONS (PQL144) 13
 PIN DESIGNATIONS (PQR160) 14
 listed by Group 17
 PMD Interface 222
 PMD Interface Timing (PECL) 222
 PME 23
 Polling 59
 Power Good 23, 26
 Power Management Event 23
 Power Management Support 86
 Power on Reset 94
 Power Savings Mode 86
 Power Supply Current 218, 221
 Power Supply Pins 27
 PQL144 232
 PQR160 233
 Preemption During Burst Transaction 45, 47
 Preemption During Non-Burst Transaction 45, 47
R
 RAP
 Register Address Port 109
 RAP Register 108
 RDRA and TDRA 196
 Receive Address Match 69
 Receive Carrier Sense 25
 Receive Clock 25
 Receive Data 25
 Receive Data Valid 25
 Receive Descriptor (SWSTYLE = 0) 197
 Receive Descriptor (SWSTYLE = 2) 197
 Receive Descriptor (SWSTYLE = 3) 197
 Receive Descriptor Table Entry 61
 Receive Descriptors 197
 Receive Exception Conditions 69
 Receive FCS Checking 69
 Receive Frame Queuing 61
 Receive Function Programming 67
 Receive Operation 67
 Receive Symbol Timing 78
 Receive Timing 224, 230
 Receive Watermark Programming 136
 Register Administration for 10BASE-T PHY Device 80
 Register Programming Summary 212
 Register Summary 203
 Re-Initialization 56
 RELATED AMD PRODUCTS 10
 REQ 22
 Reserved Register
 10BASE-T Carrier Status Register (Register 23) 186
 10BASE-T Configuration Register (Register 22) 186
 Reserved Registers
 HPR8 - HPR15, HPR17 189
 Reserved Registers (Registers 8-15, 18, 20-23, and 25-31) 183
 Reset 23, 93
 Reset Register 95
 Reverse Polarity Detect 72
 RLEN and TLEN 195
 RLL 25 Coding Tree 79
 RMD0 197, 198
 RMD1 198
 RMD2 199
 RMD3 200
 ROMTNG Programming Values 154
 RST 23
 Running Registers 99
 RWU 24
 RX_CLK 25
 RX_DV 25
 RX_ER 25

RX± 26
RXD 25

S

S_RESET 93
Serial Receive Data 26, 27
Serial Transmit Data 26
SERR 23
Setup B-2
Setup and Hold Timing 219
Setup Registers 98
Silence Interval (AID symbol 7) 77
Slave Bus Interface Unit 32
Slave Configuration Read 34
Slave Configuration Transfers 32
Slave Configuration Write 34
Slave Cycle Data Parity Error Response 38
Slave Cycle Termination 35
Slave I/O Transfers 33
Slave Read Using I/O Command 34
Slave Write Using Memory Command 35
Soft Reset Function 73
Software Access 94
Software Interface 29
Software Interrupt Timer 62
Some Examples of LAPP Descriptor Interaction B-6
SQE Test Error 67
SRAM_BND Programming 163
Standard Products 20
STOP 23, 94
Stop 23
Supported Instructions 90
Suspend 56
Switching Characteristics
 Bus Interface 219
 Media Independent Interface 224
Switching Test Circuits 225
SWITCHING WAVEFORMS 225
Switching Waveforms
 Expansion Bus Interface 232
 General-Purpose Serial Interface 232
 Media Independent Interface 230, 232
 System Bus Interface 226
Symbol 0 (SYNC interval) 75
SYNC Receive Timing 75
SYNC Transmit Timing 75
System Bus Interface 29
System Error 23

T

TAP Finite State Machine 90
Target Abort 44, 46
Target Initiated Termination 42
Target Ready 23
TBR0
 10BASE-T PHY Control Register (Register 0) 178

TBR1
 10BASE-T Status Register (Register 1) 179
TBR2
 10BASE-T PHY Identifier (Register 2) 180
TBR3
 10BASE-T PHY Identifier (Register 3) 180
TBR4
 10BASE-T Auto-Negotiation Advertisement Register (Register 4) 181
TBR5
 10BASE-T Auto-Negotiation Link Partner Ability Register (Register 5) 182
 10BASE-T Auto-Negotiation Link Partner Ability Register (Register 5) - Base Page Format 182
 10BASE-T Auto-Negotiation Link Partner Ability Register (Register 5) - Next Page Format 182
TBR6
 10BASE-T Auto-Negotiation Expansion Register (Register 6) 183
TBR7
 10BASE-T Auto-Negotiation Next Page Register (Register 7) 183
TBR16
 10BASE-T INTERRUPT Status and Enable Register (Register 16) 184
TBR17
 10BASE-T PHY Control/Status Register (Register 17) 185
TBR19
 10BASE-T PHY Management Extension Register (Register 19) 186
TBR24
 10BASE-T Summary Status Register (Register 24) 186
TCK 26
TDI 26
TDO 26
Test Clock 26
Test Data In 26
Test Data Out 26
Test Mode Select 26
Test Registers 99
Time 75
Time Interval Unit 75
TMD0 201
TMD1 201
TMD2 202
TMD3 203
TMS 26
Transmit and Receive Message Data Encapsulation 62
Transmit Clock 26
Transmit Data 26
Transmit Data Symbol Timing 78
Transmit Descriptor (SWSTYLE = 2) 200
Transmit Descriptor (SWSTYLE = 3) 200
Transmit Descriptor Table Entry 60

Transmit Descriptors 200
Transmit Enable 26
Transmit Exception Conditions 67
Transmit FCS Generation 67
Transmit Function Programming 65
Transmit Operation 65
Transmit Start Point Programming 136
Transmit Timin 230
Transmit Timing 224, 230
Transmit Watermark Programming 137
TRDY 23
Twisted Pair Interface Status 72
Twisted Pair Receive Function 71
TX+, TX- 26
TX_CLK 26
TX_EN 26
TXD 26

U

USER ACCESSIBLE REGISTERS 98

V

VDD 27
VDD_PCI 27
VDDDB 27
VDDCO 28
VDDHR 28
VSS 27
VSSB 27
VSSHR 28

W

Word I/O Mode 95

X

XCLK/XTAL 27
XTAL1 27
XTAL2 27

