

PROGRAMMABLE HIGH-FREQUENCY CRYSTAL OSCILLATOR

SG-8002JC series

- Wide frequency range from 1MHz to 125MHz.
- Quick delivery of samples and short lead time by mass production.
- Use of C-MOS IC assures low current consumption.
- Excellent shock resistance and environmental capability.
- Output enable function (OE) and stand-by function (ST) can be used for low current consumption applications.
- Shape and pin compatible with SG-636.

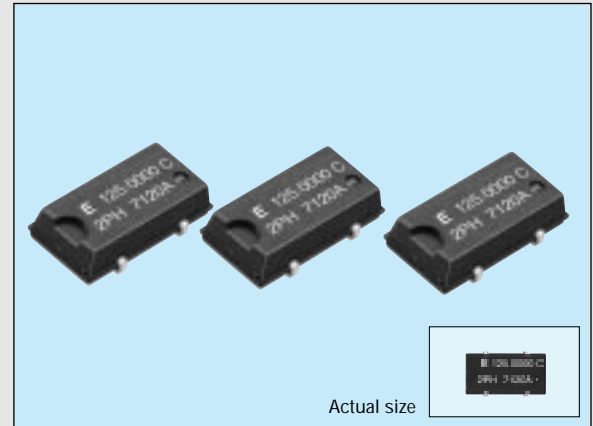

Specifications (characteristics)

Item	Symbol	PT/ST	PH/SH	PC/SC	Remarks
		Specifications			
Output frequency range	f_0	1.0000 MHz to 125.0000 MHz		1.0000 MHz to 90.0000 MHz	
Power source voltage	Max. supply voltage	V_{DD-GND}	-0.5V to +7.0V		
	Operating voltage	V_{DD}	5.0V±0.5V	2.7V to 3.6V	
Temperature range	Storage temperature	T_{STG}	-55°C to +100°C		
	Operating temperature	T_{OPR}	-20°C to +70°C		Operating voltage range
Soldering condition	T_{SOL}	Twice at under 260°C within 10 sec. or under 230°C within 3 min.			
Frequency stability	$\Delta f/f_0$	B: ±50ppm C: ± 100ppm			-20°C to +70°C
Current consumption	I_{OP}	45mA max.		25mA max.	No load condition, Max. frequency range
Output disable current	I_{OE}	30mA max.		15mA max.	OE=GND(PT, PH, PC)
Standby current	I_{ST}	50µA max.			ST=GND(ST, SH, SC)
Duty	t_w/t	—	40% to 60%		C-MOS load: 1/2 V_{DD} level
		40% to 60%	—		TTL load: 1.4V level
High output voltage	V_{OH}	$V_{DD} - 0.4V$ min.			$I_{OH} = -16mA(PT/ST, PH/SH), -8mA(PC/SC)$
Low output voltage	V_{OL}	0.4V max.			$I_{OL} = 16mA(PT/ST, PH/SH), 8mA(PC/SC)$
Output load condition (fan out)	TTL	N	5TTL max.	—	Max. frequency and max. operating voltage range
	C-MOS	C_L	15pF max.		
Output enable/disable input voltage	V_{IH}	2.0V min.		$0.7 \times V_{DD}$ min.	\overline{ST}, OE terminal
	V_{IL}	0.8V max.		$0.2 \times V_{DD}$ max.	
Output rise time	C-MOS level	t_{TLH}	4ns max.		C-MOS load: 20%→80% V_{DD}
	TTL level		4ns max.	—	TTL load: 0.4V→2.4V
Output fall time	C-MOS level	t_{THL}	4ns max.		C-MOS load: 80%→20% V_{DD}
	TTL level		4ns max.	—	TTL load: 2.4V→0.4V
Oscillation start up time	t_{OSC}	10ms max.			Time at operating voltage to be 0 sec.
Aging	f_a	±5ppm/year max.			$T_a = 25^\circ C, V_{DD} = 5.0V/3.3V(PC/SC)$
Shock resistance	S.R.	±20ppm max.			Three drops on a hard board from 75 cm or excitation test with 3000G x 0.3ms x 1/2sine wave in 3 directions

Note: • Please contact us for inquiries about usagle frequencies, duty and output load conditions.

External dimensions

(Unit: mm)

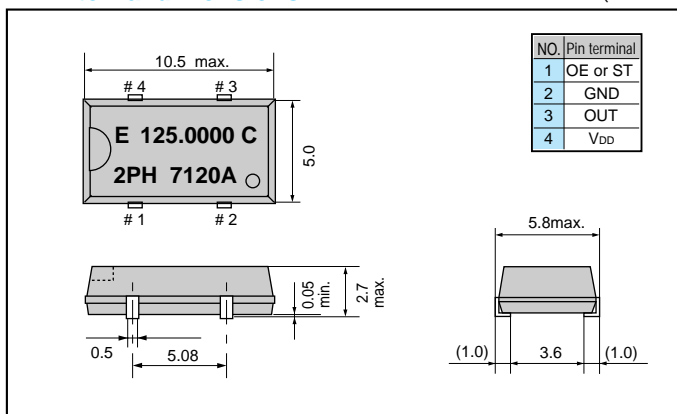

Recommended soldering pattern

(Unit: mm)

