

Features

- Few external components
- Frequency and amplitude-stable unbalanced oscillator for the VHF I-frequency range
- Frequency and amplitude-stable balanced oscillators for the VHF II- and UHF-frequency range
- Optimum decoupling of input frequency from oscillator
- Double balanced mixer with wide dynamic range and high-impedance inputs for the VHF I-frequency range
- Double balanced mixer with wide dynamic range and low-impedance inputs for the VHF II- and UHF-frequency range
- Low-impedance SAW-filter driver output
- SAW-filter driver with high signal-handling capability
- Internal band switch
- Low-noise, internal reference voltage
- Integrated 1st IF-bandpass filter

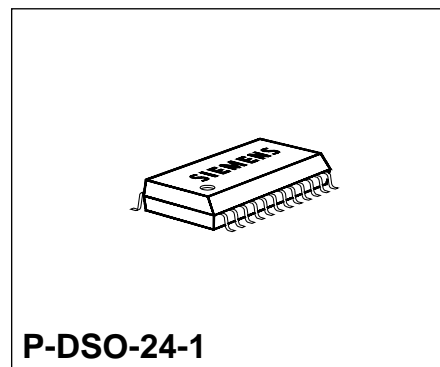

Type	Ordering Code	Package
TUA 2019-5X	Q67000-A5150	P-DSO-24-1 (SMD)
TUA 2019-5X	Q67006-A5150	P-DSO-24-1 Tape & Reel

Circuit Description

This integrated circuit permits the design of TV-tuners covering the entire frequency range from 48 ... 900 MHz split into 3 frequency bands. The application is suitable for all tuners in TV- and VCR-sets.

The integrated circuit includes 3 balanced mixers (double balanced mixer/ring mixer), one unbalanced oscillator for VHF I and two balanced oscillators for VHF II and UHF, a SAW-filter driver amplifier as well as a reference voltage source and a band switch. Filters between tuner input and IC separate the TV-frequency signal into three bands. The band switch ensures that only one band at a time is activated. In the activated band the signal passes a frontend stage with MOSFET-amplifier, a double-tuned bandpass filter and is then fed to the balanced mixer input of the IC which is a high-impedance stage for the VHF I-range and a low-impedance stage for the VHF II- and UHF-range, respectively. The input signal is mixed there with the oscillator signal from the activated oscillator section and fed into common IF-stage for all bands. The IF-signal is further amplified in a SAW-filter driver section in order to drive the SAW-filter with a low impedance.

Pin Configuration
(top view)

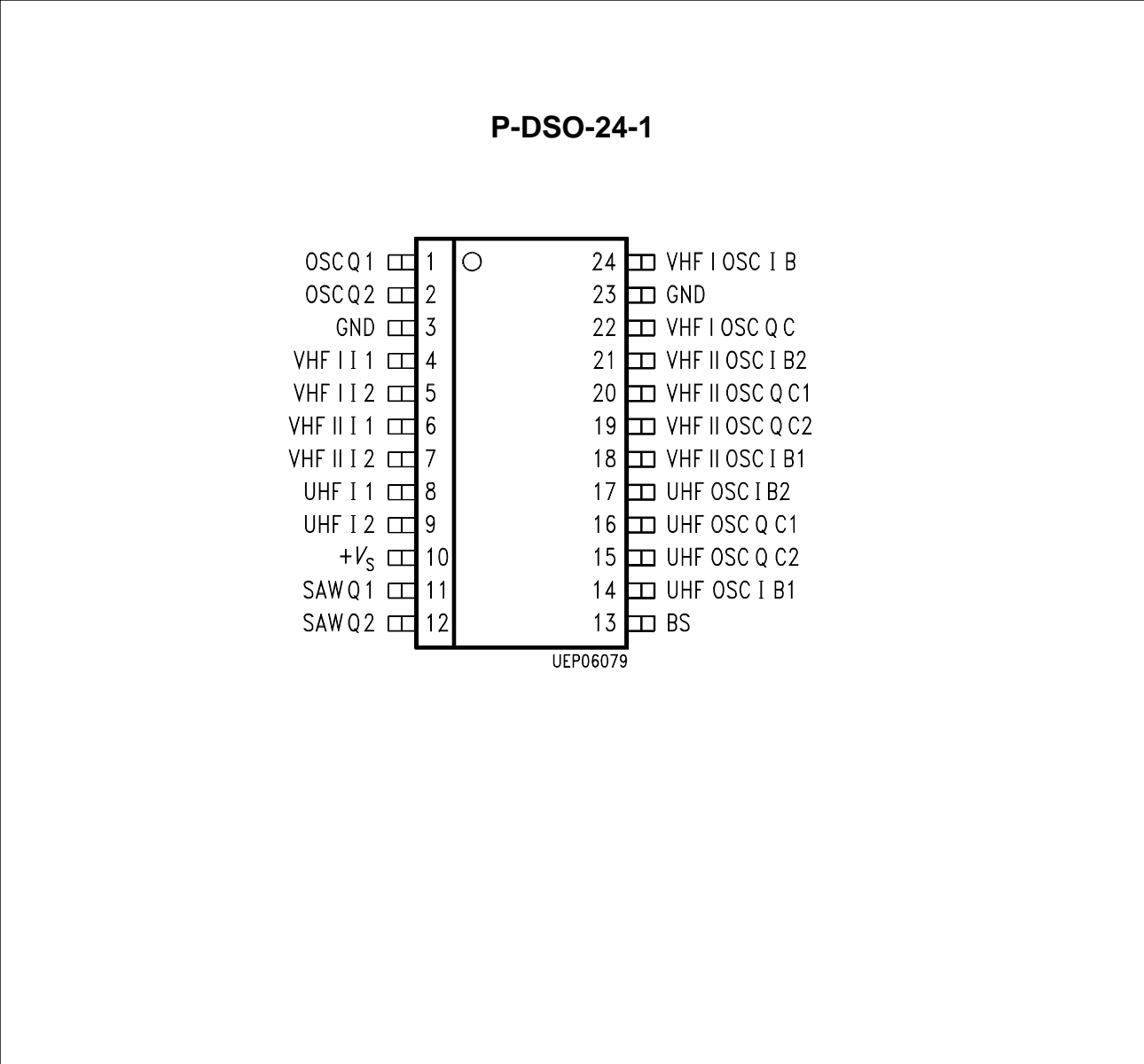

Pin Definitions and Functions

Pin No.	Symbol	Function
1	Osc. output 1	VHF I/ VHF II/ UHF-osc. signal output to PLL, symmetrical to pin 2
2	Osc. output 2	VHF I/ VHF II/ UHF-osc. signal output to PLL, symmetrical to pin 1
3	GND	Ground
4	VHF I-input 1	VHF I-mixer input high-impedance, symmetrical to pin 5
5	VHF I-input 2	VHF I-mixer input high-impedance, symmetrical to pin 4
6	VHF II-input 1	VHF II-mixer input low-impedance, symmetrical to pin 7
7	VHF II-input 2	VHF II-mixer input low-impedance, symmetrical to pin 6
8	UHF-input 1	UHF-mixer input low-impedance, symmetrical to pin 9
9	UHF-input 2	UHF-mixer input low-impedance, symmetrical to pin 8
10	+ V_S	Supply voltage
11	SAW-filter driv. out 1	SAW-filter driver output, low impedance, symmetrical to pin 12
12	SAW-filter driv. out 2	SAW-filter driver output, low impedance, symmetrical to pin 11
13	Band switch	VHF I/ VHF II/ UHF-band switch
14	UHF-osc. input B1	UHF-osc. amplifier, high-impedance base input, symmetrical to pin 17
15	UHF-osc. output C2	UHF-osc. amplifier, high-impedance coll. output, symmetrical to pin 16
16	UHF-osc. output C1	UHF-osc. amplifier, high-impedance coll. output, symmetrical to pin 15
17	UHF-osc. input B2	UHF-osc. amplifier, high-impedance base input, symmetrical to pin 14
18	VHF II-osc. input B1	VHF II-osc. amplifier, high-impedance base input, symmetrical to pin 21

Pin Definitions and Functions (cont'd)

Pin No.	Symbol	Function
19	VHF II-osc. output C2	VHF II-osc. amplifier, high-impedance collector output, symmetrical to pin 20
20	VHF II-osc. output C1	VHF II-osc. amplifier, high-impedance collector output, symmetrical to pin 19
21	VHF II-osc. input B2	VHF II-osc. amplifier, high-impedance base input, symmetrical to pin 18
22	VHF I-osc. coupling 1	VHF I-osc. coupling, collector output
23	GND	Ground
24	VHF I-osc. coupling 2	VHF I-osc. coupling, base input

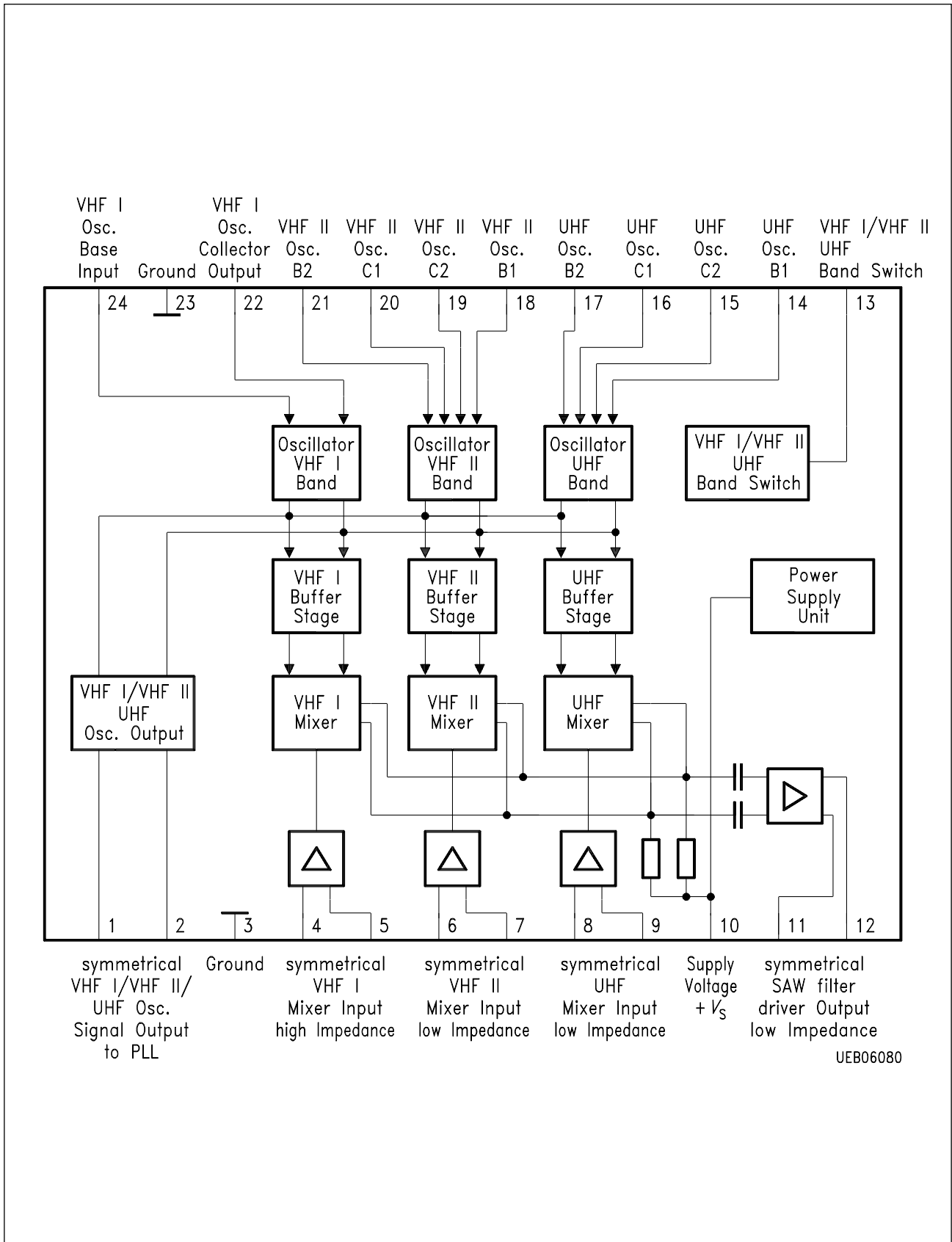

Block Diagram

Absolute Maximum Ratings $T_A = 0$ to 70 °C

Parameter	Symbol	Limit Values		Unit
		min.	max.	
Supply voltage V_S	$V_{10/3, 23}$	- 0.3	14	V
Current	I_{10}		60	mA
Switching voltage	V_{13}	- 0.3	+ V_S	V

According to application circuit 1, only the provided circuitry can be connected to pins 1, 2, 4, 5, 6, 7, 8, 9, 11, 12, 14, 15, 16, 17, 18, 19, 20, 21, 22, 24

Junction temperature	T_j		150	°C
Storage temperature	T_{stg}	- 40	125	°C
Thermal resistance	$R_{th SA}$		75	K/W

Operating Range

Supply voltage	V_S	10	13.2	V
Supply current	I_{10}	23	53	mA
VHF I-mixer input frequency range	$f_{VHF I}$	30	500	MHz
VHF II-mixer input frequency range	$f_{VHF II}$	30	900	MHz
UHF-mixer input frequency range	f_{UHF}	30	900	MHz
VHF I-oscillator frequency range	$f_{OVHF I}$	30	500	MHz
VHF II-oscillator frequency range	$f_{OVHF II}$	30	900	MHz
UHF-oscillator frequency range	f_{OUHF}	30	900	MHz
Ambient temperature	T_A	0	70	°C

Characteristics

$T_A = 25\text{ °C}; V_S = 12\text{ V}$

Parameter	Symbol	Limit Values			Unit	Test Condition	Test Circuit
		min.	typ.	max.			
Current consumption	I_{10}	30	38	45	mA	$V_{13} > 1.6\text{ V}$	1
Current consumption	I_{10}	27	34	41	mA	$V_{13} < 0.9\text{ V}$	1

VHF I-Circuit Section

Switching voltage	V_{13}	0		1	V		1
Switching current	I_{13}			10	μA	$V_{13} = 0.5\text{ V}$	1
Oscillator frequency range	$f_{\text{VHF I}}$	80		216	MHz	$V_d = 0 \dots 28\text{ V}$	1
Oscillator drift	$\Delta f_{\text{VHF I}}$			200	kHz	$V_S = 12\text{ V} \pm 10\%$ $\Delta T = 25\text{ °C}$ $t = 5\text{ s}$ up to 15 min. after switching on	1
Oscillator drift	$\Delta f_{\text{VHF I}}$			400	kHz		1
Oscillator drift	$\Delta f_{\text{VHF I}}$			200	kHz		1
Oscillator level	V_K		700		mVrms	channel E2, at hot end	1
Oscillator level	V_K		700		mVrms	channel S10, at hot end	1
Oscillator level	a_{PLL}		- 20		dBm	channel E2	1
Oscillator level	a_{PLL}		- 20		dBm	channel S10	1
Oscillator output impedance	$R_{1,2}$		100		Ω	parallel equivalent circuit	3
Oscillator output impedance	$C_{1,2}$		2		pF	parallel equivalent circuit	3
Harmonic wave ratio interference level	$a_{1,2}$			- 10	dB	$V_{\text{HF}} = 1\text{ Vrms}$	1
Oscillator pulling	$V_{4,5}$	100	108		dB/ μV	$\Delta f = 10\text{ kHz}$ in channel E2	1
Oscillator pulling	$V_{4,5}$	100	108		dB/ μV	$\Delta f = 10\text{ kHz}$ in channel S10	1
Oscillator pulling	$V_{4,5}$	80	88		dB/ μV	$\Delta f_{\text{int}} = \text{E2} + (\text{N} + 5 - 1\text{ MHz})$	1
Oscillator pulling	$V_{4,5}$	80	88		dB/ μV	$\Delta f_{\text{int}} = \text{S10} + (\text{N} + 5 - 1\text{ MHz})$	1
Gain	$G_{\text{VHF I}}$		27		dB	channel E2 pin 4, 5 > 11, 12	1
Gain	$G_{\text{VHF I}}$		27		dB	channel S10 pin 4, 5 > 11, 12	1
Mixer noise figure	$NF_{\text{VHF I}}$		7.5	9	dB	channel E2 (DSB)	2
Mixer noise figure	$NF_{\text{VHF I}}$		7.5	9	dB	channel S10 (DSB)	2

Characteristics (cont'd) $T_A = 25\text{ °C}; V_S = 12\text{ V}$

Parameter	Symbol	Limit Values			Unit	Test Condition	Test Circuit
		min.	typ.	max.			
Interference voltage	V_{int}		70		dB/ μV	1 % cross mod.; E2 ± 2	1
Interference voltage	V_{int}		70		dB/ μV	1 % cross mod.; S10 ± 2	1
Mixer input impedance	$R_{4,5}$		3		k Ω	parallel equivalent circuit	3
	$C_{4,5}$		0.5		pF	parallel equivalent circuit	3
IF-suppression	a_{IF}		20		dB	channel E2	1
IF-suppression	a_{IF}		20		dB	channel S10	1

VHF II-Circuit Section

Switching voltage	V_{13}	1.6		2.3	V		1
Switching current	I_{13}		10	30	μA	$V_{13} = 2.1\text{ V}$	1
Oscillator frequency range	$f_{\text{VHF II}}$	190		485	MHz	$V_d = 0 \dots 28\text{ V}$	1
Oscillator drift	$\Delta f_{\text{VHF II}}$			400	kHz	$V_S = 12\text{ V} \pm 10\%$	1
Oscillator drift	$\Delta f_{\text{VHF II}}$			500	kHz	$\Delta T = 25\text{ °C}$	1
Oscillator drift	$\Delta f_{\text{VHF II}}$			200	kHz	$t = 5\text{ s}$ up to 15 min. after switching on	1
Oscillator level	a_{PLL}		-20		dBm	E5 balanced tested	1
Oscillator level	a_{PLL}		-20		dBm	S37 balanced tested	1
Oscillator output impedance	$R_{1,2}$		100		Ω	parallel equivalent circuit	3
	$C_{1,2}$		2		pF	parallel equivalent circuit	3
Harmonic wave ratio interference level	$a_{1,2}$			-10	dB	$V_{\text{HF}} = 1\text{ V}_{\text{rms}}$	1
Oscillator pulling	$V_{6,7}$	100	108		dB/ μV	$\Delta f = 10\text{ kHz}$ in channel E5	1
Oscillator pulling	$V_{6,7}$	100	108		dB/ μV	$\Delta f = 10\text{ kHz}$ in channel S37	1
Oscillator pulling	$V_{6,7}$	80	88		dB/ μV	$\Delta f_{\text{int}} = K5 + (N + 5 - 1\text{ MHz})$	1
Oscillator pulling	$V_{6,7}$	80	88		dB/ μV	$\Delta f_{\text{int}} = S37 + (N + 5 - 1\text{ MHz})$	1
Gain	$G_{\text{VHF II}}$		41		dB	channel E5 pin 6, 7 > 11, 12	1
Gain	$G_{\text{VHF II}}$		41		dB	channel S37 pin 6, 7 > 11, 12	1

Characteristics (cont'd)

$T_A = 25\text{ °C}; V_S = 12\text{ V}$

Parameter	Symbol	Limit Values			Unit	Test Condition	Test Circuit
		min.	typ.	max.			
Mixer noise figure	$NF_{VHF II}$		7.5	9	dB	channel E5 (DSB)	2
Mixer noise figure	$NF_{VHF II}$		7.5	9	dB	channel S37 (DSB)	2
Interference voltage	V_{int}	97	100		dB/ μ V	1 % cross mod.; E5 \pm 2	1
Interference voltage	V_{int}	97	100		dB/ μ V	1 % cross mod.; S37 \pm 2	1
Mixer input impedance	$R_{6,7}$		25		Ω	serial equivalent circuit	3
Mixer input impedance	$L_{6,7}$		10		nH	serial equivalent circuit	3
IF-suppression	a_{IF}		20		dB	channel E5	1
IF-suppression	a_{IF}		20		dB	channel S37	1

UHF-Circuit Section

Switching voltage	V_{13}	3.2		$\leq V_S$	V		1
Switching current	I_{13}		60	300	μ A	$V_{13} = V_S$	1
Oscillator frequency range	f_{UHF}	470		900	MHz	$V_d = 0 \dots 28\text{ V}$	1
Oscillator drift	Δf_{UHF}			400	kHz	$V_S = 12\text{ V} \pm 10\%$	1
Oscillator drift	Δf_{UHF}			800	kHz	$\Delta T = 25\text{ °C}$	1
Oscillator drift	Δf_{UHF}			600	kHz	$t = 5\text{ s}$ up to 15 min. after switching on	1
Oscillator level	$V_{1,2}$		- 20		dBm	E21 balanced tested	1
Oscillator level	$V_{1,2}$		- 20		dBm	E68 balanced tested	1
Oscillator output impedance	$R_{1,2}$		100		Ω	parallel equivalent circuit	3
Oscillator output impedance	$C_{1,2}$		2		pF	parallel equivalent circuit	3
Harmonic wave ratio interference level	$a_{1,2}$			- 10	dB	$V_{HF} = 1\text{ V}_{rms}$	1
Oscillator pulling	$V_{8,9}$	100	108		dB/ μ V	$\Delta f = 10\text{ kHz}$ in channel E21	1
Oscillator pulling	$V_{8,9}$	100	108		dB/ μ V	$\Delta f = 10\text{ kHz}$ in channel E68	1
Oscillator pulling	$V_{8,9}$	80	88		dB/ μ V	$\Delta f_{int} = E21 + (N + 5 - 1\text{ MHz})$	1
Oscillator pulling	$V_{8,9}$	80	88		dB/ μ V	$\Delta f_{int} = E68 + (N + 5 - 1\text{ MHz})$	1

Characteristics (cont'd)

$T_A = 25\text{ °C}; V_S = 12\text{ V}$

Parameter	Symbol	Limit Values			Unit	Test Condition	Test Circuit
		min.	typ.	max.			
Gain	G_{UHF}		41		dB	channel E21 pin 8, 9 > 11, 12	2
Gain	G_{UHF}		41		dB	channel E68 pin 8, 9 > 11, 12	2
Mixer noise figure	NF_{UHF}		8	10	dB	channel E21 (DSB)	2
Mixer noise figure	NF_{UHF}		9	11	dB	channel E68 (DSB)	2
Interference voltage	V_{int}	97	100		dB/ μV	1 % cross mod.; E21 ± 2	1
Interference voltage	V_{int}	97	100		dB/ μV	1 % cross mod.; E68 ± 2	1
Mixer input impedance	$R_{8,9}$		25		Ω	serial equivalent circuit	3
	$L_{8,9}$		10		nH	serial equivalent circuit	3
IF-suppression	a_{IF}		20		dB	channel E21	1

SAW-Filter Driver Section

SAW-filter driver output impedance	$R_{11,12}$		75		Ω	serial equivalent circuit	4
	$C_{11,12}$		95		nH	serial equivalent circuit	4
Output voltage linearity	V_{AOFW}		24		dBm	total harmonic distortion factor $THD = 5\%$	

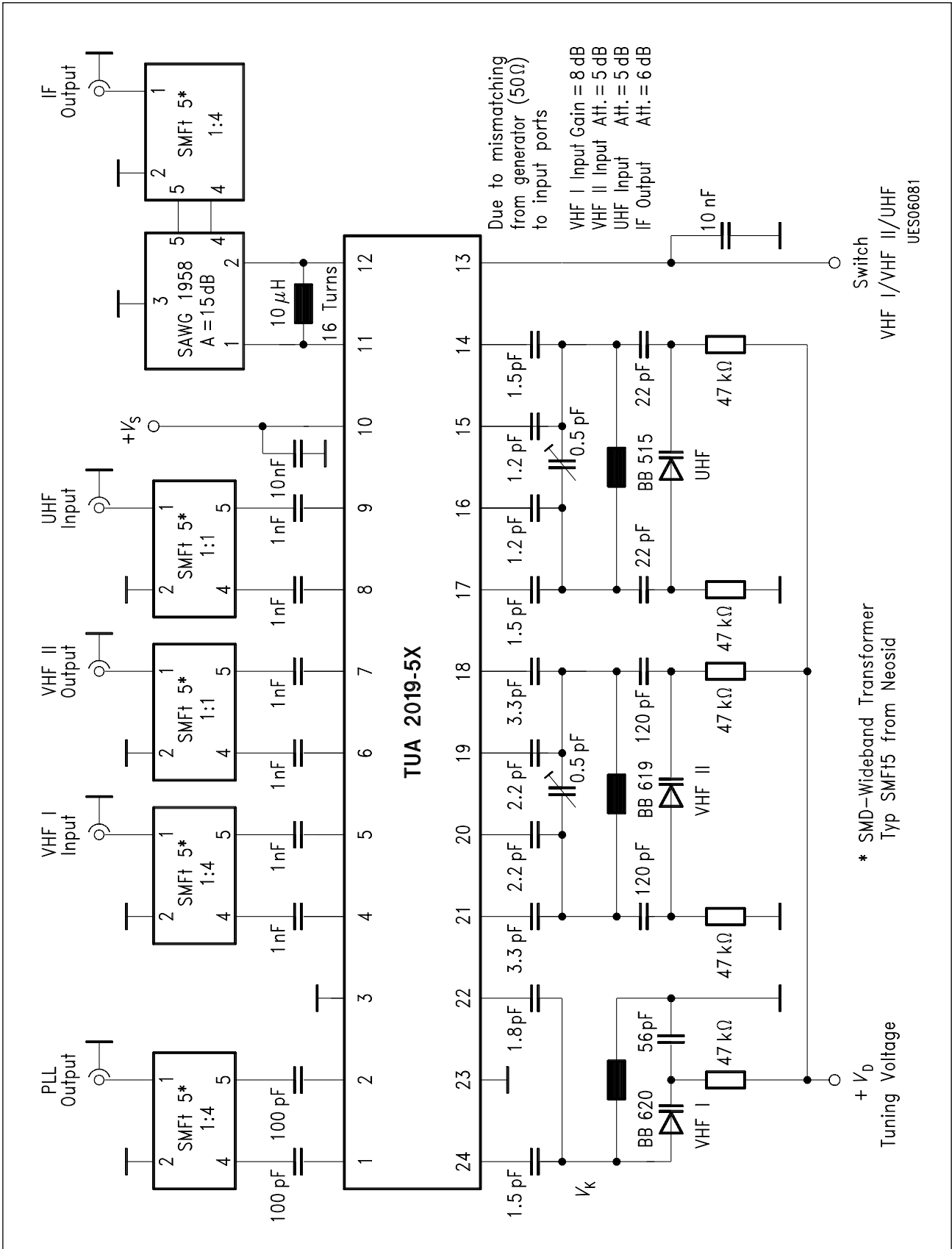

Test Circuit 1

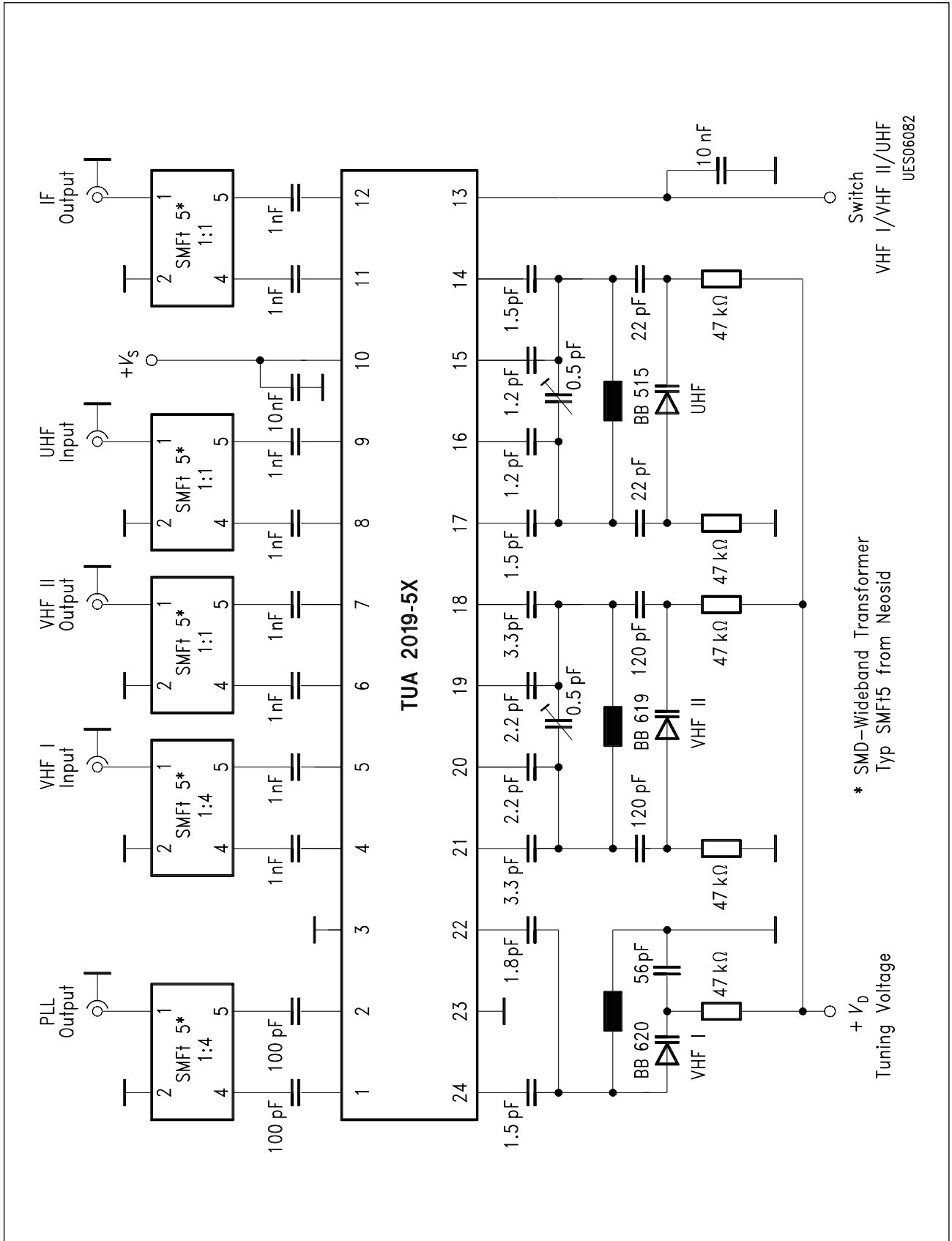

Test Circuit 2

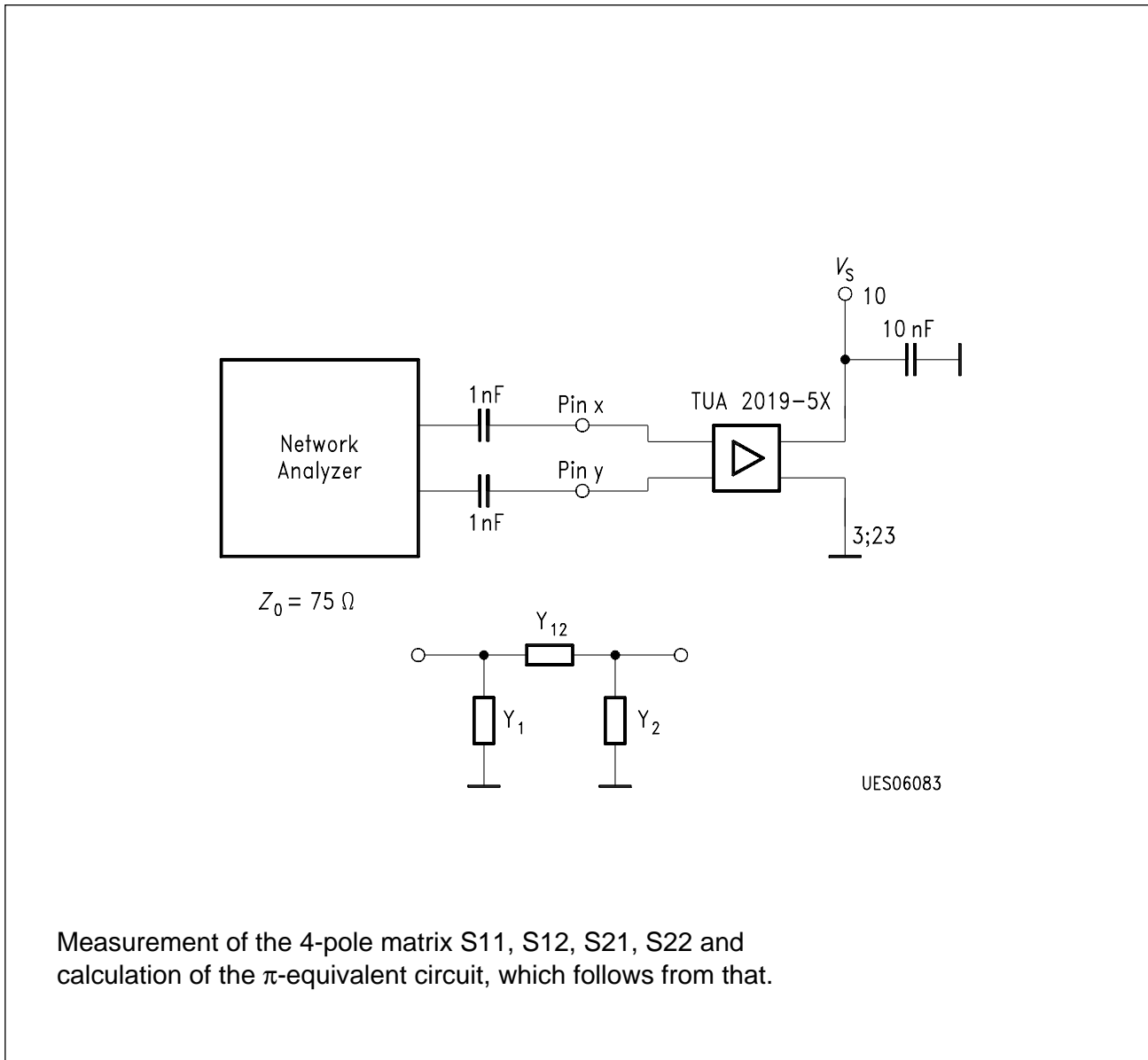

Test Circuit 3

Test Point	Test Frequency in MHz	Pin x	Pin y
Oscillator output impedance	100	1	2
Mixer input impedance VHF 1	100	4	5
Mixer input impedance VHF 2	300	6	7
Mixer input impedance UHF	600	8	9

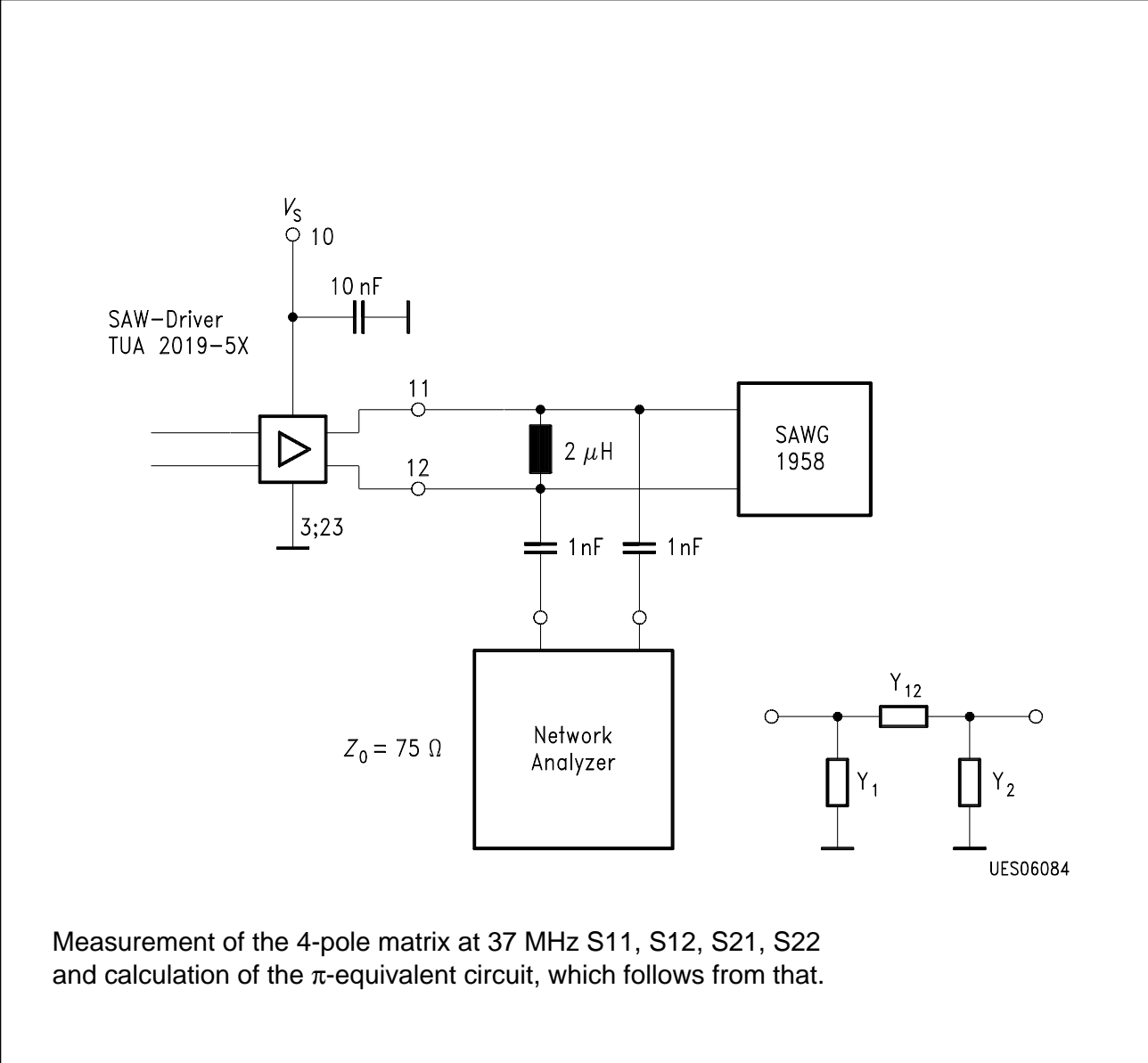

Test Circuit 4

Plastic Package, P-DSO-24-1 (SMD)
 (Plastic Dual Small Outline)

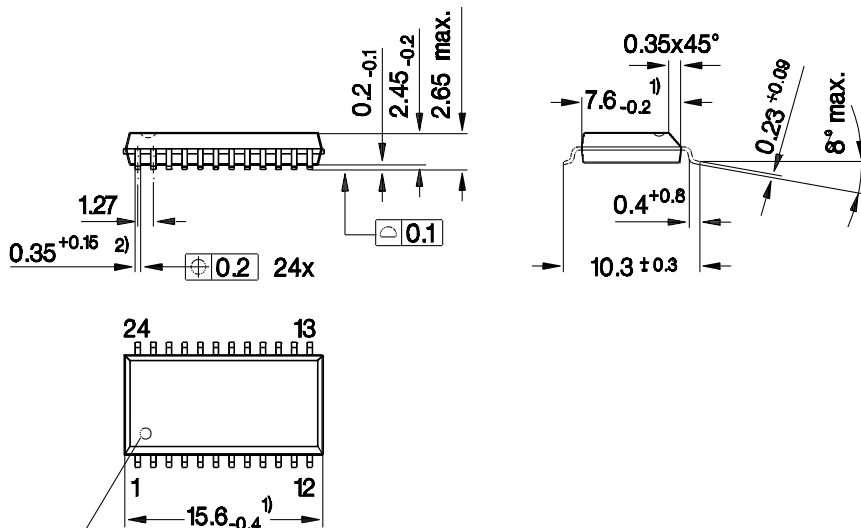

Index Marking

- 1) Does not include plastic or metal protrusion of 0.15 max. per side
- 2) Does not include dambar protrusion

GPS05144

Sorts of Packing

Package outlines for tubes, trays etc. are contained in our Data Book "Package Information"

SMD = Surface Mounted Device

Dimensions in mm