

SANYO

No. 2064C

**High-Performance
Dual Operational Amplifiers**

Overview

The LA6462 consists of two independent, internally phase compensated operational amplifiers. They feature low noise, high speed, wide band. Application areas include audio preamplifiers, active filters, and various electronic circuits.

Features

- Built-in phase compensation circuit (Gain \geq 10 dB recommended)
- Low noise: Equivalent input noise voltage
0.70 μ V typ (Rg = 2.2 k Ω RIAA, DIN Audio).
0.50 μ V typ (Rg = 300 Ω , IHF-A)
- High speed: Slew rate 4.0 V/ μ s typ.
- Wide band: Gain-bandwidth product 6 MHz typ.

Package Dimensions

unit : mm

3032-MFP8

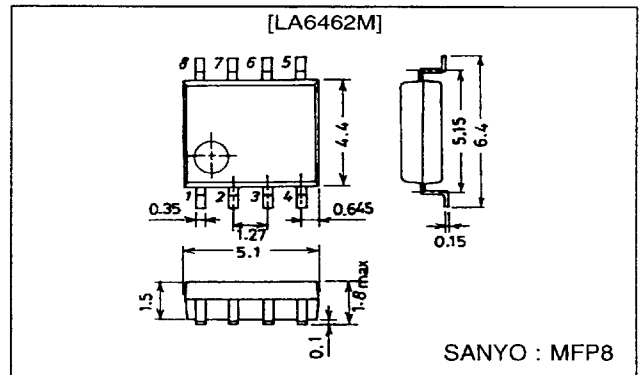

unit : mm

3017C-SIP9

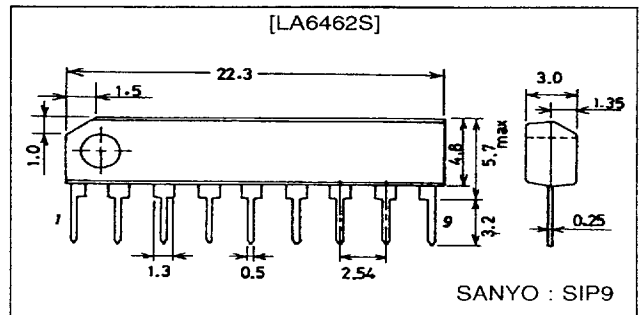

Specifications

Maximum Ratings at Ta = 25°C

Parameter	Symbol	Conditions	Ratings	Unit
Maximum supply voltage	V _{CC} /V _{EE}		\pm 18	V
Differential input voltage	V _{ID}		\pm 30	V
Common-mode input voltage	V _{IN}		\pm 15	V
Allowable power dissipation	Pd max	LA6462M	300	mW
		LA6462S	500	mW
Operating temperature	Topr		-20 to +75	°C
Storage temperature	Tstg		-40 to +125	°C

SANYO Electric Co., Ltd. Semiconductor Business Headquarters
TOKYO OFFICE Tokyo Bldg., 1-10, 1 Chome, Ueno, Taito-ku, TOKYO, 110 JAPAN

7997076 0016155 390

53096HA(II)/4050YT/8077KI/3277KI, TS No. 2064-1/5

LA6462M, 6462S

Operating Characteristics at $T_a = 25^\circ\text{C}$, $V_{CC} = 15\text{ V}$, $V_{EE} = -15\text{ V}$

Parameter	Symbol	Conditions	min	typ	max	Unit
Input offset voltage	V_{IO}	$R_S = 10\text{ k}\Omega$		0.3	6.0	mV
Input offset current	I_{IO}			5	200	nA
Input bias current	I_B			200	500	nA
Common-mode input voltage	V_{ICM}		± 12	± 14		V
Common-mode rejection ratio	CMRR		70	90		dB
Voltage gain	V_{GO}	$R_L \geq 2\text{ k}\Omega$, $V_O = \pm 10\text{ V}$	96	110		dB
Maximum output voltage	V_O (1)	$R_L \geq 10\text{ k}\Omega$		± 14		V
	V_O (2)	$R_L \geq 2\text{ k}\Omega$		± 13		V
Slew rate	SR	$V_G = 0$, $R_L \geq 2\text{ k}\Omega$		4.0		V/ μs
Equivalent input noise voltage	V_{NI} (1)	$R_g = 2.2\text{ k}\Omega$, RIAA, DIN audio weight		0.70		μV
	V_{NI} (2)	$R_g = 300\ \Omega$, IHF-A weight		0.50		μV
Current drain	I_{CC}			6.0		mA
Power dissipation	P_d			180		mW
Gain-bandwidth product	f_T			6		MHz

Test Circuits

(1) V_{IO} , SVRR

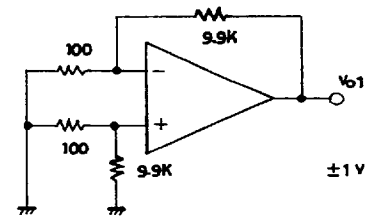

$\cdot V_{IO}: V_{CC}/V_{EE} = \pm 15\text{V}$

$\cdot \text{SVRR}: \begin{cases} V_{CC} = 15\text{V}, 5\text{V} \\ V_{EE} = -5\text{V}, -15\text{V} \end{cases}$

(2) V_O

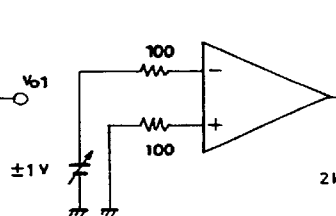

$\cdot V_{IO} = V_{O1} / 100$

$\cdot \left. \begin{matrix} \text{SVR}(+) \\ \text{SVR}(-) \end{matrix} \right\} = \left| \frac{\Delta V_{O1}}{100 \times 10\text{V}} \right|$

(3) CMRR, V_{ICM}

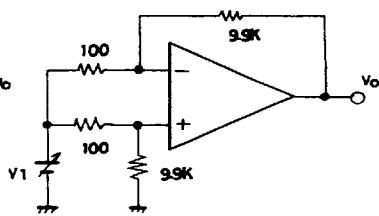

$\cdot \text{CMRR } V_1 = \pm 7.5\text{V}$

$\text{CMR} = 20 \log \frac{15 \times 100}{|\Delta V_{O'}|}$

(4) I_B (+)

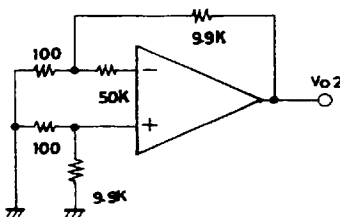

$\cdot I_B (+) = \frac{|V_{O2} - V_{O1}|}{50\text{k}\Omega \times 100}$

(5) I_B (-)

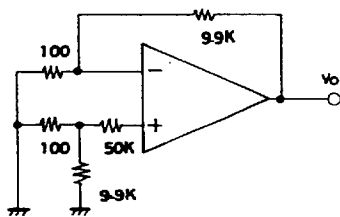

$\cdot I_B (-) = \frac{|V_{O3} - V_{O1}|}{50\text{k}\Omega \times 100}$

(6) I_{IO}

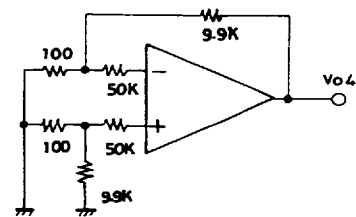

$\cdot I_{IO} = \frac{|V_{O4} - V_{O1}|}{50\text{k}\Omega \times 100}$

(7) I_{CC}

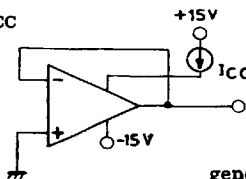

(8) SR

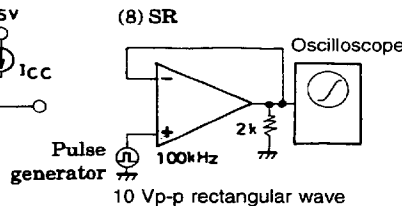

(9) V_{GO}

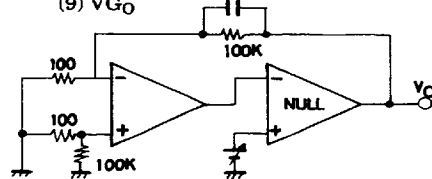

$\cdot V_{GO} = 20 \log \frac{1000 \times 20}{\Delta V_O}$

LA6462M, 6462S

(10) V_{IN1}

RIAA (36dB/1kHz)
Total Gain 80dB/1kHz

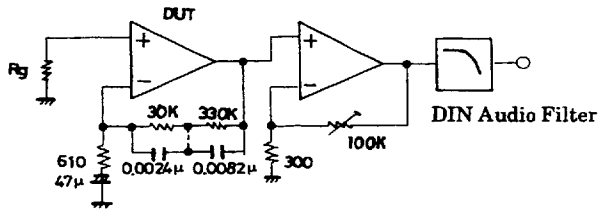

Unit (resistance: Ω , capacitance: F)

Pin Assignments

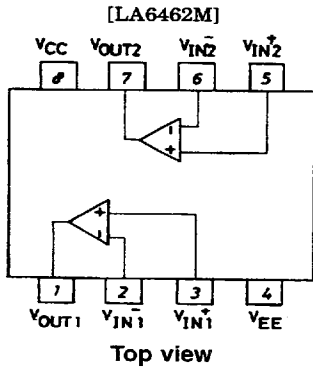

Top view

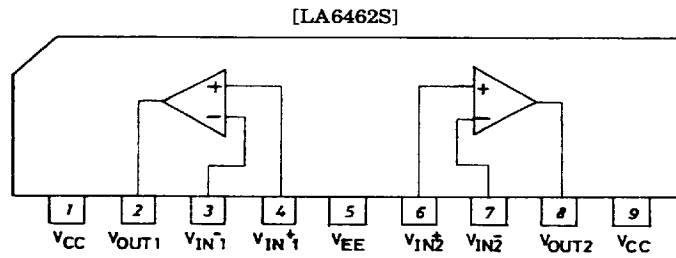

Top view

Equivalent Circuit

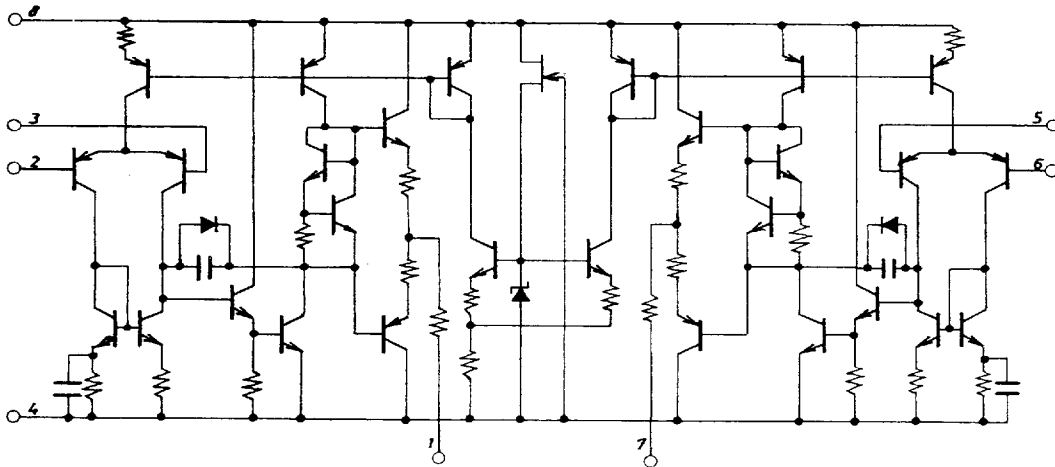

LA6462M, 6462S

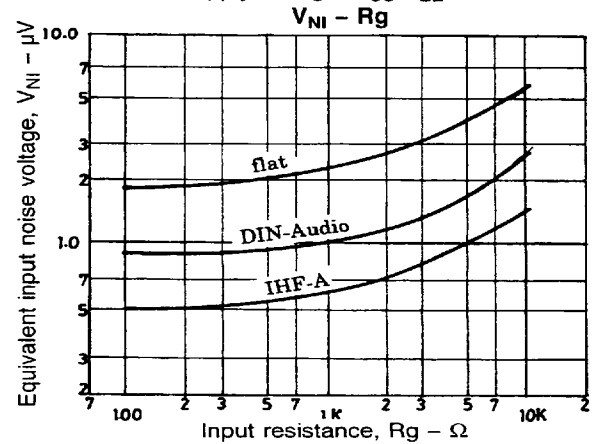
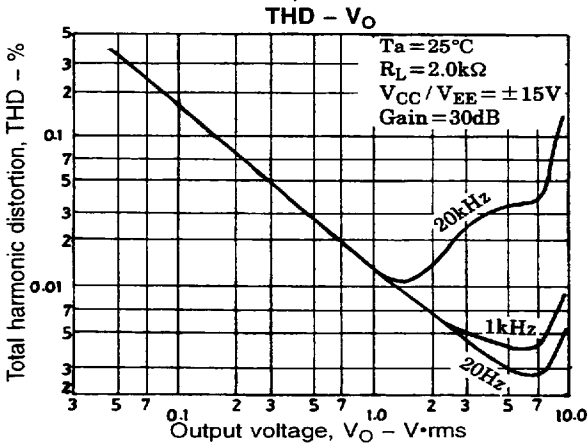
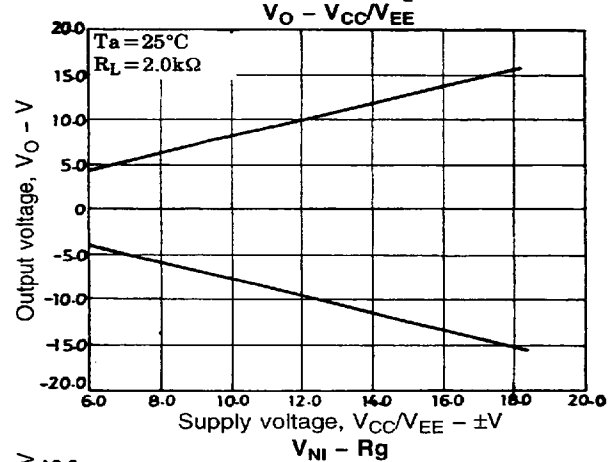
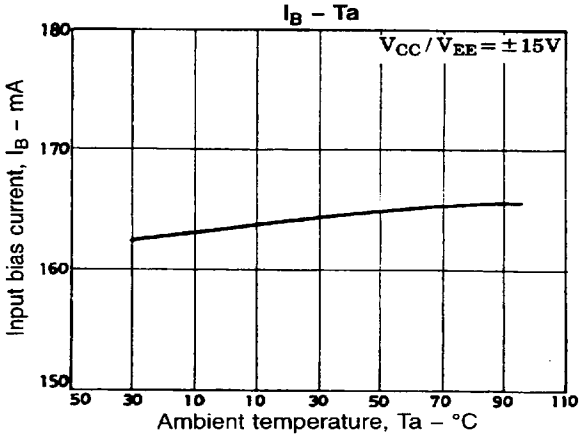
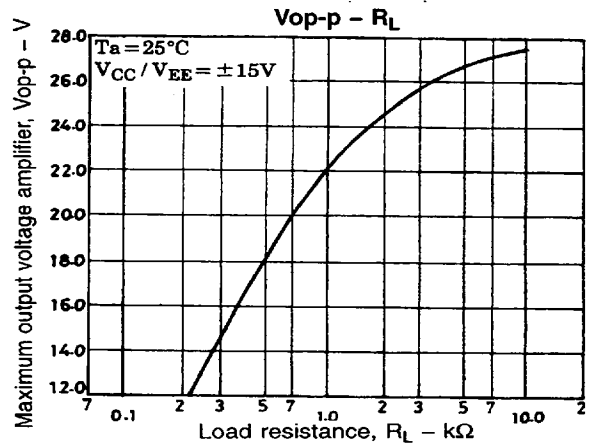
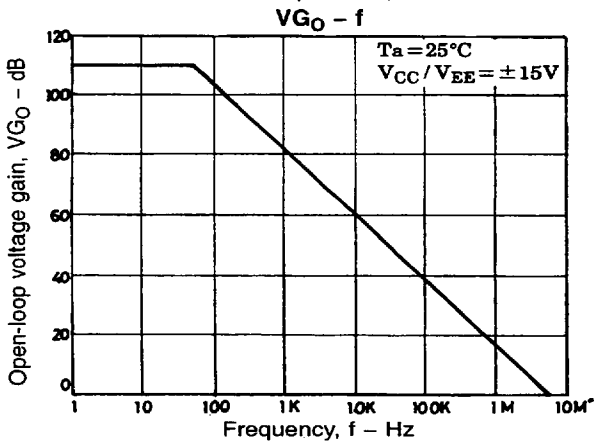
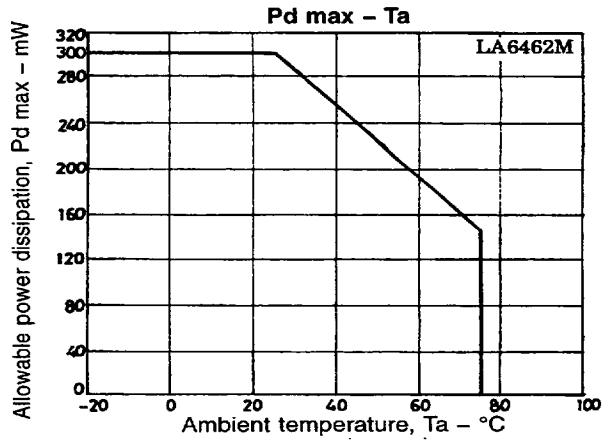
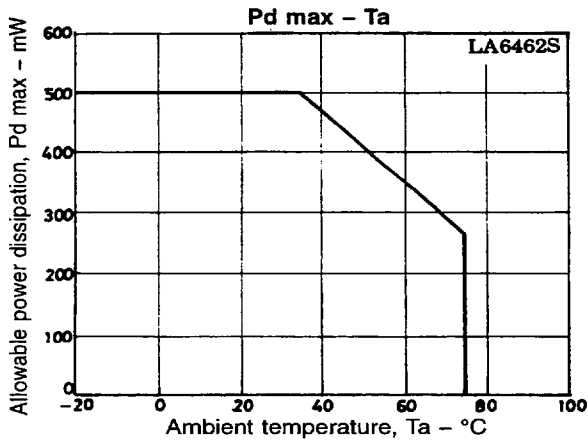

7997076 0016158 OTT

No.2064-4/5