

TOSHIBA PHOTOCOUPLER GaAs IRED & PHOTO-TRIAC

TLP666J

- OFFICE MACHINE
- HOUSEHOLD USE EQUIPMENT
- TRIAC DRIVER
- SOLID STATE RELAY

The TOSHIBA TLP666J consists of a zero voltage crossing turn-on photo-triac optically coupled to a gallium arsenide infrared emitting diode in a six lead plastic DIP.

- Peak Off-State Voltage : 600V (Min.)
- Trigger LED Current : 10mA (Max.)
- On-State Current : 100mA (Max.)
- UL Recognized : UL1577, File No. E67349
- Isolation Voltage : 5000V_{rms} (Min.)
- Option (D4) Type VDE Approved : DIN VDE0884 / 08.87, Certificate No. 68383

Maximum Operating Insulation Voltage : 630V_{PK}
 Highest Permissible Over Voltage : 6000V_{PK}

(Note 1) When a VDE0884 approved type is needed, please designate the "Option (D4)"

- Structural Parameter
 - Creepage Distance : 7.0mm (Min.)
 - Clearance : 7.0mm (Min.)
 - Insulation Thickness : 0.5mm (Min.)

Unit in mm

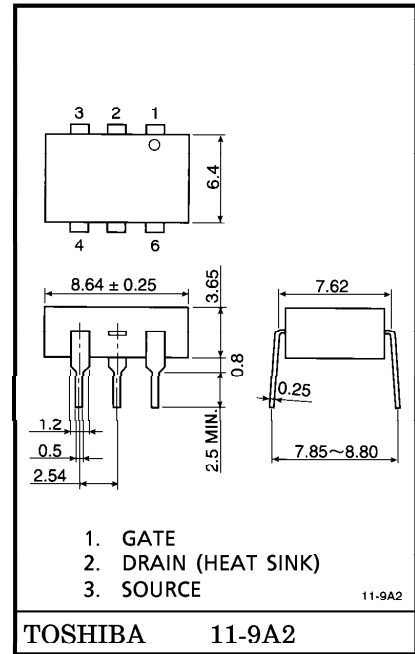

Weight : 0.44g

PIN CONFIGURATIONS (Top view)

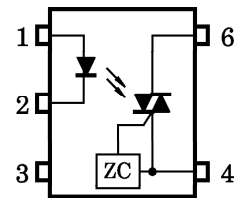

- 1 : ANODE
- 2 : CATHODE
- 3 : N.C.
- 4 : TERMINAL 1
- 6 : TERMINAL 2

961001EAA2

● TOSHIBA is continually working to improve the quality and the reliability of its products. Nevertheless, semiconductor devices in general can malfunction or fail due to their inherent electrical sensitivity and vulnerability to physical stress. It is the responsibility of the buyer, when utilizing TOSHIBA products, to observe standards of safety, and to avoid situations in which a malfunction or failure of a TOSHIBA product could cause loss of human life, bodily injury or damage to property. In developing your designs, please ensure that TOSHIBA products are used within specified operating ranges as set forth in the most recent products specifications. Also, please keep in mind the precautions and conditions set forth in the TOSHIBA Semiconductor Reliability Handbook.

● The information contained herein is presented only as a guide for the applications of our products. No responsibility is assumed by TOSHIBA CORPORATION for any infringements of intellectual property or other rights of the third parties which may result from its use. No license is granted by implication or otherwise under any intellectual property or other rights of TOSHIBA CORPORATION or others.

● The information contained herein is subject to change without notice.

MAXIMUM RATINGS (Ta = 25°C)

CHARACTERISTIC		SYMBOL	RATING	UNIT
LED	Forward Current	I_F	50	mA
	Forward Current Derating (Ta ≤ 53°C)	$\Delta I_F / ^\circ C$	-0.7	mA / °C
	Peak Forward Current (100μs Pulse, 100pps)	I_{FP}	1	A
	Reverse Voltage	V_R	5	V
	Junction Temperature	T_j	125	°C
DETECTOR	Off-State Output Terminal Voltage	V_{DRM}	600	V
	On-State RMS Current	Ta = 25°C	100	mA
		Ta = 70°C	50	
	On-State Current Derating (Ta ≥ 25°C)	$\Delta I_T / ^\circ C$	-1.1	mA / °C
	Peak On-State Current (100μs Pulse, 120pps)	I_{TP}	2	A
	Peak Nonrepetitive Surge Current (Pw = 10ms, DC = 10%)	I_{TSM}	1.2	A
	Junction Temperature	T_j	115	°C
Storage Temperature Range	T_{stg}	-55~125	°C	
Operating Temperature Range	T_{opr}	-40~100	°C	
Lead Soldering Temperature (10s)	T_{sol}	260	°C	
Isolation Voltage (AC, 1 min., R.H. ≤ 60%) (Note 2)	BVS	5000	V_{rms}	

(Note 2) Pins 1, 2 and 3 shorted together pin 4 and 6 shorted together.

RECOMMENDED OPERATING CONDITIONS

CHARACTERISTIC	SYMBOL	MIN.	TYP.	MAX.	UNIT
Supply Voltage	V_{AC}	—	—	240	Vac
Forward Current	I_F	15	20	25	mA
Peak On-Stage Current	I_{TP}	—	—	1	A
Operating Temperature	T_{opr}	-25	—	85	°C

INDIVIDUAL ELECTRICAL CHARACTERISTICS (Ta = 25°C)

CHARACTERISTIC		SYMBOL	TEST CONDITION	MIN.	TYP.	MAX.	UNIT
LED	Forward Voltage	V_F	$I_F = 10\text{mA}$	1.0	1.15	1.3	V
	Reverse Current	I_R	$V_R = 5\text{V}$	—	—	10	μA
	Capacitance	C_T	$V = 0, f = 1\text{MHz}$	—	30	—	pF
DETECTOR	Peak Off-State Current	I_{DRM}	$V_{DRM} = 600\text{V}$	—	10	1000	nA
	Peak On-State Voltage	V_{TM}	$I_{TM} = 100\text{mA}$	—	1.7	3.0	V
	Holding Current	I_H	—	—	0.6	—	mA
	Critical Rate of Rise of Off-State Voltage	dv/dt	$V_{in} = 240\text{V}, T_a = 85^\circ\text{C}$ (Note 3)	200	500	—	$\text{V}/\mu\text{s}$
	Critical Rate of Rise of Commutating Voltage	$dv/dt(c)$	$V_{in} = 60\text{V}_{\text{rms}}, I_T = 15\text{mA}$ (Note 3)	—	0.2	—	$\text{V}/\mu\text{s}$

(Note 3) dv/dt TEST CIRCUIT

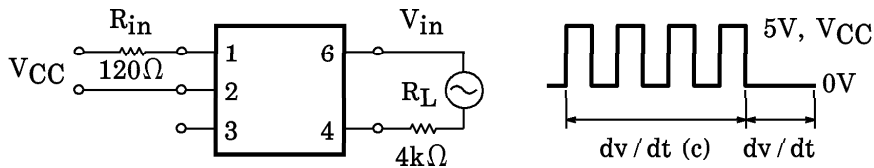

COUPLED ELECTRICAL CHARACTERISTICS (Ta = 25°C)

CHARACTERISTIC	SYMBOL	TEST CONDITION	MIN.	TYP.	MAX.	UNIT
Trigger LED Current	I_{FT}	$V_T = 6\text{V}$	—	5	10	mA
Inhibited Voltage	V_{IH}	$I_F = \text{Rated } I_{FT}$	—	—	50	V
Leakage in Inhibited State	I_{IH}	$I_F = \text{Rated } I_{FT}$ $V_T = \text{Rated } V_{DRM}$	—	200	600	μA
Capacitance (Input to Output)	C_S	$V_S = 0, f = 1\text{MHz}$	—	0.8	—	pF
Isolation Resistance	R_S	$V_S = 500\text{V}, \text{R.H.} \leq 60\%$	1×10^{12}	10^{14}	—	Ω
Isolation Voltage	BV_S	AC, 1 minute	5000	—	—	V_{rms}
		AC, 1 second, in oil	—	10000	—	
		DC, 1 minute, in oil	—	10000	—	Vdc

