

3046, 3056, AND 3058

HALL EFFECT GEAR-TOOTH SENSORS—ZERO SPEED

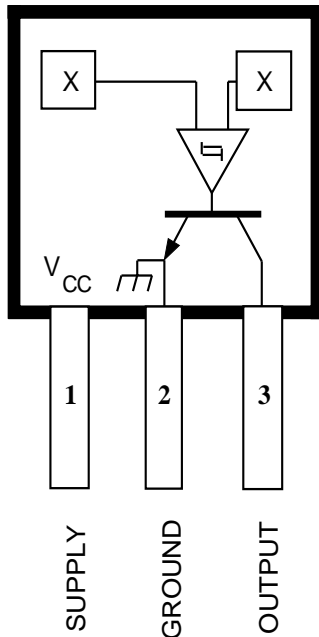

Dwg. PH-012

Pinning is shown viewed from branded side.

ABSOLUTE MAXIMUM RATINGS

Supply Voltage, V_{CC}	28 V
Reverse Battery Voltage, V_{RCC}	-30 V
Magnetic Flux Density, B	Unlimited
Output OFF Voltage, V_{OUT}	28 V
Reverse Output Voltage, V_{OUT}	-0.5 V
Output Current, I_{OUT}	25 mA
Package Power Dissipation, P_D ..	500 mW
Operating Temperature Range, T_A	
Suffix "EU"	-40°C to +85°C
Suffix "LU"	-40°C to +150°C
Storage Temperature Range, T_S	-65°C to +170°C

The A3046EU/LU, A3056EU/LU, and A3058EU/LU Hall effect gear-tooth sensors are monolithic integrated circuits that switch in response to differential magnetic fields created by ferrous targets. These devices are ideal for use in gear-tooth-based speed, position, and timing applications and operate down to zero rpm over a wide range of air gaps and temperatures. When combined with a back-biasing magnet and proper assembly techniques, devices can be configured to give 50% duty cycle or to switch on either leading, trailing, or both edges of a passing gear tooth or slot.

The six devices differ only in their magnetic switching values and operating temperature ranges. The low hysteresis of the A3046/56EU and A3046/56LU makes them perfectly suited for ABS (anti-lock brake system) or speed sensing applications where maintaining large air gaps is important. The A3046EU/LU features improved switch point stability with temperature over the A3056EU/LU. The high hysteresis of the A3058EU and A3058LU, with their excellent temperature stability, makes them especially suited to ignition timing applications where switch-point accuracy (and latching requirements) is extremely important.

Continued next page...

BENEFITS

- Senses Ferrous Targets Down to Zero RPM
- Large Effective Air Gap
- Wide Operating Temperature Range
- Operation from Unregulated Supply
- High-Speed Operation
- Output Compatible With All Logic Families
- Reverse Battery Protection
- Solid-State Reliability
- Resistant to Physical Stress

SELECTION GUIDE

	Switching Hysteresis, $B_{OP}-B_{RP}$	
	15-90 G	150-250 G
Operating Temp. Range	Device Type Number	
-40°C to +85°C	A3046EU A3056EU	A3058EU
-40°C to +150°C	A3046LU A3056LU	A3058LU

3046, 3056, AND 3058 HALL EFFECT GEAR-TOOTH SENSORS -ZERO SPEED

All devices, when used with a back-biasing magnet, can be configured to turn ON or OFF with the leading or trailing edge of a gear tooth or slot. Changes in fields on the magnet face caused by a moving ferrous mass are sensed by two integrated Hall transducers and are differentially amplified by on-chip electronics. The on-chip temperature compensation and Schmitt trigger circuitry minimizes shifts in effective working air gaps and switch points over temperature making these devices ideal for use in ignition timing, anti-lock braking systems, and speed measurement systems in hostile automotive and industrial environments.

Each Hall effect digital Integrated circuit includes two quadratic Hall effect sensing elements, a voltage regulator, temperature compensating circuitry, low-level amplifier, Schmitt trigger, and an open-collector output driver. The on-board regulator permits operation with supply voltages of 4.5 to 24 volts. The output stage can switch up to 20 mA at conservatively specified repetition rates to 20 kHz and is compatible with bipolar and MOS logic circuits.

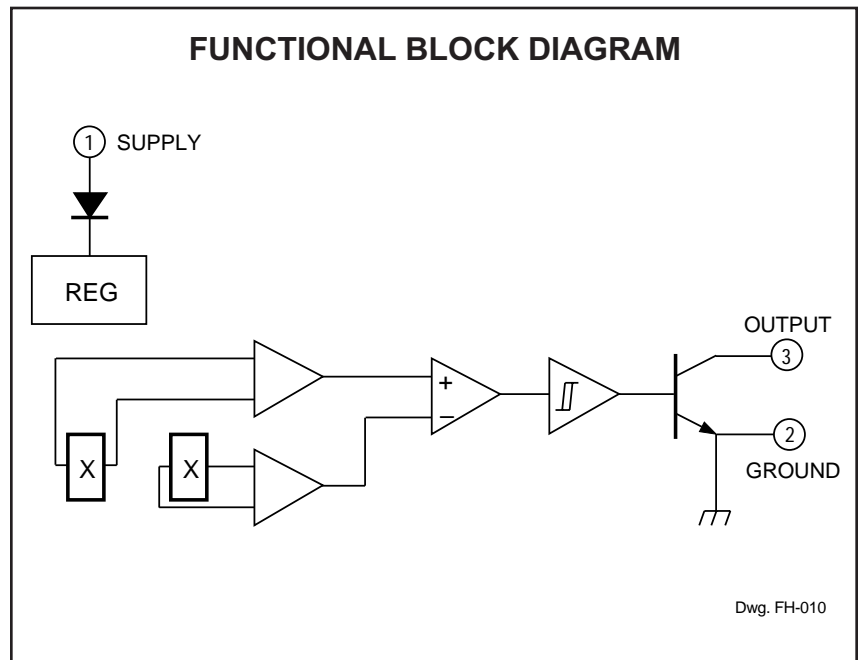

Both magnetic characteristics are available in a choice of two operating temperature ranges. Suffix EU devices have an operating range of -40°C to +85°C while suffix LU devices feature an operating range of -40°C to +150°C. All devices are packaged in a 3-pin plastic SIP.

ELECTRICAL CHARACTERISTICS at $V_{CC} = 8\text{ V}$, over operating temperature range.

Characteristic	Symbol	Test Conditions	Limits			
			Min.	Typ.	Max.	Units
Supply Voltage	V_{CC}	Operating	4.5	—	24	V
Power-Up State	—	3058* only, $V_{CC} = 0.14.5\text{ V}$, $B < B_{OP}$	Output is OFF			—
Output Saturation Voltage	$V_{OUT(SAT)}$	$I_{OUT} = 20\text{ mA}$, $B > B_{OP}$	—	135	400	mV
Output Leakage Current	I_{OFF}	$V_{CC} = V_{OUT} = 24\text{ V}$, $B < B_{RP}$	—	—	5.0	μA
Supply Current	I_{CC}	$V_{CC} = 24\text{ V}$, $B < B_{RP}$	—	7.2	14	mA
Output Rise time	t_r	$R_L = 820\ \Omega$, $C_L = 20\text{ pF}$	—	100	—	ns
Output Fall time	t_f	$R_L = 820\ \Omega$, $C_L = 20\text{ pF}$	—	100	—	ns

3046, 3056, AND 3058 HALL EFFECT GEAR-TOOTH SENSORS -ZERO SPEED

MAGNETIC CHARACTERISTICS in gauss at $V_{CC} = 8 V$.

Characteristic	Test Conditions	Part Numbers*								
		3046			3056			3058		
		Min.	Typ.	Max.	Min.	Typ.	Max.	Min.	Typ.	Max.
Operate Point, B_{OP}	Output Switches OFF to ON, $T_A = +25^\circ C$	—	—	150	—	—	150	—	—	250
Release Point, B_{RP}	Output Switches ON to OFF, $T_A = +25^\circ C$	-150	—	—	-150	—	—	-250	—	—
Hysteresis, B_{hys}	$B_{OP} - B_{RP}$, $T_A = +25^\circ C$	15	50	90	15	50	90	150	200	250
Change in Trip Point, ΔB_{OP} or ΔB_{RP}	Over operating temperature range, Ref. B_{OP} or B_{RP} at $T_A = +25^\circ C$	—	—	± 50	—	—	± 75	—	—	± 50

- NOTES: 1. Magnetic switch points are specified as the difference in magnetic fields at the two Hall elements.
 2. As used here, negative flux densities are defined as less than zero (algebraic convention).
 3. Typical values are at $T_A = +25^\circ C$.
 * Complete part number includes the prefix 'A' and a suffix to identify operating temperature range and package style. See selection guide.

TYPICAL OPERATING CHARACTERISTICS

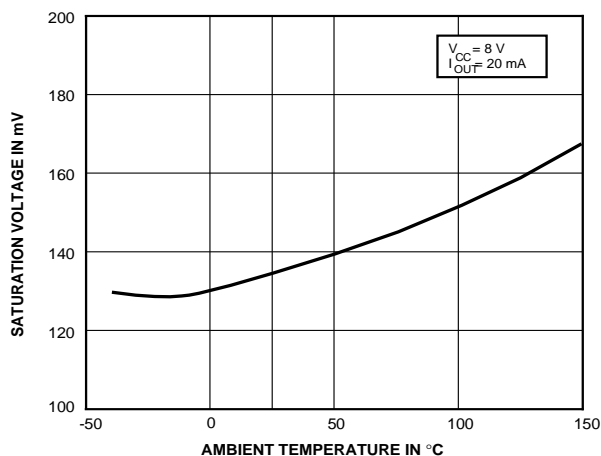

Dwg. GH-033

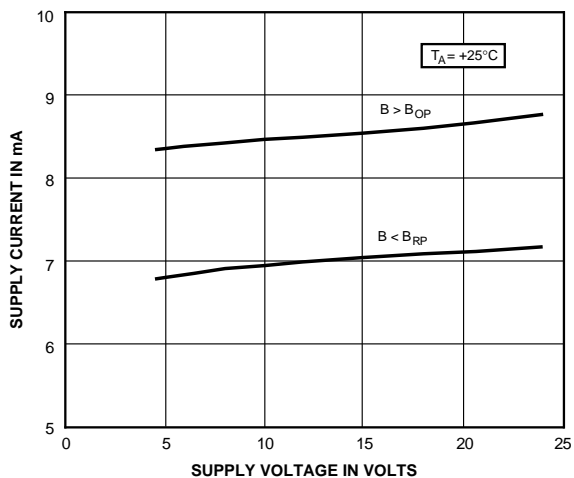

Dwg. GH-031

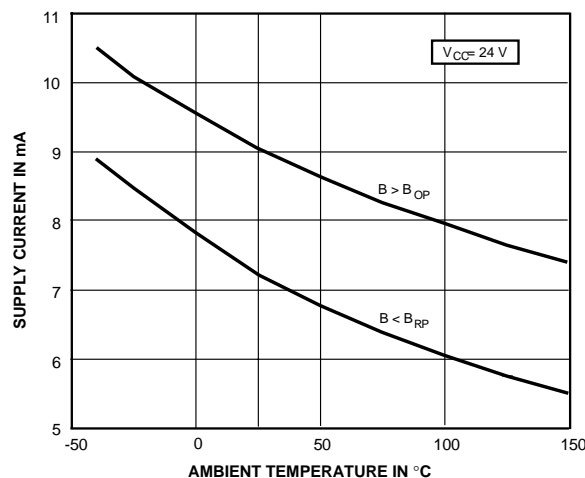

Dwg. GH-032

3046, 3056, AND 3058 HALL EFFECT GEAR-TOOTH SENSORS -ZERO SPEED

**Figure 1
TYPICAL GEAR-TOOTH SENSING
APPLICATION**

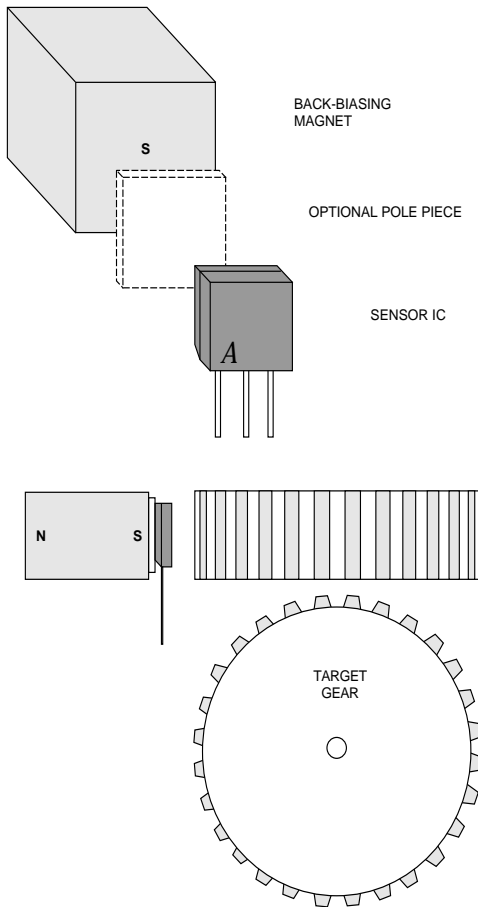

Dwg. AH-003

APPLICATIONS INFORMATION

A gear-tooth sensing system consists of the sensor IC, a back-biasing magnet, an optional pole piece, and a target (Figure 1). The system requirements are usually specified in terms of the effective working air gap between the package and the target (gear teeth), the number of switching events per rotation of the target, temperature and speed ranges, minimum pulse duration or duty cycle, and switch point accuracy. Careful choice of the sensor IC, magnet material and shape, target material and shape, and assembly techniques enables large working air gaps and high switch-point accuracy over the system operating temperature range.

Naming Conventions. With a south pole in front of the branded surface of the sensor, a north pole behind the sensor, the field at the sensor is defined as positive. As used here, negative flux densities are defined as less than zero (algebraic convention), e.g., -100 G is less than -50 G.

Magnet Biasing. In order to sense moving non-magnetized ferrous targets, these devices must be back-biased by mounting the unbranded side on a small permanent magnet. Either magnetic pole (north or south) can be used.

The devices can also be used without a back-biasing magnet. In this configuration, the sensor can be used to detect a rotating ring magnet such as those found in brushless dc motors or in speed sensing applications. Here, the sensor detects the magnetic field gradient created by the magnetic poles.

**Figure 2
TYPICAL TRANSFER CHARACTERISTIC**

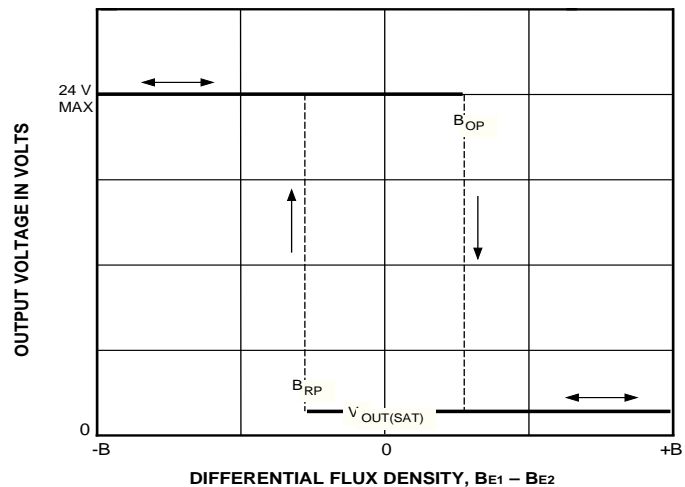

Dwg. GH-034

3046, 3056, AND 3058 HALL EFFECT GEAR-TOOTH SENSORS -ZERO SPEED

Sensor Operation. The A3046EU/LU, A3056EU/LU, and A3058EU/LU sensor ICs each contain two integrated Hall transducers (E1 and E2) that are used to sense a magnetic field differential across the face of the IC (see SENSOR LOCATION drawing). Referring to Figure 2, the trigger switches the output ON (output LOW) when $B_{E1} - B_{E2} > B_{OP}$ and switches the output OFF (output HIGH) when $B_{E1} - B_{E2} < B_{RP}$. The difference between B_{OP} and B_{RP} is the hysteresis of the device.

Figure 3 relates the output state of a back-biased sensor IC, with switching characteristics shown in Figure 2, to the target gear profile and position. Assume a north pole back-bias configuration (equivalent to south pole at the face of the device). The motion of the gear produces a phase-shifted field at E1 and E2 (Figure 3 (a)); internal conditioning circuitry subtracts the field at the two elements (Figure 3 (b)); and the Schmitt trigger at the output of the conditioning circuitry switches at the pre-determined thresholds (B_{OP} and B_{RP}). As shown (Figure 3 (c)), the IC output is LOW whenever sensor E1 sees a (ferrous) gear tooth and sensor E2 faces air. The output is HIGH when sensor E1 sees air and sensor E2 sees the ferrous target.

A gear-tooth sensor can be configured (see ASSEMBLY TECHNIQUES) to operate as a latch, a (positive) switch, or a negative switch. Note the change in duty cycle in each of the cases (Figure 4).

A **latch** is a device where the operate point is greater than zero gauss and the release point is less than zero gauss. With the configuration shown in Figure 3, such a device will switch ON on the leading edge and OFF on the trailing edge of the target tooth.

A **(positive) switch** is a device where both the operate and release points are greater than zero gauss (positive values). In the configuration shown in Figure 3, such a

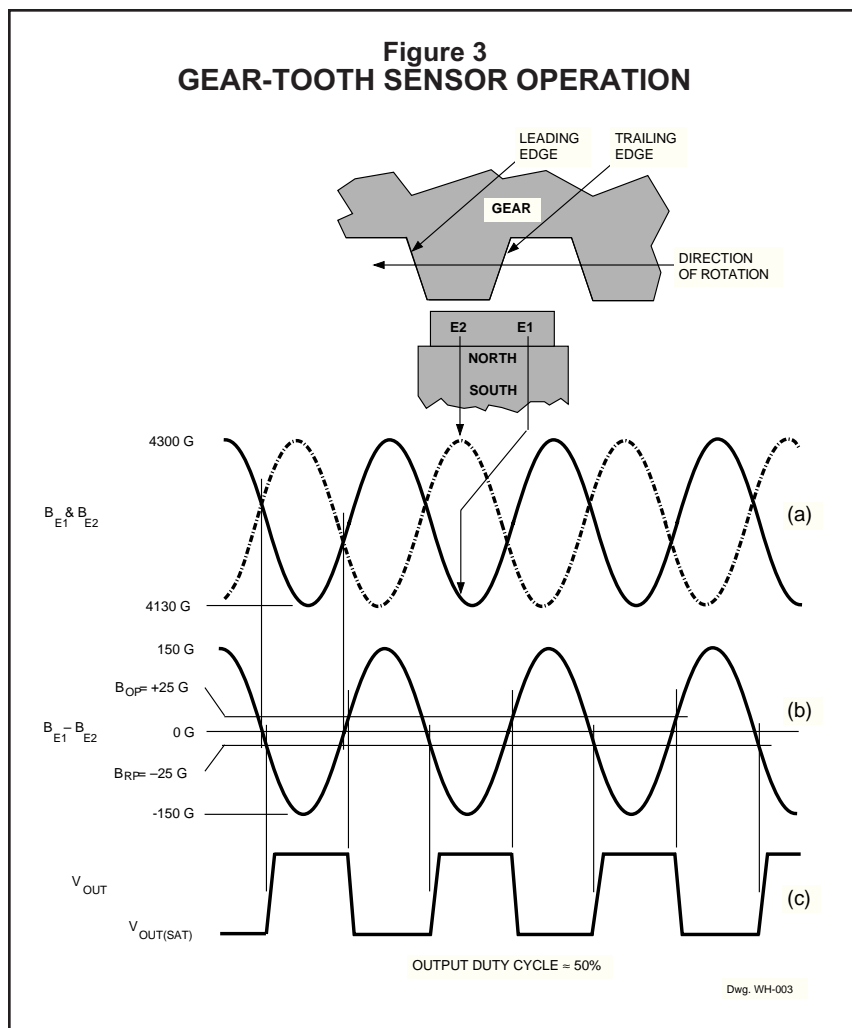

device will switch ON and then switch OFF on the leading or rising edge of the target tooth (Figure 4 (a)).

A **negative switch** is a device where both the operate and release points are less than zero gauss (negative values). In the configuration shown in Figure 3, such a device will switch OFF and then switch ON on the trailing or falling edge of the target tooth (Figure 4 (b)).

Speed sensors can use any of the three sensor configurations described. Timing sensors, however, must use a latch to guarantee dual-edge detection. Latches are most easily made using the A3058EU or A3058LU device types.

3046, 3056, AND 3058 HALL EFFECT GEAR-TOOTH SENSORS -ZERO SPEED

SYSTEM ISSUES

Optimal performance of a gear-tooth sensing system strongly depends on four factors: the IC magnetic parameters, the magnet, the pole piece configuration, and the target.

Sensor Specifications. Shown in Figure 5 are graphs of the differential field as a function of air gap. A 48-tooth, 2.5" (63.5 mm) diameter, uniform wheel similar to that used in ABS applications is used. The samarium cobalt magnet is 0.32" diameter by 0.20" long (8.13 x 5.08 mm). The maximum functioning air gap with this typical gear/magnet combination can be determined using the graphs and the specifications for the sensor IC.

In this case, if an A3056EU/LU sensor with a B_{OP} of +25 G and a B_{RP} of -25 G is used, the maximum allowable air gap would be 0.110" (2.79 mm). If the switch points change +75 G with temperature ($B_{OP} = +100$ G, $B_{RP} = +50$ G), the maximum air gap will be approximately 0.077" (1.96 mm).

All system issues should be translated back to such a profile to aid the prediction of system performance.

Magnet Selection. These devices can be used with a wide variety of commercially available permanent magnets. The selection of the magnet depends on the operational and environmental requirements of the sensing system. For systems that require high accuracy and large working airgaps or an extended temperature range, the usual magnet material of choice is rare earth samarium cobalt (SmCo). This magnet material has a high energy product and can operate over an extended temperature range. For systems that require low-cost solutions for an extended temperature range, Alnico-8 can be used. Due to its relatively low energy product, smaller operational airgaps can be expected. At this time, neodymium iron boron (NdFeB) is not a proven high-temperature performer; at temperatures above

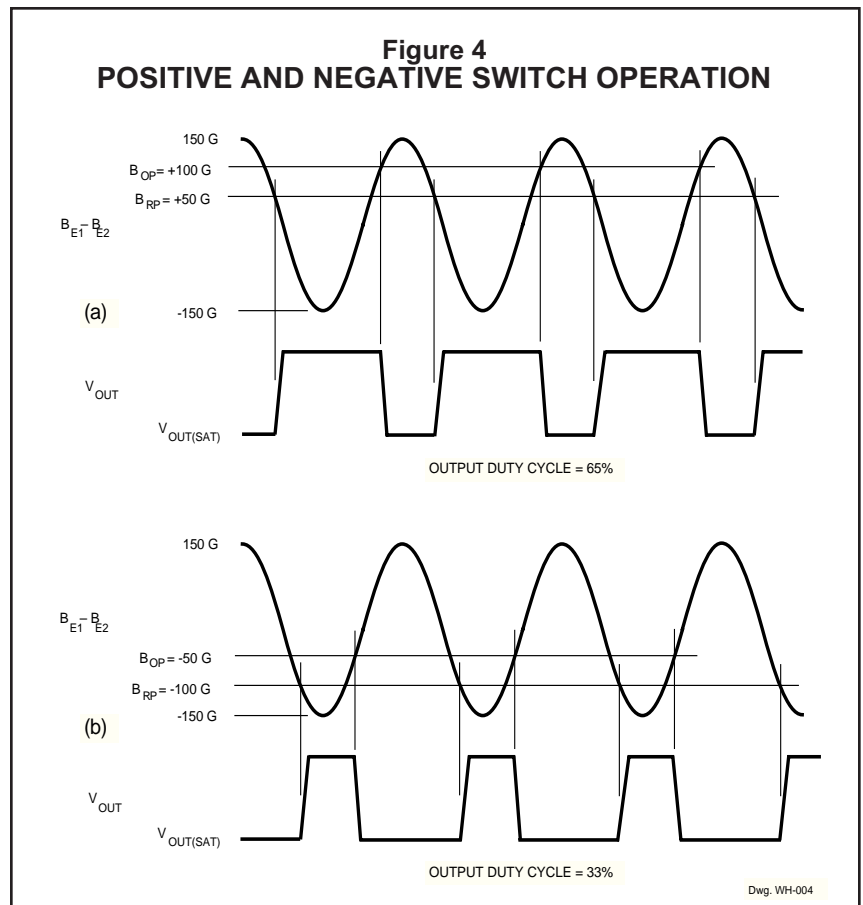

+150°C it may irreversibly lose magnetic strength. Of these three magnet materials, Alnico-8 is the least expensive by volume and SmCo is the most expensive.

Either cylindrical- or cube-shaped magnets can be used, as long as the magnet pole face at least equals the facing surface(s) of the IC package and the pole piece. Choose the length of the magnet to obtain a high length-to-width ratio, up to 0.75:1 for rare earths, or 1.5:1 for Alnico-8. Any added magnet length may incrementally improve the allowable maximum air gap.

Magnets, in general, have a non-uniform magnetic surface profile. The flux across the face of a magnet can vary by as much as 5% of the average field over a 0.10" (2.5 mm) region. If a Hall sensor is placed directly on a magnet face, the non-uniformity can appear to shift the operating parameters of the sensor. For example, if a device is placed on a 3000 G magnet with $\pm 2\%$ face offsets, each of the operating points might be shifted by ± 60 G. When offsets are present, the operating characteristics may be greatly altered.

3046, 3056, AND 3058 HALL EFFECT GEAR-TOOTH SENSORS -ZERO SPEED

**Figure 5
DIFFERENTIAL FLUX DENSITY**

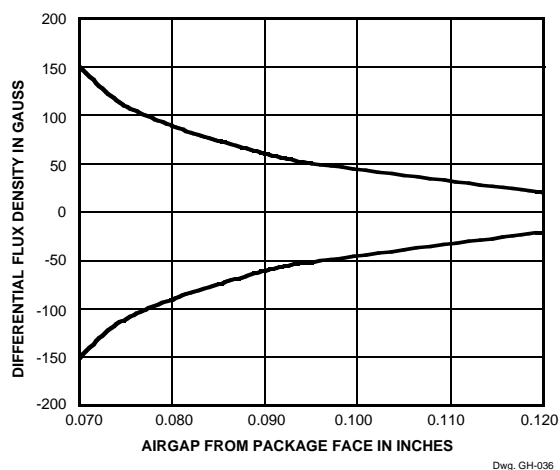
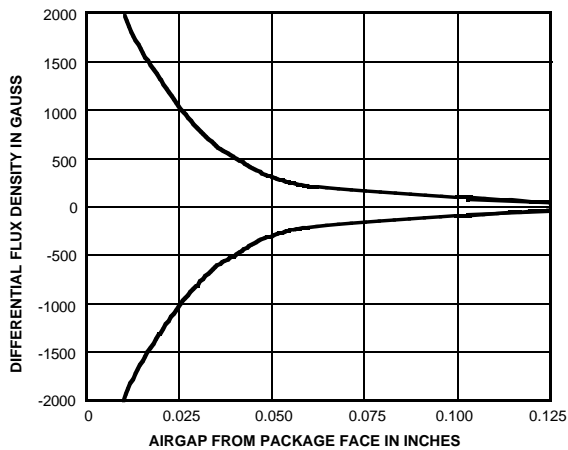

SENSOR LOCATIONS

(±0.005" [0.13 mm] die placement)

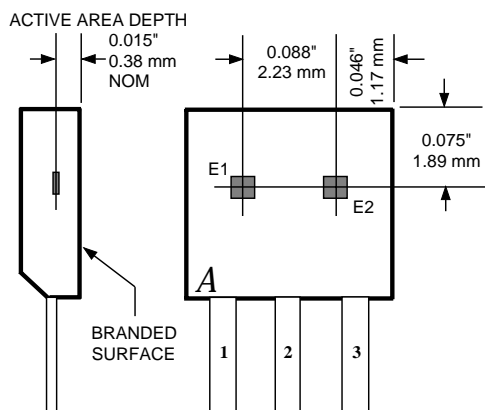

Dwg. MH-002-8D

Pole Piece Design. A pole piece may be used at the face of the magnet to smooth out the magnet-face offsets. A 0.020" (0.51 mm) thick, soft-iron pole piece will bring the field non-uniformity down to the ±1%-to-±3% range. Note that pole pieces will minimize but not eliminate the non-uniformity in the magnet face field. Front pole pieces will almost always result in a reduced maximum air gap.

Ferrous Targets. The best ferrous targets are made of cold-rolled low-carbon steel. Sintered-metal targets are also usable, but care must be taken to ensure uniform material composition and density.

The teeth or slots of the target should be cut with a slight angle so as to minimize the abruptness of transition from metal to air as the target passes by the sensor. Sharp transitions will result in magnetic overshoots that can result in false triggering.

Gear teeth larger than 0.10" (2.54 mm) wide and at least 0.10" (2.54 mm) deep provide reasonable working air gaps and adequate change in magnetic field for reliable switching. Generally, larger teeth and slots allow a larger air gap. A gear tooth width approximating the spacing between sensors (0.088" or 2.24 mm) requires special care in the system design and assembly techniques.

ASSEMBLY TECHNIQUES

Due to magnet face non-uniformities and device variations, it is recommended that applications requiring precision switching utilize a mechanical optimization procedure during assembly. Without a pole piece, the inherent magnet face offsets can be used to pre-bias the magnetic circuit to obtain any desired operating mode. This is achieved by physically changing the relative position of the magnet behind the sensor to achieve the desired system performance objective. For example, with a rotating ABS gear, the objective might be a 50% duty cycle at maximum air gap. Similar objectives can be set for ignition (crank and cam position) sensing systems.

Non-precision speed sensing applications do not require optimization. For applications where mechanical optimization is not feasible, non-zero speed devices such as the UGN/UGS3059KA ac-coupled gear-tooth sensor are available.

3046, 3056, AND 3058 HALL EFFECT GEAR-TOOTH SENSORS -ZERO SPEED

Dimensions in Inches (controlling dimensions)

Dimensions in Millimeters (for reference only)

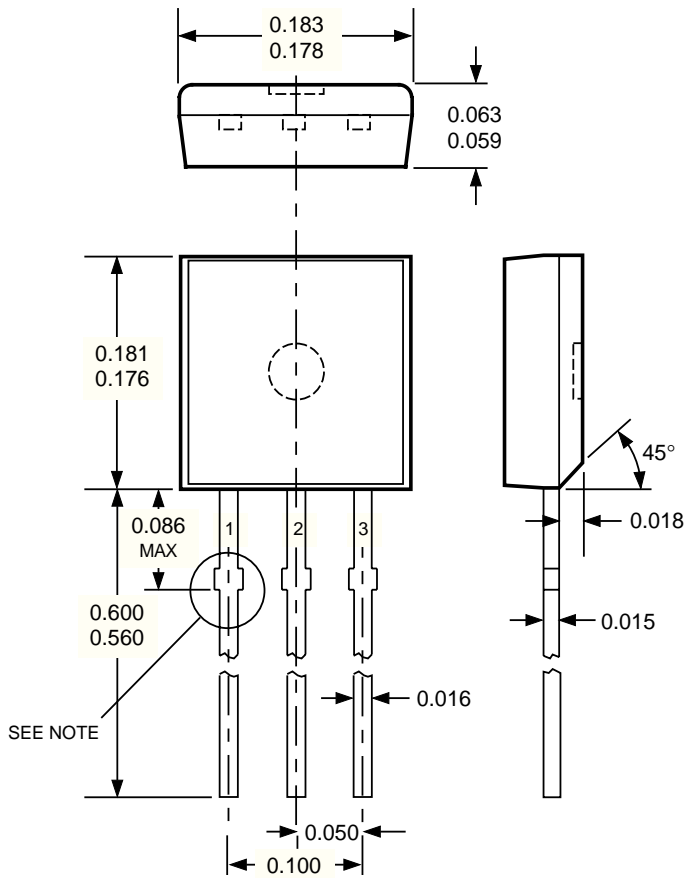

Dwg. MH-003D in

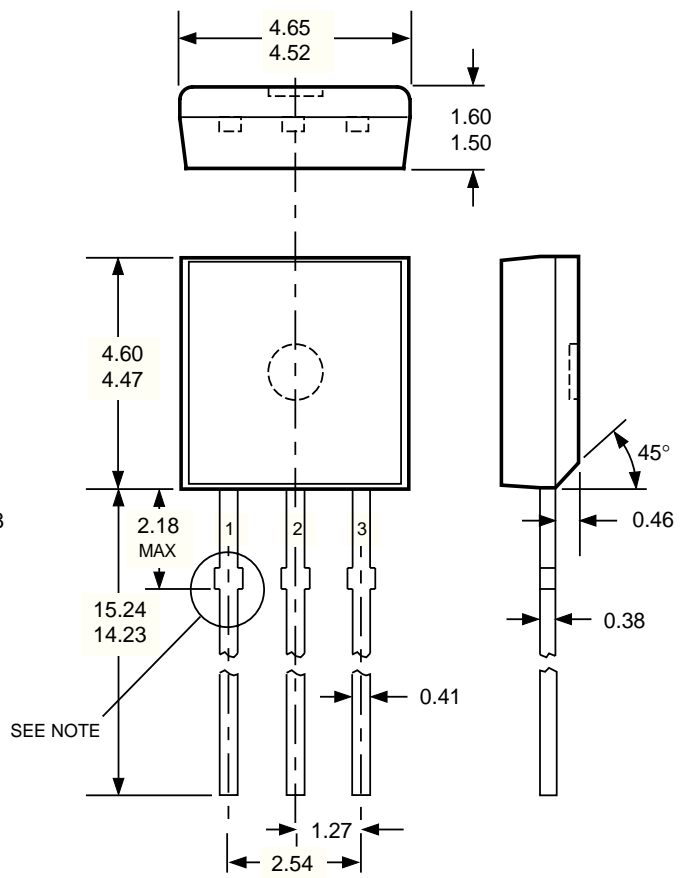

Dwg. MH-003D mm

Allegro MicroSystems, Inc. reserves the right to make, from time to time, such departures from the detail specifications as may be required to permit improvements in the design of its products.

The information included herein is believed to be accurate and reliable. However, Allegro MicroSystems, Inc. assumes no responsibility for its use; nor for any infringements of patents or other rights of third parties which may result from its use.

- NOTES:
1. Tolerances on package height and width represent allowable mold offsets. Dimensions given are measured at the widest point (parting line).
 2. Exact body and lead configuration at vendor's option within limits shown.
 3. Height does not include mold gate flash.
 4. Recommended minimum PWB hole diameter to clear transition area is 0.035" (0.89 mm).
 5. Where no tolerance is specified, dimension is nominal.
 6. Minimum lead length was 0.500" (12.70 mm). If existing product to the original specifications is not acceptable, contact sales office before ordering.