

PRODUCT SUMMARY

SKY74691: Receiver for CDMA Mobile Handset Applications

Applications

- Single mode CDMA handsets

Features

- Three-step gain control, cellular LNA
- External resistor to adjust LNA bias current
- Buffered LO signal for transmit upconverter
- VGA with 90 dB dynamic range
- Integrated IF VCO and tank circuit
- VCO_ON auto-tuning control
- Battery cell operation (2.7 V < VCC < 3.3 V)
- RFLGA™ (48-pin, 7 x 7 mm) Pb-free package (MSL3, 260 °C per JEDEC-J-STD-020) with downset paddle

Description

The SKY74691 is a highly integrated, super-heterodyne receiver. This single band receiver is intended for use in Code Division Multiple Access (CDMA) phones in cellular CDMA mode.

Except for the Surface Acoustic Wave (SAW) filters and matching components, the device incorporates all the components required to implement the receiver chain, from the Low-Noise Amplifier (LNA) to the In-Phase and Quadrature (I/Q) demodulator stages.

After RF LNA signal amplification and filtering from the antenna, the received signal is downconverted from RF to the Intermediate Frequency (IF).

The LO_IN signal (pin 39) provides a Local Oscillator (LO) port for the RF mixer. The UHF Voltage Controlled Oscillator (VCO) is buffered and amplified internally, and provides the LO to drive the LO port of a transmitter upconverter (such as Skyworks CX74002).

The Variable Gain Amplifier (VGA) has a minimum dynamic range of 90 dB with a control voltage range of 0.2 to 2.7 V. A VHF oscillator operates with an internal tank circuit to provide LO frequencies for the I/Q demodulator.

The noise figure, gain, and third order Input Intercept Point (IIP3) of each stage in the receiver are optimized to meet the system requirements for CDMA according to TIA/EIA-98-B/C. The design employs SiGe BiCMOS technology for low cost, high performance, and a high level of integration.

The device package and pinout for the 48-pin RF Land Grid Array (RFLGA) are shown in Figure 1 and a block diagram of the SKY74691 is shown in Figure 2.



Skyworks offers lead (Pb)-free “environmentally friendly” packaging that is RoHS compliant (European Parliament for the Restriction of Hazardous Substances).

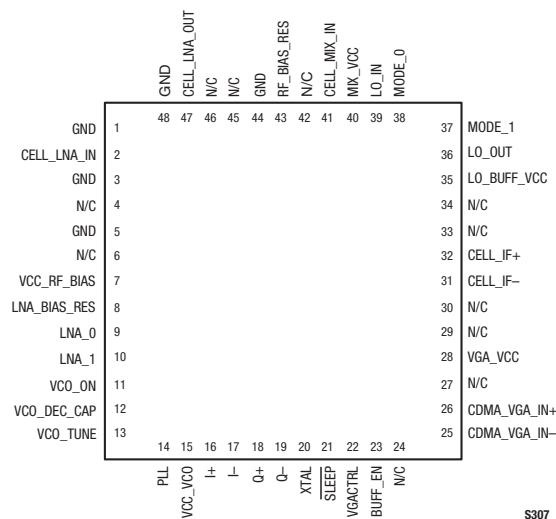

Figure 1. SKY74691 Pinout – 48-Pin RFLGA (Top View)

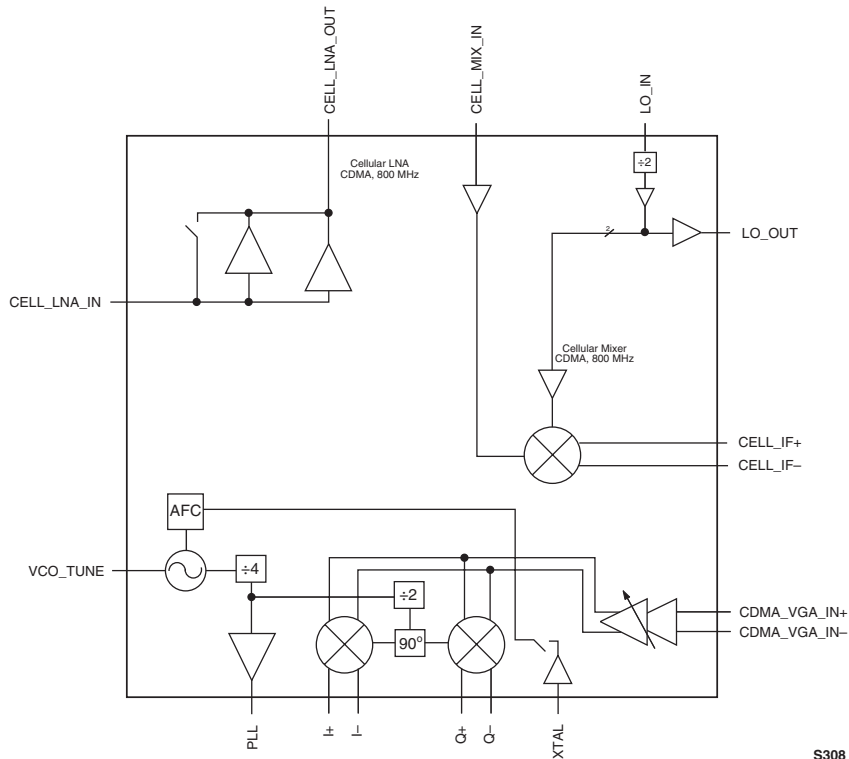

Figure 2. SKY74691 Receiver Block Diagram

Ordering Information

Model Name	Manufacturing Part Number	Product Revision
SKY74691 CDMA Receiver	SKY74691-11	

Copyright © 2003, 2004, 2005 Skyworks Solutions, Inc. All Rights Reserved.

Information in this document is provided in connection with Skyworks Solutions, Inc. ("Skyworks") products. These materials are provided by Skyworks as a service to its customers and may be used for informational purposes only by the customer. Skyworks assumes no responsibility for errors or omissions in these materials. Skyworks may make changes to its documentation, products, specifications and product descriptions at any time, without notice. Skyworks makes no commitment to update the information and shall have no responsibility whatsoever for conflicts, incompatibilities, or other difficulties arising from future changes to its documentation, products, specifications and product descriptions.

No license, express or implied, by estoppel or otherwise, to any intellectual property rights is granted by or under this document. Except as may be provided in Skyworks' Terms and Conditions of Sale for such products, Skyworks assumes no liability whatsoever in association with its documentation, products, specifications and product descriptions.

THESE MATERIALS ARE PROVIDED "AS IS" WITHOUT WARRANTY OF ANY KIND, EITHER EXPRESS OR IMPLIED OR OTHERWISE, RELATING TO SALE AND/OR USE OF SKYWORKS PRODUCTS INCLUDING WARRANTIES RELATING TO FITNESS FOR A PARTICULAR PURPOSE, MERCHANTABILITY, PERFORMANCE, QUALITY OR NON-INFRINGEMENT OF ANY PATENT, COPYRIGHT OR OTHER INTELLECTUAL PROPERTY RIGHT. SKYWORKS FURTHER DOES NOT WARRANT THE ACCURACY OR COMPLETENESS OF THE INFORMATION, TEXT, GRAPHICS OR OTHER ITEMS CONTAINED WITHIN THESE MATERIALS. SKYWORKS SHALL NOT BE LIABLE FOR ANY DAMAGES, INCLUDING SPECIAL, INDIRECT, INCIDENTAL, OR CONSEQUENTIAL DAMAGES, INCLUDING WITHOUT LIMITATION, LOST REVENUES OR LOST PROFITS THAT MAY RESULT FROM THE USE OF THESE MATERIALS WHETHER OR NOT THE RECIPIENT OF MATERIALS HAS BEEN ADVISED OF THE POSSIBILITY OF SUCH DAMAGE.

Skyworks products are not intended for use in medical, lifesaving or life-sustaining applications. Skyworks' customers using or selling Skyworks products for use in such applications do so at their own risk and agree to fully indemnify Skyworks for any damages resulting from such improper use or sale.

The following are trademarks of Skyworks Solutions, Inc.: Skyworks®, the Skyworks logo, and Breakthrough Simplicity®. Product names or services listed in this publication are for identification purposes only, and may be trademarks of Skyworks or other third parties. Third-party brands and names are the property of their respective owners. Additional information, posted at www.skyworksinc.com, is incorporated by reference.