

# 1

## PRODUCT OVERVIEW

### OVERVIEW

The S3C72N8/C72N5 single-chip CMOS microcontroller has been designed for high performance using Samsung's newest 4-bit CPU core, SAM47 (Samsung Arrangeable Microcontrollers).

With features such as LCD direct drive capability, 8-bit timer/counter, and serial I/O, the S3C72N8/C72N5 offer an excellent design solution for a wide variety of applications that require LCD functions.

Up to 40 pins of the 80-pin QFP package can be dedicated to I/O. Six vectored interrupts provide fast response to internal and external events. In addition, the S3C72N8/C72N5's advanced CMOS technology provides for low power consumption and a wide operating voltage range.

### OTP

The S3C72N8/C72N5 microcontroller is also available in OTP (One Time Programmable) version, S3P72N8/P72N5. S3P72N8/P72N5 microcontroller has an on-chip 8/16-Kbyte one-time-programmable EPROM instead of masked ROM. The S3P72N8/P72N5 is comparable to S3C72N8/C72N5, both in function and in pin configuration.

## FEATURES

### Memory

- 512 × 4-bit RAM
- 8 K × 8-bit ROM (S3C72N8/P72N8)
- 16 K × 8-bit ROM (S3C72N5/P72N5)

### I/O Pins

- Input only: 8 pins
- I/O: 24 pins
- Output: 8 pins sharing with segment driver outputs

### LCD Controller/Driver

- Maximum 16-digit LCD direct drive capability
- 32 segment, 4 common pins
- Display modes: Static, 1/2 duty (1/2 bias), 1/3 duty (1/2 or 1/3 bias), 1/4 duty (1/3 bias)

### 8-Bit Basic Timer

- Programmable interval timer
- Watchdog timer

### 8-Bit Timer/Counter 0

- Programmable 8-bit timer
- External event counter
- Arbitrary clock frequency output
- Serial I/O interface clock generator

### Watch Timer

- Real-time and interval time measurement
- Four frequency outputs to BUZ pin
- Clock source generation for LCD

### 8-Bit Serial I/O Interface

- 8-bit transmit/receive mode
- 8-bit receive only mode
- LSB-first or MSB-first transmission selectable
- Internal or external clock source

### Bit Sequential Carrier

- Support 16-bit serial data transfer in arbitrary format

### Interrupts

- Three internal vectored interrupts
- Three external vectored interrupts
- Two quasi-interrupts

### Memory-Mapped I/O Structure

- Data memory bank 15

### Two Power-Down Modes

- Idle mode (only CPU clock stops)
- Stop mode (main or sub system oscillation stops)

### Oscillation Sources

- Crystal, ceramic, or RC for main system clock
- Crystal or external oscillator for subsystem clock
- Main system clock frequency: 4.19 MHz (typical)
- Subsystem clock frequency: 32.768 kHz
- CPU clock divider circuit (by 4, 8, or 64)

### Instruction Execution Times

- 0.95, 1.91, 15.3 μs at 4.19 MHz (main)
- 122 μs at 32.768 kHz (subsystem)

### Operating Temperature

- –40 °C to 85 °C

### Operating Voltage Range

- 1.8 V to 5.5 V

### Package Type

- 80-pin QFP

BLOCK DIAGRAM

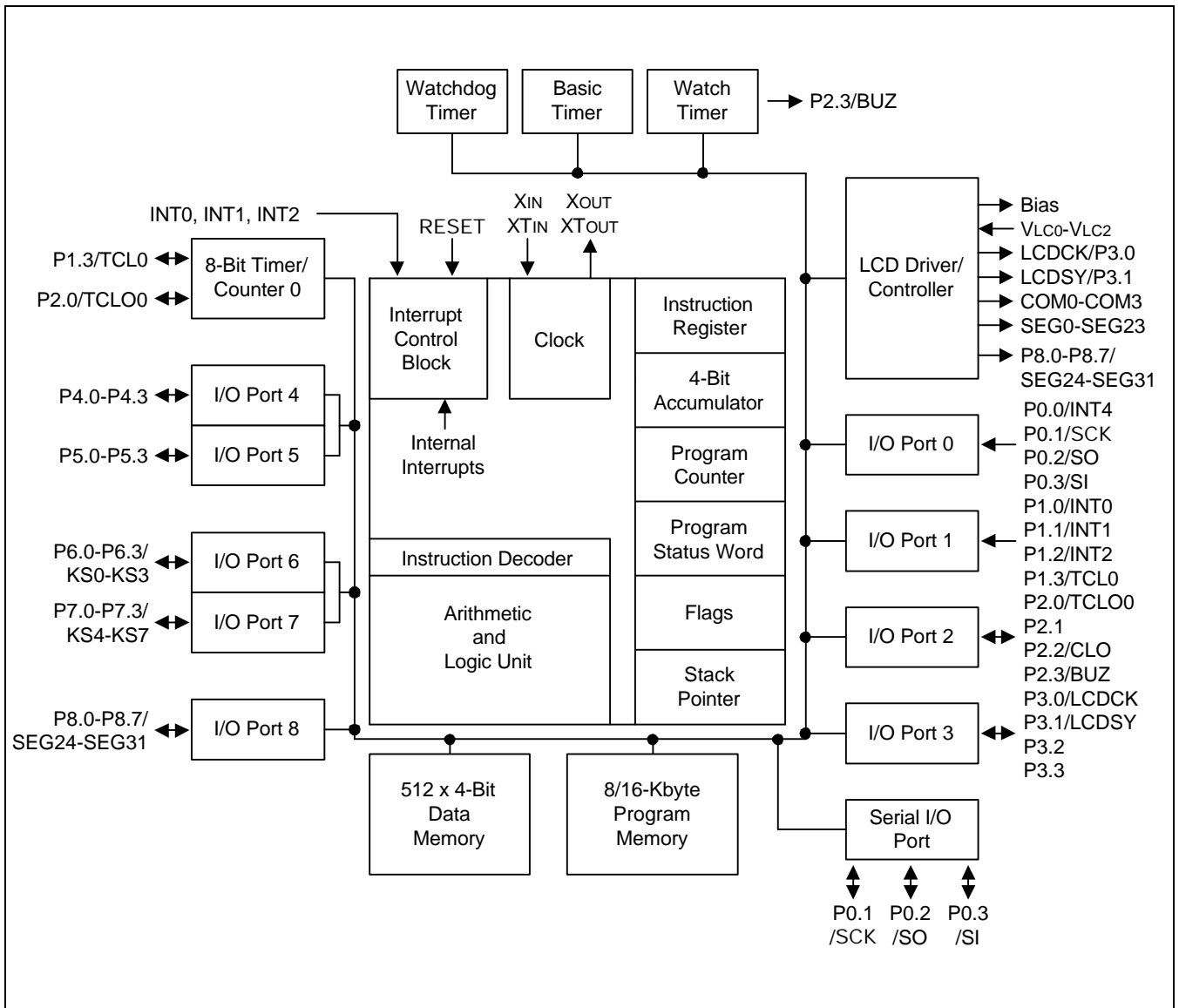

Figure 1-1. S3C72N8/C72N5 Simplified Block Diagram

PIN ASSIGNMENTS

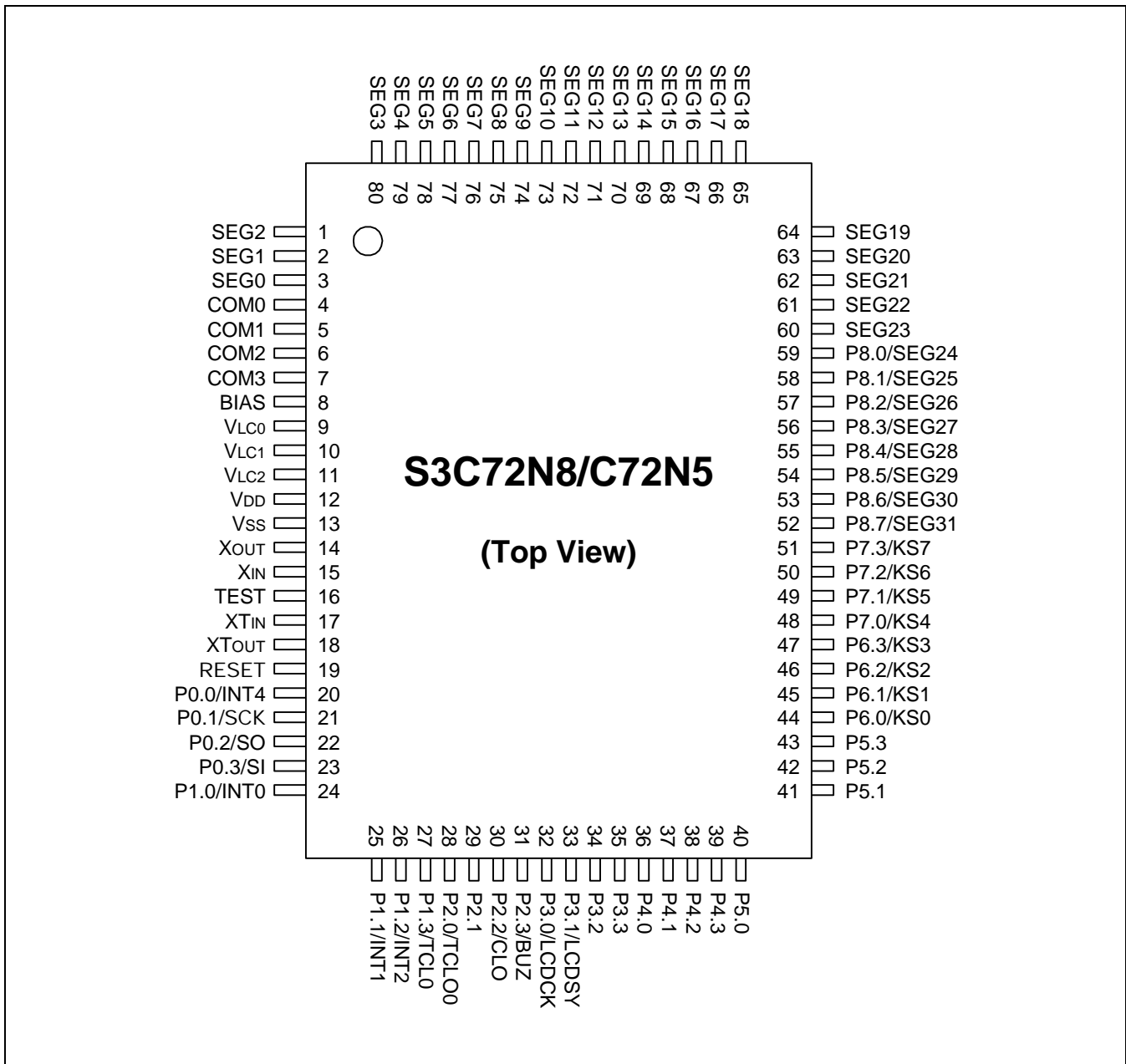

Figure 1-2. S3C72N8/C72N5 80-QFP Pin Assignment Diagram

## PIN DESCRIPTIONS

Table 1-1. S3C72N8/C72N5 Pin Descriptions

Pin Name	Pin Type	Description	Number	Share Pin	Reset Value	Circuit Type
P0.0	I	4-bit input port.	20	INT4	Input	A-1
P0.1	I/O	1-bit and 4-bit read and test are possible.	21	SCK		D *
P0.2	I/O	4-bit pull-up resistors are software assignable.	22	SO		D *
P0.3	I		23	SI		A-1
P1.0	I	4-bit input port.	24	INT0	Input	A-1
P1.1		1-bit and 4-bit read and test are possible.	25	INT1		
P1.2		4-bit pull-up resistors are software assignable.	26	INT2		
P1.3			27	TCL0		
P2.0	I/O	4-bit I/O port.	28	TCL00	Input	D
P2.1		1-bit and 4-bit read/write and test are possible.	29	–		
P2.2		4-bit pull-up resistors are software assignable.	30	CLO		
P2.3			31	BUZ		
P3.0	I/O	4-bit I/O port.	32	LCDCK	Input	D
P3.1		1-bit and 4-bit read/write and test are possible.	33	LCDSY		
P3.2		Each individual pin can be specified as input or output. 4-bit pull-up resistors are software assignable.	34			
P3.3			35			
P4.0– P4.3 P5.0– P5.3	I/O	4-bit I/O ports. N-channel open-drain output up to 5 V. 1-, 4-, and 8-bit read/write and test are possible. Ports 4 and 5 can be paired to support 8-bit data transfer. 4-bit pull-up resistors are software assignable.	36–43	–	Input	E
P6.0– P6.3 P7.0– P7.3	I/O	4-bit I/O ports. Port 6 pins are individually software configurable as input or output. 1-bit and 4-bit read/write and test are possible. 4-bit pull-up resistors are software assignable. Ports 6 and 7 can be paired to enable 8-bit data transfer.	44–51	KS0–KS3 KS4–KS7	Input	D *
P8.0– P8.7	O	Output port for 1-bit data (for use as CMOS driver only)	59–52	SEG24– SEG31	Output	H-16
SEG0– SEG23	O	LCD segment signal output	3–1, 80–60	–	Output	H-15
SEG24– SEG31	O	LCD segment signal output	59–52	P8.0–P8.7	Output	H-16
COM0– COM3	O	LCD common signal output	4–7	–	Output	H-15
V <sub>LC0</sub> –V <sub>LC2</sub>	–	LCD power supply. Voltage dividing resistors are assignable by mask option	9–11	SCLK SDAT	–	–
BIAS	–	LCD power control	8	–	–	–
LCDCK	I/O	LCD clock output for display expansion	32	P3.0	Input	D

Table 1-1. S3C72N8/C72N5 Pin Descriptions (Continued)

Pin Name	Pin Type	Description	Number	Share Pin	Reset Value	Circuit Type
LCDSY	I/O	LCD synchronization clock output for LCD display expansion	33	P3.1	Input	D
TCL0	I/O	External clock input for timer/counter 0	27	P1.3	Input	A-1
TCLO0	I/O	Timer/counter 0 clock output	28	P2.0	Input	D
SI	I	Serial interface data input	23	P0.3	Input	A-1
SO	I/O	Serial interface data output	22	P0.2	Input	D *
SCK	I/O	Serial I/O interface clock signal	21	P0.1	Input	D *
INT0 INT1	I	External interrupts. The triggering edge for INT0 and INT1 is selectable. Only INT0 is synchronized with the system clock.	24 25	P1.0 P1.1	Input	A-1
INT2	I	Quasi-interrupt with detection of rising edge signals.	26	P1.2	Input	A-1
INT4	I	External interrupt input with detection of rising or falling edge	20	P0.0	Input	A-1
KS0–KS7	I/O	Quasi-interrupt inputs with falling edge detection.	44–51	P6.0–P7.3	Input	D *
CLO	I/O	CPU clock output	30	P2.2	Input	D
BUZ	I/O	2, 4, 8 or 16 kHz frequency output for buzzer sound with 4.19 MHz main system clock or 32.768 kHz subsystem clock.	31	P2.3	Input	D
X <sub>IN</sub> , X <sub>OUT</sub>	–	Crystal, ceramic or RC oscillator pins for main system clock. (For external clock input, use X <sub>IN</sub> and input X <sub>IN</sub> 's reverse phase to X <sub>OUT</sub> )	15,14	–	–	–
XT <sub>IN</sub> , XT <sub>OUT</sub>	–	Crystal oscillator pins for subsystem clock. (For external clock input, use XT <sub>IN</sub> and input XT <sub>IN</sub> 's reverse phase to XT <sub>OUT</sub> )	17,18	–	–	–
V <sub>DD</sub>	–	Main power supply	12	–	–	–
V <sub>SS</sub>	–	Ground	13	–	–	–
RESET	–	Reset signal	19	–	Input	B
TEST	–	Test signal input (must be connected to V <sub>SS</sub> )	16	–	–	–

**NOTES:**

1. Pull-up resistors for all I/O ports are automatically disabled if they are configured to output mode.
2. D \* Type has a schmitt trigger circuit at input.

**PIN CIRCUIT DIAGRAMS**

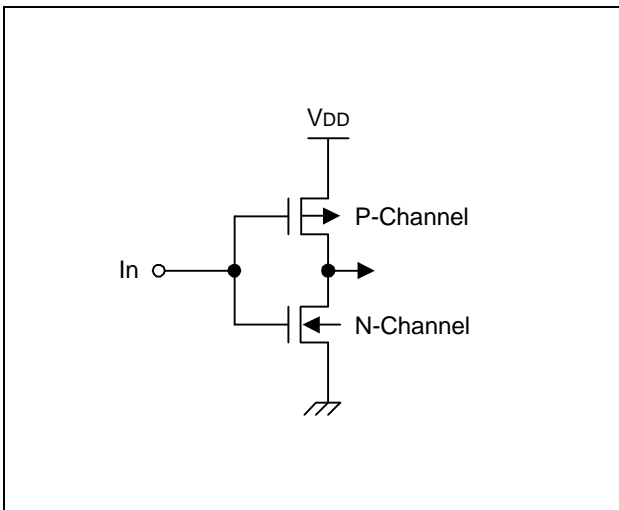

**Figure 1-3. Pin Circuit Type A**

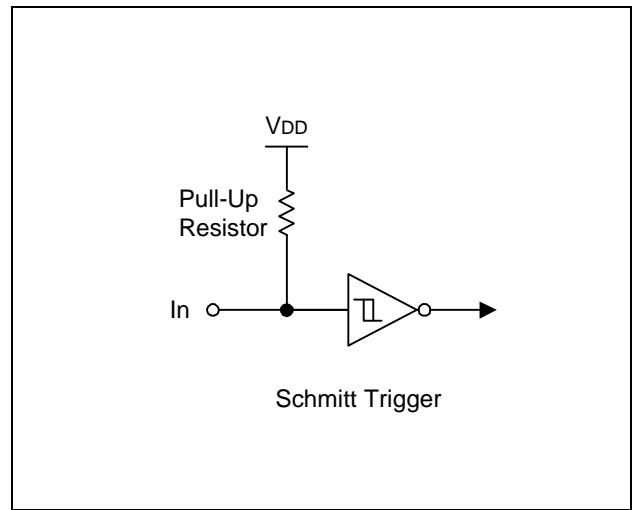

**Figure 1-5. Pin Circuit Type B (RESET)**

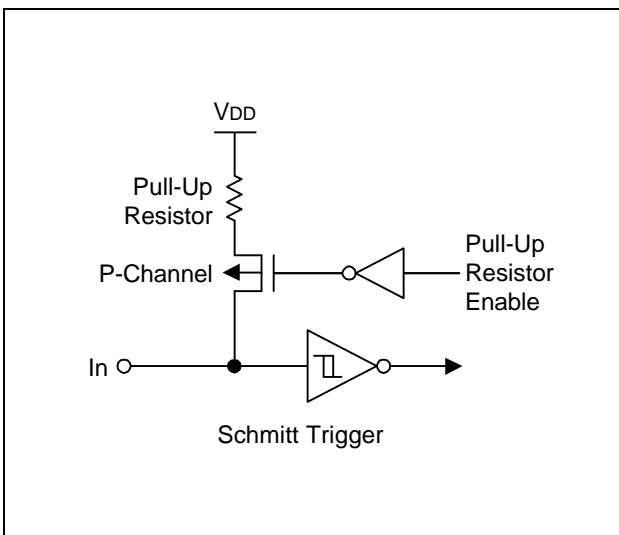

**Figure 1-4. Pin Circuit Type A-1 (P1, P0.0, P0.3)**

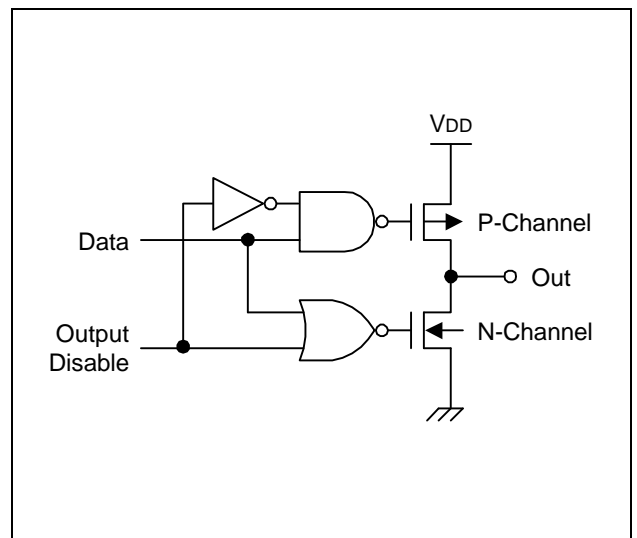

**Figure 1-6. Pin Circuit Type C**

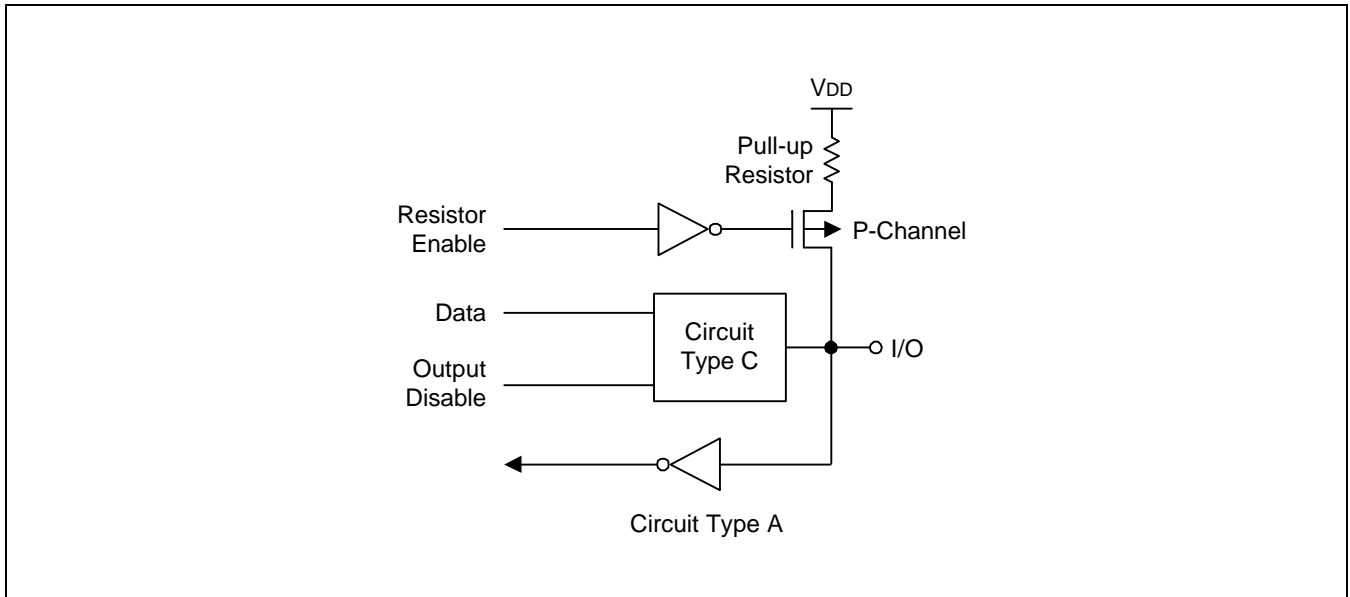

Figure 1-7. Pin Circuit Type D (P0.1, P0.2, P2, P3, P6, P7)

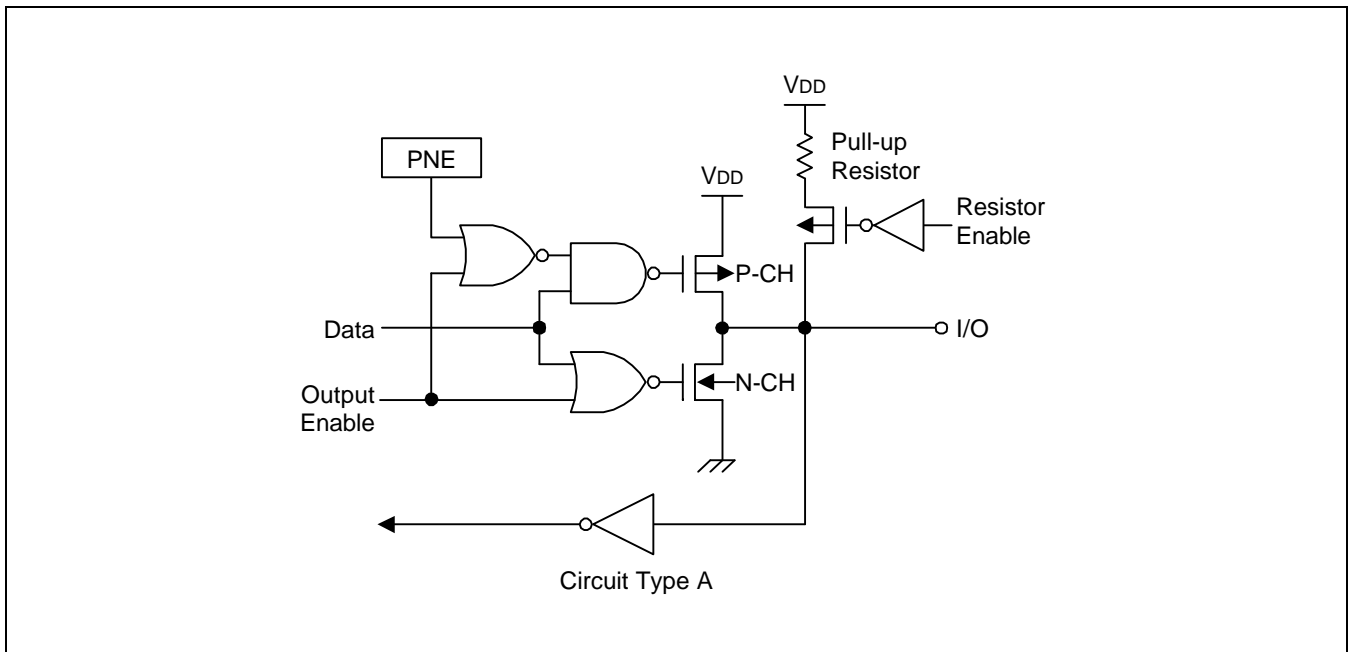

Figure 1-8. Pin Circuit Type E (P4, P5)



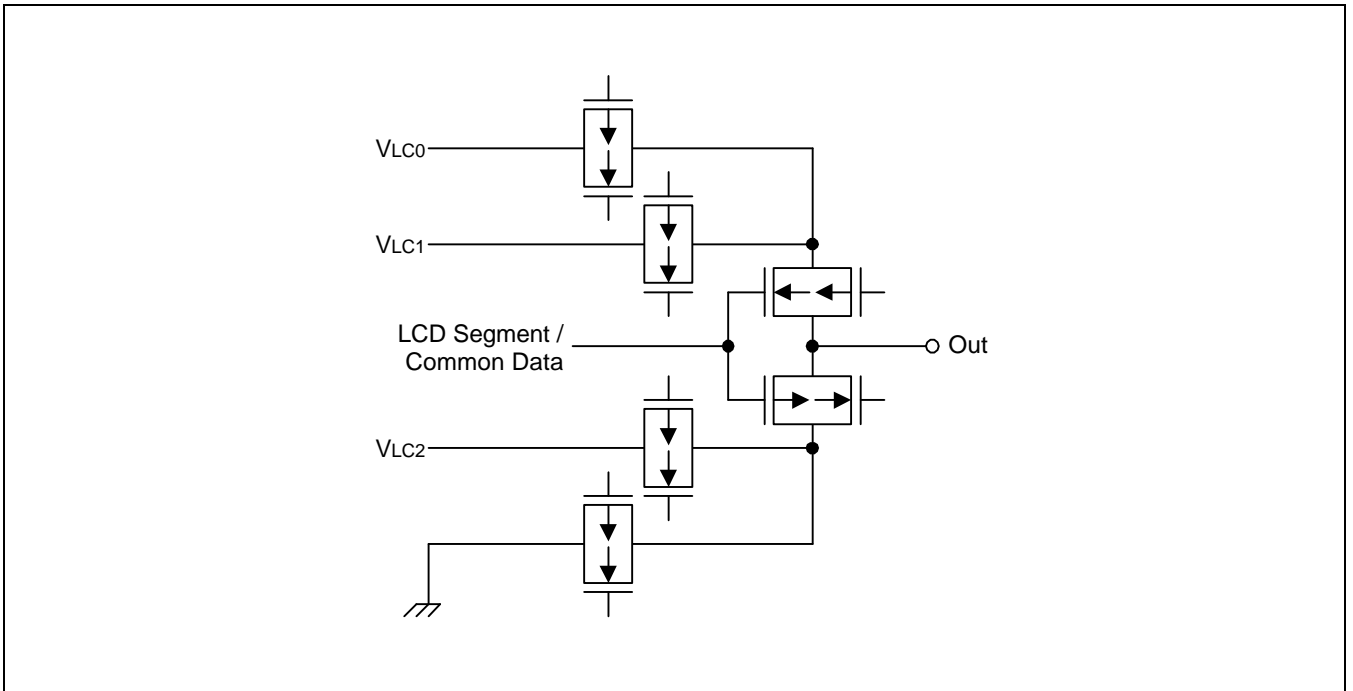

Figure 1-9. Pin Circuit Type H-15 (SEG/COM)

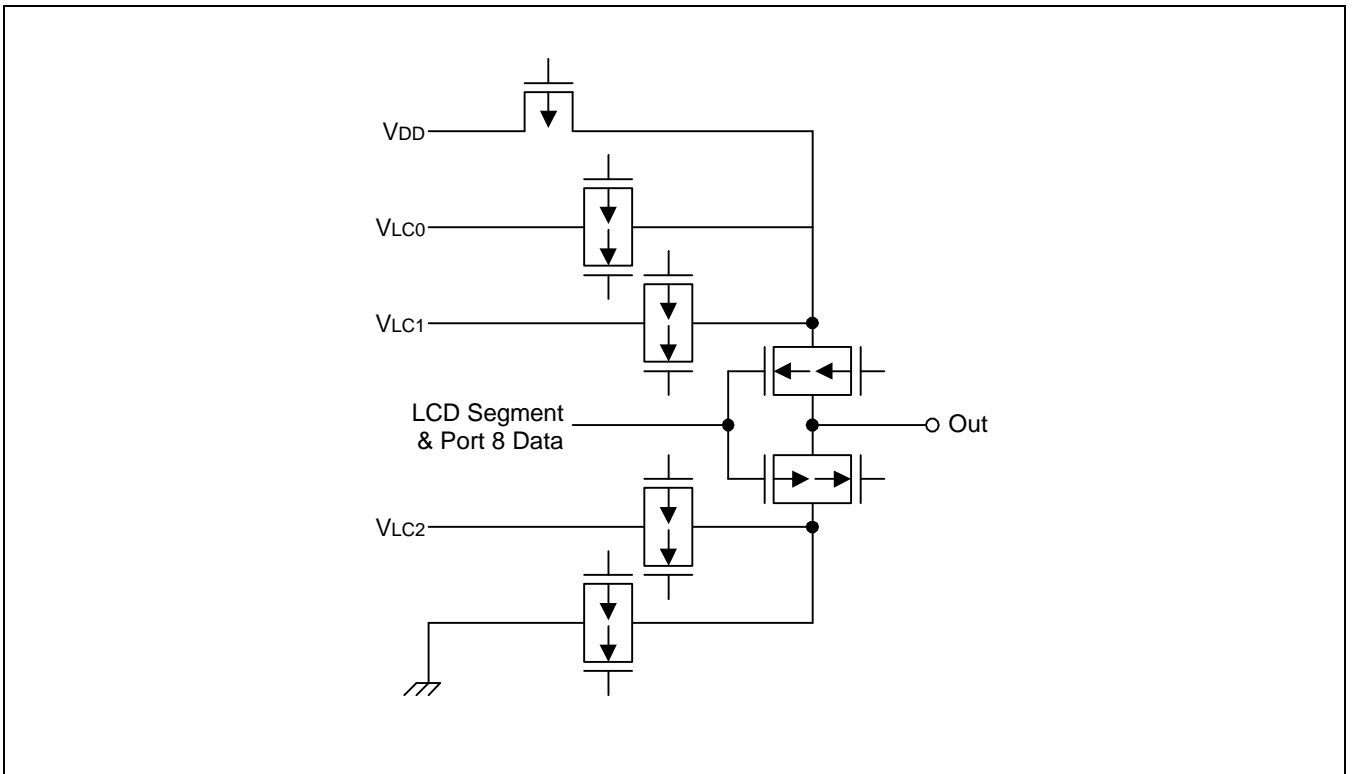

Figure 1-10. Pin Circuit Type H-16 (P8)

## NOTES

# 14 ELECTRICAL DATA

## OVERVIEW

In this section, information on S3C72N8/C72N5 electrical characteristics is presented as tables and graphics. The information is arranged in the following order:

### Standard Electrical Characteristics

- Absolute maximum ratings
- D.C. electrical characteristics
- Main system clock oscillator characteristics
- Subsystem clock oscillator characteristics
- I/O capacitance
- A.C. electrical characteristics
- Operating voltage range

### Miscellaneous Timing Waveforms

- A.C timing measurement point
- Clock timing measurement at  $X_{IN}$
- Clock timing measurement at  $XT_{IN}$
- TCL timing
- Input timing for RESET
- Input timing for external interrupts
- Serial data transfer timing

### Stop Mode Characteristics and Timing Waveforms

- RAM data retention supply voltage in stop mode
- Stop mode release timing when initiated by RESET
- Stop mode release timing when initiated by an interrupt request

Table 14-1. Absolute Maximum Ratings

(T<sub>A</sub> = 25 °C)

Parameter	Symbol	Conditions	Rating	Units
Supply Voltage	V <sub>DD</sub>	–	– 0.3 to + 6.5	V
Input Voltage	V <sub>I</sub>	All I/O ports	– 0.3 to V <sub>DD</sub> + 0.3	
Output Voltage	V <sub>O</sub>	–	– 0.3 to V <sub>DD</sub> + 0.3	
Output Current High	I <sub>OH</sub>	One I/O pin active	– 15	mA
		All I/O ports active	– 35	
Output Current Low	I <sub>OL</sub>	One I/O pin active	+ 30 (Peak value)	
			+ 15 (note)	
		Total value for ports 0, 2, 3, and 5	+ 100 (Peak value)	
			+ 60 (note)	
Total value for ports 4, 6, and 7	+ 100			
	+ 60 (note)			
Operating Temperature	T <sub>A</sub>	–	– 40 to + 85	°C
Storage Temperature	T <sub>stg</sub>	–	– 65 to + 150	

**NOTE:** The values for Output Current Low (I<sub>OL</sub>) are calculated as Peak Value × √Duty .

Table 14-2. D.C. Electrical Characteristics

(T<sub>A</sub> = – 40 °C to + 85 °C, V<sub>DD</sub> = 1.8 V to 5.5 V)

Parameter	Symbol	Conditions	Min	Typ	Max	Units
Input high voltage	V <sub>IH1</sub>	All input pins except those specified below for V <sub>IH2</sub> , V <sub>IH3</sub>	0.7 V <sub>DD</sub>	–	V <sub>DD</sub>	V
	V <sub>IH2</sub>	Ports 0, 1, 6, 7 and RESET	0.8 V <sub>DD</sub>	–	V <sub>DD</sub>	
	V <sub>IH3</sub>	X <sub>IN</sub> , X <sub>OUT</sub> , XT <sub>IN</sub> and XT <sub>OUT</sub>	V <sub>DD</sub> – 0.1	–	V <sub>DD</sub>	
Input low voltage	V <sub>IL1</sub>	Ports 2, 3, 4 and 5	–	–	0.3 V <sub>DD</sub>	V
	V <sub>IL2</sub>	Ports 0, 1, 6, 7 and RESET	–	–	0.2 V <sub>DD</sub>	
	V <sub>IL3</sub>	X <sub>IN</sub> , X <sub>OUT</sub> , XT <sub>IN</sub> and XT <sub>OUT</sub>	–	–	0.1	
Output high voltage	V <sub>OH1</sub>	V <sub>DD</sub> = 4.5 V to 5.5 V Ports 0, 2, 3, 4, 5, 6, 7 and BIAS I <sub>OH</sub> = – 1 mA	V <sub>DD</sub> – 1.0	–	–	V
	V <sub>OH2</sub>	V <sub>DD</sub> = 4.5 V to 5.5 V Port 8 ONLY I <sub>OH</sub> = – 100 μA	V <sub>DD</sub> – 2.0	–	–	

Table 14-2. D.C. Electrical Characteristics (Continued)

(T<sub>A</sub> = -40 °C to +85 °C, V<sub>DD</sub> = 1.8 V to 5.5 V)

Parameter	Symbol	Conditions	Min	Typ	Max	Units
Output low voltage	V <sub>OL1</sub>	V <sub>DD</sub> = 4.5 V to 5.5 V, Ports 0, 2-7 I <sub>OL</sub> = 15 mA	-	0.4	2	V
	V <sub>OL2</sub>	V <sub>DD</sub> = 4.5 V to 5.5 V, Port 8 only I <sub>OL</sub> = 100 μA	-	-	1	
Input high leakage current	I <sub>LIH1</sub>	V <sub>IN</sub> = V <sub>DD</sub> All input pins except those specified below for I <sub>LIH2</sub>	-	-	3	μA
	I <sub>LIH2</sub>	V <sub>IN</sub> = V <sub>DD</sub> X <sub>IN</sub> , X <sub>OUT</sub> , XT <sub>IN</sub> and XT <sub>OUT</sub>	-	-	20	
Input low leakage current	I <sub>LIL1</sub>	V <sub>IN</sub> = 0 V All input pins except X <sub>IN</sub> , X <sub>OUT</sub> , XT <sub>IN</sub> and XT <sub>OUT</sub>	-	-	-3	
	I <sub>LIL2</sub>	V <sub>IN</sub> = 0 V X <sub>IN</sub> , X <sub>OUT</sub> , XT <sub>IN</sub> and XT <sub>OUT</sub>	-	-	-20	
Output high leakage current	I <sub>LOH1</sub>	V <sub>OUT</sub> = V <sub>DD</sub> All output pins	-	-	3	μA
Output low leakage current	I <sub>LOL</sub>	V <sub>OUT</sub> = 0 V All output pins	-	-	-3	
Pull-up resistor	R <sub>L1</sub>	Ports 0-7 V <sub>IN</sub> = 0 V; V <sub>DD</sub> = 5 V	25	47	100	KΩ
		V <sub>DD</sub> = 3 V	50	95	200	
	R <sub>L2</sub>	V <sub>IN</sub> = 0 V; V <sub>DD</sub> = 5 V, RESET	100	220	400	
		V <sub>DD</sub> = 3 V	200	450	800	
LCD voltage dividing resistor	R <sub>LCD</sub>	T <sub>A</sub> = 25 °C	50	93	140	
COM output impedance	R <sub>COM</sub>	V <sub>DD</sub> = 5 V	-	3	6	
		V <sub>DD</sub> = 3 V		5	15	
SEG output impedance	R <sub>SEG</sub>	V <sub>DD</sub> = 5 V	-	3	6	
		V <sub>DD</sub> = 3 V		5	15	
COM output voltage deviation	V <sub>DC</sub>	V <sub>DD</sub> = 5 V (V <sub>LCO</sub> - COMi) I <sub>o</sub> = ±15μA (I = 0-3)	-	±45	±90	mV
SEG output voltage deviation	V <sub>DS</sub>	V <sub>DD</sub> = 5 V (V <sub>LCO</sub> -SEGi) I <sub>o</sub> = ±15μA (I = 0-31)	-	±45	±90	mV

Table 14-2. D.C. Electrical Characteristics (Concluded)

(T<sub>A</sub> = -40 °C to +85 °C, V<sub>DD</sub> = 1.8 V to 5.5 V)

Parameter	Symbol	Conditions		Min	Typ	Max	Units
V <sub>LC0</sub> Output voltage	V <sub>LC0</sub>	T <sub>A</sub> = 25 °C		0.6 V <sub>DD</sub> - 0.2	0.6 V <sub>DD</sub>	0.6 V <sub>DD</sub> + 0.2	V
V <sub>LC1</sub> Output voltage	V <sub>LC1</sub>	T <sub>A</sub> = 25 °C		0.4 V <sub>DD</sub> - 0.2	0.4 V <sub>DD</sub>	0.4 V <sub>DD</sub> + 0.2	
V <sub>LC2</sub> Output voltage	V <sub>LC2</sub>	T <sub>A</sub> = 25 °C		0.2 V <sub>DD</sub> - 0.2	0.2 V <sub>DD</sub>	0.2 V <sub>DD</sub> + 0.2	
Supply Current (1)	I <sub>DD1</sub> (2)	Main operating: V <sub>DD</sub> = 5 V ± 10% CPU = fx/4 SCMOD = 0000B crystal oscillator C1 = C2 = 22pF	6.0 MHz 4.19 MHz	-	3.5 2.5	8 5.5	mA
		V <sub>DD</sub> = 3 V ± 10%	6.0 MHz 4.19 MHz		1.6 1.2	4 3	
	I <sub>DD2</sub> (2)	Main Idle mode; V <sub>DD</sub> = 5 V ± 10% CPU = fx/4 SCMOD = 0000B crystal oscillator C1 = C2 = 22pF	6.0 MHz 4.19 MHz	-	1.0 0.9	2.5 2.0	
		V <sub>DD</sub> = 3 V ± 10%	6.0 MHz 4.19 MHz		0.5 0.4	1.0 0.8	
	I <sub>DD3</sub>	Sub operating: V <sub>DD</sub> = 3 V ± 10% CPU = fxt/4 SCMOD = 1001B 32 kHz crystal oscillator		-	15	30	μA
	I <sub>DD4</sub>	Sub Idle mode; V <sub>DD</sub> = 3 V ± 10% CPU = fxt/4, SCMOD = 1001B 32 kHz crystal oscillator		-	6	15	
	I <sub>DD5</sub>	Stop mode; V <sub>DD</sub> = 5 V ± 10%, XT <sub>IN</sub> = 0 V CPU = fxt/4, SCMOD = 0000B		-	2.5	5	
	I <sub>DD6</sub> (3)	Stop mode; V <sub>DD</sub> = 5 V ± 10% CPU = fx/4, SCMOD = 0100B		-	0.5	3	

**NOTES:**

1. D.C. electrical values for supply current (I<sub>DD1</sub> to I<sub>DD6</sub>) do not include current drawn through internal pull-up resistors and through LCD voltage dividing resistors.
2. Data includes the power consumption for sub-system clock oscillation.
3. When the system clock mode register, SCMOD, is set to 0100B, the sub-system clock oscillation stops. The main-system clock oscillation stops by the STOP instruction.

Table 14-3. Main System Clock Oscillator Characteristics

(T<sub>A</sub> = -40 °C + 85 °C, V<sub>DD</sub> = 1.8 V to 5.5 V)

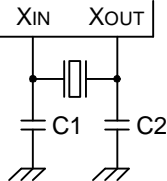
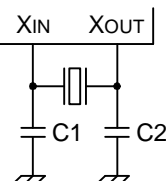
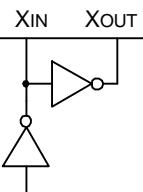
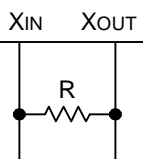
Oscillator	Clock Configuration	Parameter	Test Condition	Min	Typ	Max	Units
Ceramic Oscillator		Oscillation frequency <sup>(1)</sup>	–	0.4	–	6.0	MHz
		Stabilization time <sup>(2)</sup>	Stabilization occurs when V <sub>DD</sub> is equal to the minimum oscillator voltage range.	–	–	4	ms
Crystal Oscillator		Oscillation frequency <sup>(1)</sup>	–	0.4	–	6.0	MHz
		Stabilization time <sup>(2)</sup>	V <sub>DD</sub> = 4.5 V to 5.5 V	–	–	10	ms
			V <sub>DD</sub> = 1.8 V to 4.5 V	–	–	30	
External Clock		X <sub>IN</sub> input frequency <sup>(1)</sup>	–	0.4	–	6.0	MHz
		X <sub>IN</sub> input high and low level width (t <sub>XH</sub> , t <sub>XL</sub> )	–	83.3	–	–	ns
RC Oscillator		Frequency <sup>(1)</sup>	V <sub>DD</sub> = 5 V R = 20 KΩ, V <sub>DD</sub> = 5 V R = 38 KΩ, V <sub>DD</sub> = 3 V	0.4	– 2.0 1.0	2	MHz

**NOTES:**

- Oscillation frequency and X<sub>IN</sub> input frequency data are for oscillator characteristics only.
- Stabilization time is the interval required for oscillator stabilization after a power-on occurs, or when stop mode is terminated.

Table 14-4. Subsystem Clock Oscillator Characteristics

(T<sub>A</sub> = -40 °C + 85 °C, V<sub>DD</sub> = 1.8 V to 5.5 V)

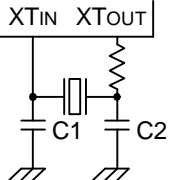
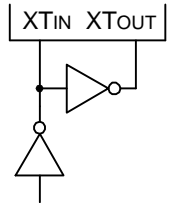
Oscillator	Clock Configuration	Parameter	Test Condition	Min	Typ	Max	Units
Crystal Oscillator		Oscillation frequency <sup>(1)</sup>	–	32	32.768	35	kHz
		Stabilization time <sup>(2)</sup>	V <sub>DD</sub> = 4.5 V to 5.5 V	–	1.0	2	s
			V <sub>DD</sub> = 1.8 V to 4.5 V	–	–	10	
External Clock		XT <sub>IN</sub> input frequency <sup>(1)</sup>	–	32	–	100	kHz
		XT <sub>IN</sub> input high and low level width (t <sub>XTL</sub> , t <sub>XTH</sub> )	–	5	–	15	μs

**NOTES:**

- Oscillation frequency and XT<sub>IN</sub> input frequency data are for oscillator characteristics only.
- Stabilization time is the interval required for oscillating stabilization after a power-on occurs.

Table 14-5. Input/Output Capacitance

(T<sub>A</sub> = 25 °C, V<sub>DD</sub> = 0 V)

Parameter	Symbol	Condition	Min	Typ	Max	Units
Input capacitance	C <sub>IN</sub>	f = 1 MHz; Unmeasured pins are returned to V <sub>SS</sub>	–	–	15	pF
Output capacitance	C <sub>OUT</sub>		–	–	15	pF
I/O capacitance	C <sub>IO</sub>		–	–	15	pF



Table 14-6. A.C. Electrical Characteristics

(T<sub>A</sub> = -40 °C to +85 °C, V<sub>DD</sub> = 1.8 V to 5.5 V)

Parameter	Symbol	Conditions	Min	Typ	Max	Units
Instruction cycle time (1)	t <sub>CY</sub>	V <sub>DD</sub> = 2.7 V to 5.5 V	0.67	–	64	μs
		V <sub>DD</sub> = 1.8 V to 5.5 V	0.95	–	64	
		With subsystem clock (fxt)	114	122	125	
TCL0 input frequency	f <sub>TIO</sub>	V <sub>DD</sub> = 2.7 V to 5.5 V	0	–	1.5	MHz
		V <sub>DD</sub> = 1.8 V to 5.5 V			1	MHz
TCL0 input high, low width	t <sub>TIH0</sub> , t <sub>TILO</sub>	V <sub>DD</sub> = 2.7 V to 5.5 V	0.48	–	–	μs
		V <sub>DD</sub> = 1.8 V to 5.5 V	1.8			
SCK cycle time	t <sub>KCY</sub>	V <sub>DD</sub> = 2.7 V to 5.5 V External SCK source	800	–	–	ns
		Internal SCK source	650			
		V <sub>DD</sub> = 1.8 V to 5.5 V External SCK source	3200			
		Internal SCK source	3800			
SCK high, low width	t <sub>KH</sub> , t <sub>KL</sub>	V <sub>DD</sub> = 1.8 V to 5.5 V External SCK source	400	–	–	ns
		Internal SCK source	t <sub>KCY</sub> /2 – 50			
		V <sub>DD</sub> = 1.8 V to 5.5 V External SCK source	1600			
		Internal SCK source	t <sub>KCY</sub> /2 – 150			
SI setup time to SCK high	t <sub>SIK</sub>	External SCK source	100	–	–	ns
		Internal SCK source	150			
SI hold time to SCK high	t <sub>KSI</sub>	External SCK source	400	–	–	ns
		Internal SCK source	400			
Output delay for SCK to SO	t <sub>KSO</sub>	V <sub>DD</sub> = 2.7 V to 5.5 V External SCK source	–	–	300	ns
		Internal SCK source			250	
		V <sub>DD</sub> = 1.8 V to 5.5 V External SCK source			1000	
		Internal SCK source			1000	
Interrupt input high, low width	t <sub>INTH</sub> , t <sub>INTL</sub>	INT0	(2)	–	–	μs
		INT1, INT2, INT4, KS0–KS7	10			
RESET Input Low Width	t <sub>RSL</sub>	Input	10	–	–	μs

**NOTES:**

- Unless otherwise specified, Instruction Cycle Time condition values assume a main system clock (fx) source.
- Minimum value for INT0 is based on a clock of 2t<sub>CY</sub> or 128/fx as assigned by the IMOD0 register setting.

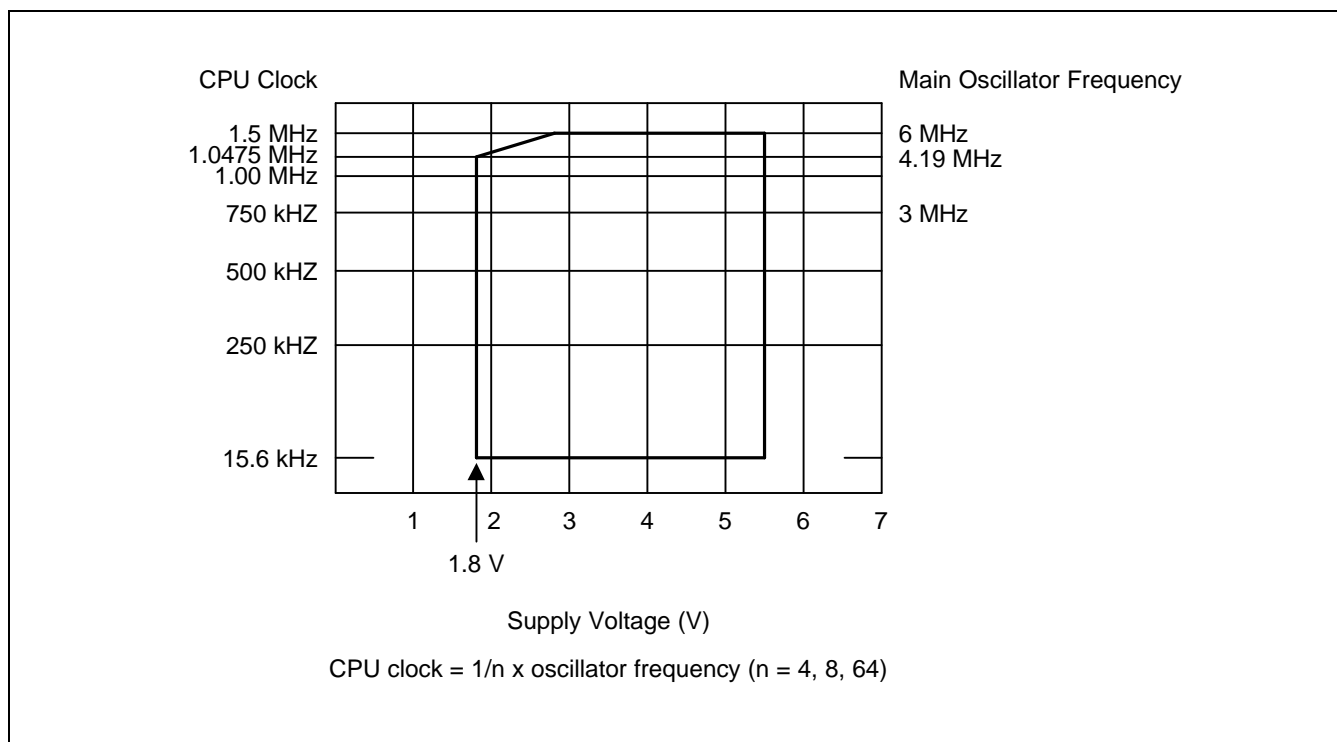

Figure 14-1. Standard Operating Voltage Range

Table 14-7. RAM Data Retention Supply Voltage in Stop Mode

(T<sub>A</sub> = -40 °C to +85 °C)

Parameter	Symbol	Conditions	Min	Typ	Max	Unit
Data retention supply voltage	V <sub>DDDR</sub>	Normal operation	1.8	–	6.5	V
Data retention supply current	I <sub>DDDR</sub>	V <sub>DDDR</sub> = 1.8 V	–	0.1	10	μA
Release signal set time	t <sub>SREL</sub>	Normal operation	0	–	–	μs
Oscillator stabilization wait time (1)	t <sub>WAIT</sub>	Released by RESET	–	2 <sup>17</sup> /f <sub>x</sub>	–	ms
		Released by interrupt	–	(2)	–	

**NOTES:**

1. During oscillator stabilization wait time, all CPU operations must be stopped to avoid instability during oscillator start-up.
2. Use the basic timer mode register (BMOD) interval timer to delay execution of CPU instructions during the wait time.

TIMING WAVEFORMS

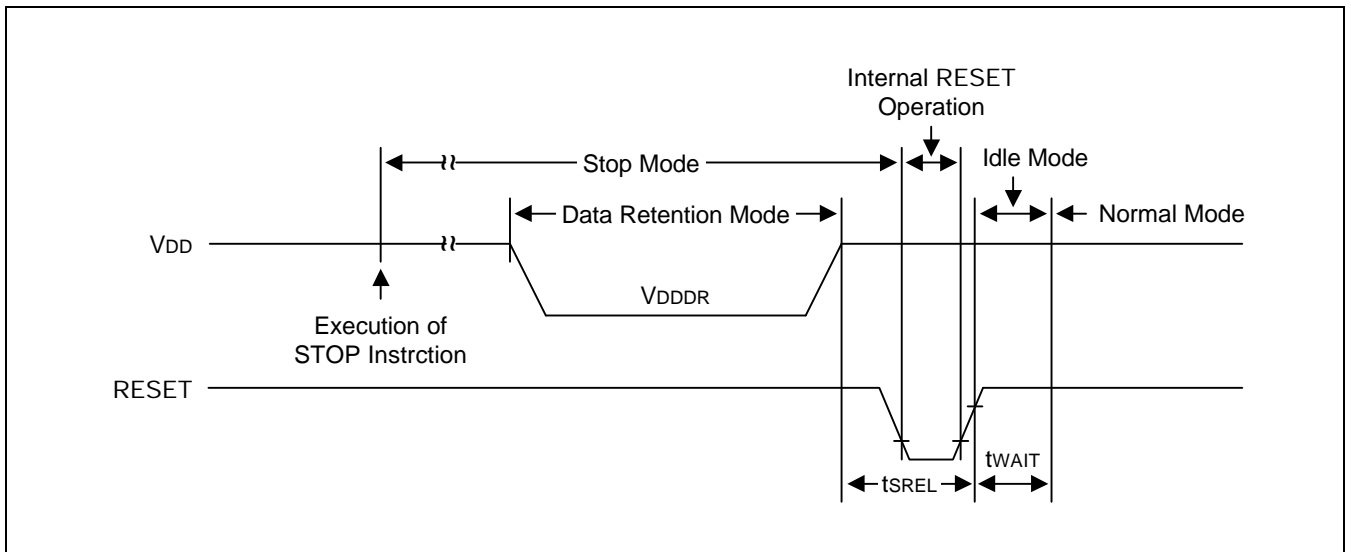

Figure 14-2. Stop Mode Release Timing When Initiated By RESET

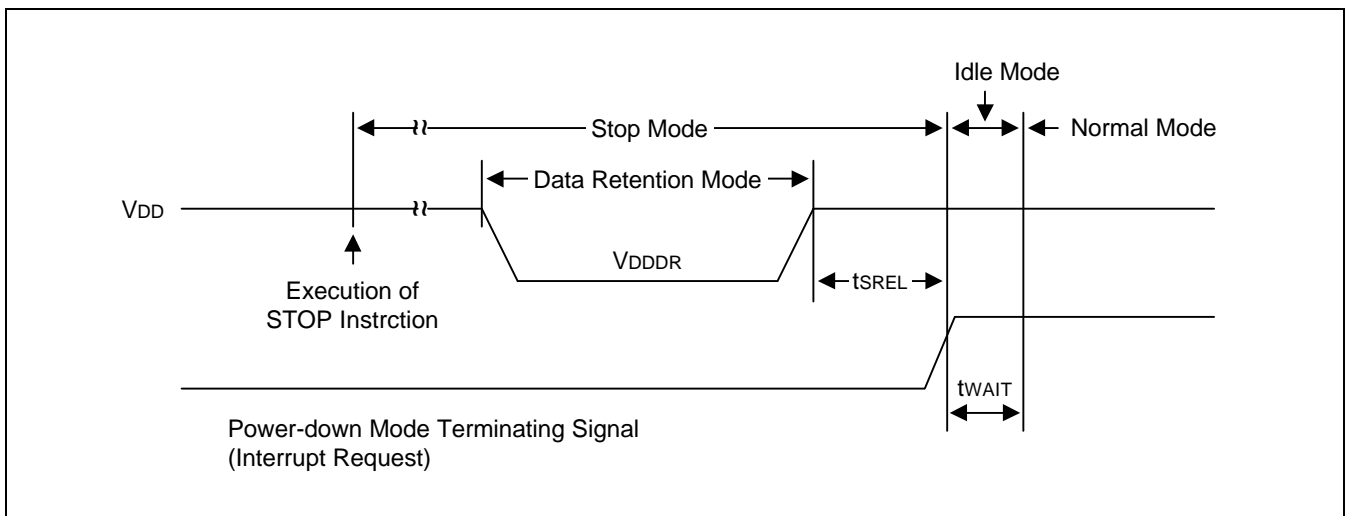

Figure 14-3. Stop Mode Release Timing When Initiated By Interrupt Request

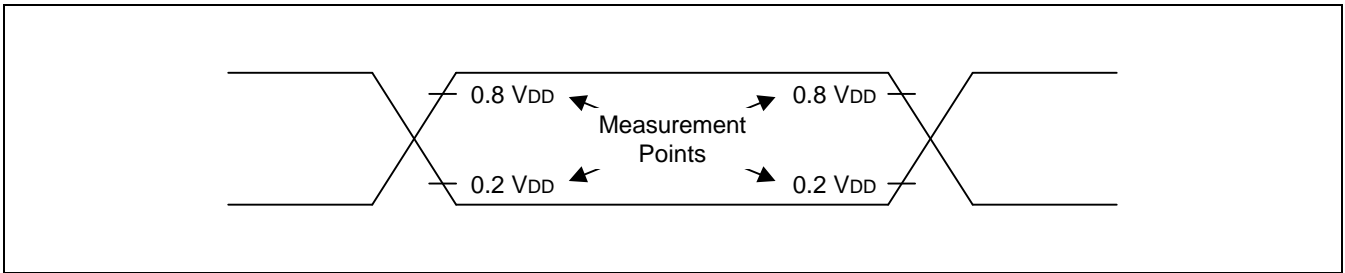

Figure 14-4. A.C. Timing Measurement Points (Except for  $X_{IN}$  and  $XT_{IN}$ )

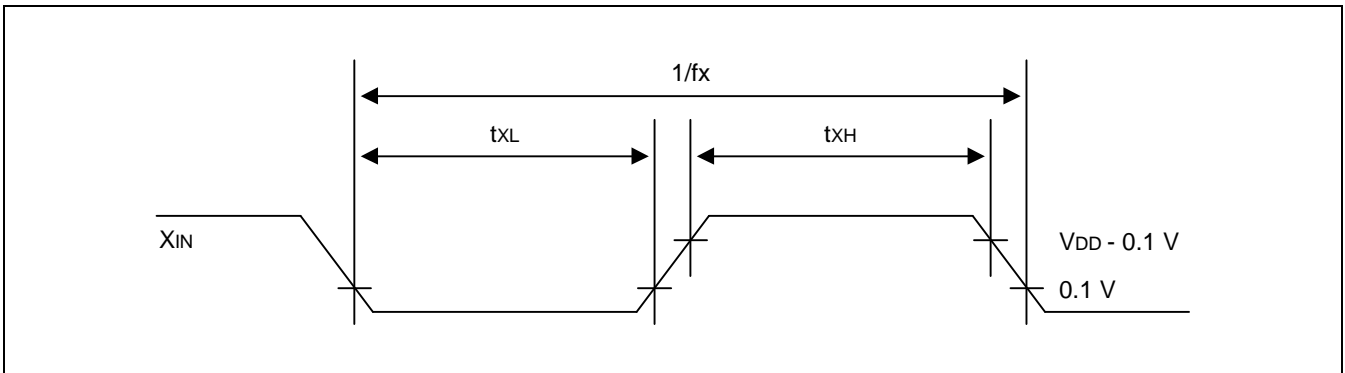

Figure 14-5. Clock Timing Measurement at  $X_{IN}$

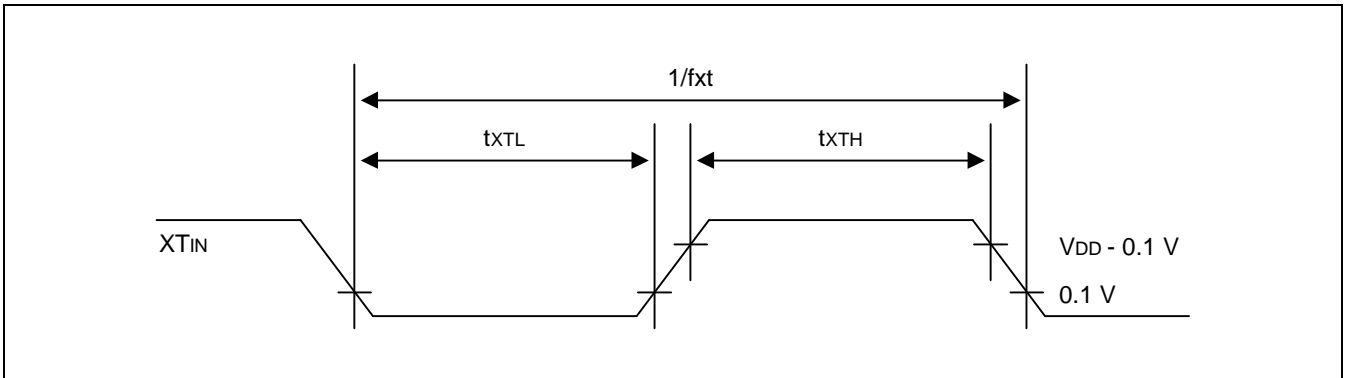

Figure 14-6. Clock Timing Measurement at  $XT_{IN}$

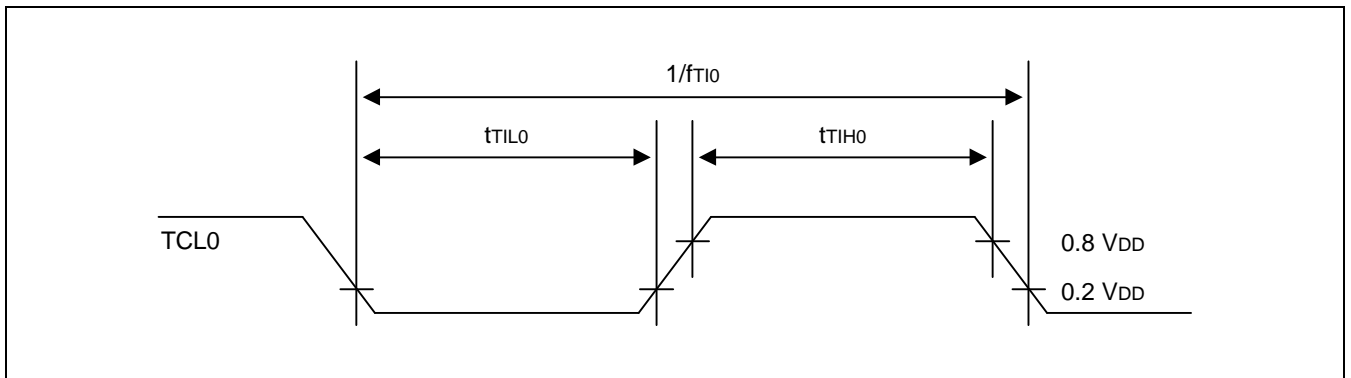

Figure 14-7. TCL0 Timing

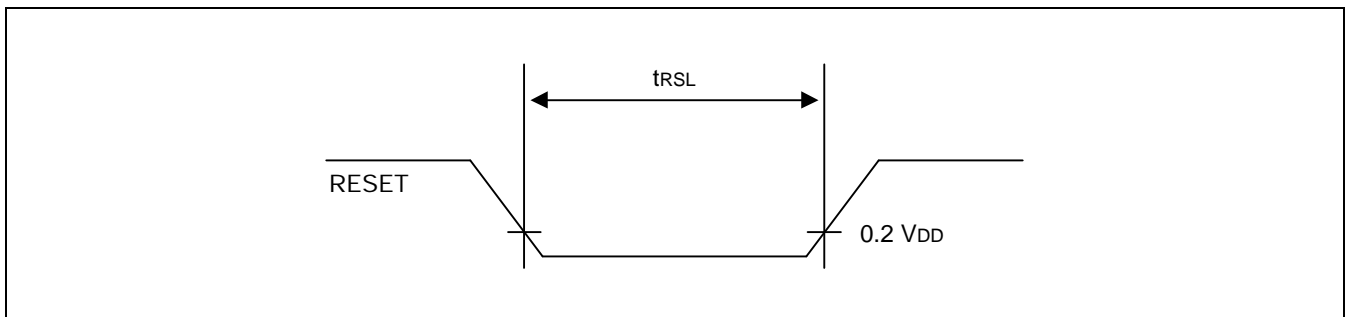

Figure 14-8. Input Timing for RESET Signal

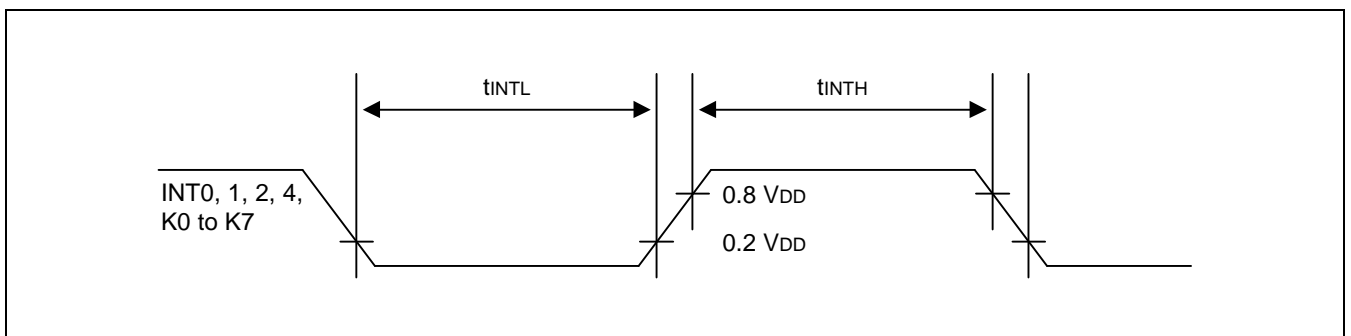

Figure 14-9. Input Timing for External Interrupts and Quasi-Interrupts

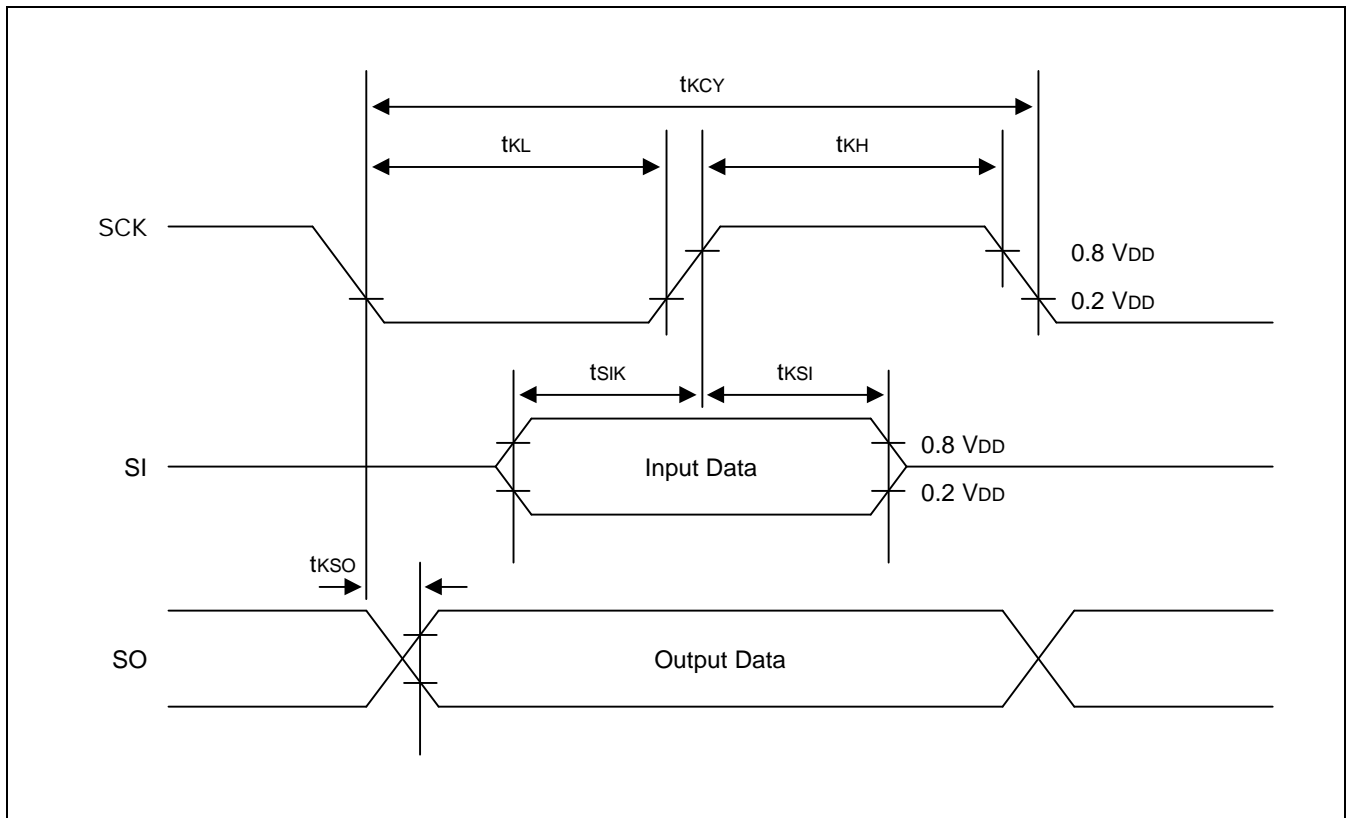

Figure 14-10. Serial Data Transfer Timing

# 15

## MECHANICAL DATA

### OVERVIEW

This section contains the following information about the device package:

- Package dimensions in millimeters
- Pad diagram
- Pad/pin coordinate data table

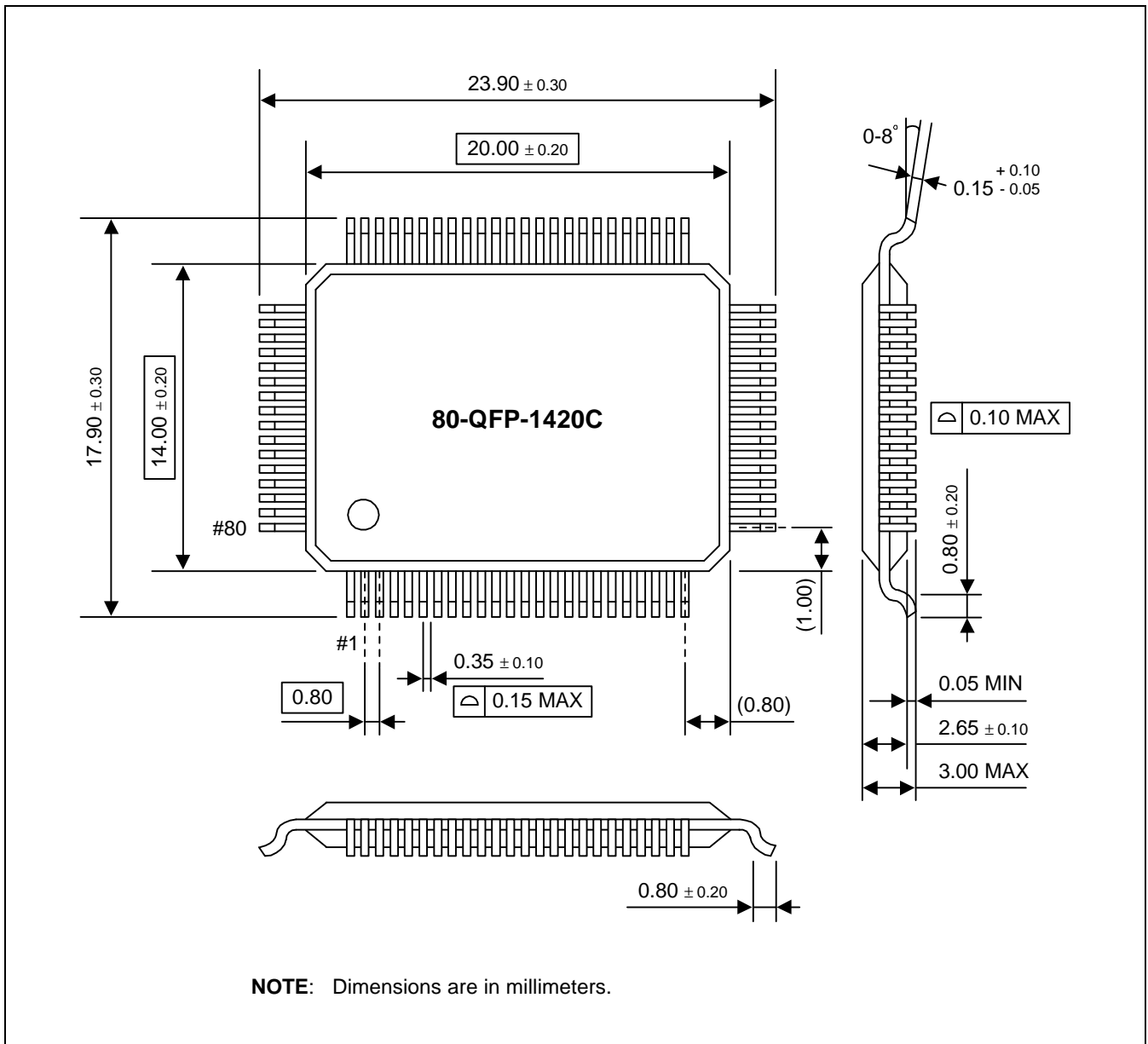

Figure 15-1. 80-QFP-1420C Package Dimensions



# 16

## S3P72N8/P72N5 OTP

### OVERVIEW

The S3P72N8/P72N5 single-chip CMOS microcontroller is the OTP (One Time Programmable) version of the S3C72N8/C72N5 microcontroller. It has an on-chip EPROM instead of masked ROM. The EPROM is accessed by a serial data format.

The S3P72N8/P72N5 is fully compatible with the S3C72N8/C72N5, both in function and in pin configuration. Because of its simple programming requirements, the S3P72N8/P72N5 is ideal for use as an evaluation chip for the S3C72N8/C72N5.

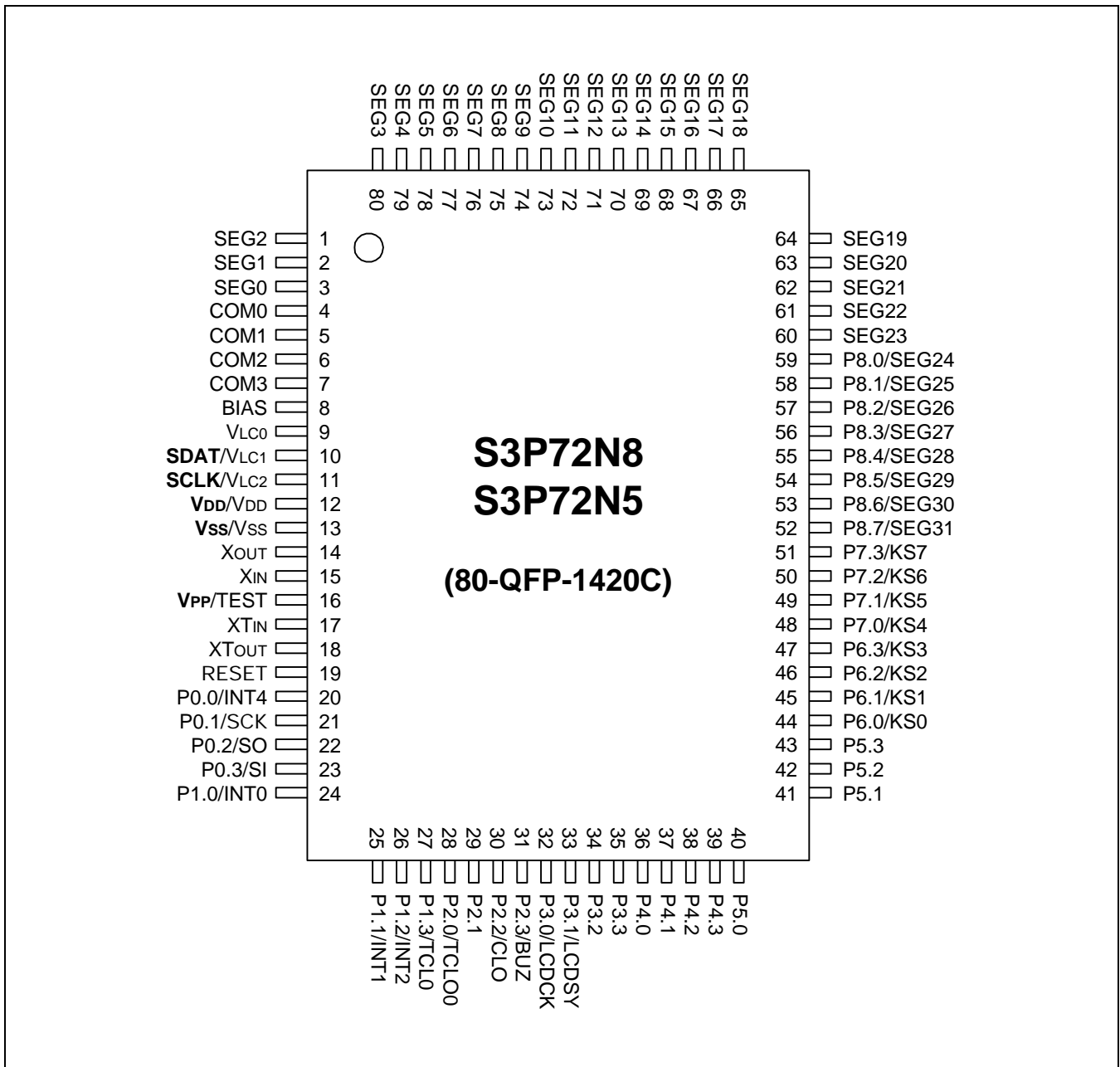

Figure 16-1. S3P72N8/P72N5 Pin Assignments (80-QFP)

Table 16-1. Pin Descriptions Used to Read/Write the EPROM

Main Chip	During Programming			
Pin Name	Pin Name	Pin No.	I/O	Function
$V_{LC1}$	SDAT	10	I/O	Serial data pin. Output port when reading and input port when writing can be assigned as Input/push-pull output port respectively.
$V_{LC2}$	SCLK	11	I/O	Serial clock pin. Input only pin.
TEST	$V_{PP}$ (TEST)	16	I	Power supply pin for EPROM cell writing (indicates that OTP enters into the writing mode). When 12.5 V is applied, OTP is in writing mode and when 5 V is applied, OTP is in reading mode. (Option)
RESET	RESET	19	I	Chip initialization
$V_{DD}/V_{SS}$	$V_{DD}/V_{SS}$	12/13	I	Logic power supply pin. $V_{DD}$ should be tied to +5 V during programming.

Table 16-2. Comparison of S3P72N8/P72N5 and S3C72N8/C72N5 Features

Characteristic	S3P72N8/P72N5	S3C72N8/C72N5
Program Memory	8 K/16 K-byte EPROM	8 K/16-Kbyte mask ROM
Operating Voltage ( $V_{DD}$ )	1.8 V to 5.5 V	1.8 V to 5.5 V
OTP Programming Mode	$V_{DD} = 5$ V, $V_{PP}$ (TEST) = 12.5 V	–
Pin Configuration	80 QFP	80 QFP
EPROM Programmability	User Program 1 time	Programmed at the factory

## OPERATING MODE CHARACTERISTICS

When 12.5 V is supplied to the  $V_{PP}$  (TEST) pin of the S3P72N8/P72N5, the EPROM programming mode is entered. The operating mode (read, write, or read protection) is selected according to the input signals to the pins listed in Table 16-3 below.

Table 16-3. Operating Mode Selection Criteria

$V_{DD}$	$V_{PP}$ (TEST)	REG/MEM	Address (A15-A0)	R/W	Mode
5 V	5 V	0	0000H	1	EPROM read
	12.5V	0	0000H	0	EPROM program
	12.5V	0	0000H	1	EPROM verify
	12.5V	1	0E3FH	0	EPROM read protection

**NOTE:** "0" means low level; "1" means high level.

Table 16-4. Absolute Maximum Ratings

(T<sub>A</sub> = 25 °C)

Parameter	Symbol	Conditions	Rating	Units
Supply Voltage	V <sub>DD</sub>	–	– 0.3 to + 6.5	V
Input Voltage	V <sub>I1</sub>	All I/O ports	– 0.3 to V <sub>DD</sub> + 0.3	
Output Voltage	V <sub>O</sub>	–	– 0.3 to V <sub>DD</sub> + 0.3	
Output Current High	I <sub>OH</sub>	One I/O pin active	– 15	mA
		All I/O ports active	– 35	
Output Current Low	I <sub>OL</sub>	One I/O pin active	+ 30 (Peak value)	
			+ 15 (note)	
		Total value for ports 0, 2, 3, and 5	+ 100 (Peak value)	
			+ 60 (note)	
Total value for ports 4, 6, and 7	+ 100			
	+ 60 (note)			
Operating Temperature	T <sub>A</sub>	–	– 40 to + 85	°C
Storage Temperature	T <sub>stg</sub>	–	– 65 to + 150	

**NOTE:** The values for Output Current Low (I<sub>OL</sub>) are calculated as Peak Value × √Duty .

Table 16-5. D.C. Electrical Characteristics

(T<sub>A</sub> = – 40 °C to + 85 °C, V<sub>DD</sub> = 1.8 V to 5.5 V)

Parameter	Symbol	Conditions	Min	Typ	Max	Units
Input high voltage	V <sub>IH1</sub>	All input pins except those specified below for V <sub>IH2</sub> , V <sub>IH3</sub>	0.7 V <sub>DD</sub>	–	V <sub>DD</sub>	V
	V <sub>IH2</sub>	Ports 0, 1, 6, 7 and RESET	0.8 V <sub>DD</sub>	–	V <sub>DD</sub>	
	V <sub>IH3</sub>	X <sub>IN</sub> , X <sub>OUT</sub> , XT <sub>IN</sub> and XT <sub>OUT</sub>	V <sub>DD</sub> – 0.1	–	V <sub>DD</sub>	
Input low voltage	V <sub>IL1</sub>	Ports 2, 3, 4 and 5	–	–	0.3 V <sub>DD</sub>	V
	V <sub>IL2</sub>	Ports 0, 1, 6, 7 and RESET	–	–	0.2 V <sub>DD</sub>	
	V <sub>IL3</sub>	X <sub>IN</sub> , X <sub>OUT</sub> , XT <sub>IN</sub> and XT <sub>OUT</sub>	–	–	0.1	
Output high voltage	V <sub>OH1</sub>	V <sub>DD</sub> = 4.5 V to 5.5 V Ports 0, 2, 3, 4, 5, 6, 7 and BIAS I <sub>OH</sub> = – 1 mA	V <sub>DD</sub> – 1.0	–	–	V
	V <sub>OH2</sub>	V <sub>DD</sub> = 4.5 V to 5.5 V Port 8 ONLY I <sub>OH</sub> = – 100 μA	V <sub>DD</sub> – 2.0	–	–	

Table 16-5. D.C. Electrical Characteristics (Continued)

(T<sub>A</sub> = -40 °C to +85 °C, V<sub>DD</sub> = 1.8 V to 5.5 V)

Parameter	Symbol	Conditions	Min	Typ	Max	Units
Output low voltage	V <sub>OL1</sub>	V <sub>DD</sub> = 4.5 V to 5.5 V, Ports 0, 2-7 I <sub>OL</sub> = 15 mA	-	0.4	2	V
	V <sub>OL2</sub>	V <sub>DD</sub> = 4.5 V to 5.5 V, Port 8 only I <sub>OL</sub> = 100 μA	-	-	1	
Input high leakage current	I <sub>LH1</sub>	V <sub>IN</sub> = V <sub>DD</sub> All input pins except those specified below for I <sub>LH2</sub>	-	-	3	μA
	I <sub>LH2</sub>	V <sub>IN</sub> = V <sub>DD</sub> X <sub>IN</sub> , X <sub>OUT</sub> , XT <sub>IN</sub> and XT <sub>OUT</sub>	-	-	20	
Input low leakage current	I <sub>LIL1</sub>	V <sub>IN</sub> = 0 V All input pins except X <sub>IN</sub> , X <sub>OUT</sub> , XT <sub>IN</sub> and XT <sub>OUT</sub>	-	-	-3	
	I <sub>LIL2</sub>	V <sub>IN</sub> = 0 V X <sub>IN</sub> , X <sub>OUT</sub> , XT <sub>IN</sub> and XT <sub>OUT</sub>	-	-	-20	
Output high leakage current	I <sub>LOH1</sub>	V <sub>OUT</sub> = V <sub>DD</sub> All output pins	-	-	3	μA
Output low leakage current	I <sub>LOL</sub>	V <sub>OUT</sub> = 0 V All output pins	-	-	-3	
Pull-up resistor	R <sub>L1</sub>	Ports 0-7 V <sub>IN</sub> = 0 V; V <sub>DD</sub> = 5 V	25	47	100	KΩ
		V <sub>DD</sub> = 3 V	50	95	200	
	R <sub>L2</sub>	V <sub>IN</sub> = 0 V; V <sub>DD</sub> = 5 V, RESET	100	220	400	
		V <sub>DD</sub> = 3 V	200	450	800	
LCD voltage dividing resistor	R <sub>LCD</sub>	T <sub>A</sub> = 25 °C	50	93	140	
COM output impedance	R <sub>COM</sub>	V <sub>DD</sub> = 5 V	-	3	6	
		V <sub>DD</sub> = 3 V		5	15	
SEG output impedance	R <sub>SEG</sub>	V <sub>DD</sub> = 5 V		3	6	
		V <sub>DD</sub> = 3 V		5	15	
COM output voltage deviation	V <sub>DC</sub>	V <sub>DD</sub> = 5 V (V <sub>LC0</sub> -COMi) I <sub>o</sub> = ±15μA (I = 0-3)	-	±45	±90	mV
SEG output voltage deviation	V <sub>DS</sub>	V <sub>DD</sub> = 5 V (V <sub>LC0</sub> -SEGi) I <sub>o</sub> = ±15μA (I = 0-31)	-	±45	±90	mV

Table 16-5. D.C. Electrical Characteristics (Concluded)

(T<sub>A</sub> = -40 °C to +85 °C, V<sub>DD</sub> = 1.8 V to 5.5 V)

Parameter	Symbol	Conditions		Min	Typ	Max	Units
V <sub>LC0</sub> Output voltage	V <sub>LC0</sub>	T <sub>A</sub> = 25 °C		0.6 V <sub>DD</sub> - 0.2	0.6 V <sub>DD</sub>	0.6 V <sub>DD</sub> + 0.2	V
V <sub>LC1</sub> Output voltage	V <sub>LC1</sub>	T <sub>A</sub> = 25 °C		0.4 V <sub>DD</sub> - 0.2	0.4 V <sub>DD</sub>	0.4 V <sub>DD</sub> + 0.2	
V <sub>LC2</sub> Output voltage	V <sub>LC2</sub>	T <sub>A</sub> = 25 °C		0.2 V <sub>DD</sub> - 0.2	0.2 V <sub>DD</sub>	0.2 V <sub>DD</sub> + 0.2	
Supply Current (1)	I <sub>DD1</sub> (2)	Main operating: V <sub>DD</sub> = 5 V ± 10% CPU = fx/4 SCMOD = 0000B crystal oscillator C1 = C2 = 22pF	6.0 MHz 4.19 MHz	-	3.5 2.5	8 5.5	mA
		V <sub>DD</sub> = 3 V ± 10%	6.0 MHz 4.19 MHz		1.6 1.2	4 3	
	I <sub>DD2</sub> (2)	Main Idle mode; V <sub>DD</sub> = 5 V ± 10% CPU = fx/4 SCMOD = 0000B crystal oscillator C1 = C2 = 22pF	6.0 MHz 4.19 MHz	-	1.0 0.9	2.5 2.0	
		V <sub>DD</sub> = 3 V ± 10%	6.0 MHz 4.19 MHz		0.5 0.4	1.0 0.8	
	I <sub>DD3</sub>	Sub operating: V <sub>DD</sub> = 3 V ± 10% CPU = fxt/4 SCMOD = 1001B 32 kHz crystal oscillator		-	15	30	μA
	I <sub>DD4</sub>	Sub Idle mode; V <sub>DD</sub> = 3 V ± 10% CPU = fxt/4, SCMOD = 1001B 32 kHz crystal oscillator		-	6	15	
	I <sub>DD5</sub>	Stop mode; V <sub>DD</sub> = 5 V ± 10%, XT <sub>IN</sub> = 0 V CPU = fxt/4, SCMOD = 0000B		-	2.5	5	
	I <sub>DD6</sub> (3)	Stop mode; V <sub>DD</sub> = 5 V ± 10% CPU = fx/4, SCMOD = 0100B		-	0.5	3	

**NOTES:**

1. D.C. electrical values for supply current (I<sub>DD1</sub> to I<sub>DD6</sub>) do not include current drawn through internal pull-up resistors and through LCD voltage dividing resistors.
2. Data includes the power consumption for sub-system clock oscillation.
3. When the system clock mode register, SCMOD, is set to 0100B, the sub-system clock oscillation stops. The main-system clock oscillation stops by the STOP instruction.

Table 16-6. Main System Clock Oscillator Characteristics

(T<sub>A</sub> = -40 °C + 85 °C, V<sub>DD</sub> = 1.8 V to 5.5 V)

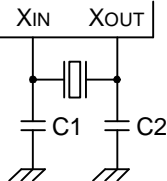
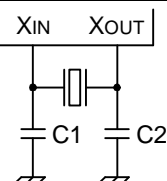
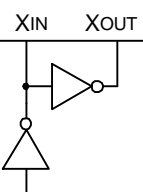
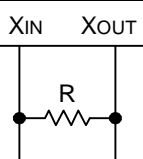
Oscillator	Clock Configuration	Parameter	Test Condition	Min	Typ	Max	Units
Ceramic Oscillator		Oscillation frequency <sup>(1)</sup>	–	0.4	–	6.0	MHz
		Stabilization time <sup>(2)</sup>	Stabilization occurs when V <sub>DD</sub> is equal to the minimum oscillator voltage range.	–	–	4	ms
Crystal Oscillator		Oscillation frequency <sup>(1)</sup>	–	0.4	–	6.0	MHz
		Stabilization time <sup>(2)</sup>	V <sub>DD</sub> = 4.5 V to 5.5 V	–	–	10	ms
			V <sub>DD</sub> = 1.8 V to 4.5 V	–	–	30	
External Clock		X <sub>IN</sub> input frequency <sup>(1)</sup>	–	0.4	–	6.0	MHz
		X <sub>IN</sub> input high and low level width (t <sub>XH</sub> , t <sub>XL</sub> )	–	83.3	–	–	ns
RC Oscillator		Frequency <sup>(1)</sup>	V <sub>DD</sub> = 5 V R = 20 KΩ, V <sub>DD</sub> = 5 V R = 38 KΩ, V <sub>DD</sub> = 3 V	0.4	– 2.0 1.0	2	MHz

**NOTES:**

- Oscillation frequency and X<sub>IN</sub> input frequency data are for oscillator characteristics only.
- Stabilization time is the interval required for oscillator stabilization after a power-on occurs, or when stop mode is terminated.

Table 16-7. Subsystem Clock Oscillator Characteristics

(T<sub>A</sub> = -40 °C + 85 °C, V<sub>DD</sub> = 1.8 V to 5.5 V)

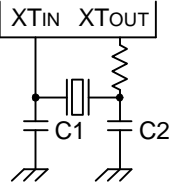
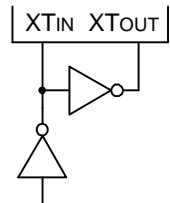
Oscillator	Clock Configuration	Parameter	Test Condition	Min	Typ	Max	Units
Crystal Oscillator		Oscillation frequency <sup>(1)</sup>	–	32	32.768	35	kHz
		Stabilization time <sup>(2)</sup>	V <sub>DD</sub> = 4.5 V to 5.5 V	–	1.0	2	s
			V <sub>DD</sub> = 1.8 V to 4.5 V	–	–	10	
External Clock		XT <sub>IN</sub> input frequency <sup>(1)</sup>	–	32	–	100	kHz
		XT <sub>IN</sub> input high and low level width (t <sub>XTL</sub> , t <sub>XTH</sub> )	–	5	–	15	μs

**NOTES:**

- Oscillation frequency and XT<sub>IN</sub> input frequency data are for oscillator characteristics only.
- Stabilization time is the interval required for oscillating stabilization after a power-on occurs.

Table 16-8. Input/Output Capacitance

(T<sub>A</sub> = 25 °C, V<sub>DD</sub> = 0 V)

Parameter	Symbol	Condition	Min	Typ	Max	Units
Input capacitance	C <sub>IN</sub>	f = 1 MHz; Unmeasured pins are returned to V <sub>SS</sub>	–	–	15	pF
Output capacitance	C <sub>OUT</sub>		–	–	15	pF
I/O capacitance	C <sub>IO</sub>		–	–	15	pF



Table 16-9. A.C. Electrical Characteristics

(T<sub>A</sub> = -40 °C to +85 °C, V<sub>DD</sub> = 1.8 V to 5.5 V)

Parameter	Symbol	Conditions	Min	Typ	Max	Units
Instruction cycle time (1)	t <sub>CY</sub>	V <sub>DD</sub> = 2.7 V to 5.5 V	0.67	–	64	μs
		V <sub>DD</sub> = 1.8 V to 5.5 V	0.95	–	64	
		With subsystem clock (fxt)	114	122	125	
TCL0 input frequency	f <sub>TIO</sub>	V <sub>DD</sub> = 2.7 V to 5.5 V	0	–	1.5	MHz
		V <sub>DD</sub> = 1.8 V to 5.5 V			1	MHz
TCL0 input high, low width	t <sub>TIH0</sub> , t <sub>TIL0</sub>	V <sub>DD</sub> = 2.7 V to 5.5 V	0.48	–	–	μs
		V <sub>DD</sub> = 1.8 V to 5.5 V	1.8			
SCK cycle time	t <sub>KCY</sub>	V <sub>DD</sub> = 2.7 V to 5.5 V External SCK source	800	–	–	ns
		Internal SCK source	650			
		V <sub>DD</sub> = 1.8 V to 5.5 V External SCK source	3200			
		Internal SCK source	3800			
SCK high, low width	t <sub>KH</sub> , t <sub>KL</sub>	V <sub>DD</sub> = 1.8 V to 5.5 V External SCK source	400	–	–	ns
		Internal SCK source	t <sub>KCY</sub> /2 – 50			
		V <sub>DD</sub> = 1.8 V to 5.5 V External SCK source	1600			
		Internal SCK source	t <sub>KCY</sub> /2 – 150			
SI setup time to SCK high	t <sub>SIK</sub>	External SCK source	100	–	–	ns
		Internal SCK source	150			
SI hold time to SCK high	t <sub>KSI</sub>	External SCK source	400	–	–	ns
		Internal SCK source	400			
Output delay for SCK to SO	t <sub>KSO</sub>	V <sub>DD</sub> = 2.7 V to 5.5 V External SCK source	–	–	300	ns
		Internal SCK source			250	
		V <sub>DD</sub> = 1.8 V to 5.5 V External SCK source			1000	
		Internal SCK source			1000	
Interrupt input high, low width	t <sub>INTH</sub> , t <sub>INTL</sub>	INT0	(2)	–	–	μs
		INT1, INT2, INT4, KS0-KS7	10			
RESET Input Low Width	t <sub>RSL</sub>	Input	10	–	–	μs

**NOTES:**

1. Unless otherwise specified, Instruction Cycle Time condition values assume a main system clock (fx) source.
2. Minimum value for INT0 is based on a clock of 2t<sub>CY</sub> or 128/fx as assigned by the IMOD0 register setting.

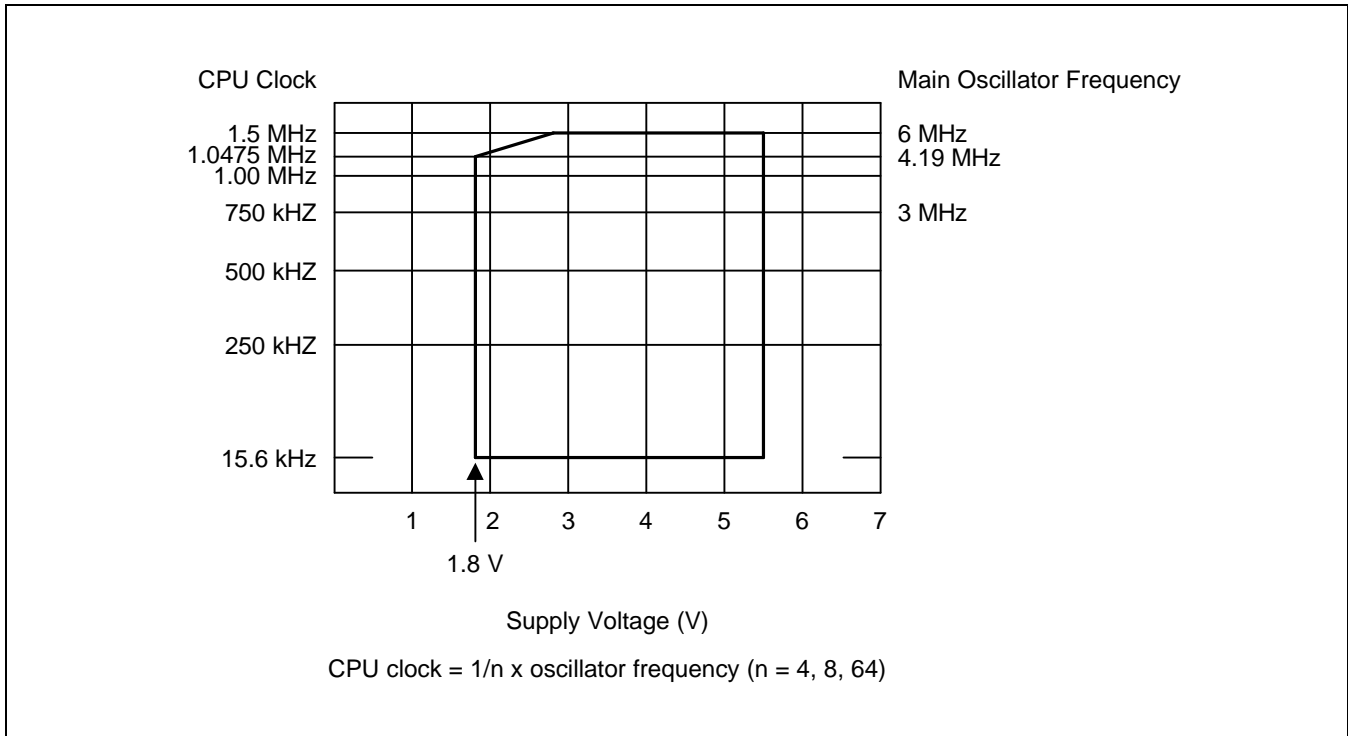

Figure 16-2. Standard Operating Voltage Range

Table 16-10. RAM Data Retention Supply Voltage in Stop Mode

(T<sub>A</sub> = -40 °C to +85 °C)

Parameter	Symbol	Conditions	Min	Typ	Max	Unit
Data retention supply voltage	V <sub>DDDR</sub>	Normal operation	1.8	–	6.5	V
Data retention supply current	I <sub>DDDR</sub>	V <sub>DDDR</sub> = 1.8 V	–	0.1	10	μs
Release signal set time	t <sub>SREL</sub>	Normal operation	0	–	–	μs
Oscillator stabilization wait time (1)	t <sub>WAIT</sub>	Released by RESET	–	2 <sup>17</sup> /f <sub>x</sub>	–	ms
		Released by interrupt	–	(2)	–	

**NOTES:**

1. During oscillator stabilization wait time, all CPU operations must be stopped to avoid instability during oscillator start-up.
2. Use the basic timer mode register (BMOD) interval timer to delay execution of CPU instructions during the wait time.

TIMING WAVEFORMS

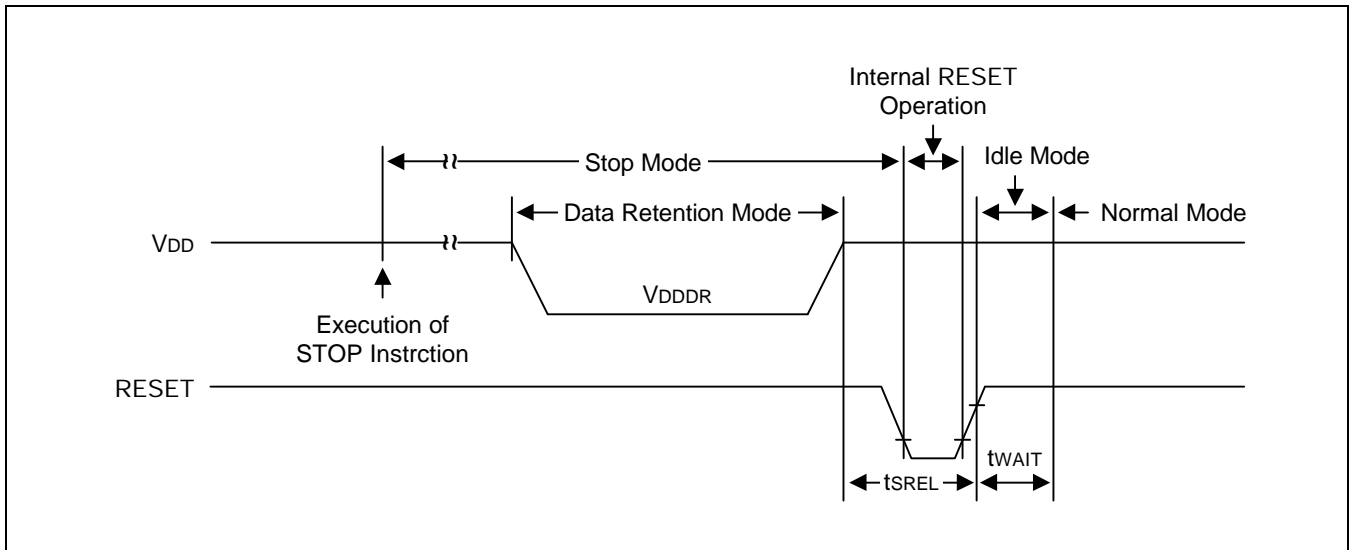

Figure 16-3. Stop Mode Release Timing When Initiated By RESET

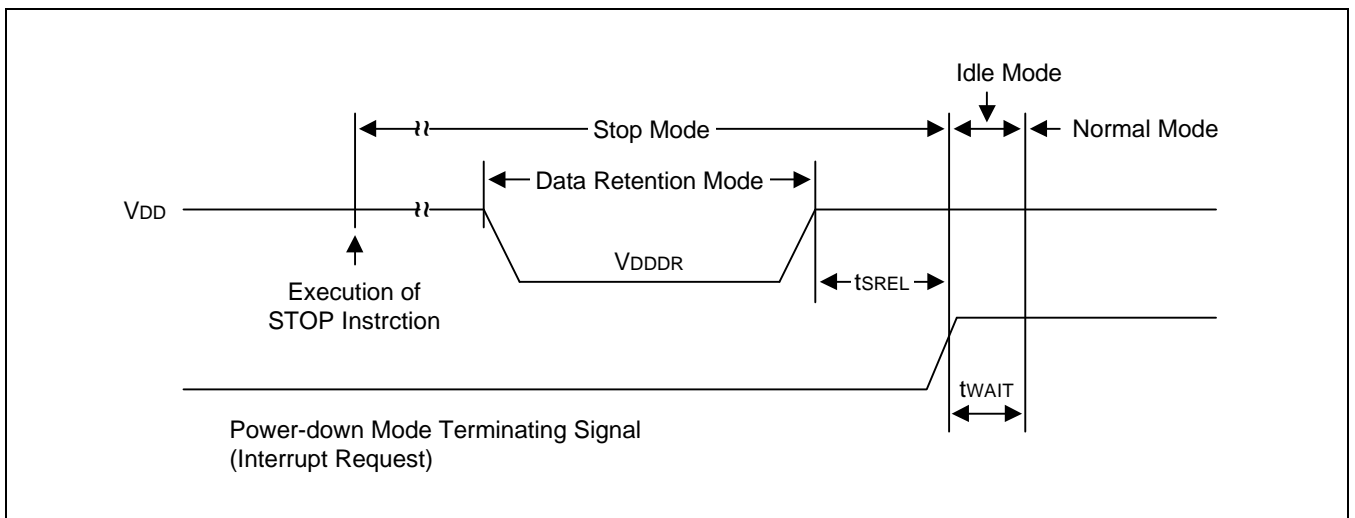

Figure 16-4. Stop Mode Release Timing When Initiated By Interrupt Request

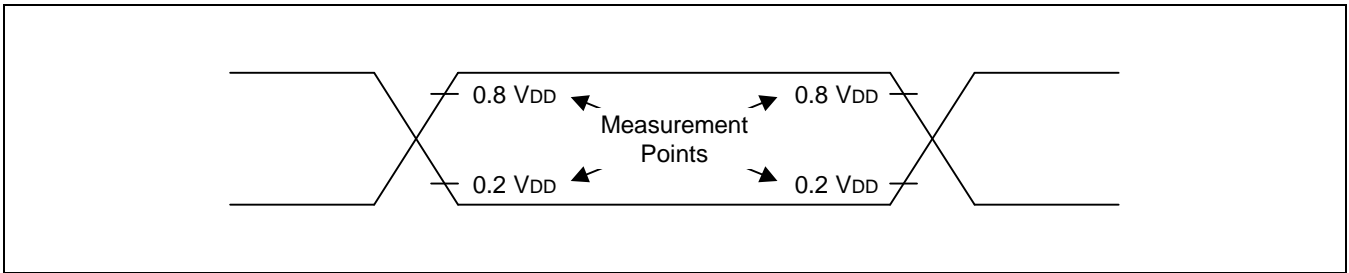

Figure 16-5. A.C. Timing Measurement Points (Except for  $X_{IN}$  and  $XT_{IN}$ )

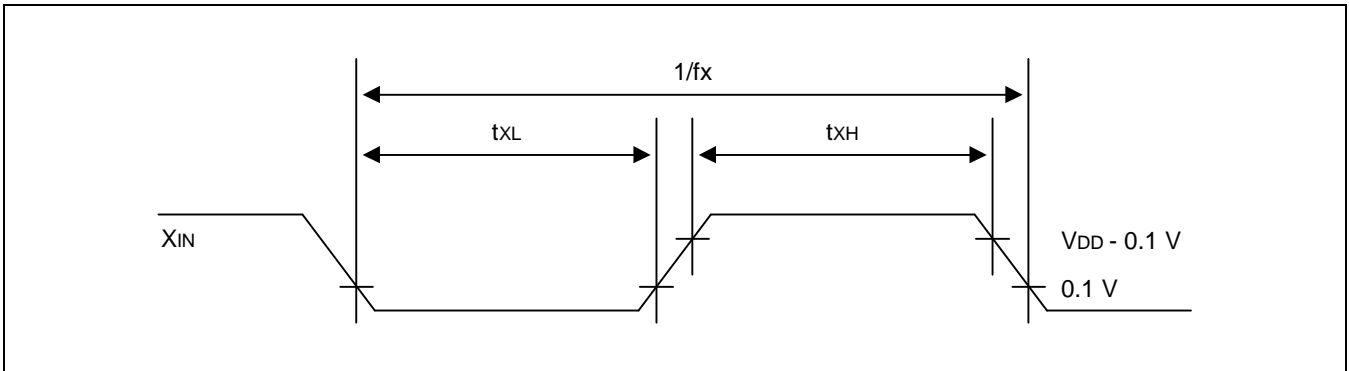

Figure 16-6. Clock Timing Measurement at  $X_{IN}$

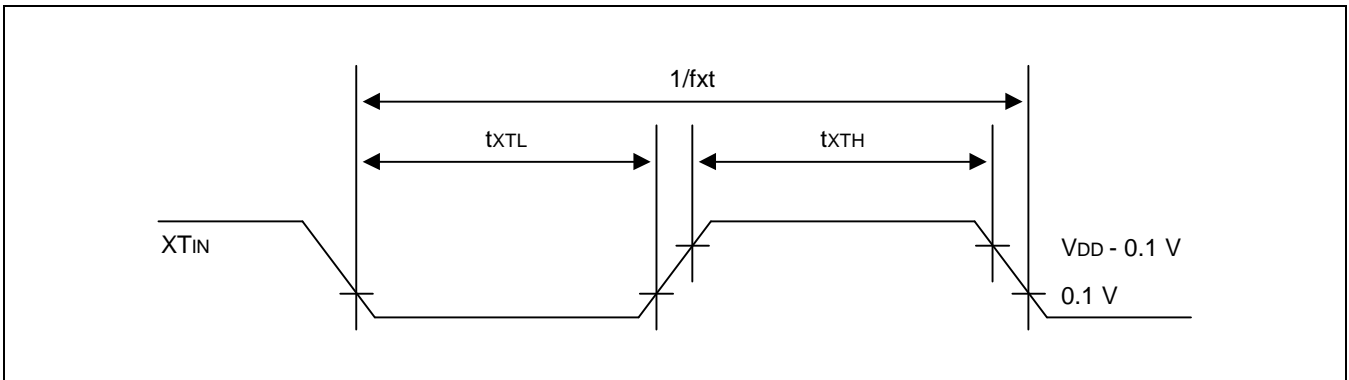

Figure 16-7. Clock Timing Measurement at  $XT_{IN}$

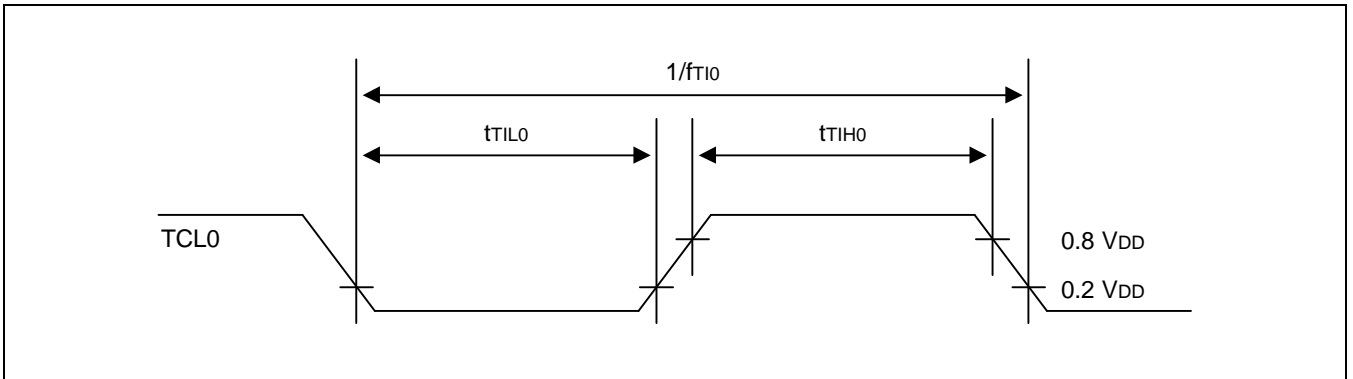

Figure 16-8. TCL0 Timing

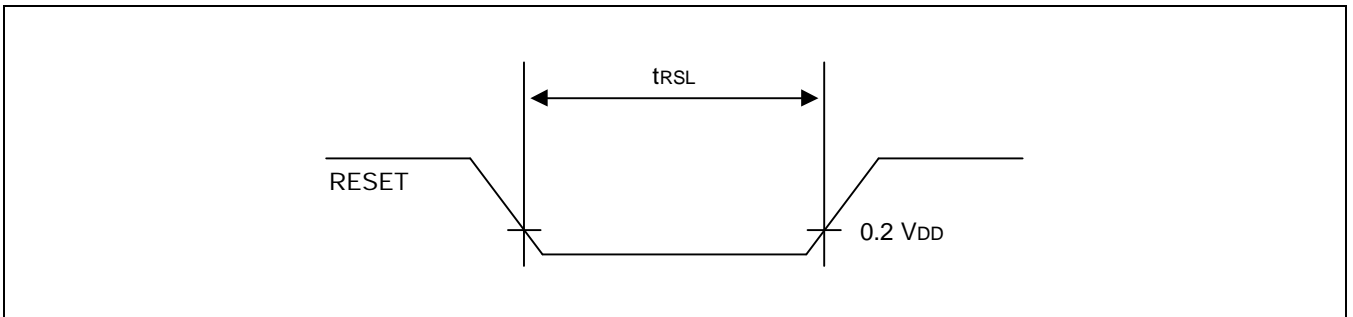

Figure 16-9. Input Timing for RESET Signal

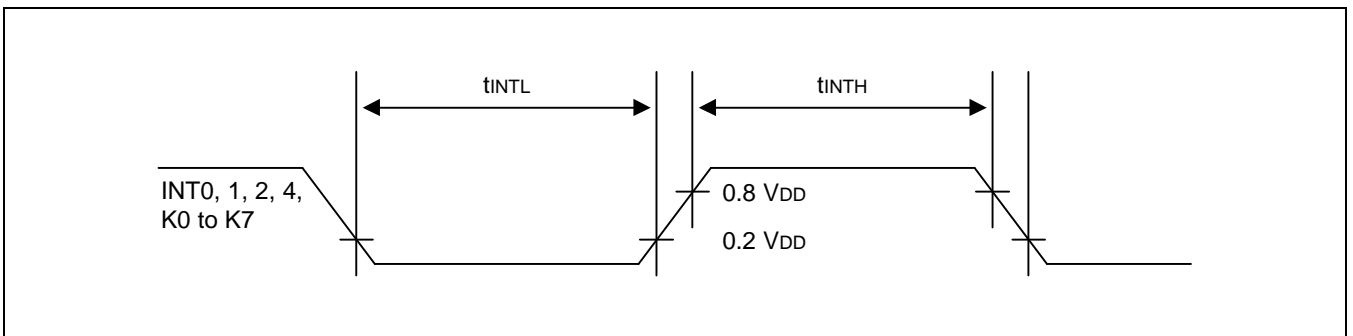

Figure 16-10. Input Timing for External Interrupts and Quasi-Interrupts

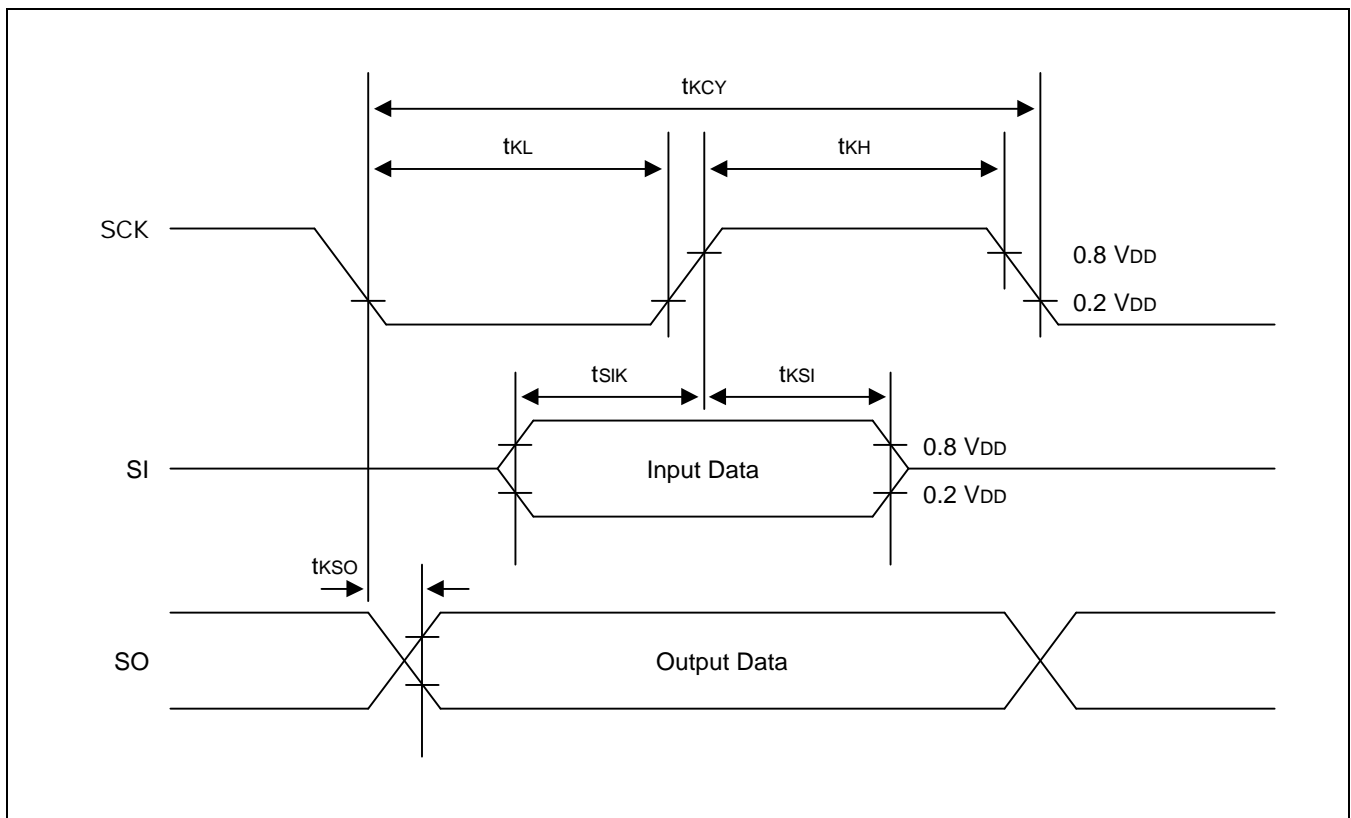

Figure 16-11. Serial Data Transfer Timing

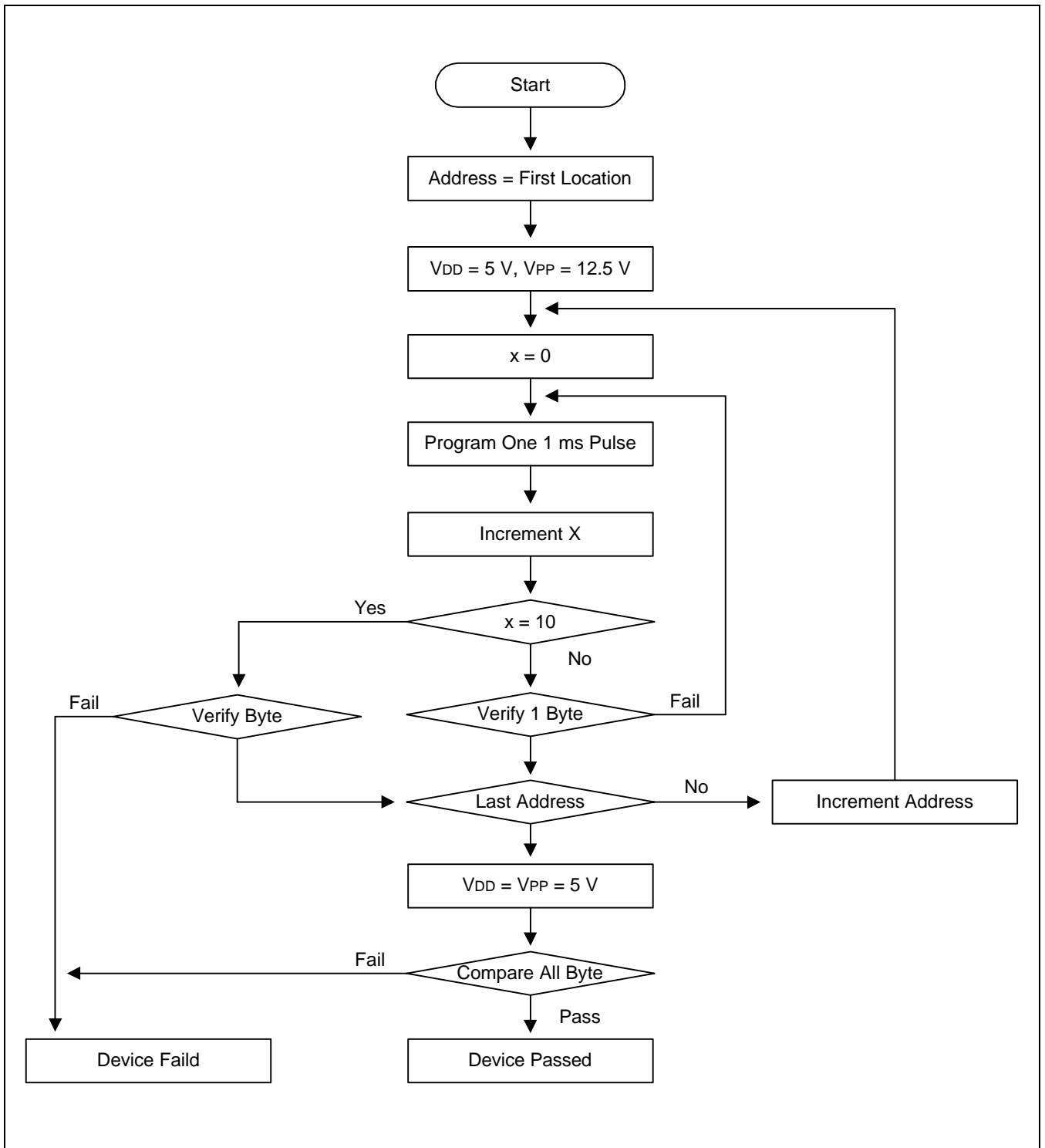

Figure 16-12. OTP Programming Algorithm

## NOTES