

High Voltage Transistor

PNP Silicon

MMBT5401

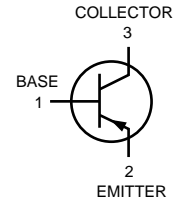
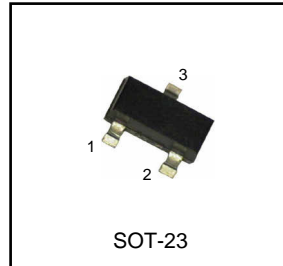

MAXIMUM RATINGS

Rating	Symbol	Value	Unit
Collector-Emitter Voltage	V _{CEO}	-150	V _{dc}
Collector-Base Voltage	V _{CBO}	-160	V _{dc}
Emitter-Base Voltage	V _{EBO}	-5.0	V _{dc}
Collector Current-Continuous	I _C	-500	mAdc

THERMAL CHARACTERISTICS

Characteristic	Symbol	Max.	Unit
Total Device Dissipation FR-5 Board ⁽¹⁾ T _A =25°C Derate above 25°C	P _D	225 1.8	mW mW / °C
Thermal Resistance Junction to Ambient	R _{θJA}	556	°C / W
Total Device Dissipation Alumina Substrate, ⁽²⁾ T _A =25°C Derate above 25°C	P _D	300 2.4	mW mW / °C
Thermal Resistance Junction to Ambient	R _{θJA}	417	°C / W
Junction and Storage Temperature	T _J ,T _{STG}	-55 to +150	°C

DEVICE MARKING

MMBT5401=2L

ELECTRICAL CHARACTERISTICS (T_A=25°C unless otherwise noted)

Characteristic	Symbol	Min.	Max.	Unit
----------------	--------	------	------	------

OFF CHARACTERISTICS

Collector-Emitter Breakdowe Voltage (I _C = 1.0mAdc, I _B = 0)	V _{(BR)CEO}	-150	-	V _{dc}
Collector-Base Breakdowe Voltage (I _C = -100 uAdc, I _E = 0)	V _{(BR)CBO}	-160	-	V _{dc}
Emitter-Base Breakdowe Voltage (I _E = -10 uAdc, I _C = 0)	V _{(BR)EBO}	-5.0	-	V _{dc}
Collector Cutoff Current (V _{CE} = -120 V _{dc} , I _E = 0) (V _{CE} = -120 V _{dc} , I _E = 0, T _A = 100 °C)	I _{CES}	-	-50 -50	nAdc uAdc

(1) FR-5=1.0 x 0.75 x 0.062in.

(2) Alumina=0.4 x 0.3 x 0.024in. 99.5% alumina.

ELECTRICAL CHARACTERISTICS (TA=25°C unless otherwise noted) (Continued)

Characteristic	Symbol	Min.	Max.	Unit
----------------	--------	------	------	------

ON CHARACTERISTICS

DC Current Gain (IC= -1.0 mA _{dc} , VCE= -5.0 V _{dc}) (IC= -10 mA _{dc} , VCE= -5.0 V _{dc}) (IC= -50 mA _{dc} , VCE= -5.0 V _{dc})	HFE	50 60 50	- 240 -	-
Collector-Emitter Saturation Voltage (IC= -10 mA _{dc} , IB= -1.0 mA _{dc}) (IC= -50 mA _{dc} , IB= -5.0 mA _{dc})	VCE(sat)	- -	-0.2 -0.5	V _{dc}
Base-Emitter Saturation Voltage (IC= -10 mA _{dc} , IB= -1.0 mA _{dc}) (IC= -50 mA _{dc} , IB= -5.0 mA _{dc})	VBE(sat)	- -	-1.0 -1.0	V _{dc}

SMALL-SIGNAL CHARACTERISTIC

Current-Gain-Bandwidth Product (IC= -10 mA _{dc} , VCE= -10 V _{dc} , f=100 MHz)	f _T	100	300	MHz
Output Capacitance (VCB= -10 V _{dc} , IE=0, f=1.0 MHz)	C _{cb}	-	6.0	pF
Small-Signal Current Gain (VCE= -10 V _{dc} , IC= -1.0 mA _{dc} , f=1.0 MHz)	h _{fe}	40	200	-
Noise Figure (VCE= -5.0 V _{dc} , IC= -200 uA _{dc} , RS= 10 ohms, f=1.0 kHz)	NF	-	8.0	dB

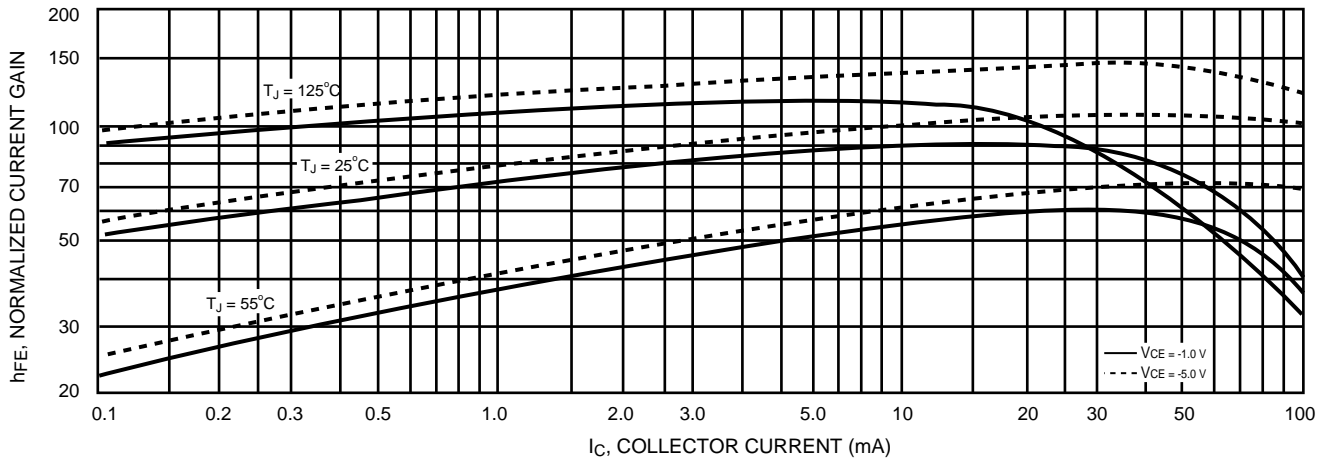

Figure 1. DC Current Gain

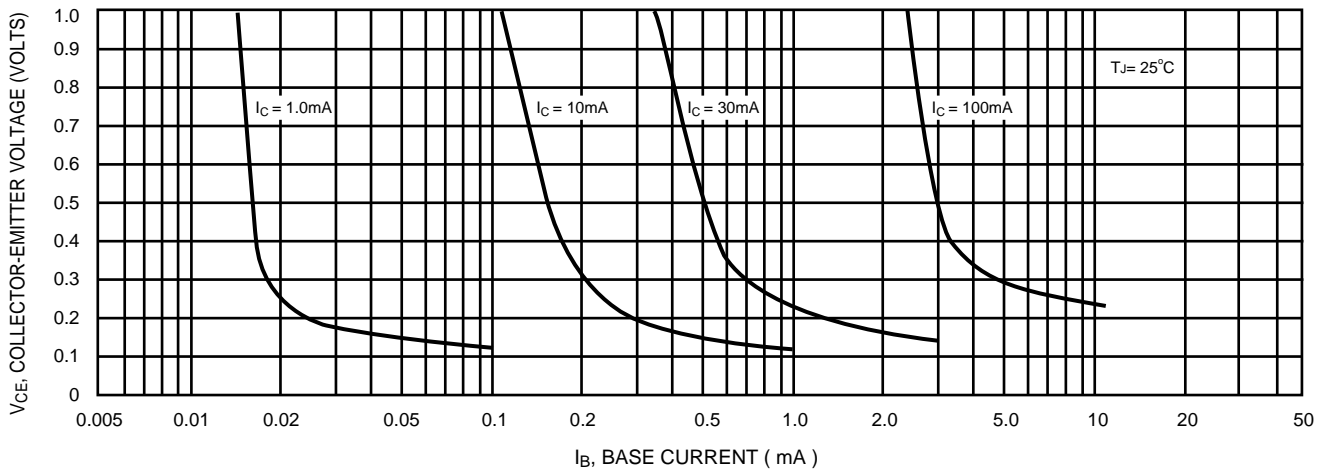

Figure 2. Collector Saturation Region

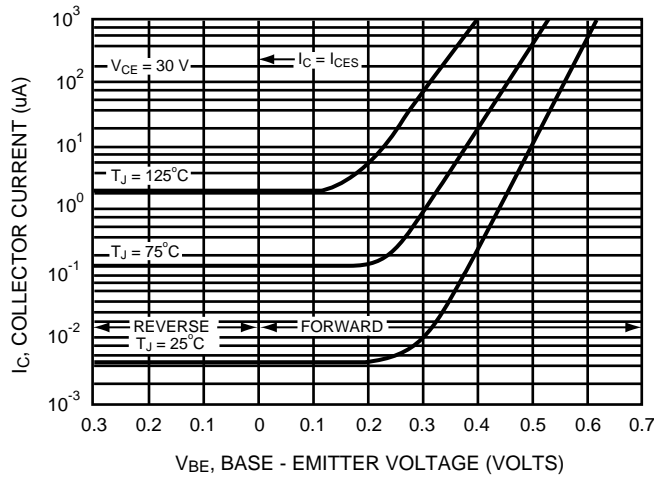

Figure 18. Temperature Coefficients

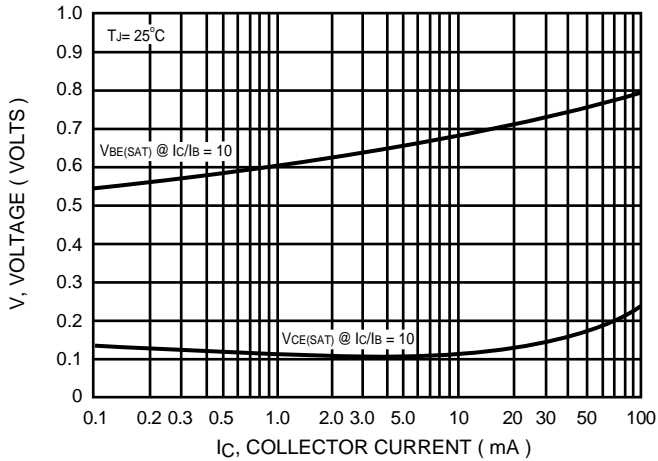

Figure 4. " On " Voltages

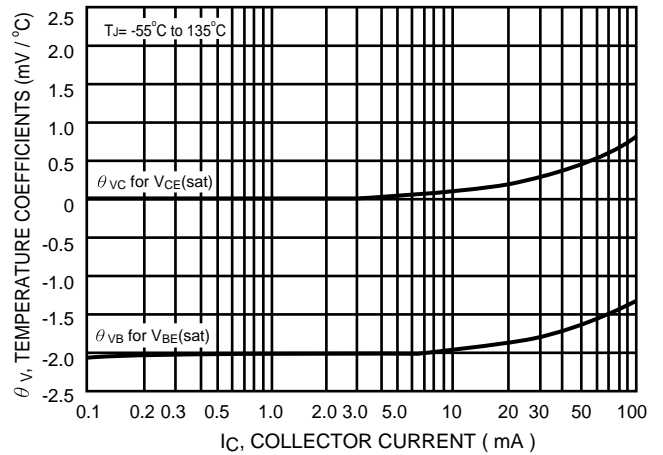
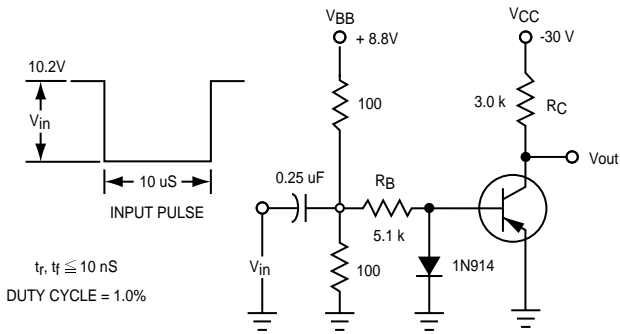

Figure 5. Temperature Coefficients



VALUES SHOWN ARE FOR IC @ 10 mA
Figure 6. Switching Time Test Circuit

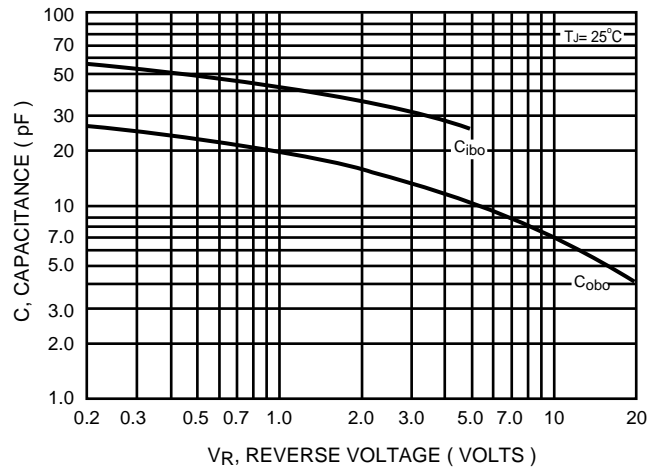

Figure 7. Capacitances

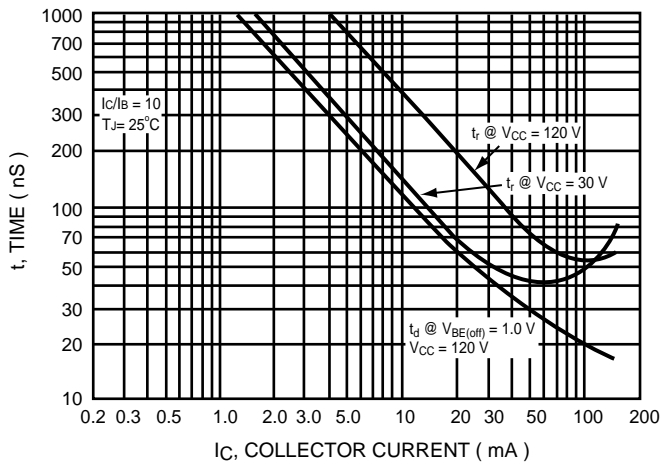

Figure 8. Turn - On Time

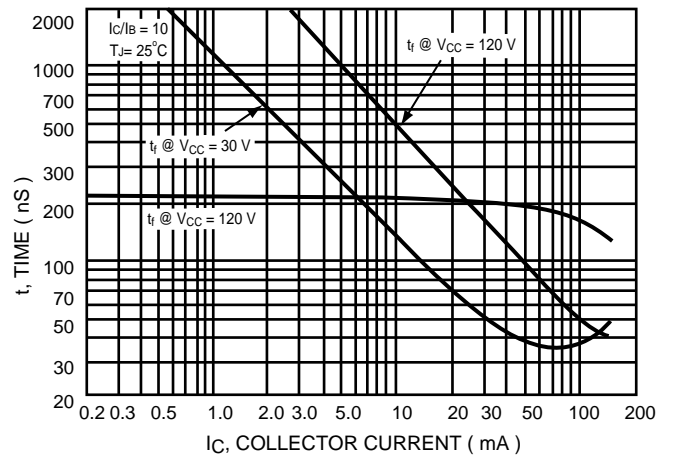

Figure 9. Turn - Off Time