

Hyper 5 mm (T1) LED, Non Diffused Hyper-Bright LED

LS 5436, LA 5436, LO 5436
LY 5436

Besondere Merkmale

- eingefärbtes, diffuses Gehäuse
- zur Einkopplung in Lichtleiter
- als optischer Indikator einsetzbar
- Lötspieße mit Aufsetzebene
- gegurtet lieferbar
- Störimpulsfest nach DIN 40839

Features

- colored, diffused package
- optical coupling into light pipes
- for use as optical indicator
- solder leads with stand-off
- available taped on reel
- load dump resistant acc. to DIN 40839

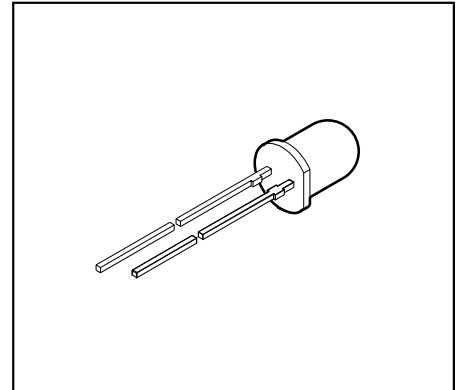

| Typ Type | Emissionsfarbe Color of Emission | Gehäusefarbe Color of Package | Lichtstärke Luminous Intensity $I_F = 20 \text{ mA}$ I_V (mcd) | Bestellnummer Ordering Code |
|-------------|--|-------------------------------------|--|--------------------------------|
| LS 5436-SO | super-red | colorless clear | ≥ 160 (350 typ.) | Q62703-Q3626 |
| LA 5436-TO | amber | colorless clear | ≥ 250 (500 typ.) | Q62703-Q3919 |
| LO 5436-TO | orange | colorless clear | ≥ 250 (500 typ.) | Q62703-Q3628 |
| LY 5436-TO | yellow | colorless clear | ≥ 250 (500 typ.) | Q62703-Q3630 |

Streuung der Lichtstärke in einer Verpackungseinheit $I_{V \max} / I_{V \min} \leq 2.0$.
Luminous intensity ratio in one packaging unit $I_{V \max} / I_{V \min} \leq 2.0$.

Grenzwerte Maximum Ratings

| Bezeichnung Parameter | Symbol Symbol | Werte Values | | Einheit Unit |
|--|------------------|-----------------|-----|-----------------|
| | | LS, LO, LA | LY | |
| Betriebstemperatur Operating temperature range | T_{op} | - 55 ... + 100 | | °C |
| Lagertemperatur Storage temperature range | T_{stg} | - 55 ... + 100 | | °C |
| Sperrschichttemperatur Junction temperature | T_j | + 100 | | °C |
| Durchlaßstrom Forward current | I_F | 30 | 20 | mA |
| Stoßstrom Surge current $t \leq 10 \mu s, D = 0.005$ | I_{FM} | 1 | 0.2 | A |
| Sperrspannung ¹⁾ Reverse voltage ¹⁾ | V_R | 3 | | V |
| Verlustleistung Power dissipation $T_A \leq 25 \text{ °C}$ | P_{tot} | 80 | 55 | mW |
| Wärmewiderstand Thermal resistance Sperrschicht / Umgebung Junction / air | $R_{th JA}$ | 500 | | K/W |

1) Belastung in Sperrichtung sollte vermieden werden.

1) Reverse biasing should be avoided.

Kennwerte ($T_A = 25\text{ °C}$)

Characteristics

| Bezeichnung Parameter | Symbol Symbol | Werte Values | | | | Einheit Unit |
|---|--|-----------------|------------|------------|------------|--------------------------------|
| | | LS | LA | LO | LY | |
| Wellenlänge des emittierten Lichtes Wavelength at peak emission $I_F = 20\text{ mA}$ | (typ.) λ_{peak} (typ.) | 645 | 622 | 610 | 591 | nm |
| Dominantwellenlänge Dominant wavelength $I_F = 20\text{ mA}$ | (typ.) λ_{dom} (typ.) | 632 | 615 | 605 | 587 | nm |
| Spektrale Bandbreite bei 50% $I_{\text{rel max}}$ Spectral bandwidth at 50% $I_{\text{rel max}}$ $I_F = 20\text{ mA}$ | (typ.) $\Delta\lambda$ (typ.) | 16 | 16 | 16 | 15 | nm |
| Abstrahlwinkel bei 50% I_v (Vollwinkel) Viewing angle at 50% I_v | 2φ | 30 | 30 | 30 | 30 | Grad deg. |
| Durchlaßspannung Forward voltage $I_F = 20\text{ mA}$ | (typ.) V_F (max.) V_F | 2.0 2.6 | 2.0 2.6 | 2.0 2.6 | 2.0 2.6 | V V |
| Sperrstrom Reverse current $V_R = 3\text{ V}$ | (typ.) I_R (max.) I_R | 0.01 10 | 0.01 10 | 0.01 10 | 0.01 10 | μA μA |
| Temperaturkoeffizient von λ_{dom} ($I_F = 20\text{ mA}$) Temperature coefficient of λ_{dom} ($I_F = 20\text{ mA}$) | TC_λ | 0.014 | 0.062 | 0.067 | 0.096 | nm/K |
| Temperaturkoeffizient von λ_{peak} , $I_F = 20\text{ mA}$ Temperature coefficient of λ_{peak} , $I_F = 20\text{ mA}$ | (typ.) TC_λ (typ.) | 0.14 | 0.13 | 0.13 | 0.13 | nm/K |
| Temperaturkoeffizient von V_F , $I_F = 20\text{ mA}$ Temperature coefficient of V_F , $I_F = 20\text{ mA}$ | (typ.) TC_V (typ.) | - 1.95 | - 1.78 | - 1.67 | - 2.51 | mV/K |

Relative spektrale Emission $I_{rel} = f(\lambda)$, $T_A = 25\text{ °C}$, $I_F = 20\text{ mA}$

Relative spectral emission

$V(\lambda)$ = spektrale Augenempfindlichkeit

Standard eye response curve

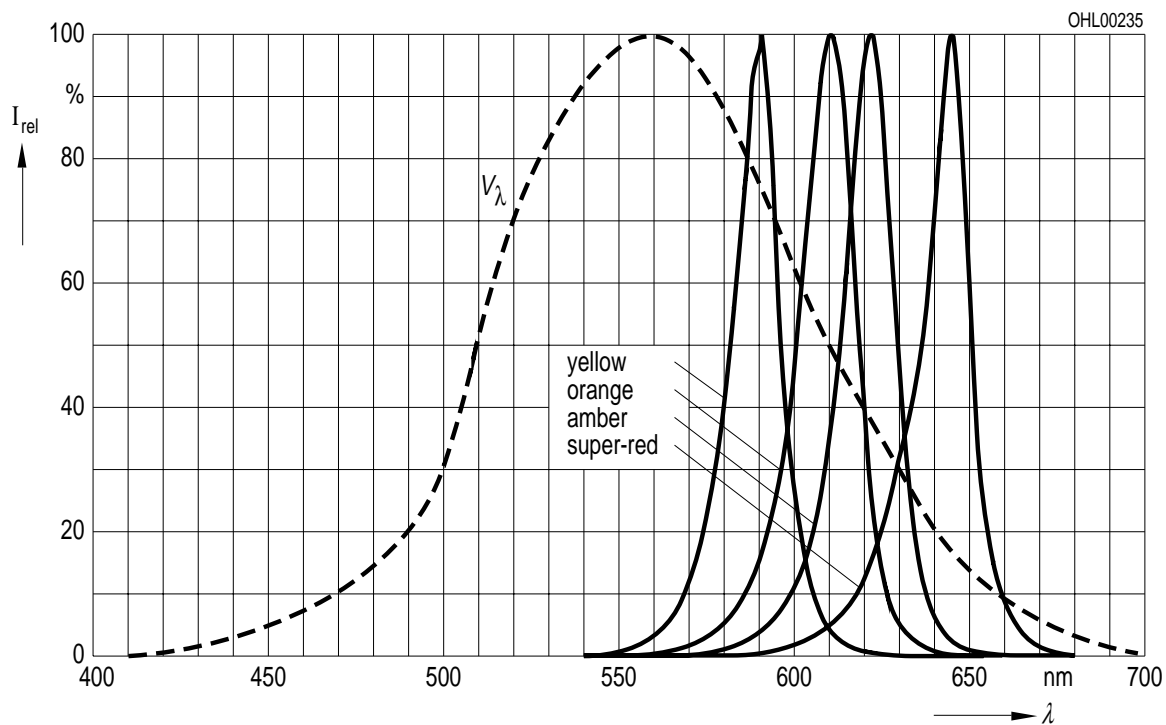

Abstrahlcharakteristik $I_{rel} = f(\varphi)$

Radiation characteristic

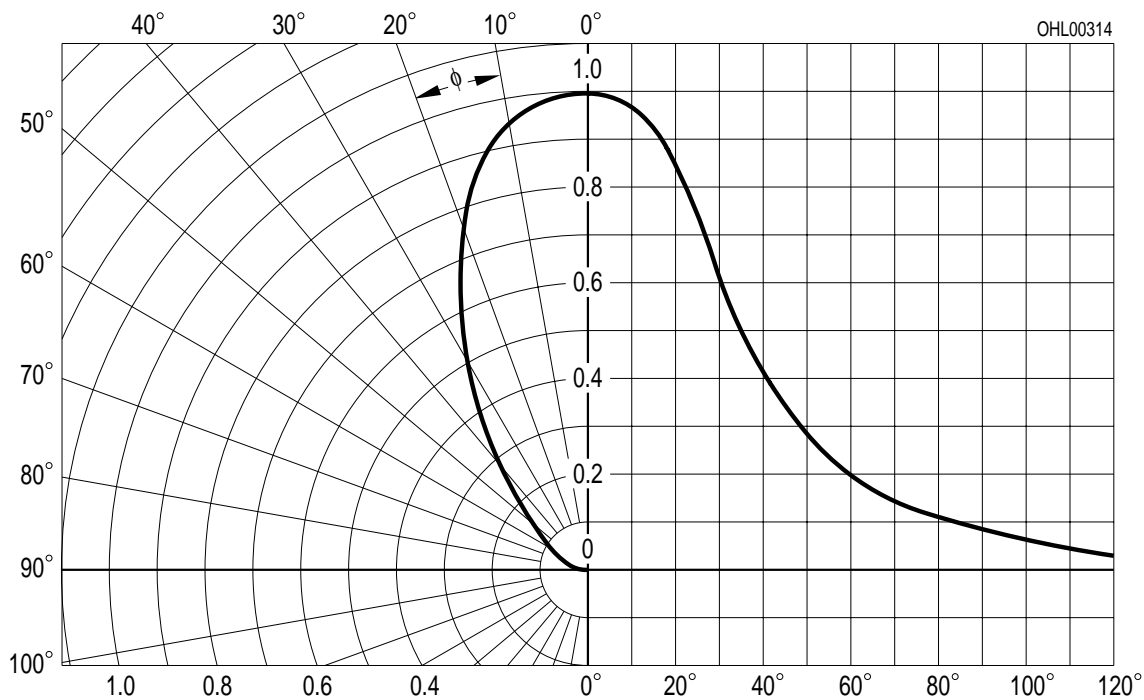

Durchlaßstrom $I_F = f(V_F)$

Forward current

$T_A = 25^\circ\text{C}$

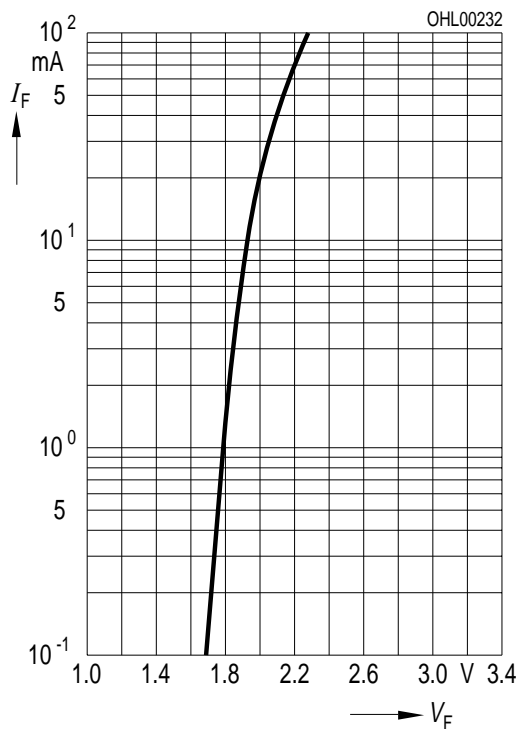

Maximal zulässiger Durchlaßstrom

Max. permissible forward current

$I_F = f(T_A)$

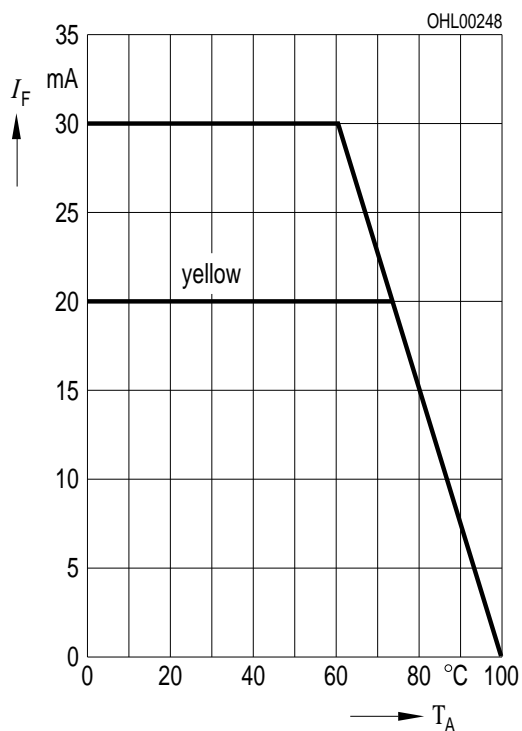

Relative Lichtstärke $I_V / I_{V(20\text{ mA})} = f(I_F)$

Relative luminous intensity

$T_A = 25^\circ\text{C}$

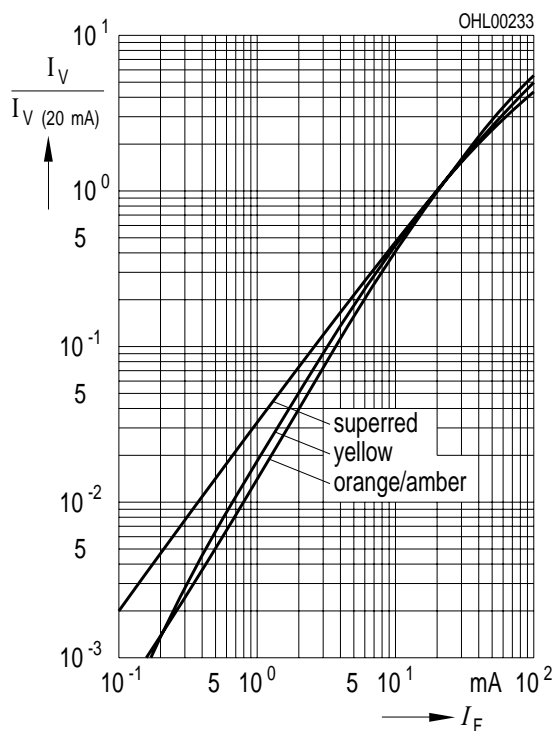

Relative Lichtstärke $I_V / I_{V(25^\circ\text{C})} = f(T_A)$

Relative luminous intensity

$I_F = 20\text{ mA}$

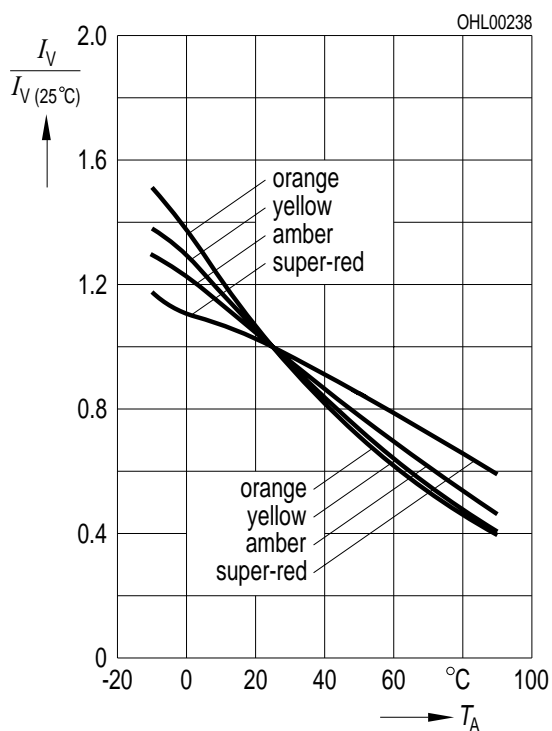

Zulässige Impulsbelastbarkeit $I_F = f(t_p)$
Permissible pulse handling capability
LS, LA, LO

Duty cycle $D =$ parameter, $T_A = 25\text{ °C}$

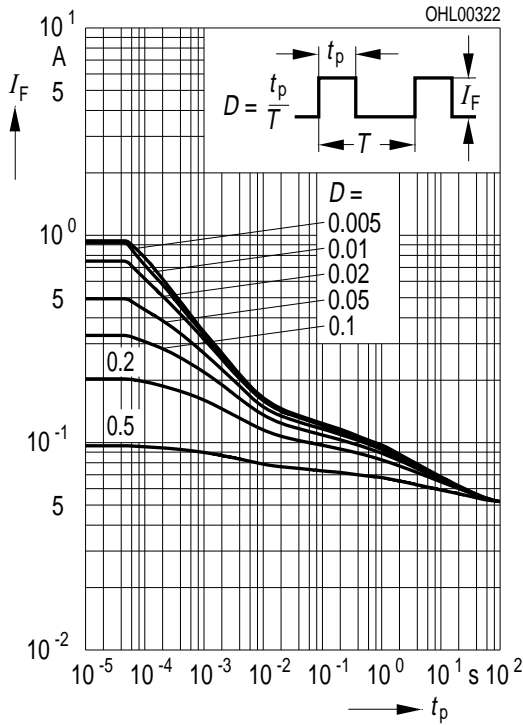

Zulässige Impulsbelastbarkeit $I_F = f(t_p)$
Permissible pulse handling capability
LY

Duty cycle $D =$ parameter, $T_A = 25\text{ °C}$

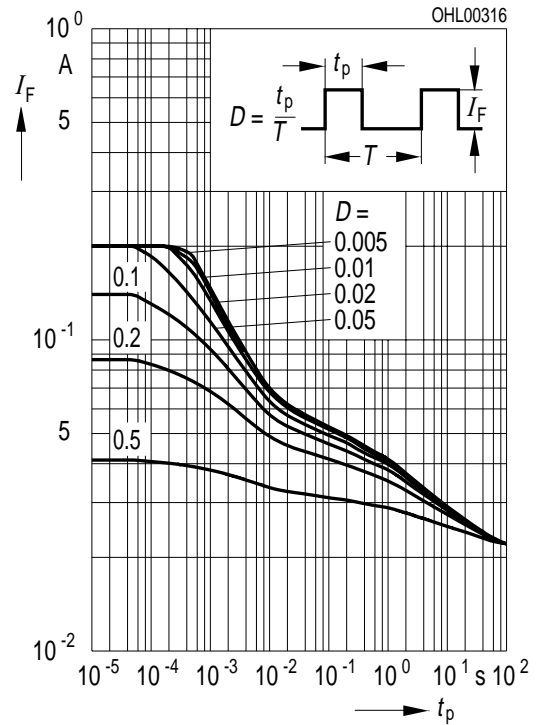

Maßzeichnung
Package Outlines

(Maße in mm, wenn nicht anders angegeben)
 (Dimensions in mm, unless otherwise specified)

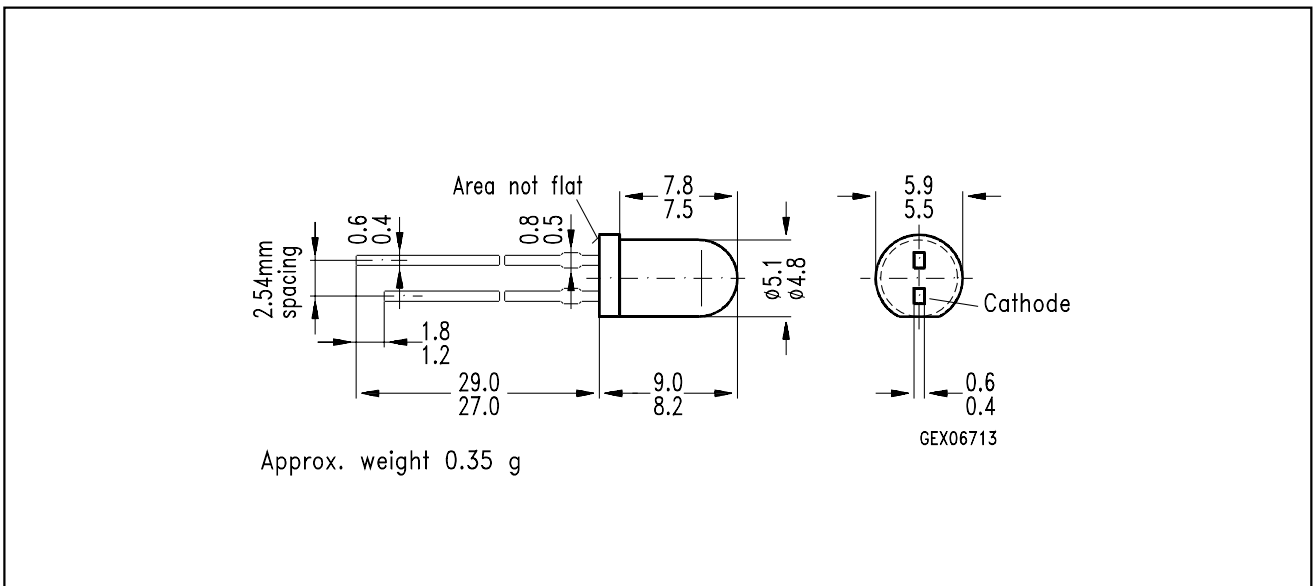

Kathodenkennzeichnung: Kürzerer Lötspieß
Cathode mark: Short solder lead