

YSS901

SD

Preliminary

Stereo dipole

■ Outline

YSS901 is a device that uses the stereo dipole system (SD) with which the transaural system can be constructed. When a stereophonic signal that has been processed with the SD system of this device is inputted to two speakers located adjacently at the center of the field (or to two speakers contained in one cabinet), the virtual sound positioning function of this system produces the stereophonic sound similar to the one that can be obtained by using an ordinary stereophonic sound replay system through the central two speakers.

YSS901 has built-in one bit Delta-Sigma type A/D and D/A converters for each of the two channels at its input and output respectively. Thanks to these built-in converters, this device can process analog stereophonic sound signal through the converters in addition to digital stereophonic sound signal.

This device performs an advanced convolution through DSP using the FIR filter.

■ Features

- Two channel virtual sound positioning by using the stereo dipole system.
- Processes analog or digital signals at each of the two channels.
- Four types of digital data format are available, including 48 fs Serial-DAC16, 18 and 20 bits, and 64 fs.
- Six types of parameter coefficients are built in the device. Additional parameter coefficients can be downloaded externally.
- The parameter control is made through the DC switches or synchronous three-wire serial system.
- Uses a clock of 2.822 MHz from the crystal. External clock can also be used.
- Has a built-in PLL circuit for generating clock for operation.
- Internal operating frequency of 512 fs.
- Allows fading in or out the output of the results of the convolution when switching the coefficient.
- Power supply voltage: 5 V
- Si-gate CMOS process.
- 64 QFP

■ Pin configuration

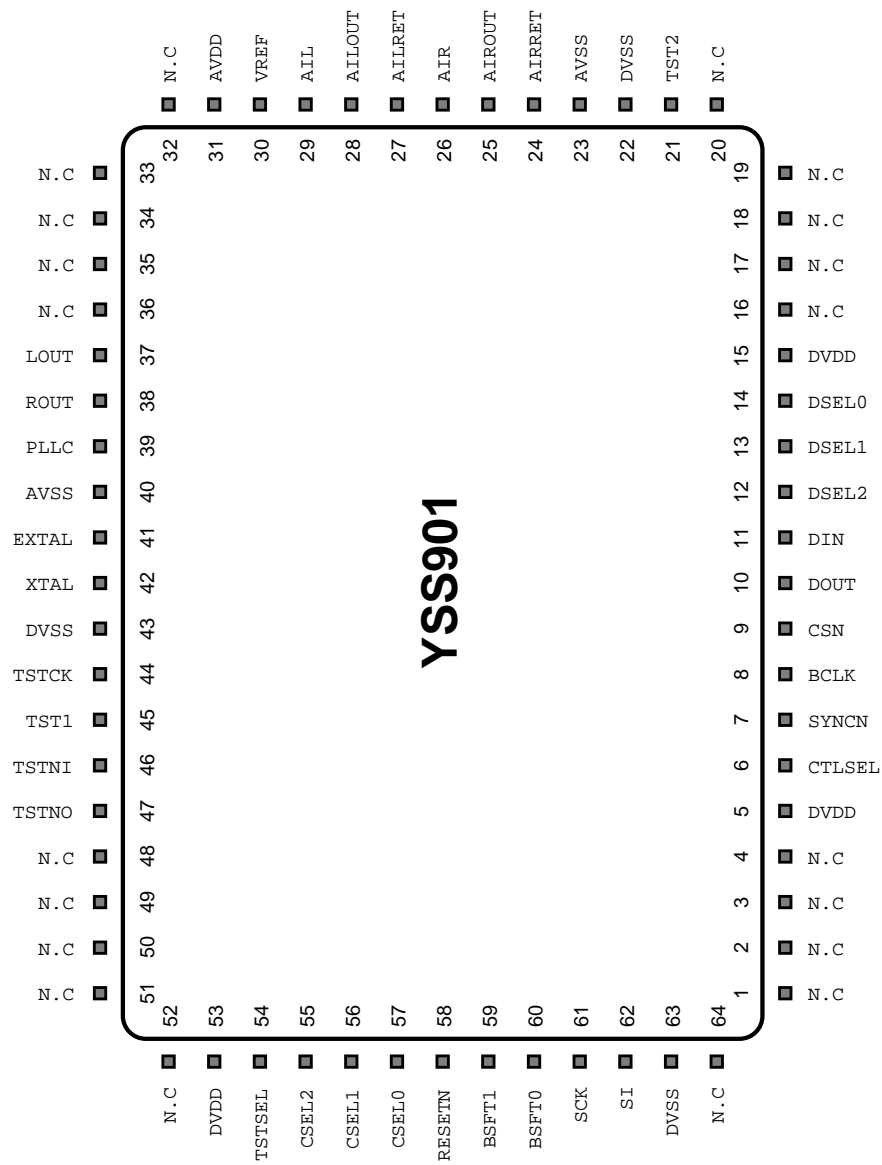

<64QFP TOP VIEW>

■ Pin Description

No.	Pin name	I/O	Function
5	DVDD	-	Digital signal power supply : +5 V
6	CTLSEL	I	Selection of control method
7	SYNCN	I	Digital input/output synchronization signal
8	BCLK	I	Digital input/output bit clock
9	CSN	I	Serial control interface chip select signal
10	DOUT	O	Digital signal output
11	DIN	I	Digital signal input
12	DSEL2	I	Analog/digital input selection
13	DSEL1	I	Digital input/output format selection
14	DSEL0	I	Digital input/output format selection
15	DVDD	-	Digital signal power supply : +5 V
21	TST2	-	Test (To be open.)
22	DVSS	-	Digital signal ground
23	AVSS	-	Analog signal ground
24	AIRRET	AO	Right channel analog signal input return
25	AIROUT	AO	Right channel analog signal input out
26	AIR	AI	Right channel analog signal input
27	AILRET	AO	Left channel analog signal input return
28	AILOUT	AO	Left channel analog signal input out
29	AIL	AI	Left channel analog signal input
30	VREF	AI	Analog signal VREF
31	AVDD	-	Analog signal power supply : +5 V
37	LOUT	AO	Left channel analog signal output
38	ROUT	AO	Right channel analog signal output
39	PLLC	AI	PLL auxiliary input
40	AVSS	-	Analog signal ground
41	EXTAL	I	Crystal clock input
42	XTAL	O	Crystal clock output
43	DVSS	-	Digital signal ground
44	TSTCK	-	Test (Connect with DVSS.)
45	TST1	-	Test (To be open.)
46	TSTNI	I	Test (Connect with DVSS.)
47	TSTNO	O	Test (To be open.)
53	DVDD	-	Digital signal power supply: +5 V
54	TSTSEL	-	Test (Connect with DVSS.)
55	CSEL2	I	Coefficient selection (Enabled when CTLSEL = 0)
56	CSEL1	I	Coefficient selection (Enabled when CTLSEL = 0)
57	CSEL0	I	Coefficient selection (Enabled when CTLSEL = 0)
58	RESETN	I	Reset signal input
59	BSFT1	I	Bit shift selection (Enabled when CTLSEL = 0)
60	BSFT0	I	Bit shift selection (Enabled when CTLSEL = 0)
61	SCK	I	Serial control interface clock input
62	SI	I	Serial control interface data input
63	DVSS	-	Digital signal ground

Notes:

1. Pins of No. 1 to 4, 16 to 20, 32 to 36, 48 to 52 and 64 are to be open.
2. I: input pin
O: output pin
AI: analog signal input pin
AO: analog output pin.

■ Block Diagram

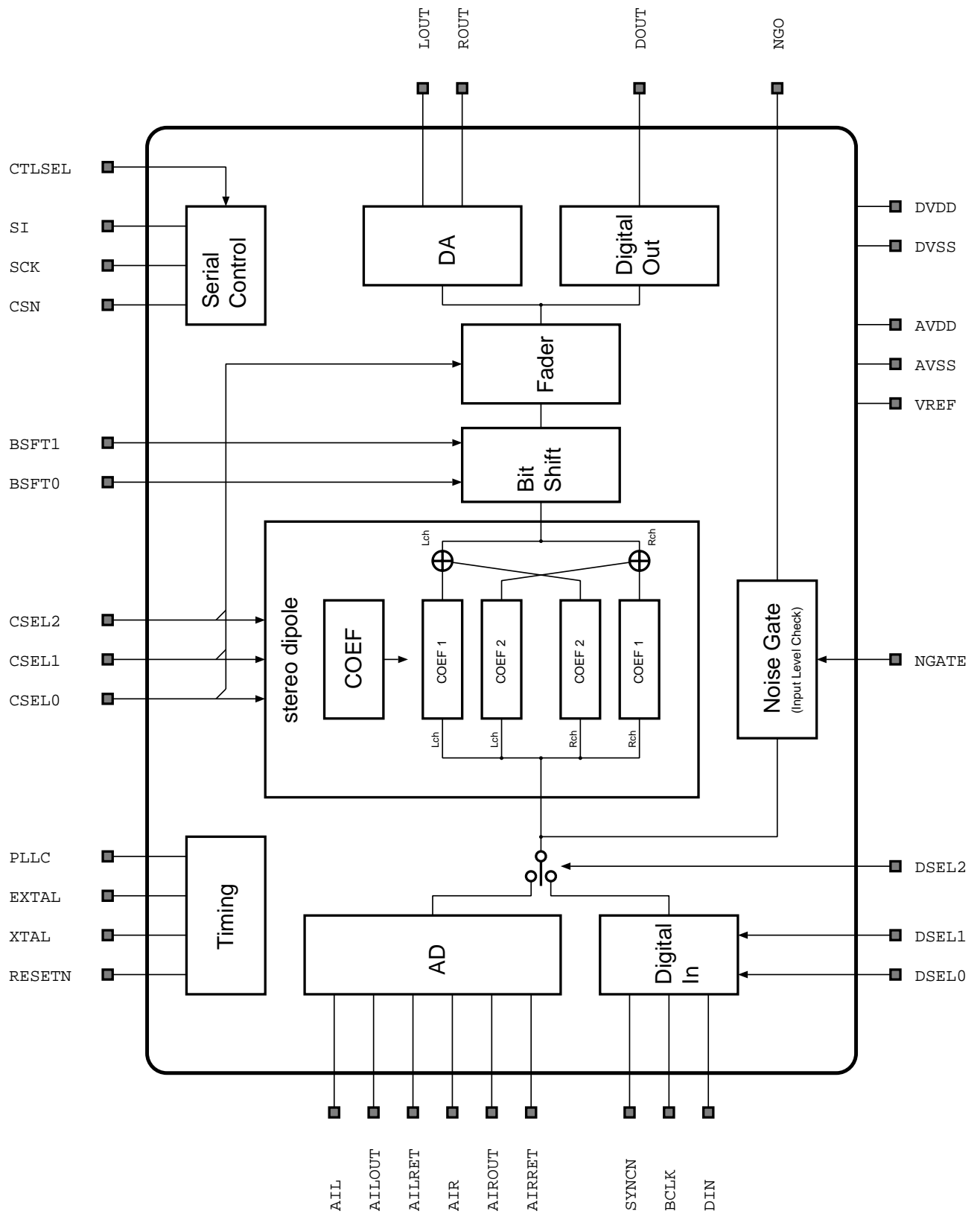

■ Outline of Functions

1. Clock signals

XTAL, EXTAL and PLLC

For the clock signal, use the crystal connected to XTAL EXTAL pin with which the clock signal is obtained by the self-oscillation at the crystal oscillation circuit, or external signal supplied through EXTAL pin. The frequency of the clock obtained by the self-oscillation is 2.822 MHz (or 44.1 kHz * 64). The internal operation is carried out with 512 fs clock that is made by the PLL.

Insert an analog filter in between PLLC and GND pins.

2. Data input/output signals

Analog/digital input selection pin: **DSEL2**

This pin is used to select a type of the input signal. DSEL2 = 0 selects the digital signal input, or DSEL2 = 1 selects the analog signal input.

2-1) Digital signal

Digital signal input/output pins: **DIN, BCLK, SYNCN and DOUT**

Digital signals should be inputted through DIN, BCLK and SYNCN pins.

DIN signal (PCM data) must be in synchronous with BCLK (bit clock) and SYNCN (word clock) signals.

Digital signal is outputted from DOUT pin.

Input/output format designation pins: **DSEL1 and DSEL0**

These pins are used to designate a data format for DAC. The settings of DSEL1 and DSEL0 and their output formats are as follows.

DSEL1	DSEL0	DAC output format		
0	0	48 fs	16 bits	Data LSB justified
0	1	48 fs	18 bits	Data LSB justified (Bits 1 and 0 are "0".)
1	0	48 fs	20 bits	Data LSB justified (Bits 3 through 0 are "0".)
1	1	64 fs	16 bits	Data MSB justified (Delay by one bit)

For the details of the format, refer to "Serial Data Interface" explained later in this document.

2-2) Analog signal

Analog input/output pins: **AIL, AILOUT, AILRET, LOU, AIR, AIROUT, AIRRET and ROUT**

Analog signals should be inputted through AIL and AIR pins. The signals that have been processed by the stereo dipole (SD) are outputted from LOU and ROUT pins respectively. Add an analog filter circuit, an example of which is shown later in this document.

Center voltage pin **VREF**

This pin outputs a reference voltage for analog signal processing. Connect an appropriate capacitor between VREF and GND pins.

3. Controlling functions

3-1) Control method selection pin: **CTLSEL**

This pin is used for selection of a control method as described below.

CTLSEL = 0 : Selection of CSEL2, CSEL1 or CSEL0 by means of DC switch (H/L) is enabled.

CTLSEL = 1 : Selection of CSN, SI or SCK through the microcomputer is enabled.

3-2) Speaker arrangement angle and virtual sound position angle

3-2-1) Setting by means of DC switches: **CSEL2, CSEL1, CSEL0** and **CTLSEL**

By setting CTLSEL to “0”, and setting CSEL 2, 1 and 0 as following, the positioning angle between the front two speakers and the virtual sound positioning angle can be selected.

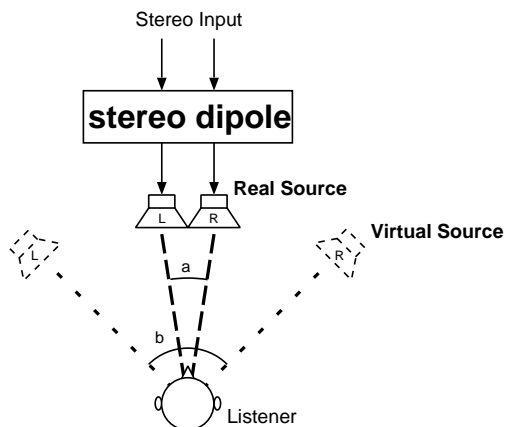

CSEL2	CSEL1	CSEL0	Speaker positioning angle (a)	Virtual sound position (b)
0	0	0	10 degrees	60 degrees
0	0	1	10 degrees	120 degrees
0	1	0	15 degrees	60 degrees
0	1	1	15 degrees	120 degrees
1	0	0	20 degrees	60 degrees
1	0	1	20 degrees	120 degrees
1	1	0	External coefficient	1t downloadable
1	1	1	Through (SD effect is disabled.)	

* Your original coefficients can be written by an external microprocessor. (Technical material is under preparation)

3-2-2) Control through CPU **CSN, SCK, SI** and **CTLSEL**

Data can be written into the control registers through the serial microcomputer interface by using three pins including CSN, SCK and SI.

For the details of the read/write timing, refer to the format diagram shown in the next page.

3-3) Bit shift **BSFT1, BSFT0** and **CTLSEL**

This function is used to specify the amount of bit shift after the addition of the results of filtering.

CTLSEL = 0 enables the settings of BSF1 and BSF0.

The relation between the combinations of settings of BSF1 and BSF0 and the amount of bit shift is as shown below.

BSFT1	BSFT 0	Bit shift
0	0	None
0	1	-1 bit
1	0	-2 bit
1	1	-3 bit

CTLSEL = 1 enables the control of bit shift amount through the microcomputer interface.

4. Initial clear **RESETN**

This LSI requires an initial clear at power on moment.

5. LSI test pins **TST1, TST2, TSTCK, TSTSEL, TSTNI** and **TSTNO**

TST1, TST2 and TST0 are to be open. TSTCK, TSTSEL and TSTNI should be connected with DVSS.

Serial Microcomputer Interface

Format for writing data through microcomputer

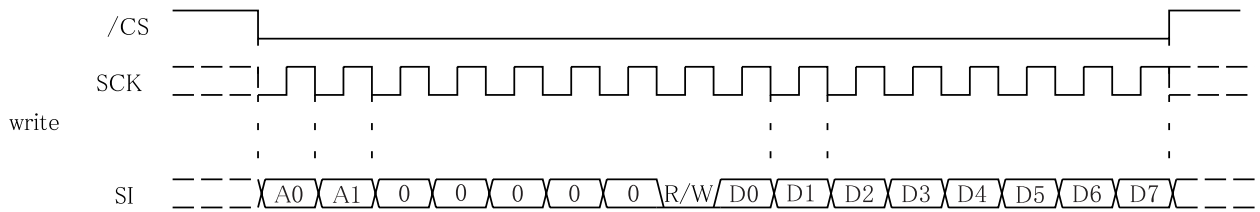

After setting the address (A0 and A1) through SI, it is possible to write data (D0 to D7) into the specified address when R/W bit has been set to “0”. The address map is as shown below.

Address A1, A0	Data	Description
0 0	D0	CSEL0
	D1	CSEL1
	D2	CSEL2
	D3	BSFT0
	D4	BSFT1
	D5 to D7	To be “0”.
0 1	D0	Write address selection
	D1	Write address counter clear
	D2	RAM clear
	D3 to D7	To be “0”.
1 0	D7 to D0	Coefficient data to be written (higher byte)
1 1	D7 to D0	Coefficient data to be written (lower byte)

How to write coefficient data into RAM

Two coefficients are used as a set, each constituted with 16 bits x 125 taps.

The first coefficient (“coef1” shown in the block diagram) is written into RAM address 0-124, and the second one (“coef2” shown in the block diagram) into RAM address 125-249.

The address counter for writing the data uses seven (7) bits, the upper bit (8th bit) uses “write address selection” of D2 with A1, A0 = 0 1.

Data writing procedure

- (1) Clear the RAM and write address counter. (RAM clear needs up to 2 fs to be completed.)
- (2) When the RAM has been cleared, write data into higher byte and then into lower byte starting at the first byte of the first coefficient. (When the writing into the lower byte has been completed, the data is actually written into RAM. Wait 1 fs before writing the data into higher byte of the next coefficient.)
- (3) When the first coefficient has been written, write the second one by using the same procedure. Set the “write address selection” bit to “1” when writing data into the 4th tap and after of the second coefficient.

Serial Data Interface

Timing of the serial data interface as shown below

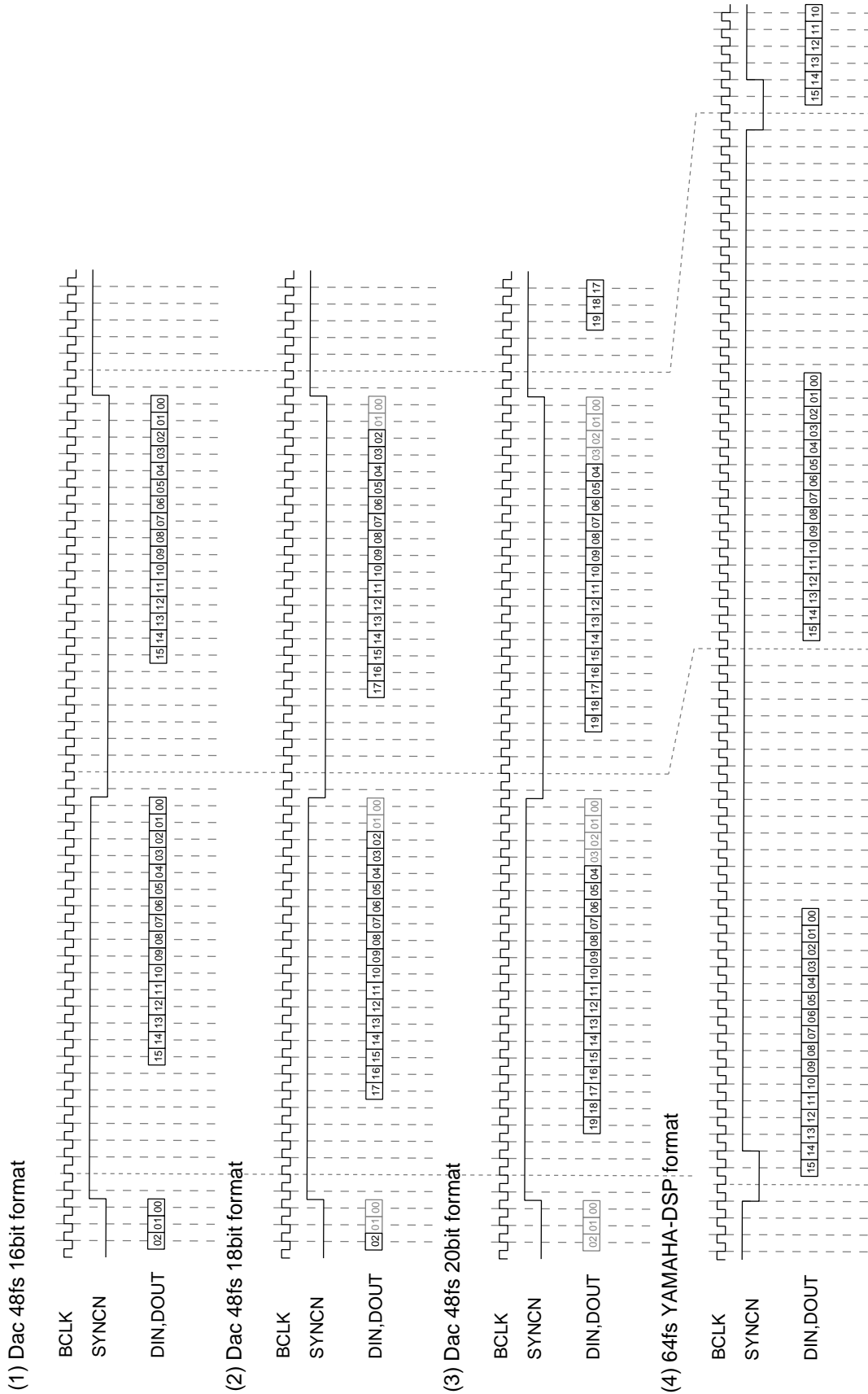

■ Electrical Characteristics

1. Absolute Maximum Rating

Items	Symbol	Min.	Max.	Unit
Power supply Voltage	VDD	V _{SS} -0.5	V _{SS} +7.0	V
Input Voltage	VI	V _{SS} -0.5	VDD1+0.5	V
Input Current	II	-20	+20	mA
Storage Temperature	Tstg	-50	125	°C

2. Recommended Operating Conditions

Items	Symbol	Min.	Typ.	Max.	Unit
Power supply Voltage	VDD	4.75	5.0	5.25	V
Operating Temperature	Top	0	25	70	°C

3. DC Characteristics (Condition: Under Recommended Operating Conditions)

Items	Symbol	Condition	Min.	Typ.	Max.	Unit
Input Voltage H level	VIH2	*1	2.2			V
Input Voltage L level	VIL2	*1			0.8	V
Output Voltage H level	VOH	IOH = -80 μA *2	VDD1-1.0			V
Output Voltage L level	VOL	IOL = 1.6 mA *2			0.4	V
Output Capacitance	CO	*2			50	pF
Power Consumption	PD			500		mW

*1 Applicable to input terminals other than analog terminals

*2 Applicable to output terminals other than analog terminals

4. AC Characteristics (Condition: Under Recommended Operating Conditions)

Items	Symbol	Condition	Min.	Typ.	Max.	Unit
XI Clock Frequency Duty	Xin Xduty		40	2.822 50	60	MHz %
SCK,SI,CSN Set up time Hold Time	Tset Thold		40 40	- -	- -	ns ns
BCLK,SYNCRN,DIN,DOUT Set up time Hold time Output Delay time	Tset Thold Td		40 40 -	- - -	- - 40	ns ns ns

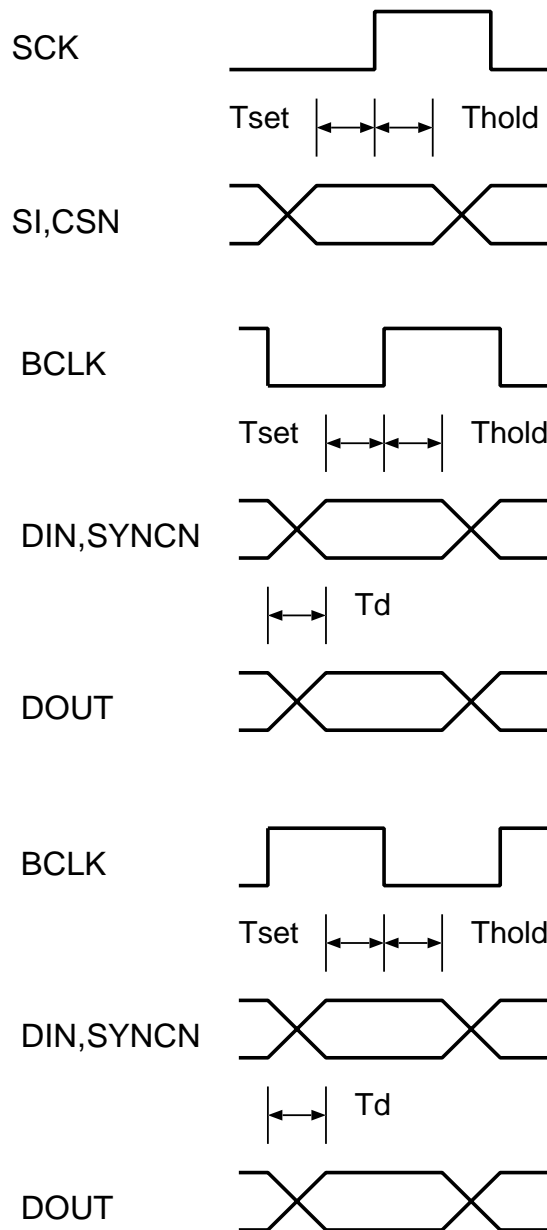

■ Design Example

The figure below shows basic design example that uses YSS901.

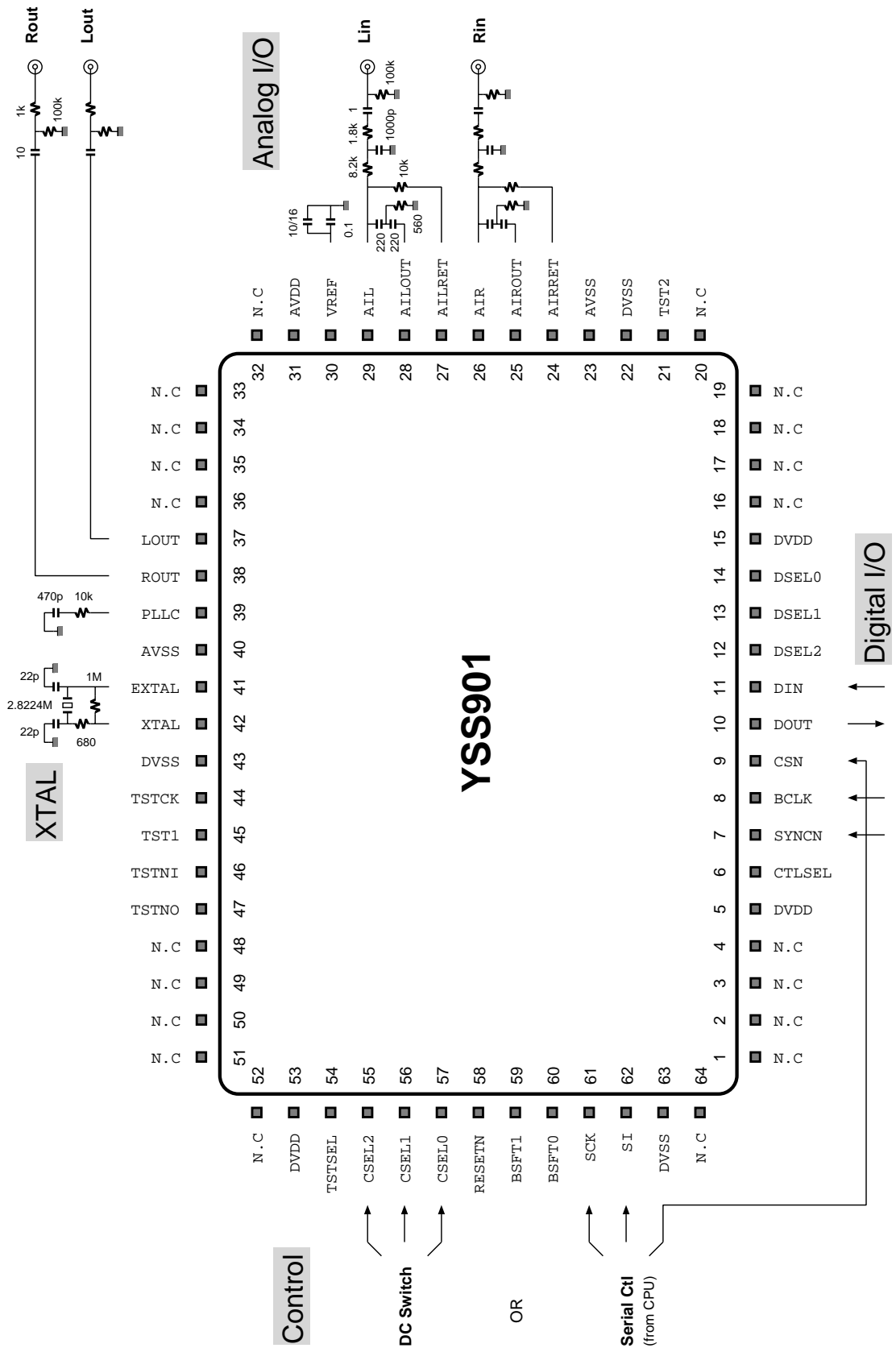

External Dimensions

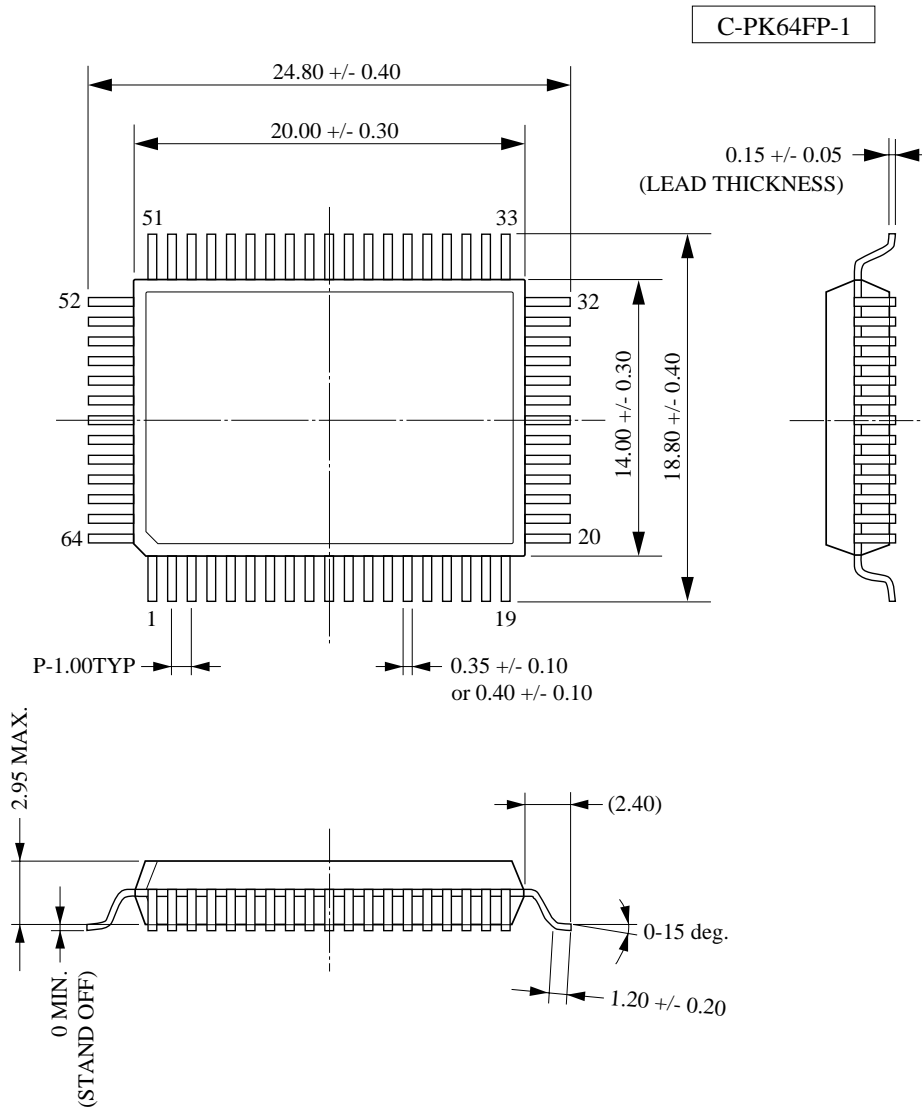

(UNIT) : mm (millimeters)

The figure in the parenthesis () should be used as a reference. Plastic body dimensions do not include burr of resin. UNIT: mm

Memo

IMPORTANT NOTICE

1. Yamaha reserves the right to make changes to its Products and to this document without notice. The information contained in this document has been carefully checked and is believed to be reliable. However, Yamaha assumes no responsibilities for inaccuracies and makes no commitment to update or to keep current the information contained in this document.
2. These Yamaha Products are designed only for commercial and normal industrial applications, and are not suitable for other uses, such as medical life support equipment, nuclear facilities, critical care equipment or any other application the failure of which could lead to death, personal injury or environmental or property damage. Use of the Products in any such application is at the customer's sole risk and expense.
3. Yamaha assumes no liability for incidental, consequential, or special damages or injury that may result from misapplication or improper use or operation of the Products.
4. Yamaha makes no warranty or representation that the Products are subject to intellectual property license from Yamaha or any third party, and Yamaha makes no warranty excludes any liability to the Customer or any third party arising from or related to the Products' infringement of any third party's intellectual property rights, including the patent, copyright, trademark or trade secret rights of any third party.
5. Examples of use described herein are merely to indicate the characteristics and performance of Yamaha products. Yamaha assumes no responsibility for any intellectual property claims or other problems that may result from applications based on the examples described herein. Yamaha makes no warranty with respect to the products, express or implied, including, but not limited to the warranties of merchantability, fitness for a particular use and title.

The specifications of this product are subject to improvement changes without prior notice.

AGENCY

YAMAHA CORPORATION

Address inquiries to:
Semiconductor Sales & Marketing Department

- **Head Office** 203, Matsunokijima, Toyooka-mura
Iwata-gun, Shizuoka-ken, 438-0192
Electronic Equipment Business section
Tel. 81-539-62-4918 Fax. 81-539-62-5054
- **Tokyo Office** 2-17-11, Takanawa, Minato-ku,
Tokyo, 108-8568
Tel. 81-3-5488-5431 Fax. 81-3-5488-5088
- **Osaka Office** Namba Tsujimoto Nissei Bldg, 4F
1-13-17, Namba Naka, Naniwa-ku,
Osaka City, Osaka, 556-0011
Tel. 81-6-6633-3690 Fax. 81-6-6633-3691
- **U.S.A. Office** YAMAHA Systems Technology.
100 Century Center Court, San Jose, CA95112
Tel. 1-408-467-2300 Fax. 1-408-437-8791