



SIDE VIEW IRMS 6118

TOP VIEW IRMT6118

115 Kb/s Infrared Data Transceiver

Preliminary

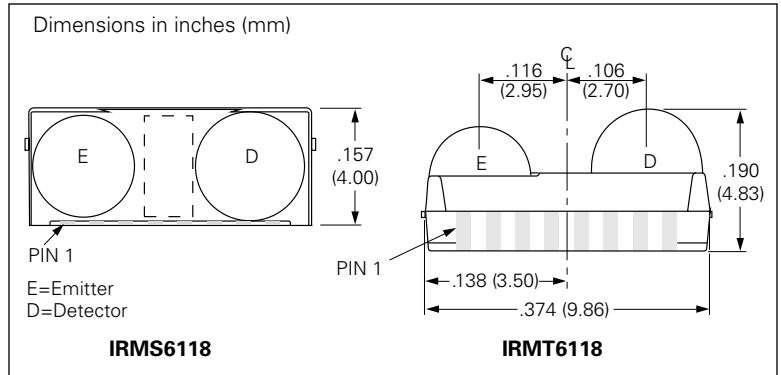
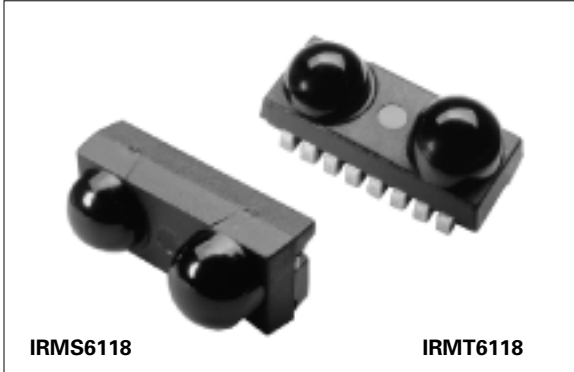

FEATURES

- **Compliant with IrDA Specification**
- **Data Rates 9.6 Kb/s to 115 Kb/s**
- **High Immunity to Fluorescent light-noise**
- **Very High EMI Immunity, Eliminates the Need for Metal Shielding**
- **High DC Ambient Rejection**
- **Wide Range of Supply Voltage 2.4 to 5.0 V**
- **Standby Current 100 μ A Typical**
- **Excellent Power Supply Noise Rejection**
- **Tri-State Receiver Output and TxD Disable**
- **AC Coupled Transmit Input: Provides Integrated Protection for Eye Safety**
- **Independent LED Supply, Anode Pin Can Take**
 - up to 9.0 V DC when not Transmitting and
 - up to 4.0 V above V_{CC} when Transmitting
- **Receiver Latency Less than 100 μ s**
- **Slimline Package:**
 - H 4.0 mm x D 4.8 mm x L 9.8 mm**

DESCRIPTION

With state of the art submicron BiCMOS circuitry, coupled with Infineon optoelectronic expertise, the IRMS6118 and IRMT6118 outperforms its closest rival. The transmit input is AC coupled, limiting transmit pulse duration to 70 μ s, preventing transmitter damage and continuous LED output.

Absolute Maximum Ratings, $T_A=25^\circ\text{C}$ (except where noted)

Supply Voltage Range, all states, V_{CC} -0.5 to +7.0 V
 LED Anode Voltage, V_{LEDA}
 $V_{CC}=0$ to 5.5 V, not transmitting -0.5 to +9.0 V
 LED Anode Voltage, V_{LEDA}
 $V_{CC}=2.4$ to 5.5 V, transmitting -0.5 to $V_{CC} + 4.0$ V
 Input Current I_{CC}
 $V_{CC}=5.0$ V, $TxD=V_{CC}$, transmit 20 mA
 Output Rx/D Current 20 mA
 Storage Temperature, T_S -40 to +100 $^\circ\text{C}$
 Operating Temperature, T_O -25 to +85 $^\circ\text{C}$
 Lead Solder Temperature, Maximum 230 $^\circ\text{C}$ <10 s
 IC Junction Temperature, T_J 125 $^\circ\text{C}$
 Average IR LED Current, I_{LED} 100 mA
 Repetitive Pulsed IR LED Current,
 <10 μ s, t_{on} <20%, LED Anode=3.3 V, $I_{LED(RP)}$ 600 mA
 Input Voltage: Tx/D -0.5 to $V_{CC} + 0.5$ V
 Rx/D Voltage -0.5 to $V_{CC} + 0.5$ V

Table 1. Pin Functions

Pin no.	Function	Pin no.	Function
1	IR LEDA	5	SD
2	IR LEDC	6	V_{CC}
3	TxD	7	GND
4	RxD	8	GND

Figure 1. Block Diagram

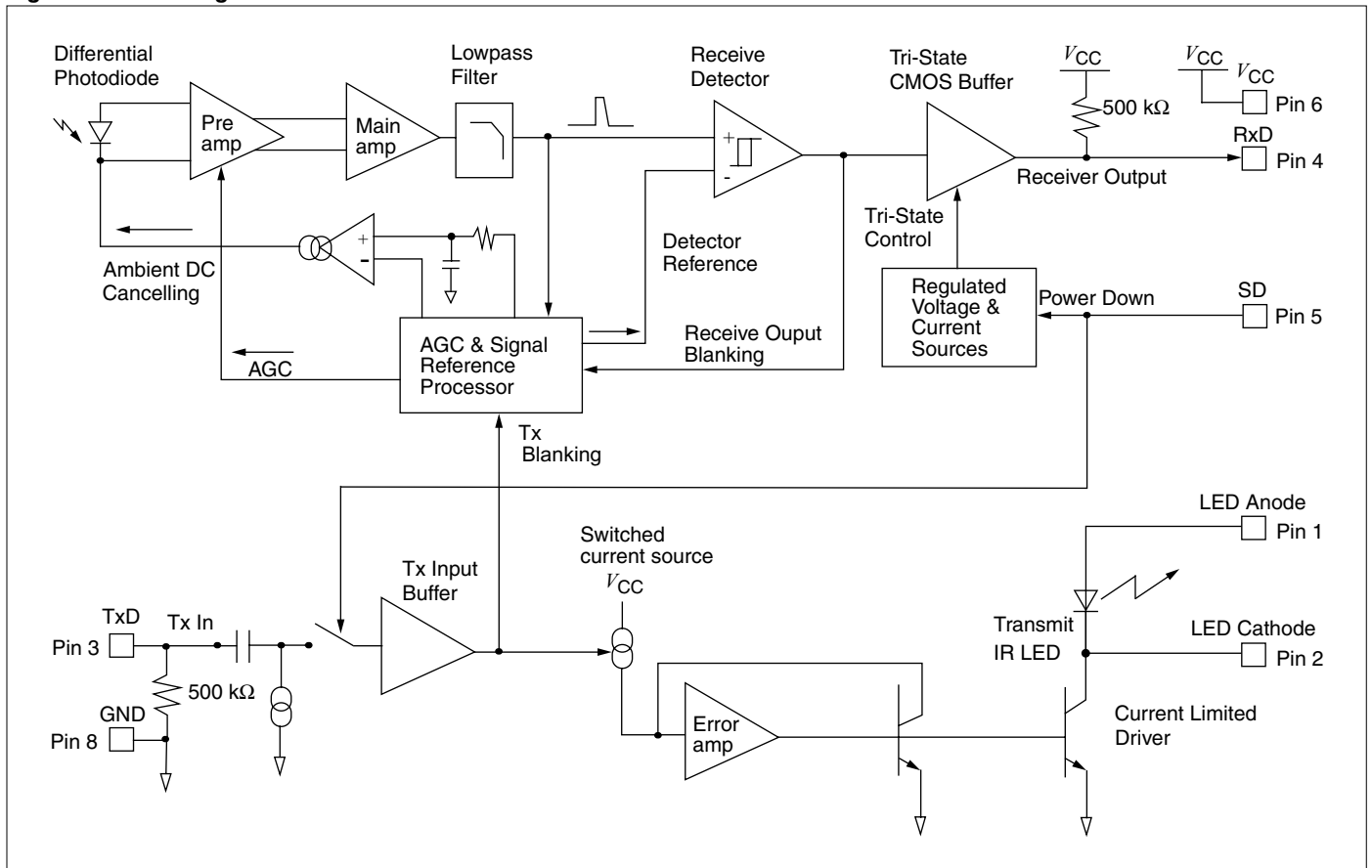

Theory of operation

The IRMS6118/IRMT6118 Slimline—Infrared Data Transceiver consists of a detector photodiode, an IR LED transmitter, an IC containing ambient light suppressor, and Automatic Gain control circuitry (AGC).

The ambient light suppressor can cancel up to 10 mW/cm² (typical) at 5.0 V of DC ambient signal. This will typically allow operation in all but direct sunlight.

The AGC in the IC is to keep the system output constant by varying the gain to accommodate a wide range of input signals. It also provides noise immunity in the high noise ambient environment.

For normal operation of the transmit and receiver modes, the Shut Down (SD) pin should be held low. It is recommended that this pin be connected to GND if Shut Down (SD) mode is not used.

In receive mode, the receiver output (RxD) which normally stays high, will go low for duration of the receive pulses. It is a push-pull CMOS driver capable of driving a standard CMOS or TTL load. No external pull-up or pull-down resistor is required.

In transmit mode, by asserting the TxD pin above 1/2 V_{CC} will turn on IR LED transmitter. At the LED Anode (pin 1) connect this pin to V_{CC} or unregulated power supply (not to exceed V_{CC} + 4.0 V), through a resistor to set the proper LED current to reduce the thermal dissipation and to lower LED current.

Table 2. Slimline IRMS6118/IRMT6118 Truth Table

Inputs				Outputs	
V _{CC}	SD	TxD	Detector	RxD	LED
2.4 V to 5.0 V	High	X=don't care state	X=don't care state	500 kΩ pull-up	Off
2.4 V to 5.0 V	Low	High		Undefined	On
		Low	<0.4 μW/cm ²	High	Off
			<4.0 μW/cm ²	Low	

Electrical Characteristics

Table 3. Basic Operating Parameters, T_A=25°C (except where noted)

Parameter	Symbol	Min.	Typ.	Max.	Unit	Conditions
Supported Data Rate	—	9.6	—	115	Kb/s	1.63 μs or 3/16 clock period
Power Supply Voltage	V _{CC}	2.4	—	5.0	V	-25°C to +85°C, V _{CC} to V _{SS}
Maximum LED Anode Voltage	V _{LEDA}	—	—	V _{CC} +4	V	V _{CC} =2.4 V to 5.0 V
I _{CC} Shut Down Current (Note 1)	I _{CC1}	—	0.01	1.0	μA	SD=V _{CC} , V _{CC} =2.4 V to 5.0 V
I _{CC} Standby Current (Avg.)	I _{CC1}	65	110	—	μA	no signal, V _{CC} =2.7 V to 3.3 V
I _{CC} Receiving Current (Avg.)	I _{CC2}	—	120	—	μA	V _{CC} =2.7 V to 3.3 V
I _{CC} Transmitting Current (Avg.)	I _{CC3}	—	1.7	2.5	mA	V _{CC} =2.7 V to 3.3 V, No LED resistor, V _{LED} =3.0 V DC

Table 4. I/O Parameters

Parameter	Symbol	Min.	Typ.	Max.	Unit	Conditions
TxD, SD Input Capacitance	—	—	5.0	—	pF	V _{CC} =2.4 V to 5.0 V
TxD Resistance	—	350	500	650	kΩ	TxD=V _{CC} , V _{CC} =2.4 V to 5.0 V
TxD, SD Input Threshold (Note 1)	—	0.8	1.4	2.0	V	V _{CC} =2.4 V to 5.0 V
SD to RxD Tri-State	—	—	35	100	ns	V _{CC} =2.4 V to 5.0 V
SD to RxD Enable	—	—	90	200	ns	V _{CC} =2.4 V to 5.0 V
RxD Output High	V _{IH}	—	4.3	—	V	V _{CC} =5.0 V, I _{OH} =8 mA
RxD Output High	V _{IH}	—	1.7	—	V	V _{CC} =2.4 V, I _{OH} =3 mA
RxD Output Low	V _{IL}	—	0.7	—	V	V _{CC} =5.0 V, I _{OL} =8 mA
RxD Output Low	V _{IL}	—	0.3	—	V	V _{CC} =2.4 V, I _{OL} =3.0 mA
RxD Short Circuit	—	—	25	—	mA	V _{CC} =5.0 V, RxD=0, RxD=V _{CC}
RxD Short Circuit	—	—	4	—	mA	V _{CC} =2.4 V, RxD=0, RxD=V _{CC}
RxD to V _{CC} Tri-State Impedance	—	—	500	—	kΩ	V _{CC} =2.4 V to 5.0 V, between RxD to V _{CC}
RxD Rise Time	t _r	—	30	—	ns	V _{CC} =5.0 V, Load=15 pF
RxD Rise Time	t _r	—	40	—	ns	V _{CC} =2.4 V, Load=15 pF

Table 5. Receiver Parameters, T_A=25°C (except where noted)

Parameter	Symbol	Min.	Typ.	Max.	Unit	Conditions
Maximum Data Rate	—	9.6	—	115.2	Kb/s	1.63 μs with E _e =4.0 μW/cm ² to 500 mW/cm ²
Receive 1/2 Angle	—	15	20	30	degree	IrDA <i>Physical Layer</i> specification
Minimum Signal Detect Irradiance	E _{IHmin}	—	2.0	4.0	μW/cm ²	Bit error rate=10 ⁻⁸ , 1.63 μs pulse
Maximum Signal Detect Irradiance	E _{Emax}	—	500	—	mW/cm ²	Bit error rate=10 ⁻⁸ , 1.63 μs pulse
Maximum Signal Irradiance No detect	—	—	—	0.3	μW/cm ²	<0.1 pulse per second detect, 1.63 μs
Maximum DC Ambient Irradiance, 5.0 V (Note 5)	—	—	10	—	mW/cm ²	V _{CC} =5.0 V
Maximum DC Ambient Irradiance, 2.4 V (Note 5)	—	—	2.5	—	mW/cm ²	V _{CC} =2.4 V
Transmit Receiver Latency (Note 2)	t _L	—	50	100	μs	0 to 3 mW/cm ² DC ambient input
RxD Suppression Duration (Note 6)	—	—	50	100	μs	Following end of TxD pulse
Powerup Receiver Latency	—	—	50	100	μs	0 to 3 mW/cm ² DC ambient input
Output Pulse Width at RxD	—	1.0	1.63	3.0	μs	1.63 μs, 4 μW/cm ² to 500 mW/cm ² input.

Table 5. Receiver Parameters (continued)

Parameter	Symbol	Min.	Typ.	Max.	Unit	Conditions
Maximum Output Pulse Width at RxD, (Note 5)	—	—	57	100	μs	200 μs, 500 mW/cm ² , V _{CC} =5.0 V
Small Ripple Power Supply Rejection (Note 4)	—	50	100	—	mV/μs	100 mV _{P-P} triangle wave on V _{CC}
Large Ripple Power Supply Rejection (Note 4)	—	100	200	—	mV/ms	1.0 V _{P-P} triangle wave on V _{CC}

Table 6. Transmitter Output

Parameter	Symbol	Min.	Typ.	Max.	Unit	Conditions
Maximum Data Rate	—	9.6	—	115.2	Kb/s	TxD pulse width=1.63 μs
TxD Radiant Intensity (peak)	—	40	70	230	mW/Sr	5.1 Ω LED resistor, 5.0 V _{LED} supply
TxD Radiant Intensity (peak)	—	—	70	230	mW/Sr	LEDA=2.4 V, no current limiting LED resistor
TxD 1/2 Angle	—	15	20	30	degree	IrDA <i>Physical Layer</i> specification
TxD Peak Wavelength	λ _{peak}	850	870	900	nm	I _F =20 mA
I _{LED} Pulse Width	—	1.51	1.61	1.71	μs	TxD=1.63 μs, V _{CC} =5.0 V
Optical Rise and Fall Time	t _r , t _f	—	90	—	ns	V _{LED} =2.7 V
Pulse Width Limit	—	35	70	140	μs	TxD pulse>200 μs, 5.0 V pulse, V _{CC} =5.0 V
I _{LED} Limit	—	250	350	400	mA	TxD=V _{CC} , LED anode=3.3 V, V _{CC} =5.0 V

Note 1:

For Shut Down (SD) current to fall below 1 μA requires driving Shut Down (SD) to within 0.5 V of V_{CC} to ensure cutoff of the PMOS transistor of the input CMOS totem pole. In most applications this is not an issue if Shut Down (SD) is driven from a CMOS driver supplied from the same voltage supply

Note 2:

“Near-Far Receiver Latency” is the time required for the AGC and ambient correction circuits to return to maximum sensitivity (Far) following reception of a maximum (Near) signal or a change in ambient. “Transmit Receiver Latency” is commonly called “Receiver Latency” or “Transmitter Turnaround Time.”

Note 3:

“AGC Decay Rate” is the rate at which the receiver gain increases following the cessation of signal input.

Note 4:

The receiver V_{CC} power supply rejection is significantly better for small ripple of less than 100 mV_{P-P} than for larger values. For ripple of more than 100 mV_{P-P}, internal circuits can maintain operating headroom provided that the slew rate is significantly slower. Typically, these specifications allow operation without an external filter from either switching supplies with less than 50 mV_{P-P} ripple or unregulated supplies with less than 1 V_{P-P} of 120 Hz ripple.

Note 5:

If the low going RxD pulse width exceeds 100 μs, then the maximum DC ambient irradiance has been exceeded.

Note 6:

RxD is suppressed (forced high) while (TxD) transmit pulse is active and for the indicated period following the end of the TxD pulse.

Figure 2. Timing Diagrams

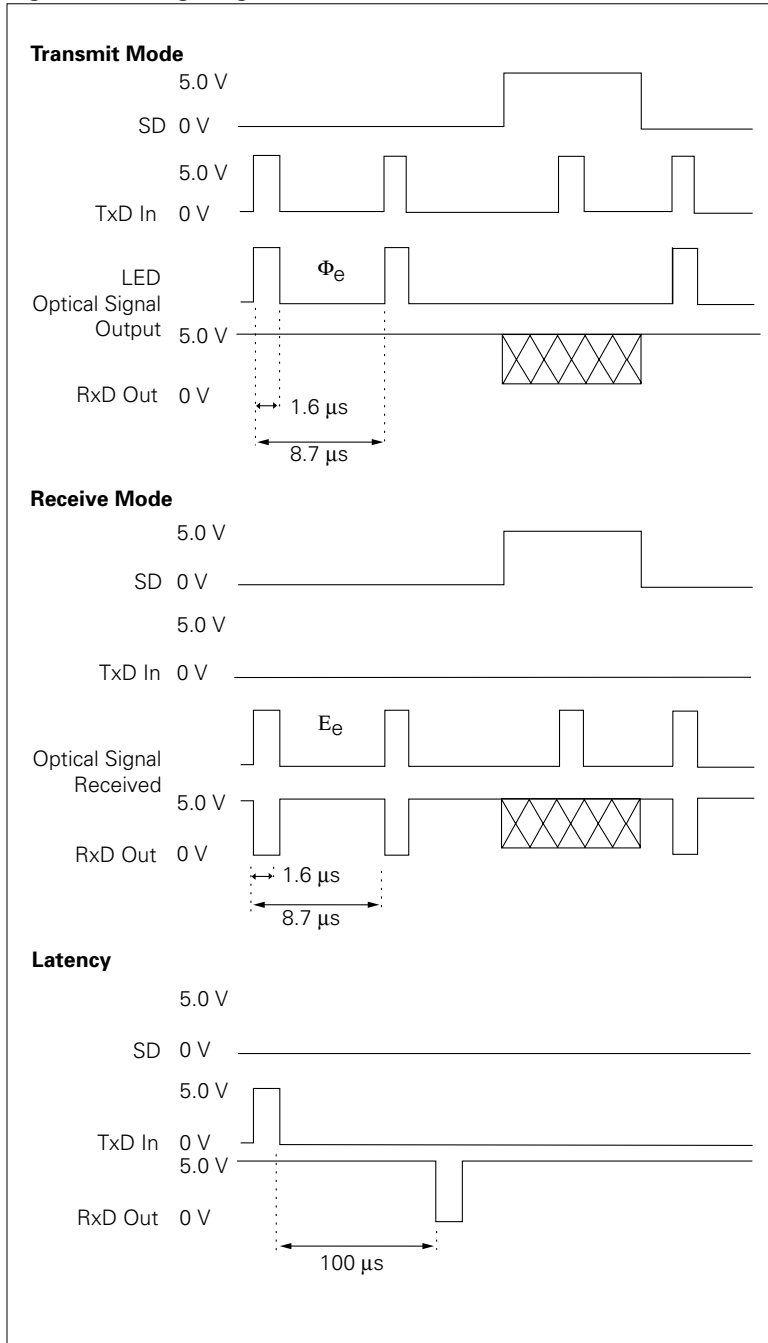

Figure 3. Input Schematics

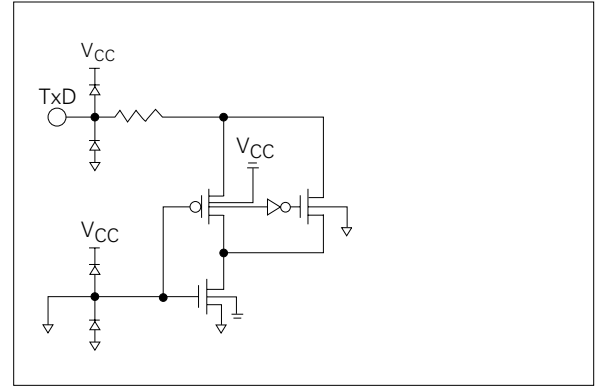

Figure 4. Output Schematics

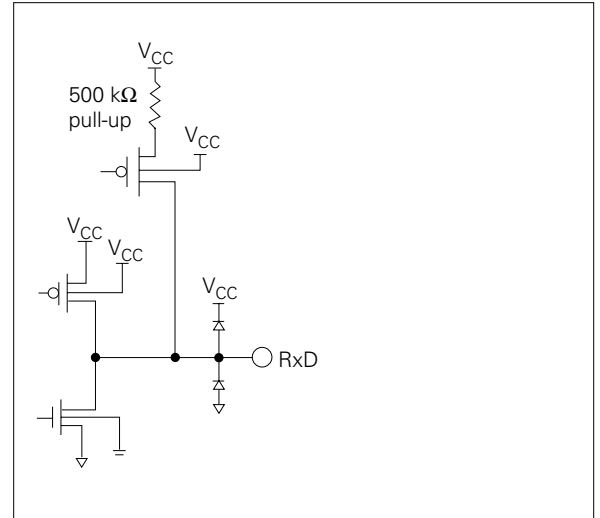
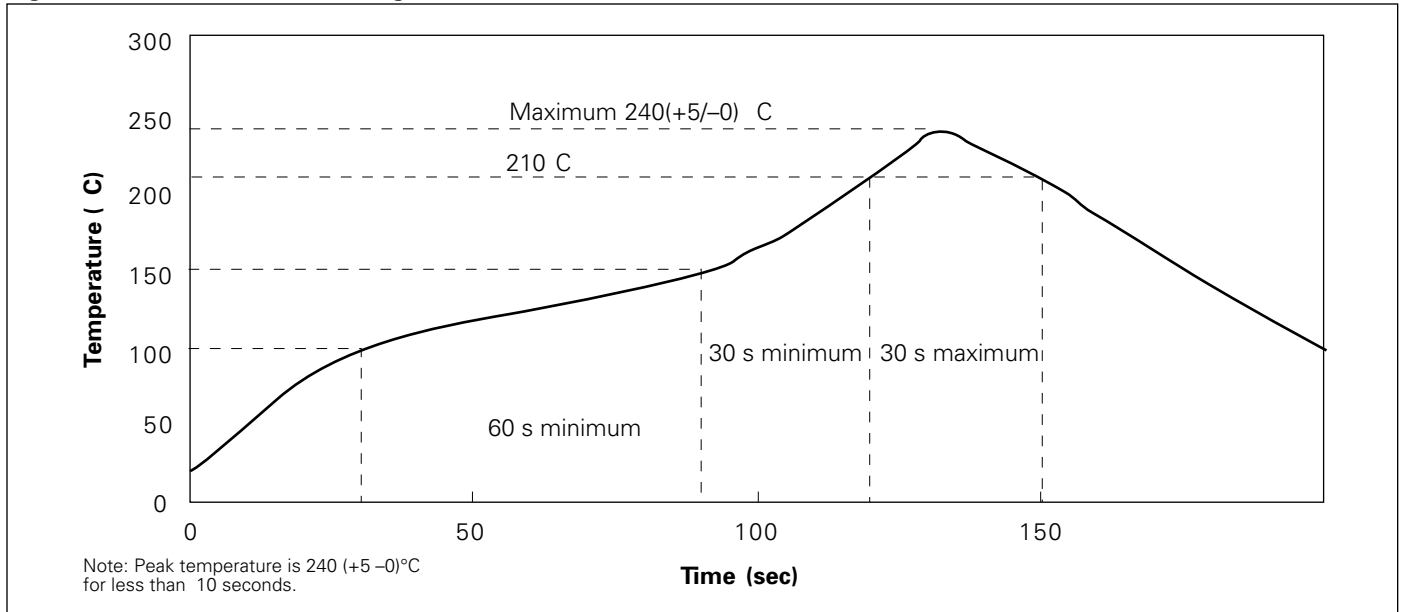

Figure 5. Infrared Reflow Soldering Profile



Interface Diagrams

Figure 6. Super I/O (PC87108AVJE) to IRMS6118/IRMT6118

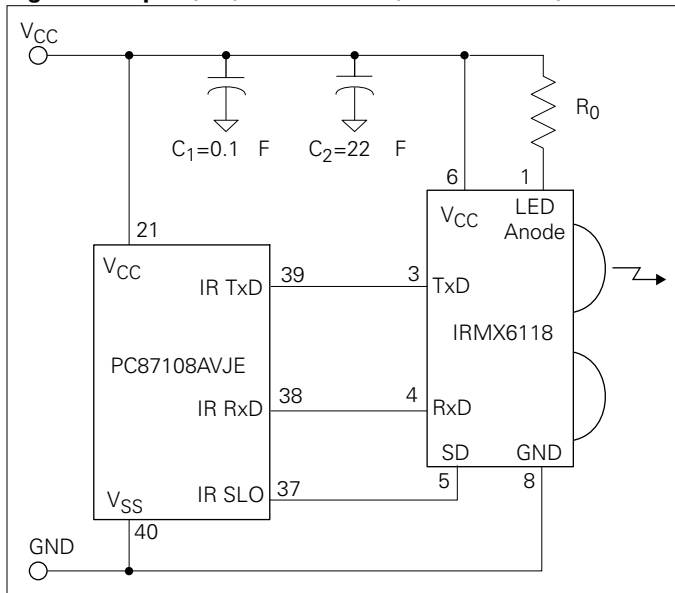

Figure 7. With independent V_{LED} supply

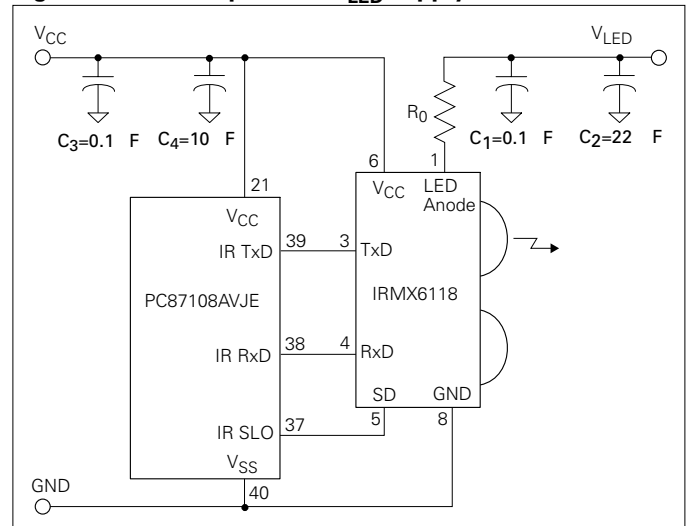

Table 7. Recommended External Component

Parameter	Values							Unit
V _{LED} power supply	2.4	2.7	3.0	3.5	4.0	4.5	5.0	V
Resistor	0	0	0	1.5	3.9	5.1	6.8	Ω

Ordering Information

Part Number	Description	PCB Mounting Orientation
IRMS6118	Integrated Transceiver —Side View	Packaged in Component Carrier Reel (1000/reel) for Side View Mounting on PCB
IRMT6118	Integrated Transceiver —Top View	Packaged in Component Carrier Reel (1000/reel) for Top View Mounting on PCB

Tape Leader and Trailer is 400 mm minimum.

Figure 9. Reel Dimensions in Inches (mm)

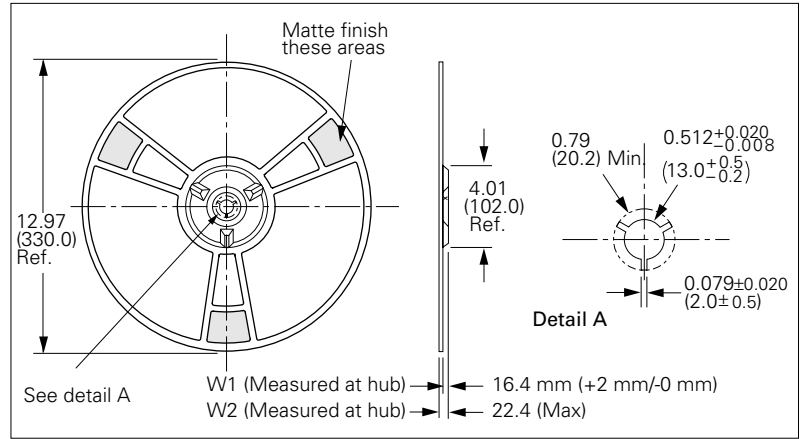

Figure 8. Tape Dimensions in Inches (mm)

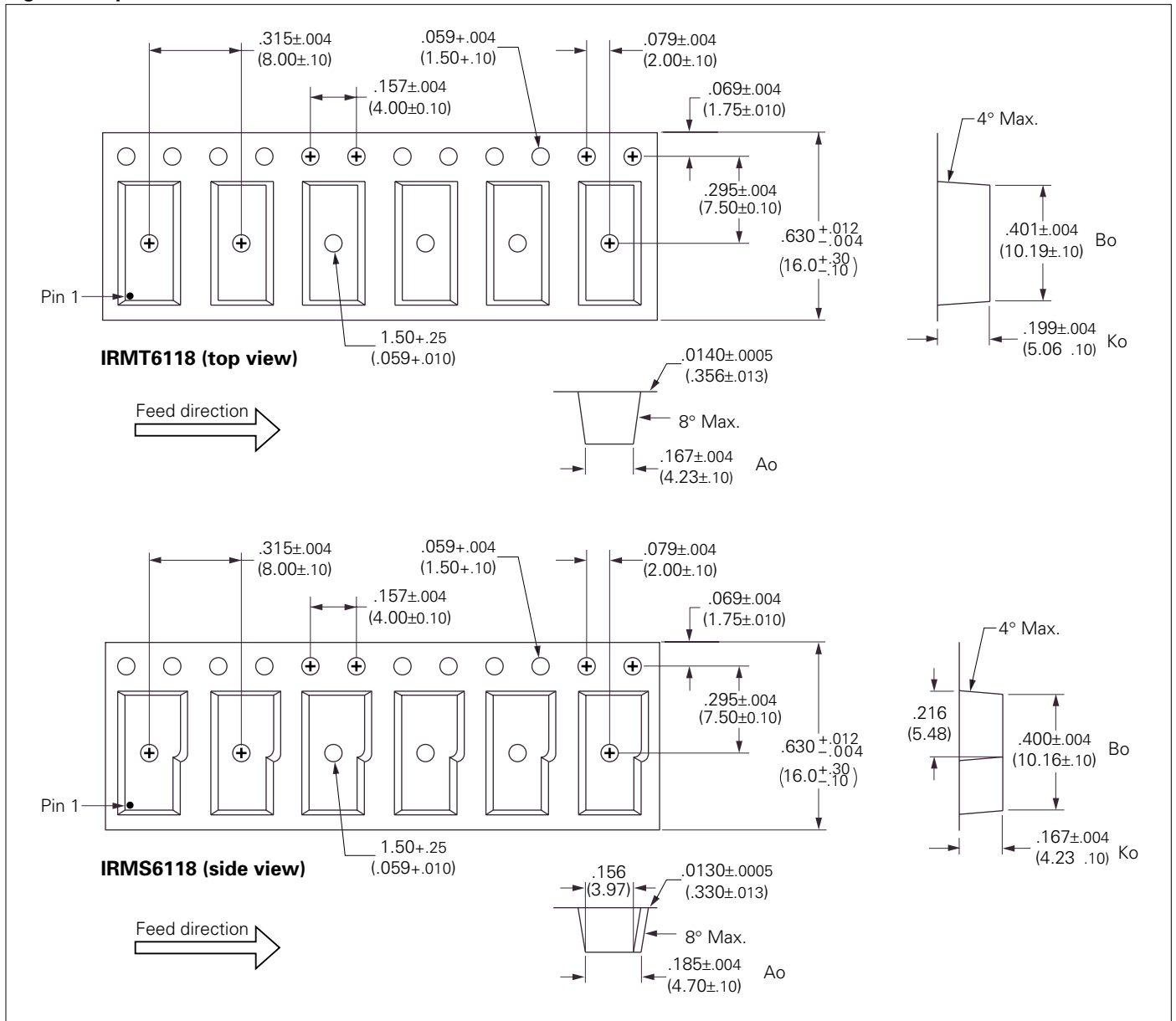
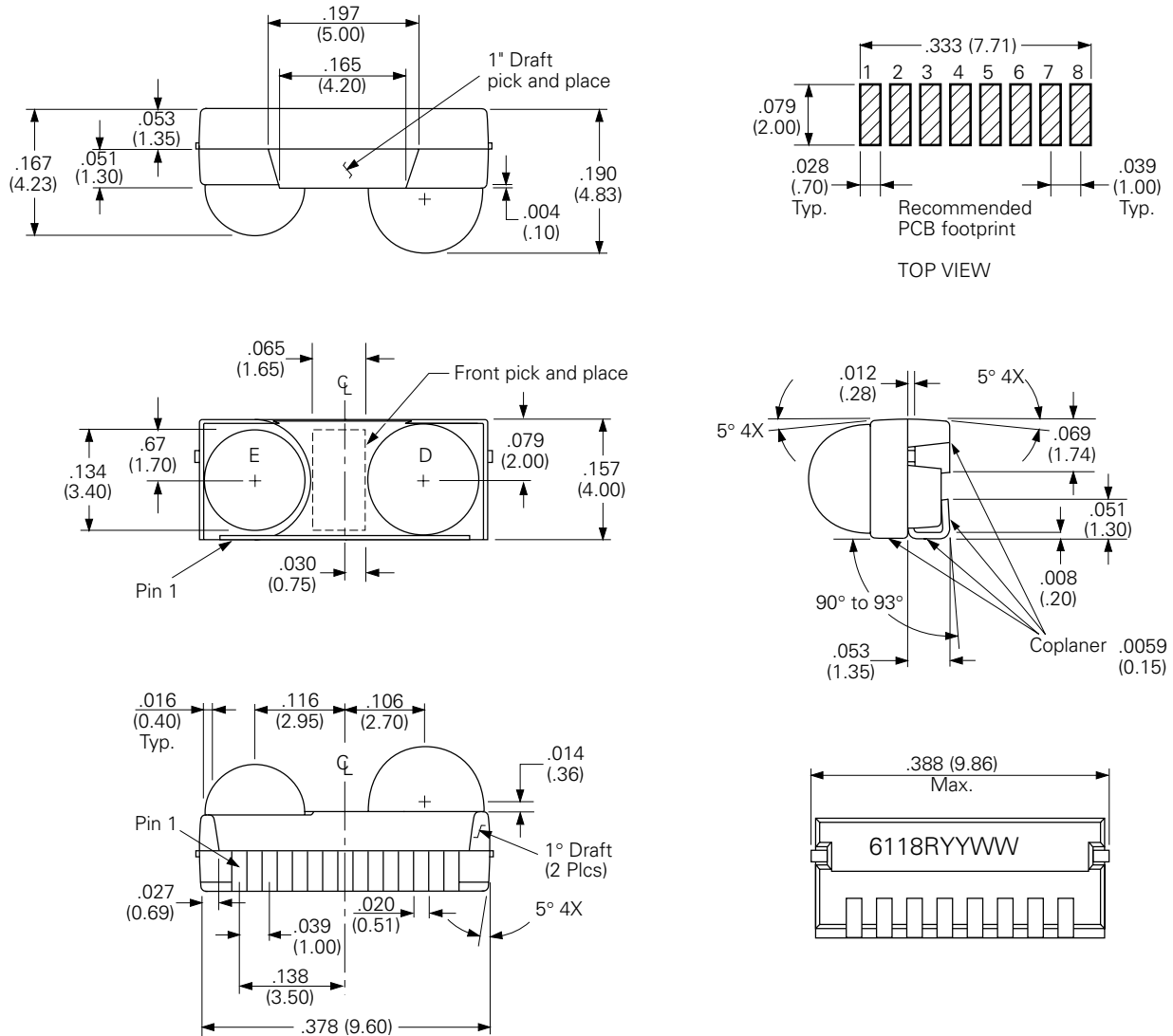

Figure 10. IRMS6118/IRMT6118 Detail Drawings With Optional Side View or Top View Mounting

Dimensions in inches (mm)—All dimensions have tolerances of ± 0.004 " (± 0.1 mm)



© Infineon Technologies, Corp., Optoelectronic Division
(formerly Siemens Microelectronics, Inc.)

Printed in the United States of America.

All rights reserved.

The information provided is believed to be accurate and reliable.

Infineon reserves the right to make changes to the product described without notice. No liability is assumed as a result of its use nor for any infringement of the rights of others.

This document may contain preliminary information and is subject to change by Infineon without notice. Some of the parametric data expressed in this preliminary data sheet is considered to be functional by design. Infineon assumes no responsibility or liability for any use of the information contained herein. Nothing in this document shall operate as an express or implied license or indemnity under the intellectual property rights of Infineon or third parties.

The products described in this document are not intended for use in implantation or other direct life support applications where malfunction may result in the direct physical harm or injury to persons.

NO WARRANTIES OF ANY KIND, INCLUDING, BUT NOT LIMITED TO, THE IMPLIED WARRANTIES OF MERCHANTABILITY OF FITNESS FOR A PARTICULAR PURPOSE, ARE OFFERED IN THIS DOCUMENT.

