

TOSHIBA MOS MEMORY PRODUCTS

TMM2063AP-70, TMM2063AP-10 TMM2063AP-12

DESCRIPTION

The TMM2063AP is a 65,536 bits high speed and low power static random access memory organized as 8,192 words by 8 bits and operates from a single 5V supply. Toshiba's high performance device technology provides both high speed and low power features with a maximum access time of 70ns/100ns/120ns and maximum operating current of 80mA. When CS1 is logical high or CS2 is a logical low, the device is placed in a low power standby mode in which maximum standby current is 10mA. Thus the TMM2063AP is most suitable for use in microcomputer peripheral memory where the low power applications are required, moreover, suitable for use in high density assembly as 0.3 inch width package is use for. The TMM2063AP is fabricated with ion implanted N channel silicon gate MOS technology for high performance and high reliability.

FEATURES

• Access Time and Current

Parameter Part Number	Access Time (Max.)	Operating Current (Max.)	Standby Current (Max.)
TMM2063AP-70	70ns	80mA	10mA
TMM2063AP-10	100ns	80mA	10mA
TMM2063AP-12	120ns	80mA	10mA

• High Density Assembly Capability: 0.3 inch width package (28 pins plastic DIP)

- Single 5V Power Supply
- Fully Static Operation
- Power Down Feature: CS1, CS2
- Output Buffer Control: OE
- Three State Outputs
- All Inputs and Outputs: Directly TTL Compatible
- Inputs Protected: All inputs have protection against static charge.

PIN CONNECTION

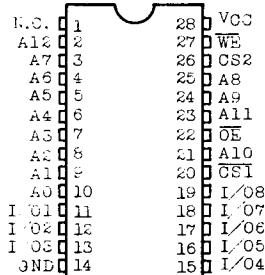

PIN NAMES

SYMBOL	NAME
A0 ~ A4	Column Address Inputs
A5 ~ A12	Row Address Inputs
CS1, CS2	Chip Select Inputs
WE	Write Enable Input
I/O1 ~ I/O8	Data Input/Output
OE	Output Enable Input
VCC	Power (+5V)
GND	Ground
N.C.	No Connection

BLOCK DIAGRAM

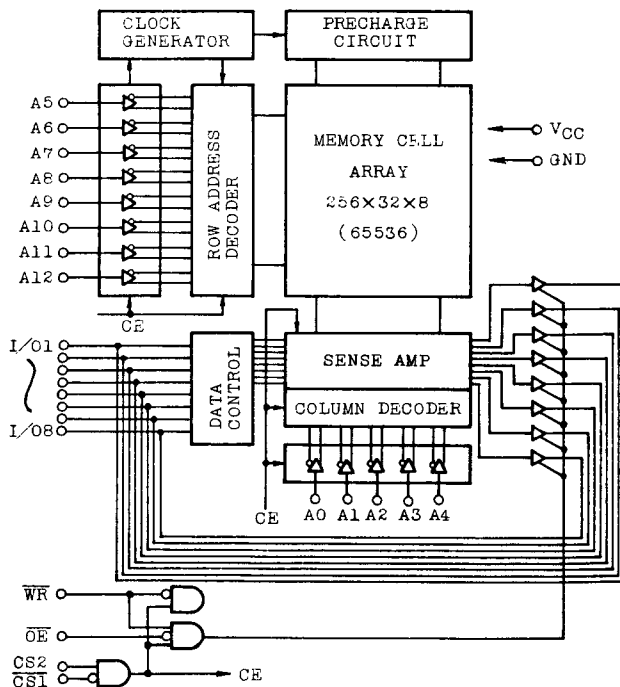

TMM2063AP-70, TMM2063AP-10 TMM2063AP-12

MAXIMUM RATINGS

SYMBOL	ITEM	RATING	UNIT
V _{CC}	Power Supply Voltage	-0.5 ~ 7.0	V
V _{IN} , V _{OUT}	Input Output Voltage	-0.5 ^{*1} ~ 7.0	V
T _{opr.}	Operating Temperature	0 ~ 70	°C
T _{stg.}	Storage Temperature	-55 ~ 150	°C
T _{solder}	Soldering Temperature . Time	260 . 10	°C . sec
P _D	Power Dissipation (Ta=70°C)	0.8	W

*1 -3.0V at pulse width 50ns

D.C. RECOMMENDED OPERATING CONDITION (Ta=0 ~ 70°C)

SYMBOL	PARAMETER	MIN.	TYP.	MAX.	UNIT
V _{IH}	Input High Voltage	2.0	-	V _{CC} +1.0	V
V _{IL}	Input Low Voltage	-0.5*2	-	0.8	V
V _{CC}	Supply Voltage	4.5	5.0	5.5	V

*2 -3.0V at pulse width 50ns

D.C. CHARACTERISTICS (Ta=0 ~ 70°C, V_{CC}=5.0V±10%)

SYMBOL	PARAMETER	CONDITIONS	MIN.	TYP.	MAX.	UNIT
I _{IL}	Input Leakage Current	V _{IN} =0V ~ 5.5V	-10	-	10	μA
V _{OH}	Output High Voltage	I _{OUT} =-1.0mA	2.4	-	-	V
V _{OL}	Output Low Voltage	I _{OUT} =4.0mA	-	-	0.4	V
I _{LO}	Output Leakage Current	CS ₁ =V _{IH} or CS ₂ =V _{IL} or WE=V _{IL} or OE=V _{IH} , V _{OUT} =0V ~ 5.5V	-10	-	10	μA
I _{SBP}	Peak Power-on Current	CS ₁ =V _{CC} , CS ₂ =0V, I _{OUT} =0mA	-	-	20	mA
I _{SB}	Standby Current	CS ₁ =V _{IH} or CS ₂ =V _{IL} , I _{OUT} =0mA	-	-	10	mA
I _{CC}	Operating Current	CS ₁ =V _{IL} , CS ₂ =V _{IH} , I _{OUT} =0mA	-	-	80	mA

CAPACITANCE * (Ta=25°C, f=1.0 MHz)

SYMBOL	PARAMETER	CONDITIONS	MAX.	UNIT
C _{IN}	Input Capacitance	V _{IN} =0V	6	pF
C _{OUT}	Output Capacitance	V _{IN} =0V	10	

* Note: This parameter is periodically sampled and is not 100% tested.

TMM2063AP-70, TMM2063AP-10 TMM2063AP-12

A.C. CHARACTERISTICS (Ta=0 ~ 70°C, V_{CC}=5V±10%)

READ CYCLE

SYMBOL	PARAMETER	TMM2063AP-70		TMM2063AP-10		TMM2063AP-12		UNIT
		MIN.	MAX.	MIN.	MAX.	MIN.	MAX.	
t _{RC}	Read Cycle Time	70	-	100	-	120	-	ns
t _{ACC}	Address Access Time	-	70	-	100	-	120	
t _{CO1}	$\overline{CS1}$ Access Time	-	70	-	100	-	120	
t _{CO2}	$\overline{CS2}$ Access Time	-	70	-	100	-	120	
t _{OE}	\overline{OE} Access Time	-	35	-	40	-	50	
t _{OH}	Output Data Hold Time from Address Change	5	-	10	-	10	-	
t _{CLZ}	Output Enable Time from $\overline{CS1}$ or CS2	10	-	10	-	10	-	
t _{CHZ}	Output Disable Time from $\overline{CS1}$ or CS2.	-	30	-	40	-	40	
t _{OLZ}	Output Enable Time from \overline{OE}	5	-	5	-	5	-	
t _{OHZ}	Output Disable Time from \overline{OE}	-	30	-	35	-	35	
t _{PU}	Chip Selection to Power Up Time	0	-	0	-	0	-	
t _{PD}	Chip Deselection to Power Down Time	-	40	-	50	-	60	

WRITE CYCLE

SYMBOL	PARAMETER	TMM2063AP-70		TMM2063AP-10		TMM2063AP-12		UNIT
		MIN.	MAX.	MIN.	MAX.	MIN.	MAX.	
t _{WC}	Write Cycle Time	70	-	100	-	120	-	ns
t _{CW}	Chip Selection to End of Write	60	-	80	-	100	-	
t _{AS}	Address Set Up Time	10	-	10	-	10	-	
t _{WP}	Write Pulse Width	50	-	70	-	85	-	
t _{WR}	Write Recovery Time	0	-	0	-	0	-	
t _{DS}	Data Set Up Time	30	-	40	-	50	-	
t _{DH}	Data Hold Time	0	-	0	-	0	-	
t _{WLZ}	Output Enable Time from \overline{WE}	5	-	5	-	5	-	
t _{WHZ}	Output Disable Time from \overline{WE}	-	25	-	30	-	35	

A.C. TEST CONDITIONS

Input Pulse Levels	V _{IH} =2.2V, V _{IL} =0.6V
Input Rise and Fall Time	5NS
Input and Output Reference Levels	1.5V
Output Load	1 TTL Gate & C _L =100pF

TMM2063AP-70, TMM2063AP-10 TMM2063AP-12

TIMING WAVEFORMS

READ CYCLE (1)

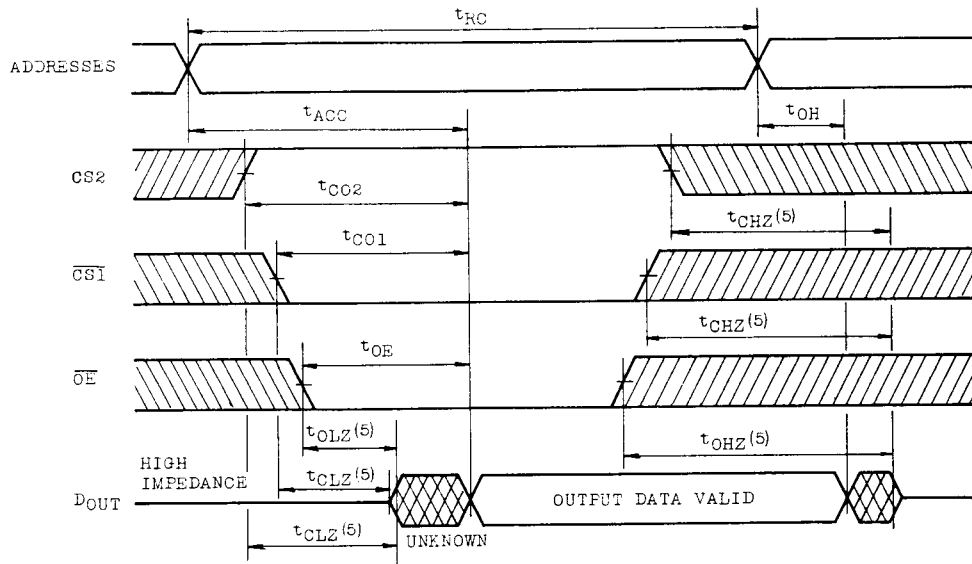

WRITE CYCLE 1 (4) (\overline{WE} Controlled Write)

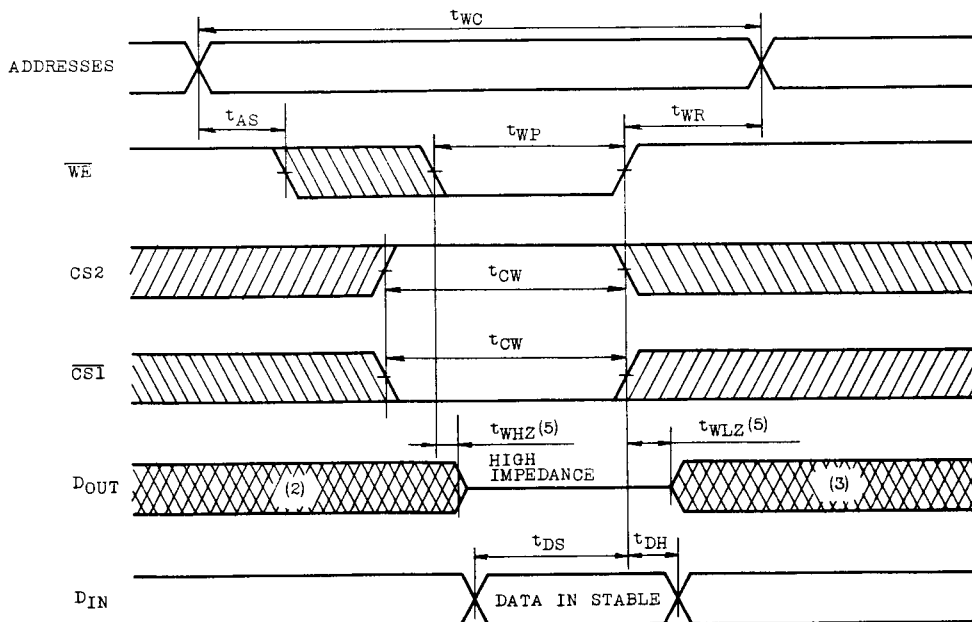

TMM2063AP-70, TMM2063AP-10 TMM2063AP-12

WRITE CYCLE 2 (4) ($\overline{CS1}$ Controlled Write)

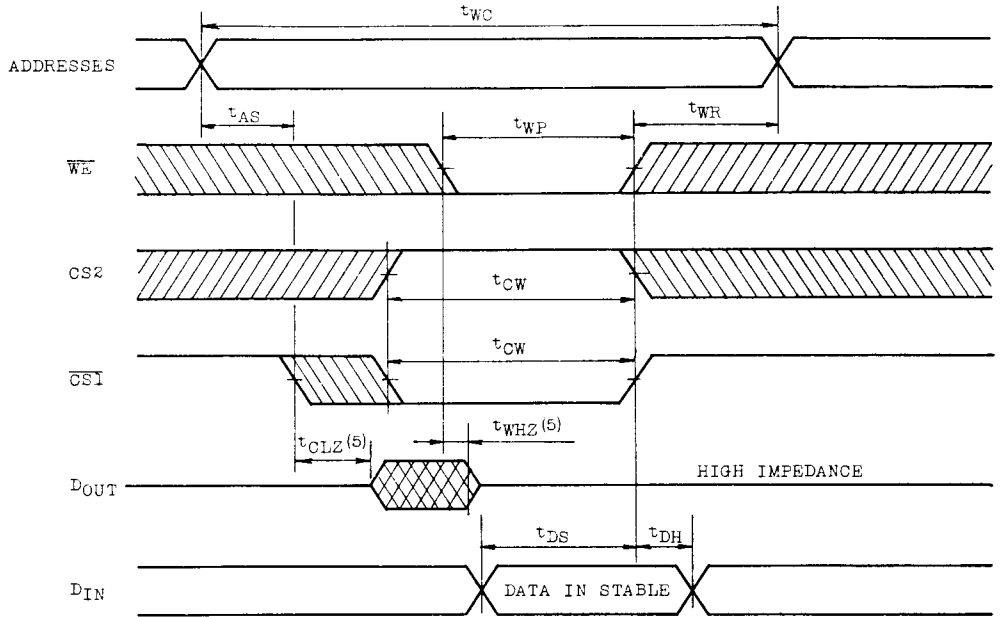

WRITE CYCLE 3 (4) ($CS2$ Controlled Write)

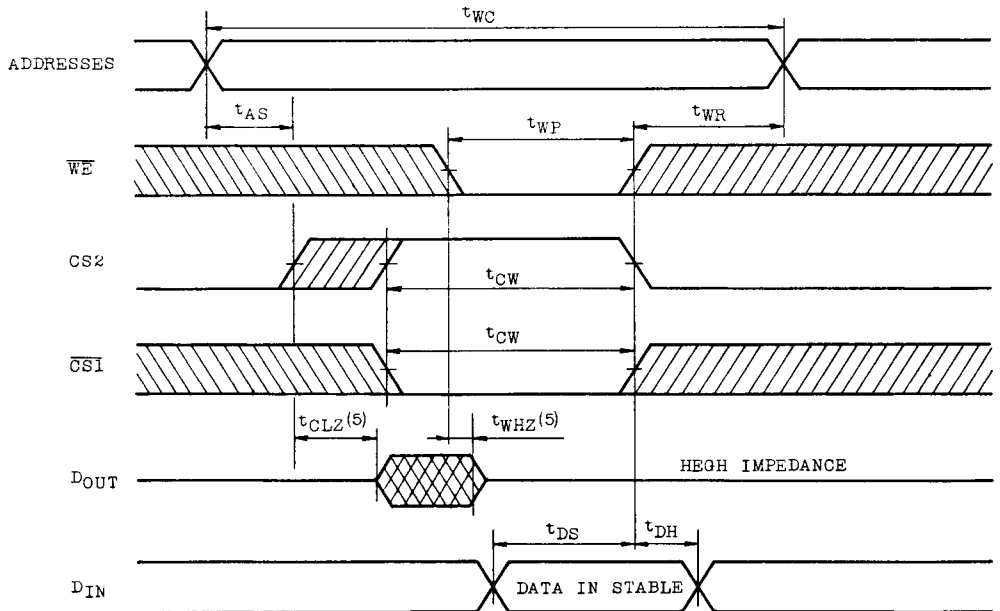

TMM2063AP-70, TMM2063AP-10 TMM2063AP-12

- Note: 1. \overline{WE} is High for Read Cycle.
2. Assuming that $\overline{CE1}$ Low transition or CS2 High transition occurs coincident with or after \overline{WE} Low transition, Outputs remain in a high impedance state.
 3. Assuming that $\overline{CE1}$ High transition or CS2 Low transition occurs coincident with or prior to \overline{WE} High transition, Outputs remain in a high impedance state.
 4. Assuming that \overline{OE} is High for Write Cycle, Outputs are in high impedance state during this period.
 5. These parameters are specified as follows and measured by using the load shown in Fig. 1.

- (A) t_{CLZ} , t_{OLZ} , t_{WLZ} Output Enable Time
 (B) t_{CHZ} , t_{OHZ} , t_{WHZ} Output Disable Time

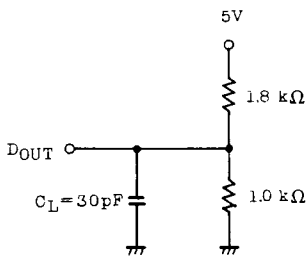
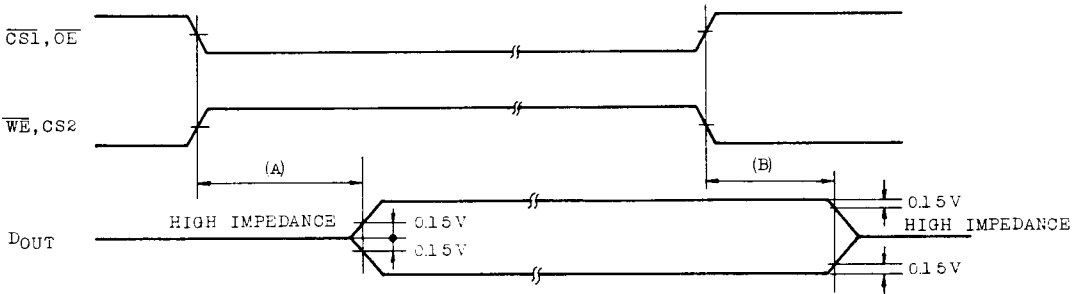
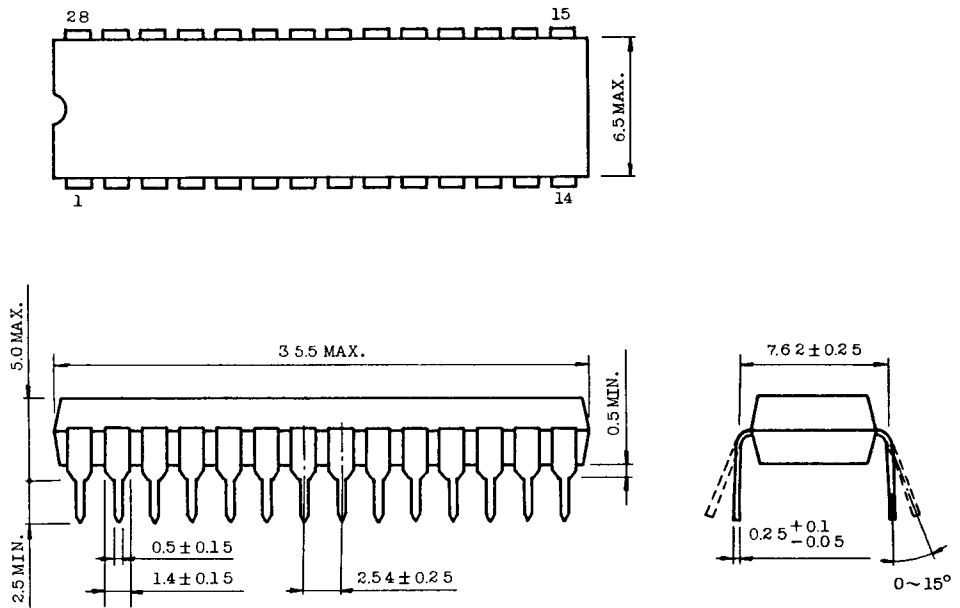

Fig.1 Output load condition for enable disable time measurement.

TMM2063AP-70, TMM2063AP-10 TMM2063AP-12

OUTLINE DRAWINGS

Unit: mm



Note: Each lead pitch is 2.54mm. All leads are located within 0.25mm of their true longitudinal position with respect to No.1 and No.28 leads.