

# MAXIM

## MAX8521 Evaluation Kit

### General Description

The MAX8521 evaluation kit (EV kit) is an assembled and tested PC board that implements a switch-mode driver for a Peltier thermoelectric cooler (TEC) module. The device operates from a single 3V to 5.5V supply and provides a bipolar  $\pm 1.5A$  output to the module.

A potentiometer, DAC, or external source generates a DC temperature set-point voltage. Thermal feedback from the TEC module is compared to the set-point voltage to generate the TEC current control signal. The MAX8521 accurately regulates the TEC current based on this signal. When using the DAC, the EV kit connects to the parallel port of a computer running Windows® 95, 98, or 2000. Software, included with the EV kit, provides a quick and easy method to control the DAC.

To evaluate the MAX8520ETP or MAX8521ETP (QFN version), refer to the MAX8520 evaluation kit.

**Note:** Windows 2000 requires the installation of a driver located on the CD.

UCSP is a trademark of Maxim Integrated Products, Inc.

Windows is a registered trademark of Microsoft Corp.

SPI is a trademark of Motorola, Inc.

### Features

- ◆ Circuit Footprint Less than 0.31in<sup>2</sup>
- ◆ Operates from a Single Supply (3V to 5.5V)
- ◆  $\pm 1.5A$  Output Current
- ◆ High-Efficiency Switch-Mode Design
- ◆ Programmable Heating/Cooling Current Limit
- ◆ TEC Current Monitor Output
- ◆ 500kHz or 1MHz Switching Frequency
- ◆ SPI™-Compatible Serial Interface
- ◆ Easy-to-Use Menu-Driven Software
- ◆ Includes Windows 95/98/2000-Compatible Software and Demo PC Board
- ◆ Surface-Mount Construction
- ◆ Fully Assembled and Tested

Evaluates: MAX8521

### Ordering Information

PART	TEMP RANGE	IC PACKAGE
MAX8521EVKIT	0°C to +70°C	36 UCSP™

### Component List

DESIGNATION	QTY	DESCRIPTION
C1, C2, C3, C5, C11, C20	6	1 $\mu$ F $\pm 10\%$ , 6.3V X5R (0603) ceramic capacitors Murata GRM188R60J105K Taiyo Yuden JMK107BJ105KA
C4, C10, C16	3	10 $\mu$ F $\pm 20\%$ , 6.3V X5R (0805) ceramic capacitors Taiyo Yuden JMK212BJ106MG
C6, C7, C12, C13, C14	5	0.1 $\mu$ F $\pm 10\%$ , 25V X5R (0603) ceramic capacitors Murata GRM188R71E104K Taiyo Yuden TMK107BJ104KA
C8	1	0.047 $\mu$ F $\pm 10\%$ , 10V X7R (0402) ceramic capacitor Murata GRP155R71A473K
C9	0	Not installed (1206)
C15	0	Not installed (0603)
C17	1	0.022 $\mu$ F $\pm 10\%$ , 50V X7R (0603) ceramic capacitor Murata GRM188R71H223K

DESIGNATION	QTY	DESCRIPTION
C18	1	10 $\mu$ F $\pm 20\%$ , 4V X5R (0603) ceramic capacitor TDK C1608X5R0G106M
C21	1	150 $\mu$ F $\pm 20\%$ , 6.3V, 18m ESR, 2.8A, D2E size, POSCAP Sanyo 6TPE150MI
J1	1	DB25 male right-angle connector
J2	1	2-pin header
J3–J6	0	Not installed
J7, J8	2	3-pin headers
L1, L2	2	2.2 $\mu$ H, 1.6A inductors Sumida CDRH2D18/HP-2R2
Q1, Q2, Q3	3	npn bipolar transistors, 40V, SOT23 Central Semiconductor CMPT3904
R1	1	0.1 $\Omega$ $\pm 1\%$ , 0.25W (1206) sense resistor Panasonic ERJ8RSFR10
R3	1	47k $\Omega$ $\pm 5\%$ (0402) resistor
R4	1	100k $\Omega$ $\pm 1\%$ (0402) resistor

# MAX8521 Evaluation Kit

## Component List (continued)

DESIGNATION	QTY	DESCRIPTION
R5-R8, R24	0	Not installed (0402)
R9, R10, R11	3	4.7k $\Omega$ $\pm$ 5% (0603) resistors
R12-R15, R18	5	1k $\Omega$ $\pm$ 5% (0603) resistors
R16	1	240k $\Omega$ $\pm$ 5% (0603) resistor
R17	1	47k $\Omega$ $\pm$ 1%, (0603) resistor
R19	1	10 $\Omega$ $\pm$ 5% (0603) resistor
R20	1	10k $\Omega$ $\pm$ 0.1%, 25ppm/ $^{\circ}$ C (0805) resistor Panasonic ERA6YEB103

DESIGNATION	QTY	DESCRIPTION
R21, R22	0	Not installed (0603)
R23	1	10k $\Omega$ potentiometer (multiturn)
SW1	1	Switch, momentary, NO
U1	1	Power driver, 36-pin UCSP MAX8521EBX
U2	1	Op amp, SOT23-6 MAX4238AUT-T
U3	0	Not installed, SO-8
U4	1	Serial, 14-bit DAC, 10-pin $\mu$ MAX <sup>®</sup> MAX5144EUB

## Component Suppliers

SUPPLIER	PHONE	FAX	WEBSITE
Central Semiconductor	631-435-1110	631-435-1824	www.centralsemi.com
Murata	770-436-1300	770-436-3030	www.murata.com
Panasonic	714-373-7366	714-737-7323	www.panasonic.com
Sanyo	619-661-6835	619-661-1055	www.sanyodevice.com
Sumida	847-545-6700	847-545-6720	www.sumida.com
Taiyo Yuden	800-348-2496	847-925-0899	www.t-yuden.com
TDK	847-803-6100	847-390-4405	www.component.tdk.com

**Note:** Indicate you are using the MAX8521 when contacting these manufacturers.

## Quick Start

### Required Equipment

The following equipment is required before beginning:

- A DC power supply capable of supplying any voltage between 3V and 5.5V at 1.5A
- A Peltier TEC module with a thermistor (NTC, 10k $\Omega$  at +25 $^{\circ}$ C)
- A digital voltmeter (DVM)

The MAX8521 EV kit is a fully assembled and tested surface-mount board. Follow the steps below to verify board operation. **Do not turn on the power supply until all connections are completed:**

- 1) Place a shunt across J2 to connect the thermal loop to CTLL.
- 2) Place a shunt across pins 1 and 2 on J8 to select the potentiometer.
- 3) Place a shunt across pins 2 and 3 on J7 to disable the MAX8521 output.

- 4) Obtain TEC module specifications for absolute maximum TEC voltage and absolute maximum current. Set these (or lower) limits at the MAX8521's MAXV, MAXIP, and MAXIN inputs. See Tables 1, 2, and 3 to select resistors or refer to the MAX8520/MAX8521 data sheet.
- 5) Connect the TEC module to OS1, OS2, THERM, and GND. Typical connections for most modules are:
  - a) Module TEC- to OS2
  - b) Module TEC+ to OS1
  - c) Module thermistor to THERM
  - d) 2nd module thermistor pin to GND
  - e) Module case ground or shield to GND
- 6) Connect the DVM to SET-POINT IN and GND.
- 7) Connect a 3.3V or 5V DC power supply with sufficient power rating to VDD and GND.

$\mu$ MAX is a registered trademark of Maxim Integrated Products, Inc.

# MAX8521 Evaluation Kit

- 8) Turn on the power supply.  
**Note:** The MAX8521 output is not enabled yet.
- 9) Adjust R23 until the DVM reads 0.75V. This adjusts the set point for approximately +25°C.
- 10) Move the DVM positive lead to THERM and verify a voltage of approximately 0.75V. This represents ambient temperature at the TEC module.
- 11) Enable the MAX8521 by moving the shunt on J7 to the 1 and 2 position.
- 12) After enabling the MAX8521, verify that the THERM voltage converges toward the set-point voltage on R23 (set to 0.75V in step 9) after approximately 30 seconds. The easiest way to measure the convergence is to place a DVM between THERM and SET-POINT. The voltage should read less than 100µV. If the TEC is connected backwards, the THERM voltage will move away from 0.75V toward either 0V or 1.5V. If this occurs, shut down the MAX8521 and reverse the TEC+ and TEC- connections.
- 13) Once proper operation is verified, other temperatures can be set with R23, the DAC, or an external voltage applied to SET-POINT IN. (1V is approximately +10°C; 0.5V is approximately +40°C. The slope is approximately -14mV/°C for a typical NTC thermistor.)

## Detailed Description

### Voltage and Current-Limit Settings

The MAX8521 provides control of the maximum differential TEC voltage and the maximum positive and negative TEC current. The voltage on the MAXV pin of the MAX8521 sets the maximum differential TEC voltage. Use the following equations to set the voltage:

$$\text{Voltage on MAXV: } V_{\text{MAXV}} \text{ (V)} = \text{REF} \times \frac{R4}{R3+R4}$$

$$\text{Maximum TEC voltage: } V_{\text{TEC(MAX)}} = 4 \times V_{\text{MAXV}}$$

The components installed on the MAX8521 EV kit set  $V_{\text{MAXV}}$  to 1V, for a maximum TEC voltage of 4V. See Table 1 or refer to the MAX8520/MAX8521 data sheet for more information. The voltages on the MAXIP and MAXIN pins set the maximum positive and negative current through the TEC. Use the following equations to set the currents:

$$\text{Voltage on MAXIP: } V_{\text{MAXIP}} \text{ (V)} = \text{REF} \times \frac{R6}{R5+R6}$$

$$\text{Voltage on MAXIN: } V_{\text{MAXIN}} \text{ (V)} = \text{REF} \times \frac{R8}{R7+R8}$$

Resistor values for R2 through R7 should be between 10kΩ and 100kΩ.

$$I_{\text{TECP(MAX)}} \text{ (A)} = + \frac{V_{\text{MAXIP}}}{10 \times R_{\text{SENSE}}}$$

where  $R_{\text{SENSE}}$  (R1) is 100mΩ.

Maximum negative TEC current:

$$I_{\text{TECN(MAX)}} \text{ (A)} = - \frac{V_{\text{MAXIN}}}{10 \times R_{\text{SENSE}}}$$

The components installed on the MAX8521 EV kit set the maximum positive current to +1.5A and the maximum negative current to -1.5A. See Tables 2 and 3 or refer to the MAX8520/MAX8521 data sheet for more information.

### Jumper J2

Jumper J2 connects the current control input (CTLI) of the MAX8521 to the error signal of the thermal loop. The thermal-loop circuit compares thermistor feedback from the TEC module to the set-point voltage to generate the CTLI signal.

To drive CTLI directly, remove the shunt on J2 and apply a DC voltage between 0 and 3V to the CTLI pad. A 1.5V voltage on CTLI sets a TEC current of approximately 0A. A voltage of 0V or 3V on CTLI produces -1.5A or +1.5A, respectively. The current changes proportionally with the voltage applied to CTLI.

**Note:** The current will not reach ±1.5A if the maximum positive and negative current limits are set to lower values. Refer to the *Voltage and Current-Limit Settings* section in the MAX8520/MAX8521 data sheet for more information.

### Jumper J6

Jumper J6 sets the switching frequency for the MAX8521. Position 1-2 sets the frequency to 1MHz. Position 2-3 sets it to 500kHz.

**Note:** The MAX8521 is shipped with a short across pins 1 and 2 of J6.

### Jumper J7

The MAX8521 can be placed in shutdown mode using jumper J7. See Table 4 for jumper settings.

# MAX8521 Evaluation Kit

## Jumper J8

Jumper J8, position 2-3, connects the DAC to the thermal-loop circuit. Connect the EV kit to the parallel port of a computer and use the EV kit software to control the DAC. Position 1-2 connects potentiometer R23 to the thermal-loop circuit. To use an external voltage to control the thermal loop, remove the shunt from J8 and apply the voltage to the SET-POINT IN pad. A voltage of +0.75V corresponds to approximately +25°C. 1V is approximately +10°C, and 0.5V is approximately +40°C. The slope is approximately -14mV/°C for a typical NTC thermistor.

## Switch SW1

Switch SW1 resets the DAC to 0.75V.

## ITEC Current-Monitor Output

The ITEC output provides a voltage proportional to the actual TEC current.  $V_{ITEC} = REF$  when the TEC current is zero. The actual TEC current is:

$$I_{TEC} = \frac{V_{ITEC} - 1.5V}{8 \times R1}$$

Use ITEC to monitor the cooling or heating current through the TEC module. Positive values of  $I_{TEC}$  indicate heating for typically connected modules. For stability, keep the ITEC output capacitance below 150pF.

## Controlling TEC Through a Parallel Port

### Required Equipment

In addition to the equipment listed under the *Quick Start* section, you will need the following:

- A computer running Windows 95, 98, or 2000 (**Note:** Windows 2000 requires the installation of a driver located on the CD.)
- A parallel printer port (DB25 on the back of the computer)
- A standard 25-pin, straight-through, male-to-female cable (printer extension cable) to connect the computer's parallel port to the MAX8521 EV kit

### Procedure

- 1) Place a shunt across J2 to connect the thermal loop to CTLI.
- 2) Place a shunt across pins 2 and 3 on J8 to select the DAC.
- 3) Place a shunt across pins 2 and 3 on J7 to disable the MAX8521 output.

**Table 1. Maximum TEC Voltage**

V <sub>TEC(MAX)</sub>	R3	R4
4V	47kΩ	100kΩ
2.6V	130kΩ	100kΩ

**Table 2. Maximum Positive TEC Current**

I <sub>TECP(MAX)</sub>	R5	R6
1.5A	Short	Open
0.75A	100kΩ	100kΩ
0.5A	100kΩ	49.9kΩ

**Table 3. Maximum Negative TEC Current**

I <sub>TECN(MAX)</sub>	R7	R8
1.5A	Short	Open
0.75A	100kΩ	100kΩ
0.5A	100kΩ	49.9kΩ

**Table 4. Jumper Selection**

JUMPER	JUMPER POSITION	FUNCTION
J7	1-2	SHDN = High. MAX8521 enabled.
	2-3*	SHDN = Low. MAX8521 disabled.
J6	1-2*	MAX8521 switching frequency is 1MHz.
	2-3	MAX8521 switching frequency is 500kHz.
J2	Open	Drive the CTLI pad directly with a DC voltage. Disconnects the thermal-loop circuit.
	Closed*	Thermal-control loop is closed. DAC or R23 generates temperature set point.
J8	1-2	DAC generates temperature set point.
	2-3*	Potentiometer R23 generates temperature set point.
	Open	Voltage applied to SET-POINT IN generates temperature set point.

\*Default position.

# MAX8521 Evaluation Kit

- 4) Obtain TEC module specifications for absolute maximum TEC voltage and absolute maximum current. Set these (or lower) limits at the MAX8521 MAXV, MAXIP, and MAXIN inputs. See Tables 1, 2, and 3 to select resistors or refer to the MAX8521 data sheet.
- 5) Connect the TEC module to OS1, OS2, THERM, and GND. Typical connections for most modules are:
  - a) Module TEC- to OS2
  - b) Module TEC+ to OS1
  - c) Module thermistor to THERM
  - d) 2nd module thermistor pin to GND
  - e) Module case ground or shield to GND

Be sure to check your module specifications before making connections. Also, it is recommended that the thermistor be connected through shielded wire for lowest noise.

- 6) Connect a cable from the computer's parallel port to the MAX8521 EV kit. Use a straight-through, 25-pin female-to-male cable. To avoid damaging the EV kit or your computer, do not use a 25-pin SCSI port or any other connector that is physically similar to the 25-pin parallel printer port.
- 7) Install the software by running the INSTALL.EXE program. The install program copies the files and creates icons for them in the Windows 95/98/2000 Start menu. Click on the UNINSTALL icon to remove the EV kit software from the hard drive.
- 8) Connect a 3.3V or 5V DC power supply with sufficient power rating to VDD and GND.
- 9) Turn on the power supply.
- 10) Start the MAX8521 program by opening its icon in the Start menu. At program startup, the software forces the DAC to 0.75V, which corresponds to approximately +25°C.
- 11) Connect the DVM to THERM and verify a voltage of approximately 0.75V. This represents ambient temperature at the TEC module.
- 12) Enable the MAX8521 by moving the shunt on JU1 to the 1-2 position.
- 13) After enabling the MAX8521, verify that the THERM voltage converges toward the DAC voltage (0.75V) after approximately 30 seconds. The easiest way to measure the convergence is to place a DVM between THERM and SET-POINT. The voltage should read less than 100µV. If the TEC is connected backwards, the THERM voltage will move away from 0.75V toward either 0V or

1.5V. If this occurs, shut down the MAX8521 and reverse the TEC+ and TEC- connections.

- 14) Once proper operation is verified, other temperatures can be set with the DAC. See the *Software User Interface* section.

## Software User Interface

The user interface is easy to operate using either the mouse or the Tab key to navigate. To program the DAC, enter the ratio of the desired DAC output voltage (VDAC) to the reference voltage (REF):

$$\text{ratio} = \left( \frac{V_{\text{DAC}}}{\text{REF}} \right), \text{ where REF} = +1.5\text{V}$$

The ratio must be a decimal number between 0 and 1. Press Enter or click on the Update button to send the data to the DAC. The program starts with a ratio of 0.5. This sets the DAC output to 0.75V, which corresponds to +25°C. A ratio of 0.67 sets the DAC output to 1V, which corresponds to approximately +10°C. A ratio of 0.33 sets the DAC output to 0.5V or approximately +40°C. The slope is approximately -14mV/°C for a typical NTC thermistor.

## General-Purpose SPI Utility

There are two methods for communicating with the MAX5144 DAC: through the user-interface panel or through the general-purpose SPI utility. This utility (Figure 3) configures SPI parameters such as clock polarity (CPOL), clock phase (CPHA), and chip-select (CS) polarity. The fields where pin numbers are required apply to the pins of the parallel port connector.

The utility handles the data only in byte (8-bit) format. Data longer than a byte must be handled as multiple bytes. For example, a 16-bit word should be broken into two 8-bit bytes. To write data to the slave device, enter the data into the field labeled "Data bytes to be written." Each data byte should be hexadecimal, prefixed by 0x, and separated with a comma. Press the Send Now button to write the data to the slave.

To read data from the slave device, the field "Data bytes to be written:" must contain hexadecimal values. Include the same number of bytes as to be read from the slave.

**Note:** The MAX5144 is a write-only device and cannot be read.

# MAX8521 Evaluation Kit

Evaluates: MAX8521

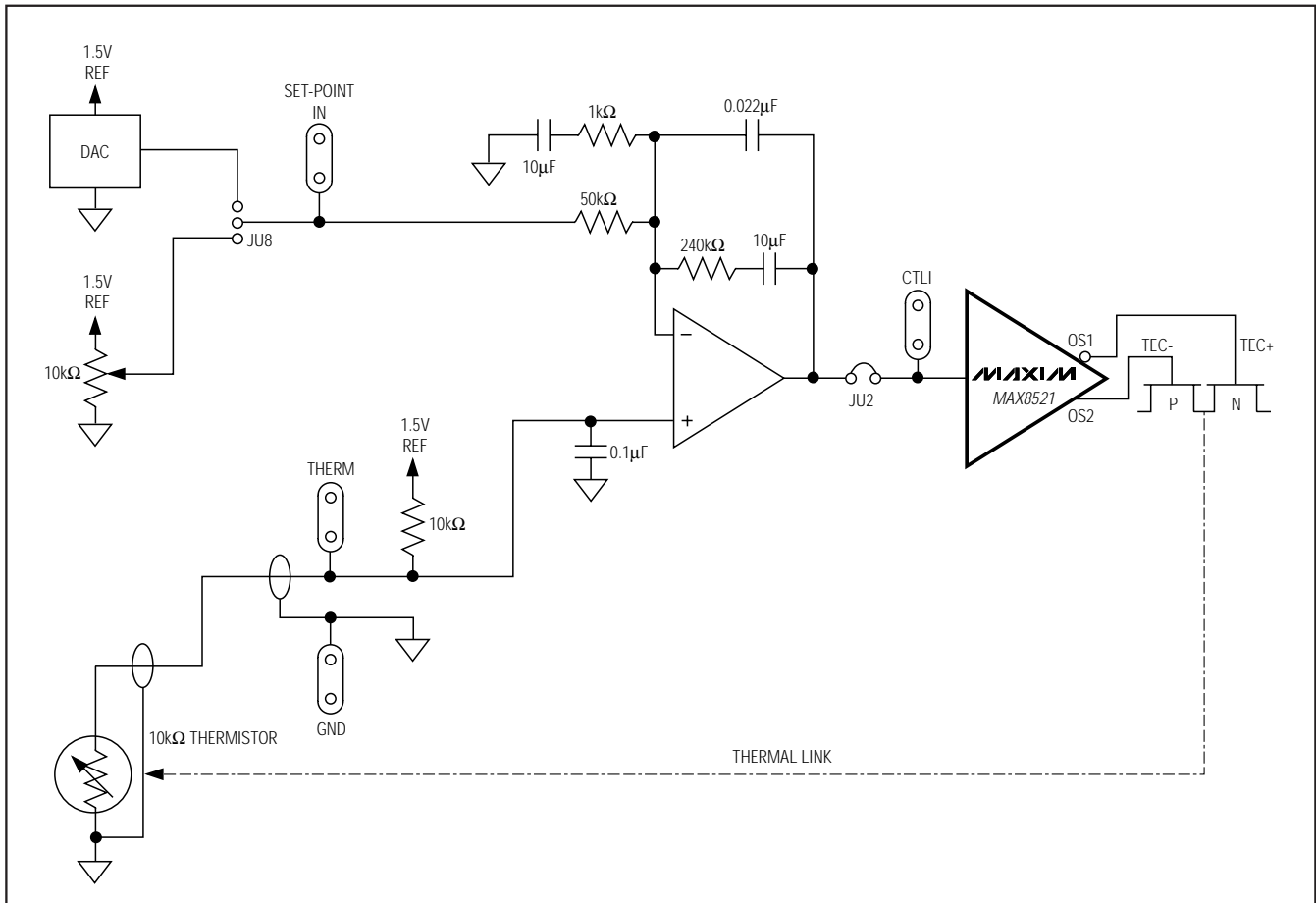

Figure 1. Thermal-Loop Functional Diagram for the MAX8521 EV Kit

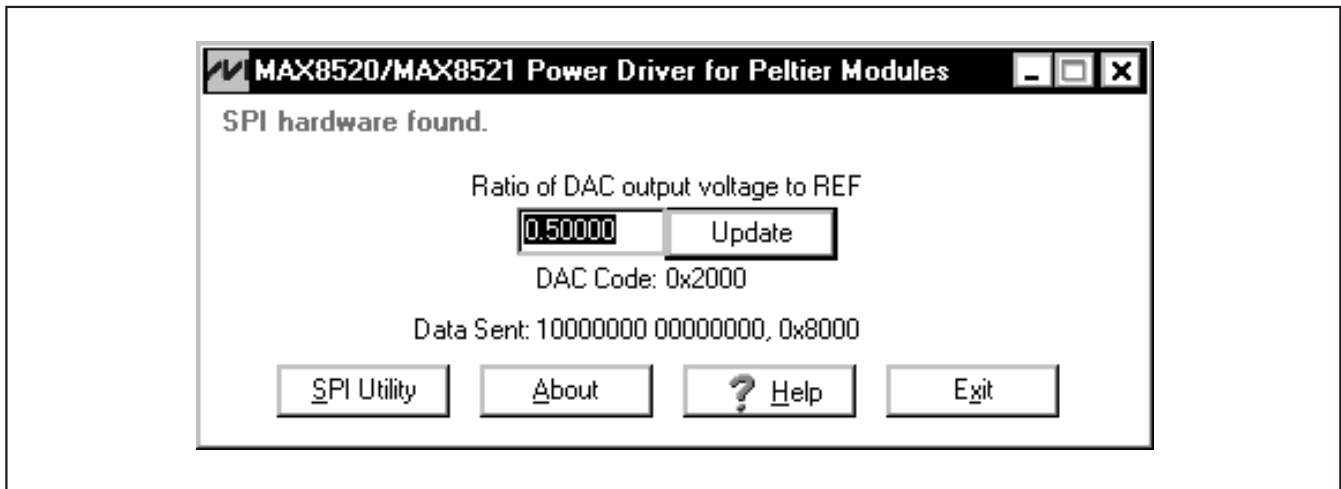

Figure 2. Main Window for the MAX8521 EV Kit

# MAX8521 Evaluation Kit

Evaluates: MAX8521

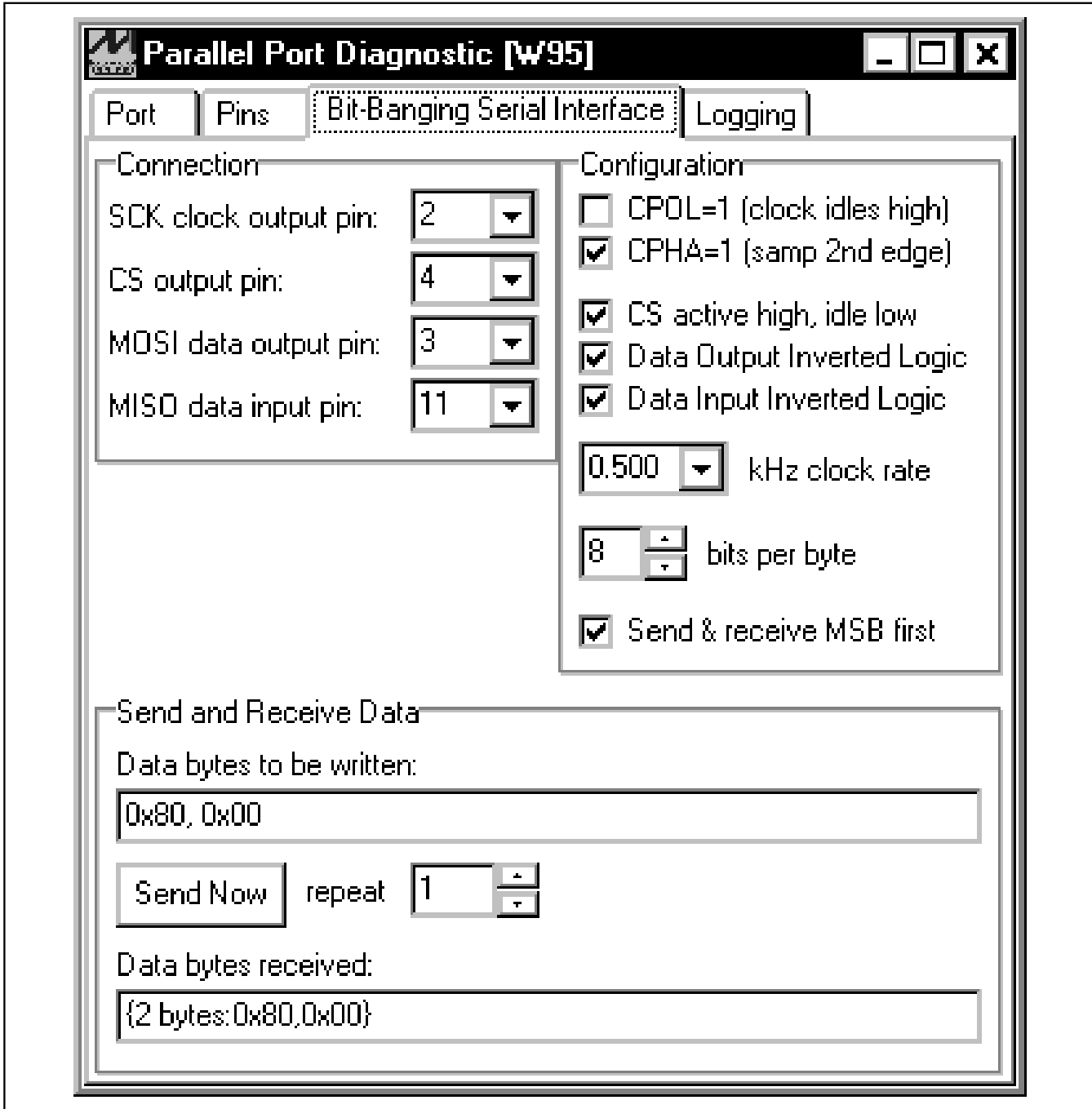

Figure 3. SPI Utility Showing the Settings to Communicate with the MAX8521 EV Kit





# MAX8521 Evaluation Kit

Evaluates: MAX8521

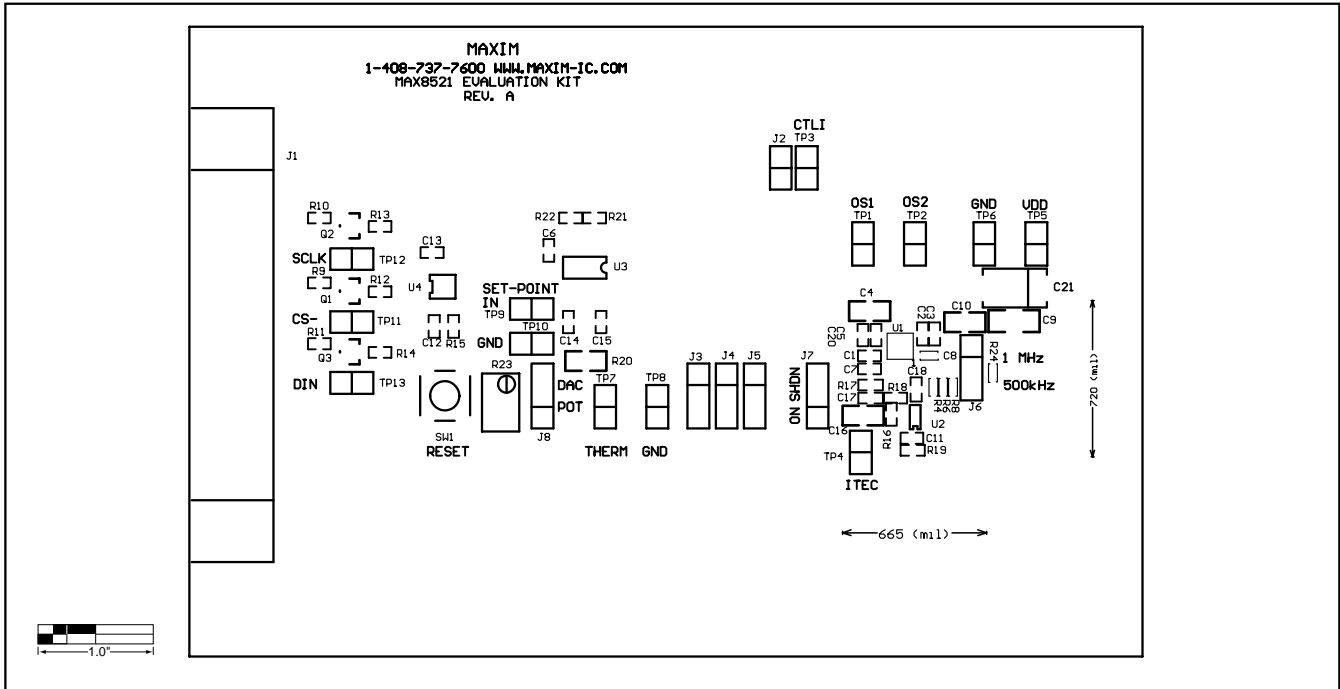

Figure 5. MAX8521 EV Kit Component Placement Guide—Component Side

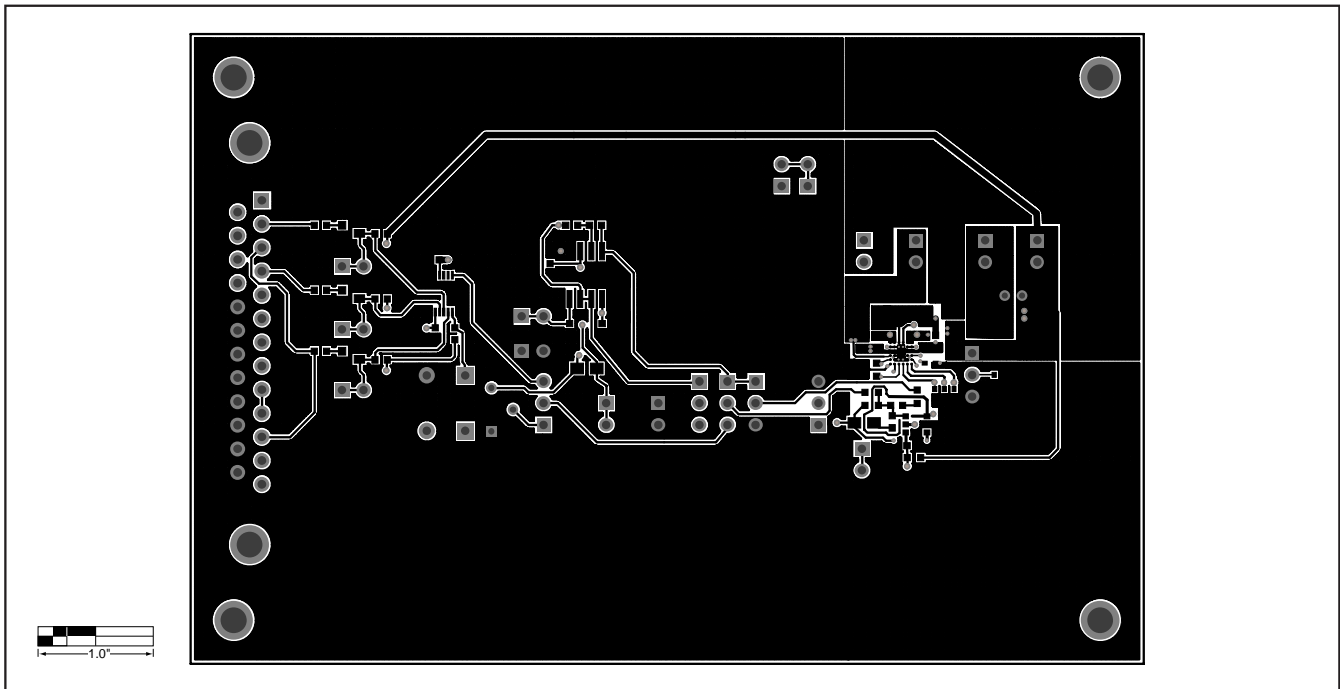

Figure 6. MAX8521 EV Kit PC Board Layout—Component Side

# MAX8521 Evaluation Kit

Evaluates: MAX8521

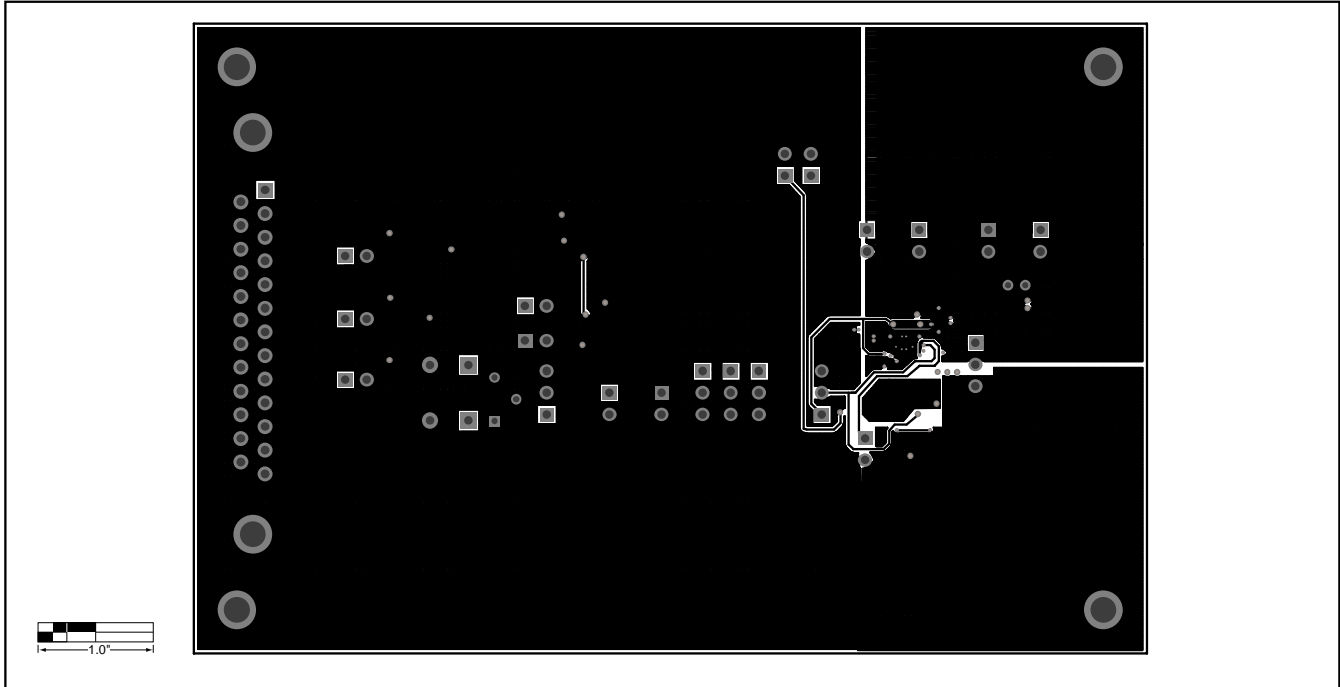

Figure 7. MAX8521 EV Kit PC Board Layout—Layer 2

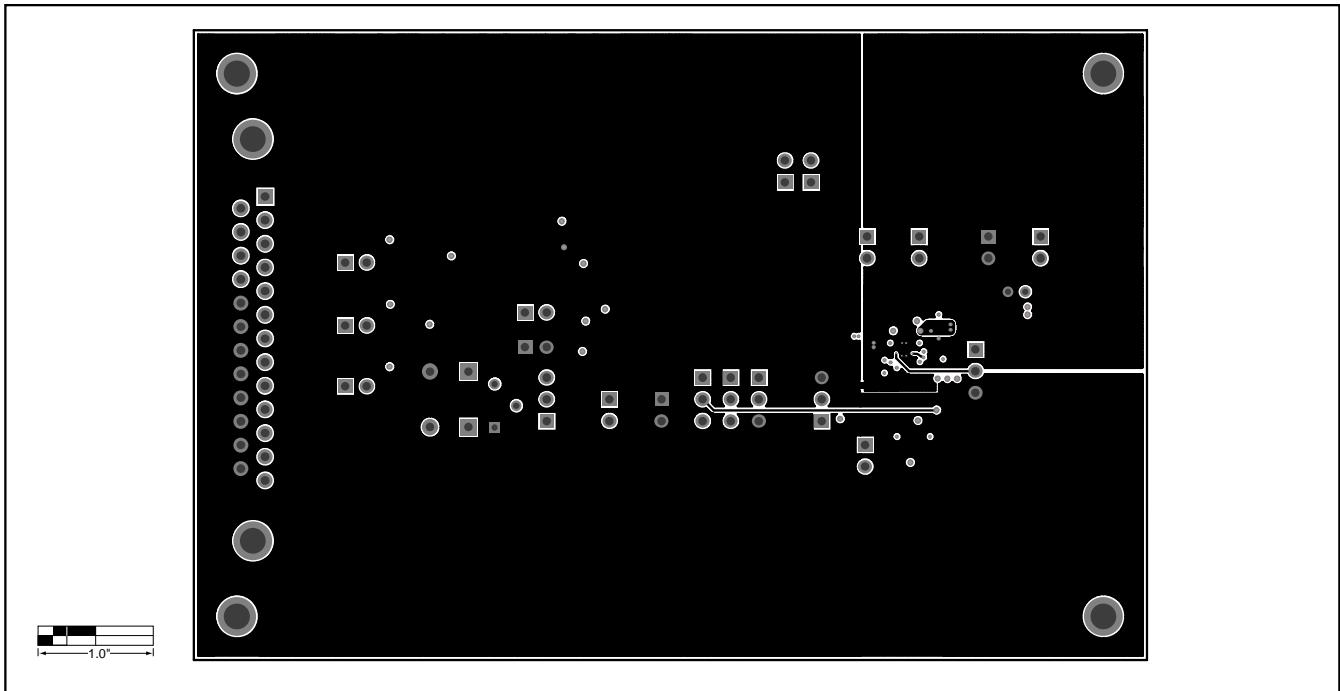

Figure 8. MAX8521 EV Kit PC Board Layout—Layer 3

# MAX8521 Evaluation Kit

Evaluates: MAX8521

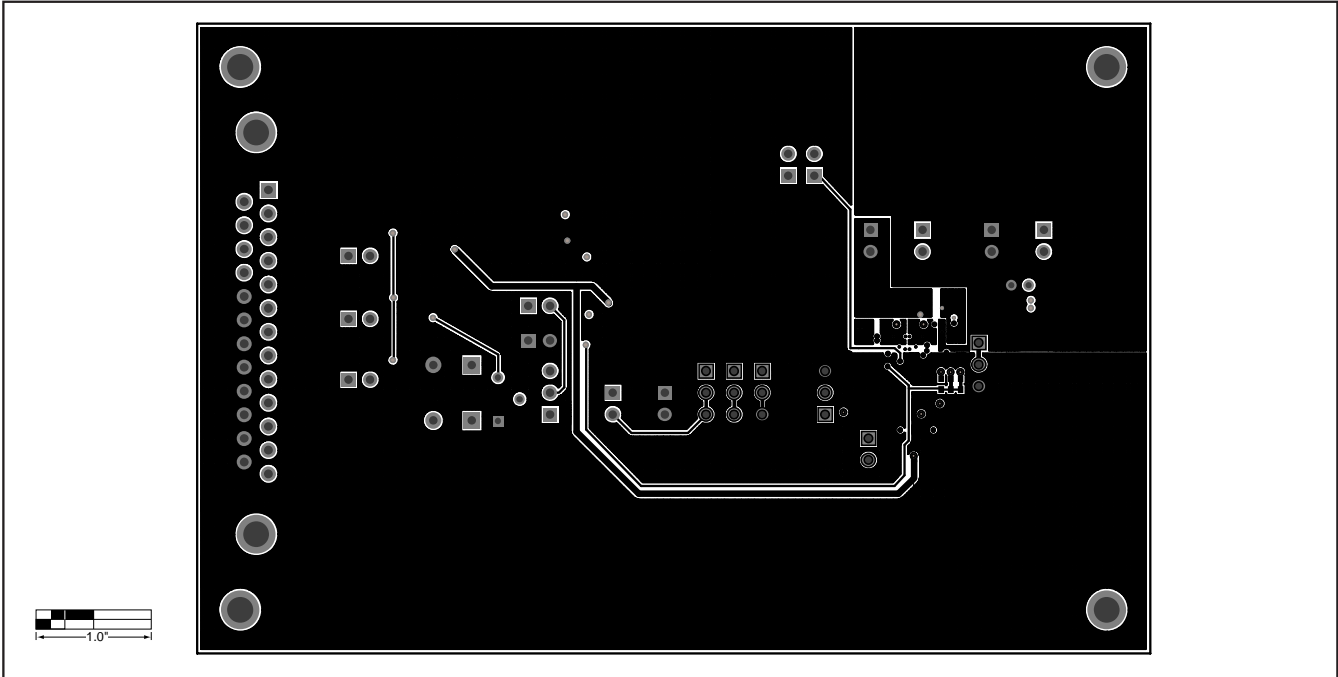

Figure 9. MAX8521 EV Kit PC Board Layout—Solder Side

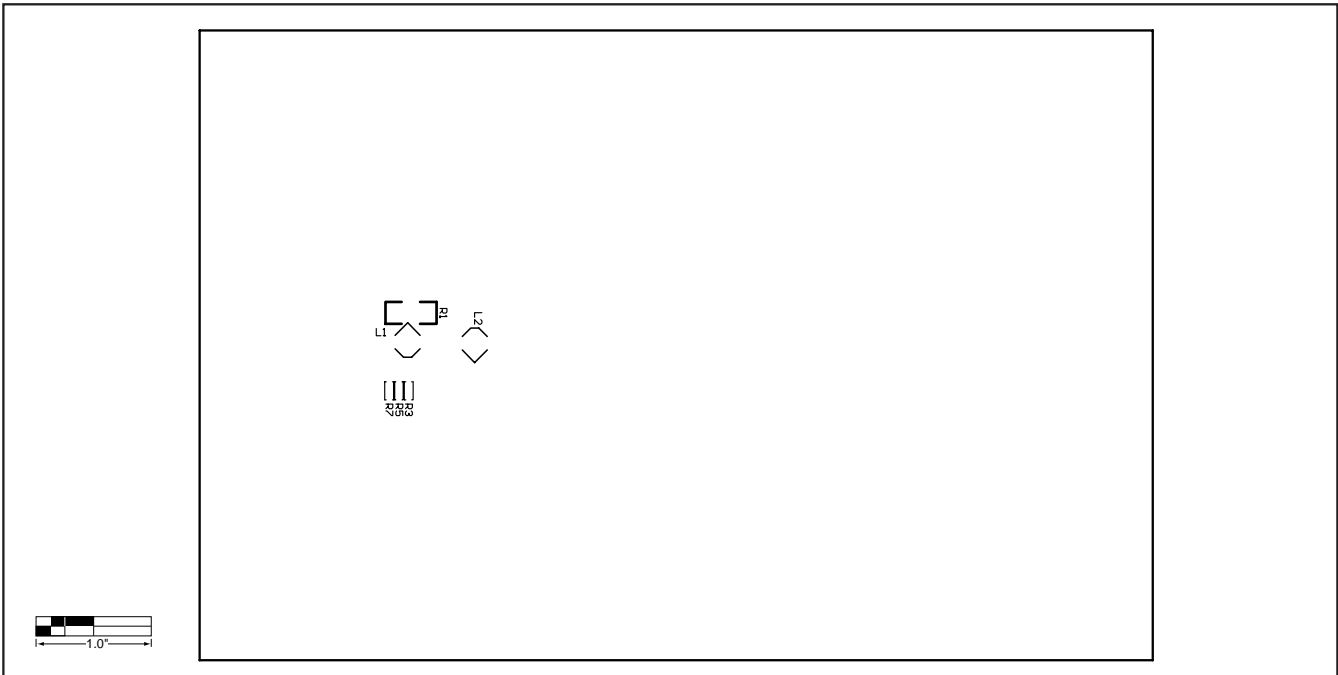

Figure 10. MAX8521 EV Kit Component Placement Guide—Solder Side

Maxim cannot assume responsibility for use of any circuitry other than circuitry entirely embodied in a Maxim product. No circuit patent licenses are implied. Maxim reserves the right to change the circuitry and specifications without notice at any time.

Maxim Integrated Products, 120 San Gabriel Drive, Sunnyvale, CA 94086 408-737-7600 \_\_\_\_\_ 11