

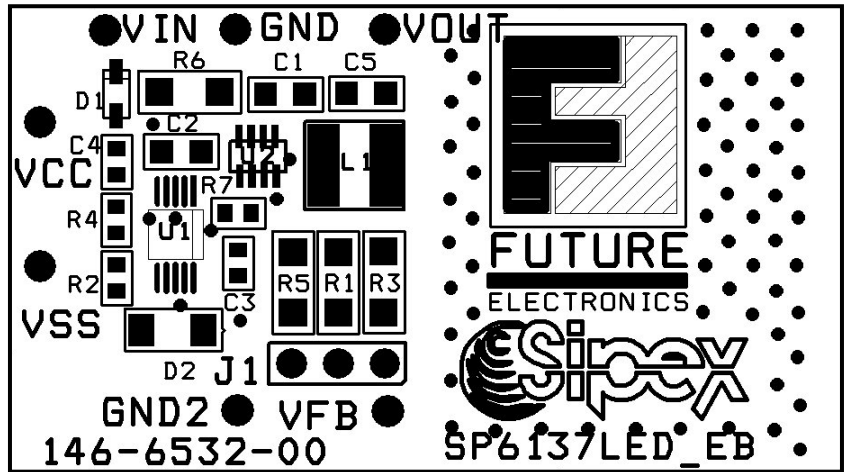

# SP6137LED Evaluation Board Manual

- Ideal for Automotive or 12V Bus Application
- Single Board for 1W, 3W and 5W Applications
- High Efficiency
- Small 10-Pin MSOP Package
- 900kHz Switching Frequency Enables Small Components
- Integrated Design with Minimal Components.
- Dual MOSFET for Spacing Saving



## DESCRIPTION AND BOARD SCHEMATIC

The **SP6137LED Evaluation Board** is designed to help the user evaluate the performance of the SP6137 for use as a Luxeon 1W/3W/5W Driver. The evaluation board is a completely assembled and tested surface mount board which provides easy probe access points to all SP6137 inputs and outputs so that the user can quickly connect and measure electrical characteristics and waveforms.

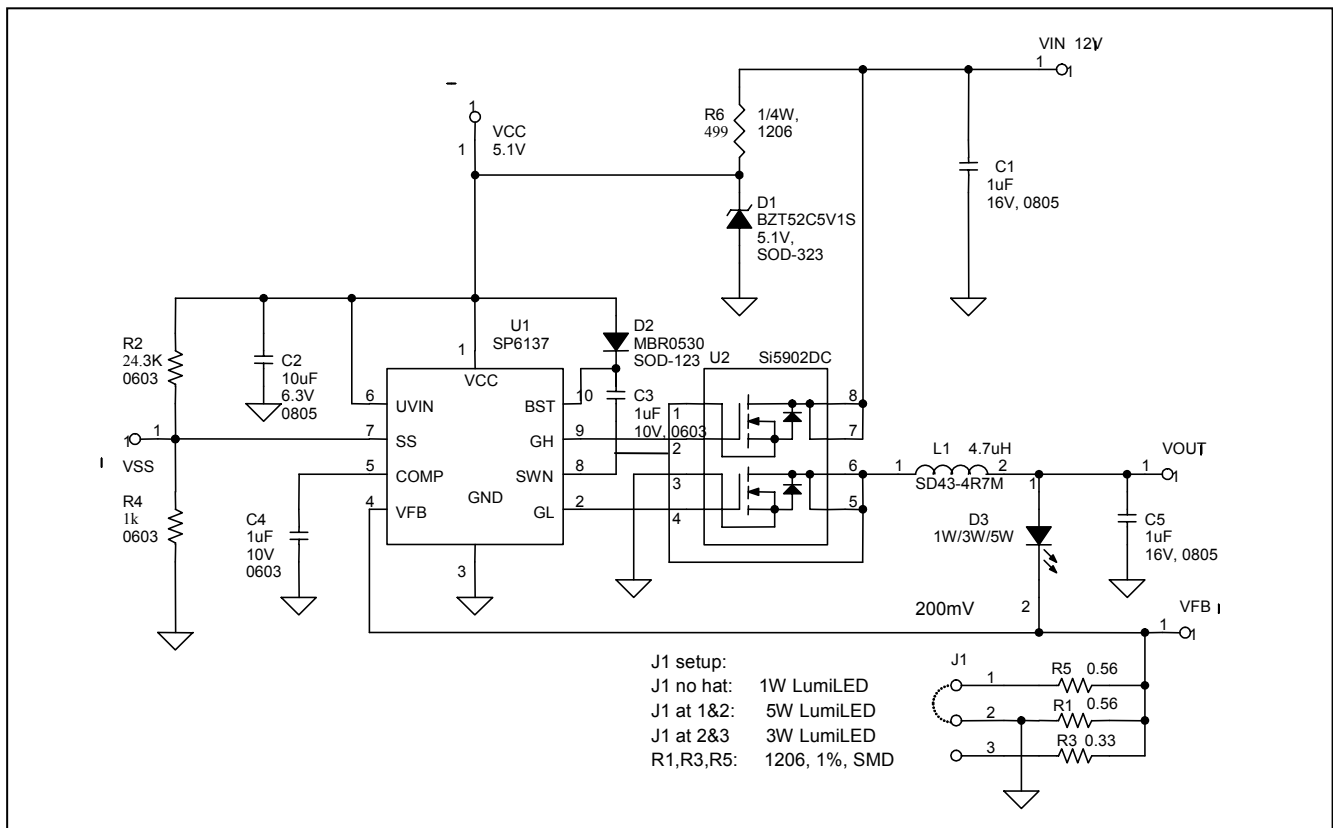

## USING THE EVALUATION BOARD

### 1) Powering Up the SP6137LED Circuit

The SP6137LED Evaluation Board can be powered from a 12V power supply or from 8 alkaline cells. Connect with short leads directly to the “VIN” and “GND” posts. Plug the 1W/3W/5W Luxeon LumiLED between the “VOUT” and “VFB” posts. Refer to section 2 for Jumper (J1) setup for different LumiLED applications.

### 2) Using the J1 Jumper for different LumiLED Applications

The SP6137LED Evaluation Board can be used to drive 1W, 3W or 5W LumiLED respectively, this can be done by using the J1 Jumper. When no hat was used for the J1, it is setup for 1W application. When the hat is put on 1 & 2 position, it is used for 5W application. When the hat is put on 2 & 3 position, it is used for 3W application.

### 3) Selecting the Bias Resistor

The feedback voltage was programmed to be 200mV by using two divider resistors ( $R_2$  and  $R_4$ ) at the soft start pin. (The internal 0.8V reference was overwritten by the programmed 0.2V to reduce the sense voltage and increase the efficiency). The bias resistor is used to set the operating current of the LumiLED as equation

$$R_b = \frac{V_{FB}}{I_F}$$

where  $V_{FB}$  is set as 200mV,  $I_F$  is the operating current of the LumiLED.

For 1W application,  $I_F=350\text{mA}$ ,  $R_b=R_1=0.56\text{Ohm}$

For 5W application,  $I_F=700\text{mA}$ ,  $R_b=R_1//R_5=0.28\text{Ohm}$

For 3W application,  $I_F=1000\text{mA}$ ,  $R_b=R_1//R_3=0.2\text{Ohm}$

## POWER SUPPLY DATA

For the standard evaluation board, the following chart shows the efficiency data for different applications.

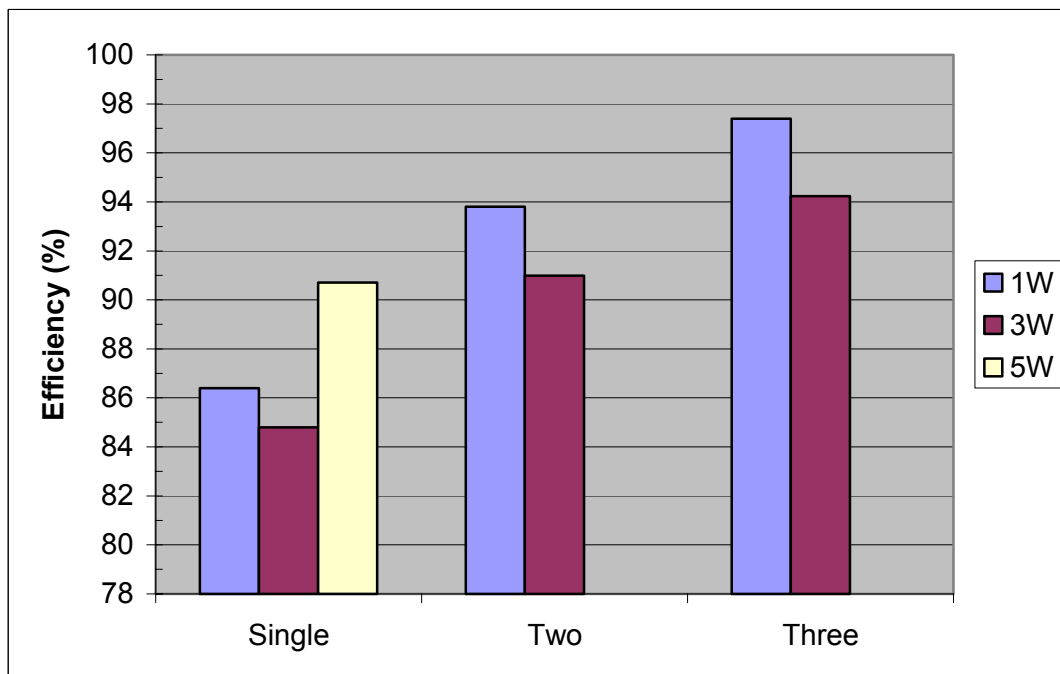

Fig. 1 Efficiency data of the SP6137LED evaluation board

# EVALUATION BOARD LAYOUT

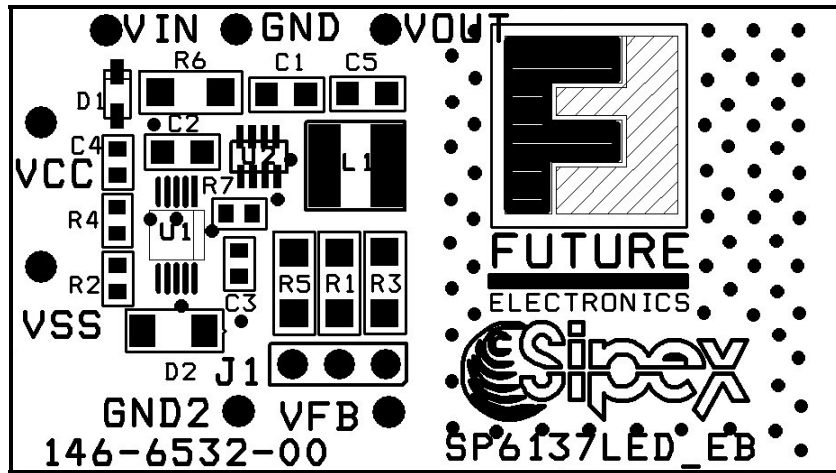

FIGURE 1: SP6137LEDEB COMPONENT PLACEMENT

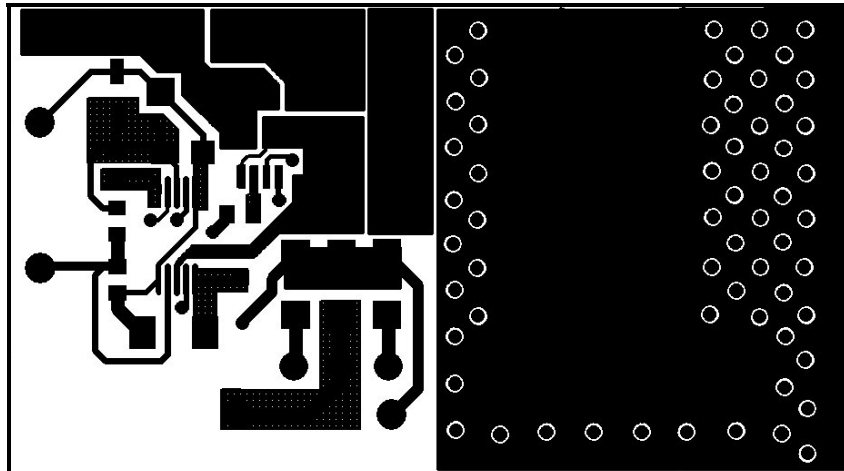

FIGURE 2: SP6137LEDEB PC LAYOUT TOP SIDE

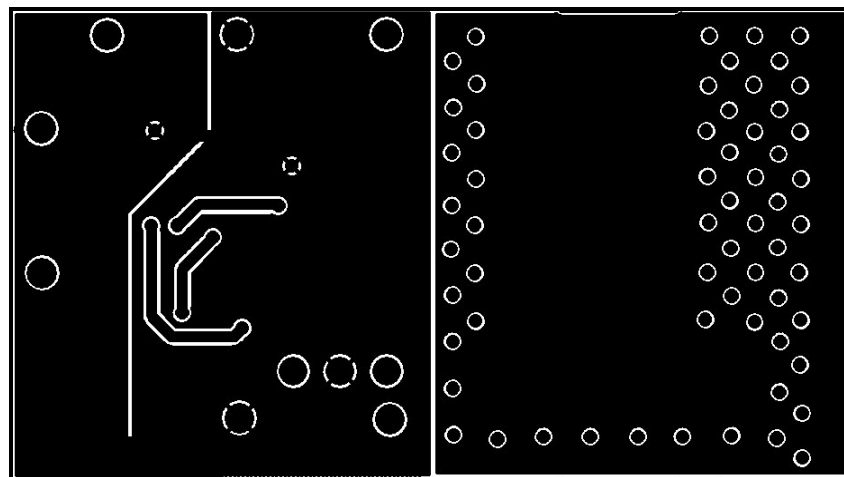

FIGURE 3: SP6137LEDEB PC LAYOUT BOTTOM SIDE

**TABLE1: SP6137LEDEB LIST OF MATERIALS**

SP6137 Buck for LumiLED List of Materials						
Ref. Des.	Qty.	Manufacturer	Part Number	Layout Size	Component	Vendor
				LxWxH		
U1	1	Sipex Corp.	SP6137	MSOP-10	900kHz Dual Supply Synchronous Buck	Sipex 978-667-8700
U2	1	Vishay	SI5902DC	1206-8 ChipFET	Dual N-Channel 30V MOSFET	Vishay
C1, C5	2	TDK Corp	C2012X5R1C105K	805	1uF/16V/X5R/10% Ceramic	TDK 847-803-6100
C2	1	TDK Corp	C2012X5R0J106M	805	10uF/6.3V/X5R/ Ceramic	TDK 847-803-6100
C3, C4	2	TDK Corp	C1608X5R1A105K	603	1uF/10V/X5R/ Ceramic	TDK 847-803-6100
L1	1	Easy Magentic	SD43-4R7M	4X4.5X3.2	4.7uH 2.43A 0.1 Ohm SM Inductor	Easy Magnetic
D1	1	ON Semin	MBR0530	SOD-123	0.5A Schottky	800-388-8731
D2	1	Diodes Inc.	BZT52C5V1S	SOD-323	5.1V SMD zener diode	Diodes Inc.
D3	1	LumiLEDs			Open	LumiLEDs
R1, R5	2	Panasonic		1206	0.56 Ohm 1/4W 1% 1206 SM	800-Digi-Key
R3	1	Panasonic		1206	0.33 Ohm 1/4W 1% 1206 SM	800-Digi-Key
R2	1	Panasonic		603	24.3K Ohm 1/16W 1% 0603 SM	800-Digi-Key
R4	1	Panasonic		603	1K Ohm 1/16W 1% 0603 SM	800-Digi-Key
R6	1	Panasonic		1206	499 Ohm 1/4W 5% 1206 SM	800-Digi-Key
R7	1	Panasonic		603	5 Ohm 1/16W 1% 0603 SM	800-Digi-Key
J1	1				3-Pin Jumper	800-Digi-Key

**ORDERING INFORMATION**

Model	Temperature Range	Package Type
SP6137LEDEB.....	-40°C to +85°C.....	SP6137LED Evaluation Board
SP6137EU.....	-40°C to +85°C.....	10-pin μSOIC