

SHARP

Audio-Visual Systems Group
SHARP Corporation

DOCUMENTATION

Ref. NO : OE2-120-00

ISSUE : JUNE, 24, 1998

PAGE : 31 Pages

TV Systems Division. 1
Audio-Visual Systems Group

DOCUMENTATION for LCD Display

1. Specification 15 Pages
2. Outgoing Inspection Standard 7 Pages
3. Electrical Interface Requirements.. 6 Pages
4. Handling Precautions 3 Pages

Model No.	<u>3L-U8E</u>
Brand Name	<u>SHARP</u>
Customer	<u>S. E. C</u>
Country	<u>U. S. A</u>

PRESENTED

BY 

SIGNATURE (H. Nonaka)

Department General Manager

Product Quality Assurance

Department

TV Systems Division. 1

Audio-Visual Systems Group

**SHARP CORPORATION
SPECIFICATION FOR LCD DISPLAY MONITOR**

GENERAL SPECIFICATION

MODEL : 3L-U8E

1. Input signal	NTSC Video signal Analog RGB signal (Horizontal scan rate 15.734 kHz)
2. Power voltage	DC 8.0 V
3. Power consumption	3.2 W at DC 8.0V
4. Viewing area Dimension	Diagonal 75.4 mm 3 “ Width 61.3 mm Height 43.9 mm
5. Dimensions (Approx.)	77.3 (W) x 65.5 (H) x 18.7 (D) mm
6. Weight (Approx.)	75 g
7. LCD Display Panel	TFT Active Matrix 89,856 Dots (384 H x 234 V) RGB delta arrangement
8. Back light	Cold Cathode Fluorescent Tube L-Shaped Lamp Edge Lighting System
9. Semiconductors (Except LCD panel)	ICs 7 pcs. Transistors 11 pcs. Diodes 11 pcs.
10. Standards Safety standards	UL 1492 under considering

11. External terminal

A connector

A 1 : GND for Lamp drive circuit
 A 2 : + 8 V Input for Lamp drive circuit
 A 3 : + 8 V Input for Lamp drive circuit
 A 4 : + 8 V Input for video signal circuit
 A 5 : GND for video signal circuit
 A 6 : C-Sync GND
 A 7 : C-Sync input
 A 8 : N.C.
 A 9 : Super impose (note 1)
 A10 : Ys input (note 2)
 A11 : Blue signal GND
 A12 : Blue signal input
 A13 : Green signal GND
 A14 : Green signal input
 A15 : Red signal GND
 A16 : Red signal input
 A17 : Video GND
 A18 : Video Input
 A19 : GND
 A20 : Dimming Control
 A21 : Tint control
 A22 : Brightness control
 A23 : Color control
 A24 : Up / Down Reverse scanning (note 3)
 A25 : Left / Right Reverse scanning (note 3)
 A26 : +5.0 V Output
 A27 : Vertical Sync Output
 A28 : Horizontal Sync Output

Connector manufacturer : Molex

Connector model # : 52435-2891

0.5 mm pitch FFC connector

note 1	Normal mode	Superimpose mode
A9	Open	GND
note 2	RGB mode	Video mode
A10	High	GND
note 3	6 o'clock	12 o'clock
A24	High	GND
A25	High	GND

SHARP CORPORATION
ENGINEERING SPECIFICATION

MODEL : 3L-U8E

1. General	Nominal	Limit
1) Power Voltage	DC 8.0 V	7.5 V to 8.5 V
2) Operating temperature Range	25°C	-10°C to 60°C
3) Storage temperature Range		-30°C to 80°C
4) Power Consumption(DC 8.0 V Nominal)		<u>3.2 W ± 20 %</u>
2. Video output characteristics		
Video fidelity (at 100kHz standard, NTSC video signal)		
1 MHz	± 1.0 dB	
2 MHz	-0.6 dB	
3 MHz	-14 dB	
3.58 MHz	-32 dB	
3. Picture quality (at NTSC signal input)		
1) Resolution (ITC pattern)		
Horizontal center	170 lines	150 lines min.
corner	170 lines	150 lines min.
Vertical center	190 lines	170 lines min.
corner	190 lines	170 lines min.
2) Step response		
Rising edge time		500 ns max.
Pre shoot		35 % max.
Over shoot		20 % max.
4. Chroma. Section		
1) Color control range (for information only)		
		3 dB min.
2) Tint control range (for information only)		
To green	30°	12° min.
To purple	30°	12° min.

3) Tint stability (for information only)		
Tint drift	3°	12° max.
Tint shift	3°	12° max.
4) Color Killer level		
	- 27 dB	- 18 dB

5. Liquid crystal display

1) Viewing area		
Diagonal	75.4 mm	
Width	61.3 mm	
Height	43.9 mm	
2) Number of dots		
	89,856 dots (384 x 234)	
3) Pitch of dots		
Horizontal	160 μm	
Vertical	188 μm	
4) Pixels arrangement		
	RGB delta arrangement	
5) Contrast (best viewing position)		
		1:60 min.
6) Response time(at 25 °C)		
rise time	30 m sec.	60 m sec. max.
decay time	50 m sec.	100 m sec. max.
7) Viewing angle (at contrast 1:5 min.)		
Left / Right		- 60 °/ 60 ° min.
Up / Down		35 °/- 60 ° min.
8) Brightness (at 25 °C, after 30 minutes warming up, at DC 8 V, at 100% white video signal, at no dimming mode, brightness adj. Max.)		
	400 cd/m ²	300 cd/m ² min.
9) Surface treatment		
	Anti-glare, hard-coating (initial : 3H)	
10) Dimming range(for information only)		
		100 ~ 15 %

3. Input signal requirement

1) Analog RGB signal

a. Video signal

Input level	0.7 V p-p	0.7 V p-p \pm 20 %
Input impedance		75 Ω \pm 30 %

b. Sync. Signal

Input level	TTL level	L : 0 ~ 0.8V H : 3.5 ~ 5.0 V
Input impedance		9 k Ω
Horizontal scan rate		15.73 kHz \pm 400 Hz
Vertical scan rate		60 \pm 5 Hz

c. Video signal at superimpose mode

Input level	0.4 V p-p
-------------	-----------

When RGB signal is used to superimpose text on composite video Signal, RGB signal shall be smaller than 0.4 V p-p.

2) NTSC Composite Video signal

(Standard signal : luminance order color bar signal with 100% white peak level)

Input level	1.0 V p-p	1.0 V p-p \pm 20 %
Input impedance		75 Ω \pm 30 %

3) Ys signal (A10 terminal)

Input level	TTL level	L : 0 ~ 0.8V H : 3.5 ~ 5.0 V
Input impedance		10 k Ω min.

4) Reverse image selection signal (A24, A25 terminals)

Input level	TTL level	L : 0 ~ 0.8V H : 3.5 ~ 5.0 V
Input impedance		10 k Ω min.

5) Superimpose signal (A9 terminal)

Input level	TTL level	L : 0 ~ 0.8V H : 3.5 ~ 5.0 V
Input impedance		10 k Ω min.

6) Other input

Terminal #	Terminal Symbol	Min.	Typ.	Max.
A20	DIMMER	2.0 V		4.6 V
A22	BRIGHT	2.5 V	3.0 V	4.0 V
A23	COLOR	0 V	3.0 V	4.8 V
A6	TINT	1.0 V	3.1 V	4.8 V

4. Output signals

1) + 5.0 V output (A26 terminal)

Output level	5.0 V \pm 10 %
Maximum output current	10 mA Max.

2) STH signal (A28 terminal), STV signal (A27 terminal)

Output level	C-MOS level
Output Current	\pm 80 μ A Max.
Signal polarity	Negative

5. Signal input timing(H-sync : micro second, V-sync : # of lines)

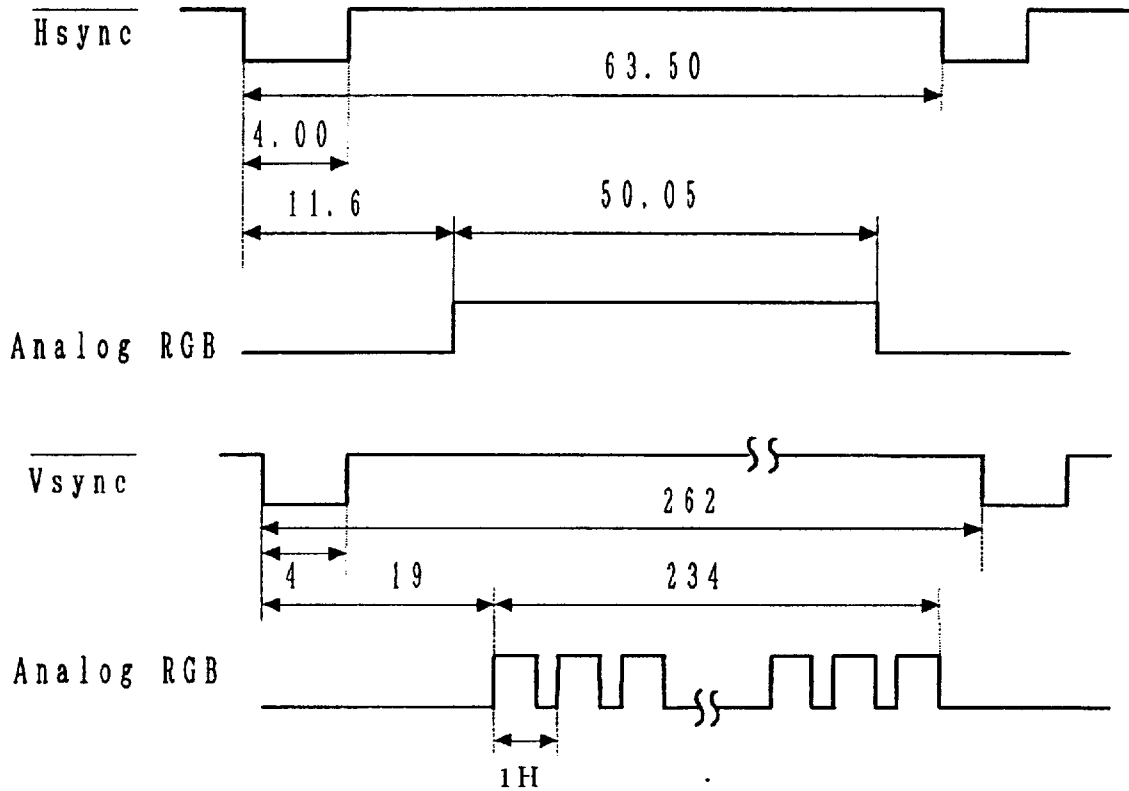

RELIABILITY TEST ITEM

MODEL : 3L-U8E

It is required that LCD chassis unit should be designed to comply with all the following reliability test.

1. Drop test

Drop off the carton, which includes 100 chassis inside, against the floor with 1 corner, 3 edges and 6 surfaces from the height of 60cm.

The floor should be flat surface with horizontal position and made of concrete, rock, steel plate or equivalent.

After drop test, the unit should have no safety hazard and operate as normal usage without any damage.

2. Vibration test

- 1) Conduct the following vibration test with the carton, which includes 100 chassis inside, and should operate as normal usage without any damage after this test.

Frequency(Hz) :	5 to 50
1 cycle period :	3 minutes(back and force)
Acceleration :	1.5G each (X.Y.Z)
Securing :	Banding
Time :	Up/Down 60 minutes
	Forward/Back 15 minutes
	Right/Left 15 minutes

- 2) Endurance vibration test

Conduct the following vibration test with the chassis unit and should operate as normal usage without any damage after this test.

Frequency(Hz) :	10 to 200
Acceleration :	2.0G each (X.Y.Z)
1 cycle period :	20 minutes
Securing :	Screw
Time :	Up/Down 4 hours
	Forward/Back 2 hours
	Right/Left 2 hours

3. Pressure reduction test

Set up the unit in the pressure reduction chamber and reduce the air pressure gradually from the normal pressure to 510hPa(380mmHg) which is equivalent to 5,000m height. There should have no damage to turn on the unit with 10% increased power voltage for 30 minutes and repeat power on and off for 3 times quickly.

4. High temperature storage(without power)

Keep the unit in 80°C temperature chamber for 72 hours without power. Take out the unit to make it normal temperature and make sure that the unit has no safety hazard and operate as normal usage without any damage.

5. Low temperature storage(without power)

Keep the unit in -30°C temperature chamber for 72 hours without power. Take out the unit to make it normal temperature and make sure that the unit has no safety hazard and operate as normal usage without any damage.

6. Humidity test(with power)

Operate the unit in 40°C temperature and 90thru 95% humidity chamber for 90 hours with $\pm 10\%$ increased power. Make sure that the unit has no safety hazard and operate as normal usage without any damage.

7. High temperature test(with power)

Operate the unit for 72 hours with $\pm 10\%$ increased power after keeping the unit in 60°C temperature chamber for 2 hours. Make sure that the unit has no safety hazard and operate as normal usage without any damage.

8. Low temperature test(with power)

Operate the unit for 72 hours with $\pm 10\%$ increased power after keeping the unit in -10°C temperature chamber for 2 hours. Make sure that the unit has no safety hazard and operate as normal usage without any damage.

9. Electrostatic discharge test

Discharge DC8kV under operating, DC15kV under non operating to chassis angle for 10 times of 1 second interval with $500\ \Omega$, 200pF prove.

Under operating : The unit should operate without any trouble during operation.
Under non operating : No component damage
exception : This will not be applied when the unit recovered from the trouble after powering it off and then on.
This test will not be applied to Input / Output connector terminal.

10. Thermal shock test

Keep the unit in the following temperature chamber without power.

Take out the unit to make it normal temperature and make sure that the unit has no safety hazard and operate as normal usage without any damage.

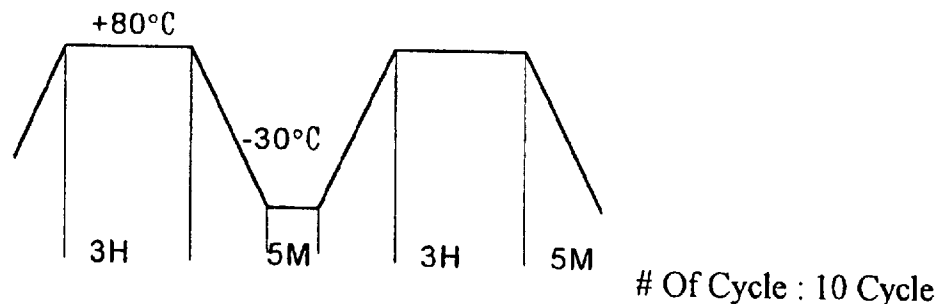

11 A

3L-U8E

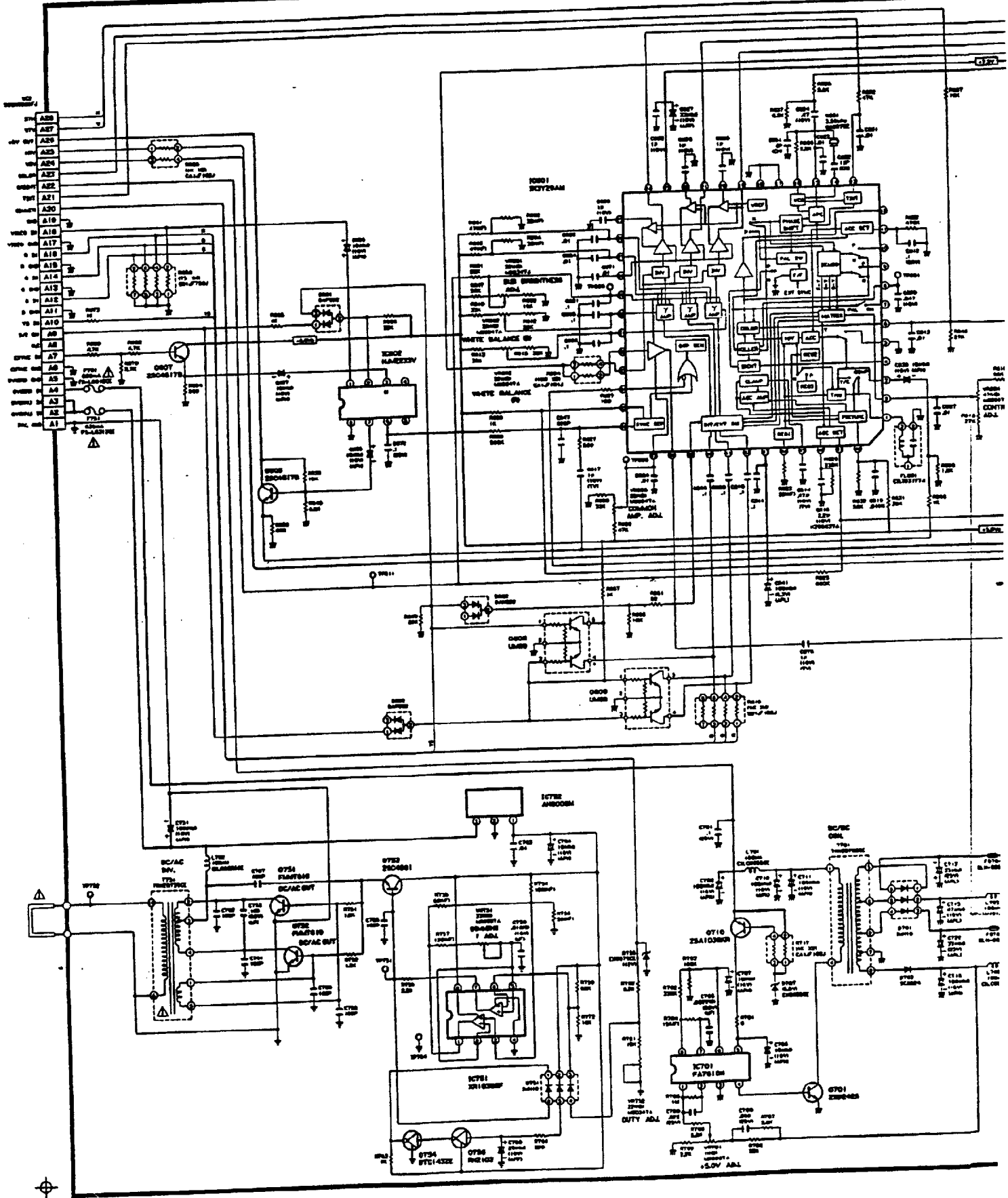

OUTPUT TIME: 11-JUN-1998 10:50:20 COMMENT: JLUDE MAIN

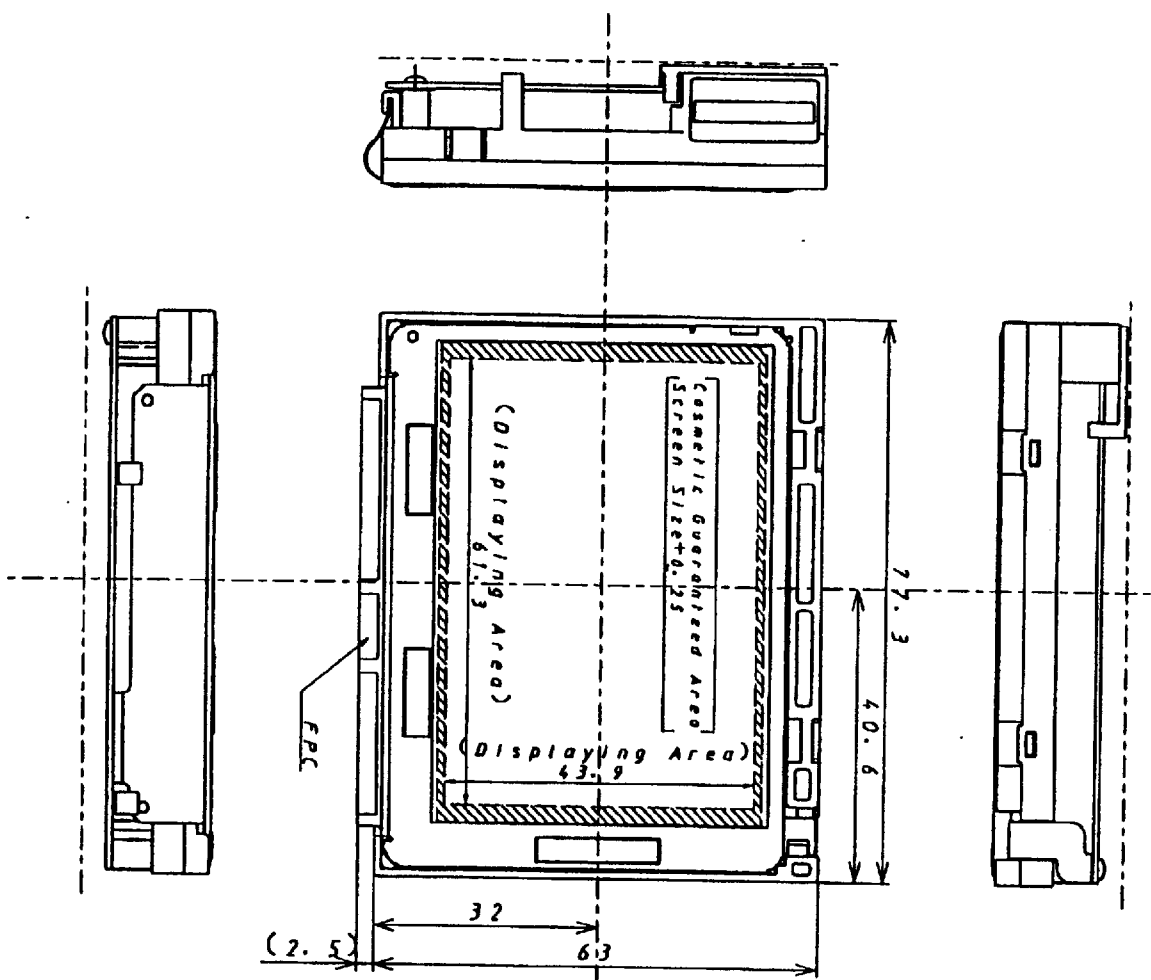

Viewing Angle

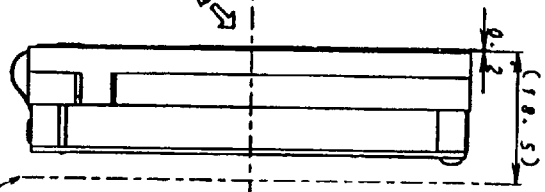

PARTS HEIGHT MAX

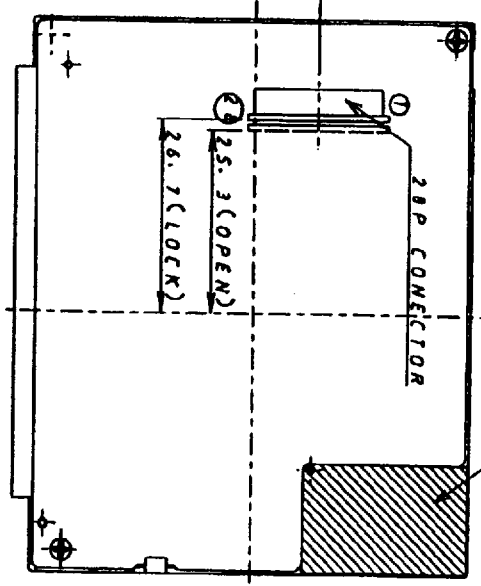

CONNECTOR: PITCH 0.5MM
CONTACT LOWER

3L-U8E

MODEL LABEL

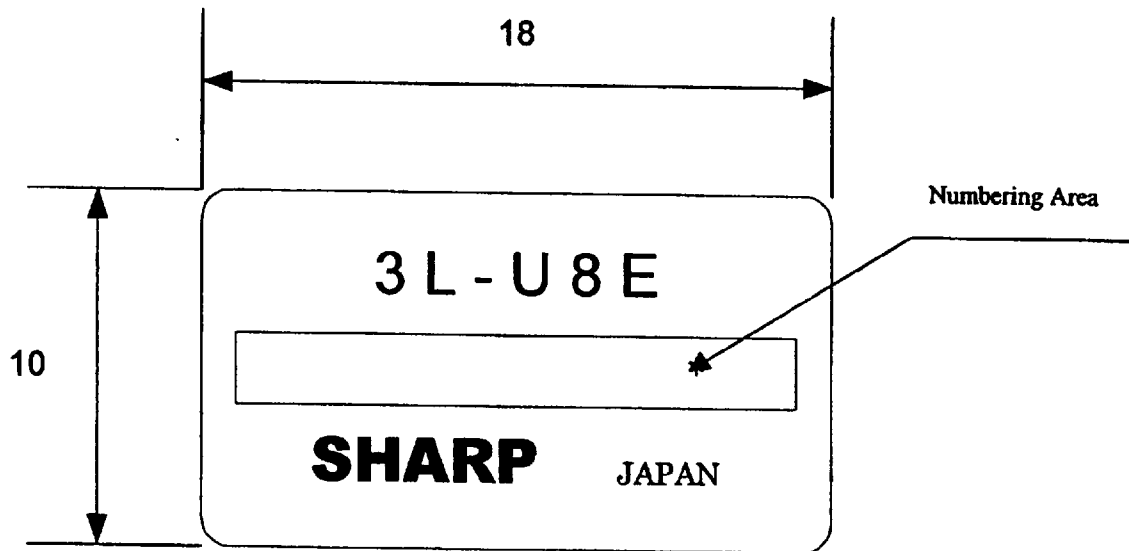

* SERIAL No.

9 DIGIT

EX. : 8 0 4 3 1 1 1 1 2

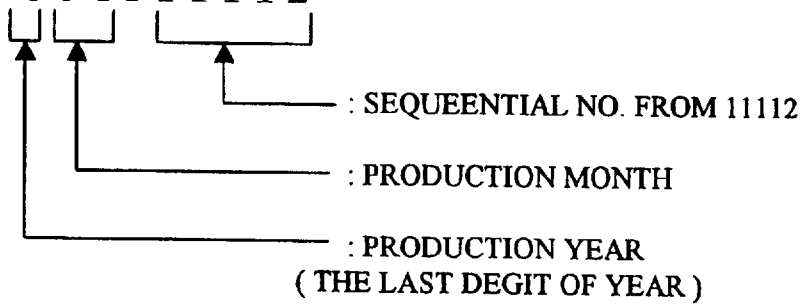

SHARP

パツケージ「ザイン」オーナーズブック

品名	COLOR TFT-LCD CHASSIS UNIT	仕向地	国内・ 輸出 (米 国)	素材	深緑ボール・白緑ボール・コートボール		印刷方法	7レキツ・オフセット・()	
	形名		3L-U8E 色名()		社内・ 社外 (タカハタ)	色数		1色目	3色目
		生産地	海外 ()		墨 1 色	2色目		4色目	

	SHARP 3L-U8E COLOR TFT-LCD CHASSIS UNIT		SHARP 3L-U8E COLOR TFT-LCD CHASSIS UNIT		SHARP 3L-U8E COLOR TFT-LCD CHASSIS UNIT		SHARP 3L-U8E COLOR TFT-LCD CHASSIS UNIT
	SHARP 3L-U8E COLOR TFT-LCD CHASSIS UNIT		SHARP 3L-U8E COLOR TFT-LCD CHASSIS UNIT		SHARP 3L-U8E COLOR TFT-LCD CHASSIS UNIT		SHARP 3L-U8E COLOR TFT-LCD CHASSIS UNIT
	SHARP 3L-U8E COLOR TFT-LCD CHASSIS UNIT		SHARP 3L-U8E COLOR TFT-LCD CHASSIS UNIT		SHARP 3L-U8E COLOR TFT-LCD CHASSIS UNIT		SHARP 3L-U8E COLOR TFT-LCD CHASSIS UNIT

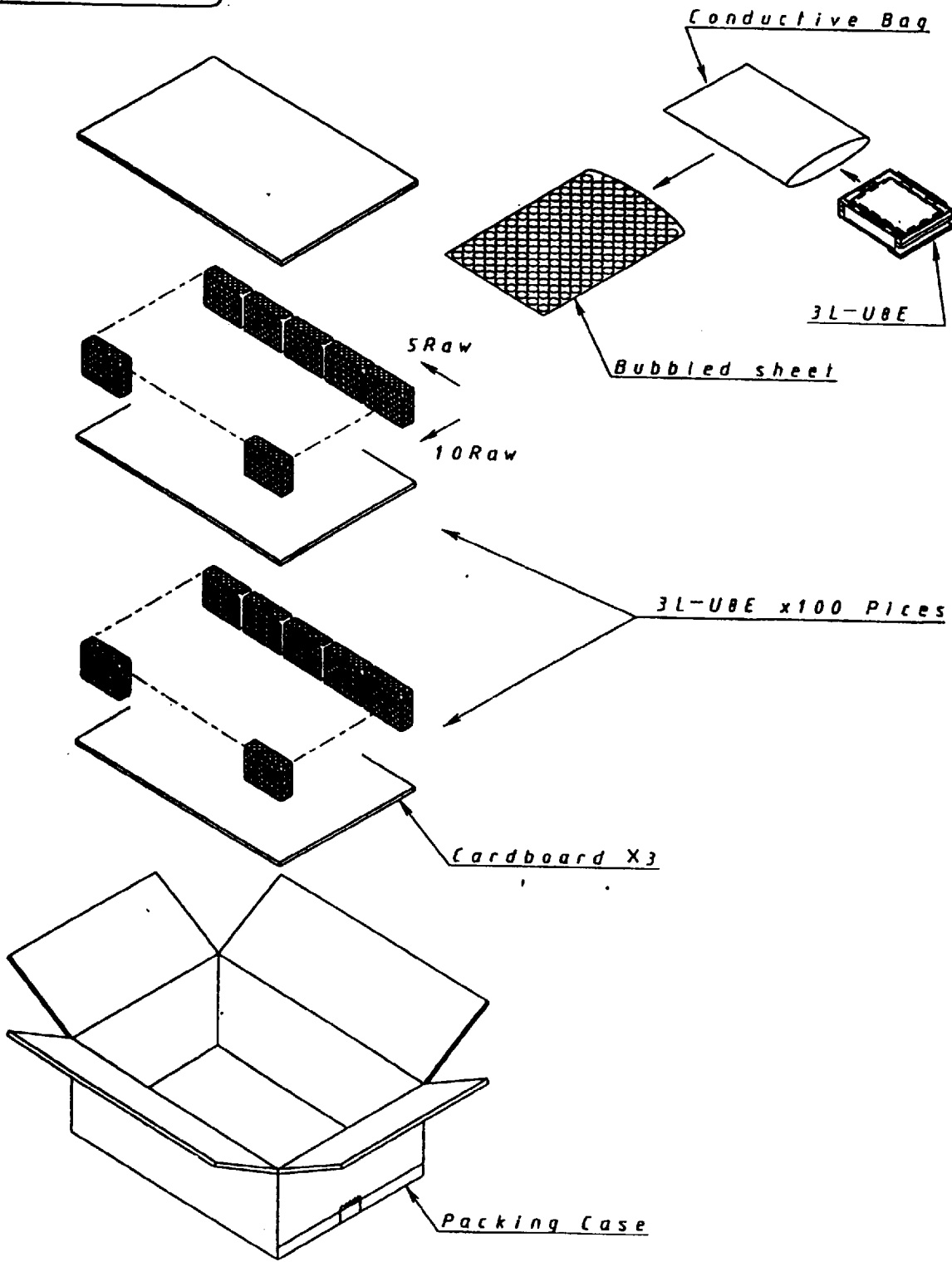

名称 NAME	部品コード PART CODE			△	...		
Packing Specification	3L-U8E			△	...		
材質 MATERIAL	仕上 FINISH	尺貫 SCALE	Free	△	...		
設計 DESIGNED	製図 DRAWN	検図 CHECKED	承認 APPROVED	年月日 DATE	訂正記事 REVISIONS	設通No.	
シャープ株式会社 AVシ(事)AV第1(事)第2技術部 SHARP CORPORATION				適用機種 MODEL	作成日付 DATE		
				#45611	1998. 6. 14		

OUTGOING INSPECTION STANDARD
FOR
MODEL: 3L-U8E

This inspection standard shall be applied for the outgoing inspection effected at the factory of Sharp Corporation on 3 inch Color LCD Display Model 3L-U8E to be supplied to SEC.

1. Inspection Method:

Inspection method is based sampling inspection.

(1) Inspection System:

Sampling inspection is based on ISO 2859 Normal inspection, single sampling, level II.

(2) Lot Size:

Quantity per shipment per model

(3) Acceptable Quality Level(AQL):

The AQL are established for major and minor and defectives separately as follows:

- i) Major defectives: AQL 1.0
- ii) Minor defectives: AQL 2.5

(4) Classification of Defective:

Defective are classified as a major defective and a minor defective according to their seriousness.

i) Major defectives:

A major defective contains one or more major defects and may also contain defects. A major defect is a defect that is likely to result in failure, or to reduce materially the usability of the product for its intended purpose.

ii) Minor defectives:

A minor defective contains one or more minor defects but contains no major defect. A minor defect is a defect that is not likely to reduce materially the usability of the product for its intended purpose, or is a departure from established standards having little bearing on the effective use or operation of the product.

Detail as per the separate table titled "Classification of Defectives", attached.

(5)Judgement of Inspection Result:

If the number of defective sets in the lot is equal to or less than the applicable acceptance number, the lot shall be accepted. On the other hand, if the number of defective set is equal to or more than the applicable rejection number, the lot shall be rejected.

i)Accepted lot:Shipment released.

ii)Rejected lot:100% re-inspection of the lot and necessary corrective measures shall made. Then, the same outgoing inspection shall be made to the lot again.

2 . Items to be Inspected :

- 1-appearance
- 2-Performance
- 3-Display

3 . Inspection Condition:

Unless otherwise stipulated for each inspection, all inspections shall be made with the following inspection conditions.

i)Power Supply : DC 8.0V

ii)Environment : Normal temperature and normal humidity within a room.

JUN. , 24, 1998

DATE



SIGNATURE (H. Nonaka)

Department General Manager

Product Quality Assurance

Department

TV Systems Division. 1

Audio-Visual Systems Group

3 inch color LCD Display Model 3L-U8E Defective Classifications Exterior
--

1. Appearance

NO	Item	Requirements	Judgement Reference	Defective Class			Remarks
				Fatal	Major	Minor	
1.1	•Carton box	•The carton box shall be the one designed exclusively for the pertinent product, and shall be free from damage, incomplete bonding, soil or any other visual flaws.	•Torn damage •Incomplete bonding •Printed information error			○ ○ ○	
1.2	•Serial No. •Label	•Shall have no error, and be free from any visual deficiency.	•Missing label •Error information •Illegible due to surface soil or dirt. •Notable skew or displacement from the normal position.		○ ○	○ ○	
1.3	•External terminal, A connector	•Shall pose no problem in normal connections.	•Proper connection is difficult or disabled.		○		
1.4	•Screw fastening	•There shall be no loose screws or those with damaged screw threads.	•Loose screws •Screws with damaged screw threads		○	○	

2. Performance

NO	Item	Requirements	Judgement Reference	Defective Class			Remarks
				Fatal	Major	Minor	
2.1	Picture	•No appreciable Problem shall be observed in picture quality, focus and others.	•Poor picture quality, poor focus, etc.		○		
2.2	Brightness	•Center areas: More than 300cd/m ²	•Significantly dark •Brightness More than 200cd/m ²		○	○	
2.3	Synchroni- zation	•Both horizontal and vertical synchronization shall be normal.	•Off-synchroni- zation(V jitter, pull-in, sustain or other faults)		○		
2.4	R•G•B Input	•Shall function operate normally.	•Defective function		○		
2.5	Shock noise	•Shall produce no visual or audible noise or any other malfunction when the unit sustained physical shock or vibration.	•Noise or malfunction.		○		
2.6	Unusual noise	•No unusual noise shall be heard from the unit.	•Noise beyond usability •Annoying but within usability		○	○	
2.7	Power consumption	•DC 8.0V 3.2W±20%	•Power consumption outside the specified		○		

3.Display

3-1.Classification of defect

a)Major defect

•Function defect

Abnormal operation including distinct R,G,B line defects and or white line defect

b)Minor defect

- ① Dot Defect
- ② Display non-uniformity
- ③ Vertical stripes
- ④ An afterimage
- ⑤ Extraneous substances
- ⑥ Scratches
- ⑦ Dents
- ⑧ Current dissipation

3-2.Bright dots

[Inspection Condition]

•Visual inspection

Viewing distance ... $350 \pm 50\text{mm}$
 Ambient illumination ... $100 \sim 150\text{Lux}$
 Ambient temperature ... $20 \sim 25^\circ\text{C}$
 Light source Condition ... $3000 \pm 500\text{nt}$

•Viewing angle ...

The surface of the MODULE and the eyes of the inspector shall be 90 degrees.

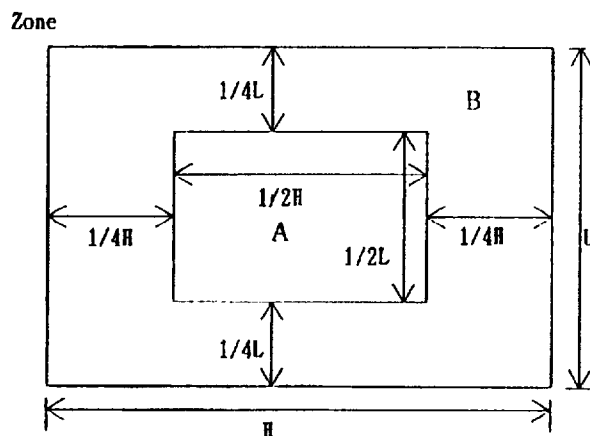

[Standards(Acceptable)]

- Green/Red/Blue dots : When the MODULE light,dots appear bright in display at dark picture position

Dot \ Zone	A	B	Total	
Green/Red/Blue	High level	2	3	4
	Low level	2	5	8
Total		4	8	9

a)Bright dots

High level : Visible through 3% Transparency of filter(Only Red,Green)

Low level : Not Visible through 3% Transparency of filter(Red,Green,Blue)

No count : Not visible through 10% Transparency of filter

b)Scratches on the color filter

Count : Visible over the half of a dot

No count : Visible under the half of a dot

c)Scratches on the Cr. mask

•Count : Visible over 50 μm

•No count : Visible under 50 μm

e)Defect distance

•High and High level(Red,Green) : 15mm Min.

•High and Low level (Red,Green,Blue) : 5mm Min.

•Low and Low level : 5mm Min.

3-3.Black dots

- Black dots : When the MODULE lights,dots appear black in display at white pictuer position.

ZONE	A	B	Total
Black	2	6	8

a)2dots join : lcount

b)Defect distannce : 5mm Min.

3-4.Display non-uniformity

There should be no distinct non-uniformity visible through 3% transparency of filter.

- Viewing distance ... 350 \pm 50mm
- Ambient illumination ... 100~150Lux
- Ambient temperature ... 20~25 $^{\circ}$ C
- Viewing angle ...

The surface of the MODULE and the eyes of the inspector shall be 90 degrees.

3-5.An afterimage(Acceptable level)

After displaying same pattern for 5 seconds afterimage disappears within 10 seconds.

3-6.External

Quantities=N,Average Diameter=D(mm),Length=L(mm)

Items to be inspected	Inspection standards (Acceptable level)	
Extraneous substances	Black spots	Black spots which appears when operating $0.1 \leq D \leq 0.5$ $N \leq 2$
	Lint	Lint which appear when operating $3.0 \geq L$ $N \leq 2$
Scratches		Scratches on the polarizer $10.0 \geq L$ $N \leq 3$
Dent		Dent on the polarizer $0.1 \leq D \leq 0.5$ $N \leq 3$

NOTE: The external visual inspection

The inspection shall be conducted by using a single 20W fluorescent lamp for illumination and the distance between the MODULE and the inspector shall be 35cm or more.

003-100

3L-U8E Electrical Interface Requirements

The following describes electrical requirements and precautions for the 3L-U8E LCD Module.

1. Using Composite Video Input

- Use connector pins A18 and A17 (GND) for composite video input
- Set pin A10 (Ys signal) to Low (GND) level .

2. Using Analog RGB Inputs

- Use connector pins A11 – A16, A6, and A7 for analog RGB input.
- For horizontal and vertical synchronization, apply a composite H/V sync. signal (Negative polarity TTL level) to pin A7.

When separate H. and V. synchronization signals are desired, consult us.

- A high level (5.3V) signal should be applied to the Ys signal input (pin A10).

3. Using Superimposed Video Signals

- The composite and RGB video signals should be synchronized with each other
- Use connector pins A11 through A16 for RGB video inputs, and pins A18 and A17 for composite video inputs.
- Set pin A9 (S/I ON signal) to Low (GND) level to make the composite synchronization signal active.
- RGB is selected when the Ys (pin A10) is set high.

4. Controlling Color, Tint, and Brightness (pins A23, A21, and A22)

- The following voltage ranges are typically recommended for color, Tint, and brightness control:

	Pin #	Center Voltage	Voltage range
Color	A23	3.0 V	0 - 4.8 V
Tint	A21	3.1 V	1.0 - 4.8 V
Brightness	A22	3.0 V	2.5 - 4.0 V

CAUTION) Keep the voltage applied to Brightness above 2.5V.

5. Dimming Control Voltage

- The voltage applied to pin A20 should range from 2.0 to 4.6V volts. (Maximum brightness is at 2.0V and minimum brightness at 4.6V [around 15% of the maximum brightness]).

CAUTION) Keep the voltage applied to pin A20 below 4.6V. Otherwise the display may flash.

6. Fuse

- The following fuse is being applied as protective components. Please apply specified fuse for the safety in the case fuse is blew out. F751 ; protect for Lamp drive line.

Fuse type : Rated current 630mA rms., Slow blow type
manufacture name SOC Corporation
type no. SSTC- 630 mA
UL recognized No. E39265

F701 ; protect for video circuit line.

Fuse type : Rated current 800 mA rms., Slow blow type

manufacture name SOC Corporation

type no. SSTC- 800 mA

UL recognized No. E39265

7. Connector Pin Assignments

External Connector

Connector		
A1		GND (for Inverter)
A2		+8 V Input (for Inverter)
A3		+8 V Input (for Inverter)
A4		+8 V Input (for Signal Circuit)
A5		GND (for Signal Circuit)
A6		C-Sync GND
A7		C-Sync Input (Analog RGB signal)
A8		N.C.
A9		Super Impose
A10		Ys Input
A11		RGB GND
A12		Blue Signal Input (Analog RGB signal)
A13		RGB GND
A14		Green Signal Input (Analog RGB signal)
A15		RGB GND
A16		Red Signal Input (Analog RGB signal)
A17		Video GND
A18		Video Input (NTSC Composite video signal)
A19		GND
A20		Dimming adjustment signal
A21		Tint adjustment signal
A22		Brightness adjustment signal
A23		Color adjustment signal
A24		Vertical image reverse setting
A25		Horizontal image reverse setting
A26		+5.0 V OUTPUT
A27		V-SYNC OUTPUT (Internal Vertical sync. signal)
A28		H-SYNC OUTPUT (Internal horizontal sync. signal)

Connector manufacture Molex

Connector name 52435-2891
0.5 mm pitch 28 poles
Contact side upper

8. Miscellaneous

- Supply Input

The 3L-U8E requires two separate power supply systems for signal processing (pins A4, A5) and the DC/AC inverter (A1, A2, A3).

Separate voltage regulators should be used for the two power supply systems as follows:

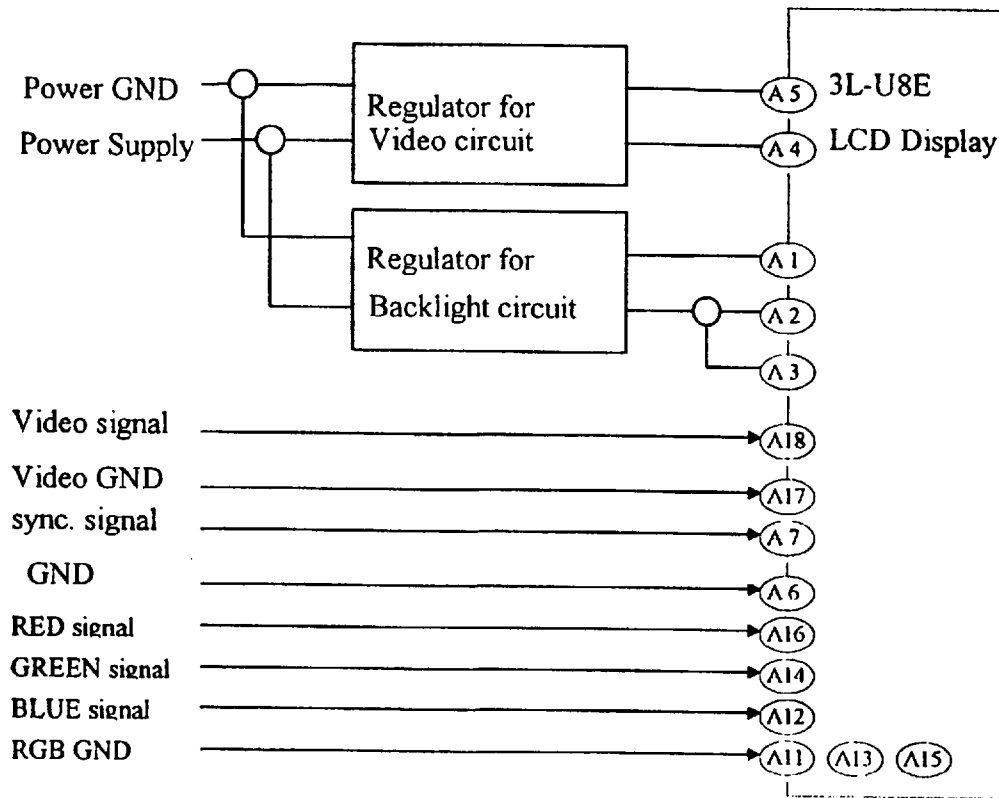

Connect the grounds for the two supply systems. Otherwise, display images may be disturbed by beat caused by supply ripple.

- Input signal timing

Do not activate control signals before the supply voltages have stabilized for the signal processing and inverter circuits. Otherwise, the circuit may be damaged by latch-up.

- +5.0V DC output

The +5.0 VDC output at pin A26 may be used for brightness, color, tint, and dimmer adjustment. The current capacity is 10 mA max.

Note) The content of this information is subject to change without prior notice.

25

9. RECOMMENDED ADJUST CIRCUIT

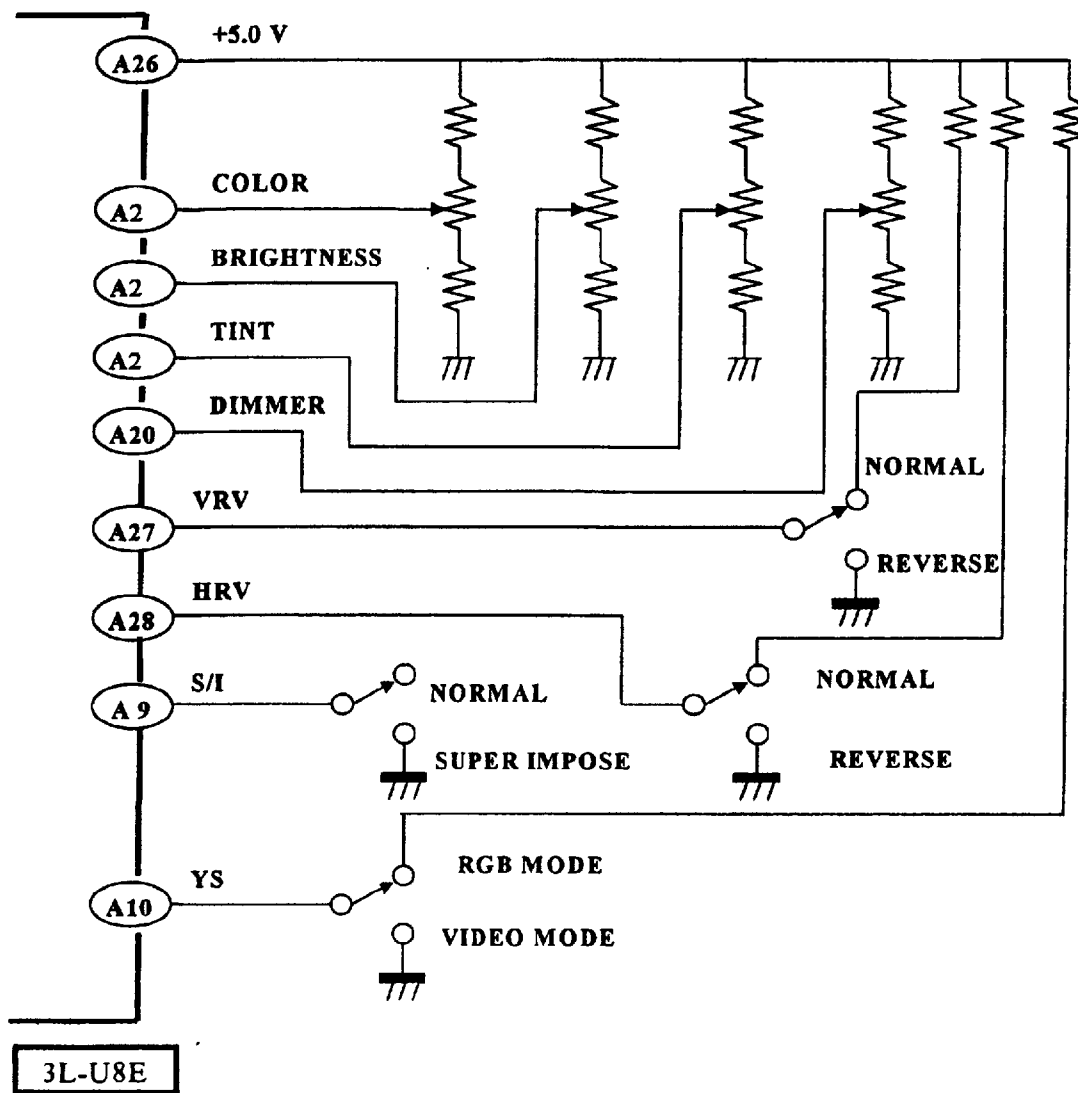

3L-U8E Block Diagram

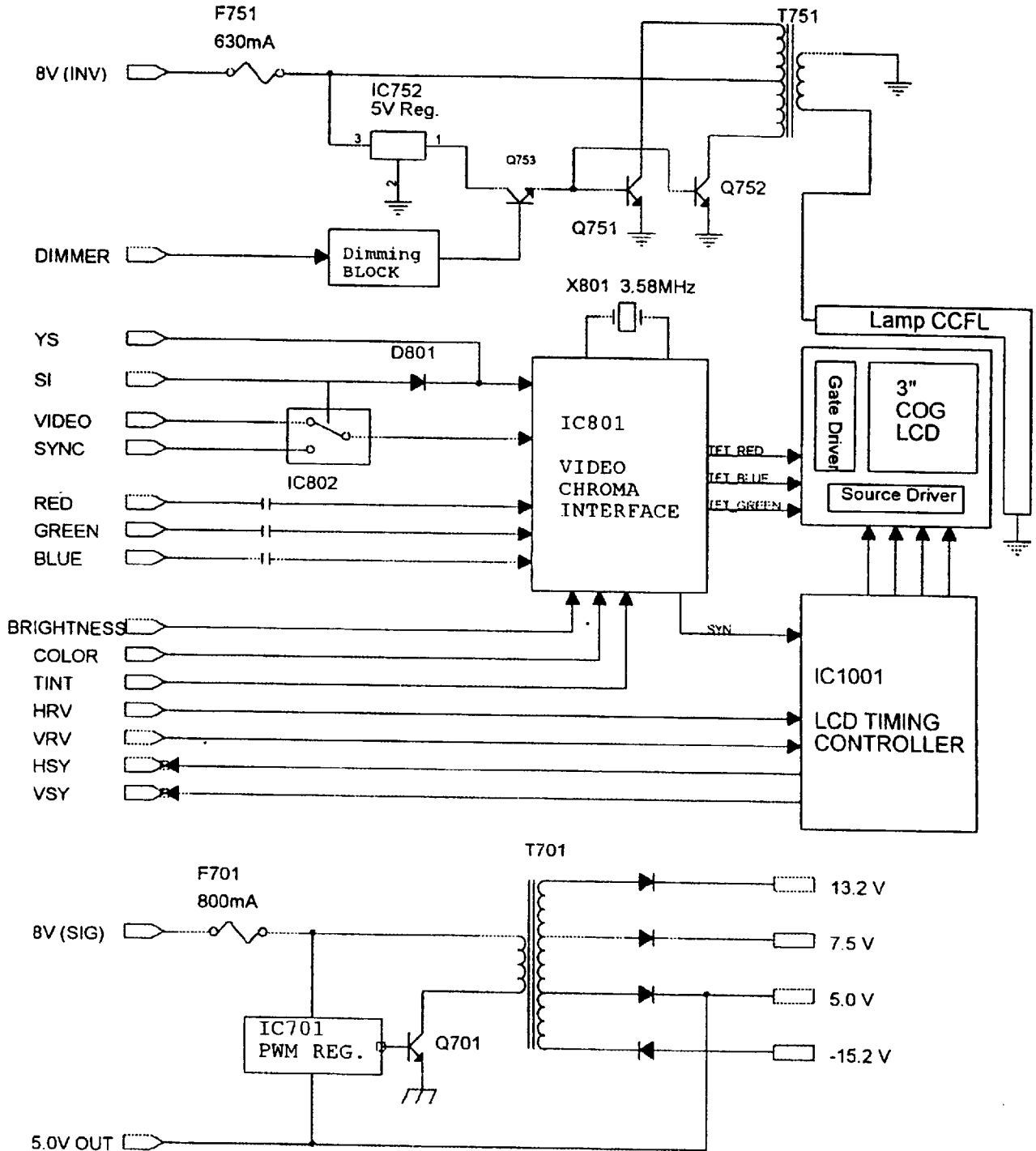

27

3L-U8E スーパーインポーズ回路例 (On Screen Display)

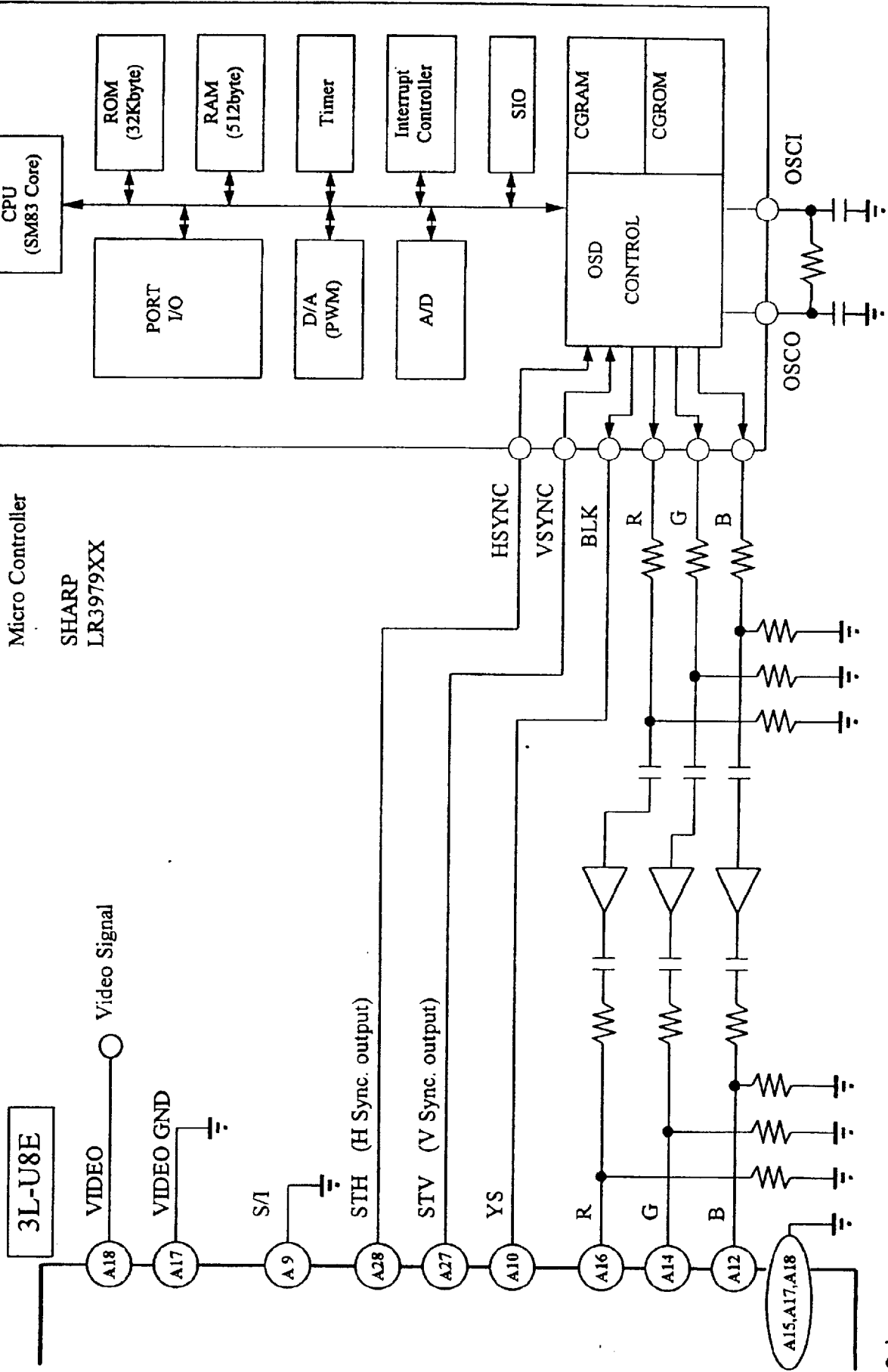

3L-U8E HANDLING PRECAUTIONS

1. Cable Connection

- 1) Turn off the power to the LCD Display before connecting or disconnecting a cable.

2. Installation

- 1) When the LCD Monitor panel is to be installed directly on the equipment's surface, use the panel's metallic area for installation. If the panel surface is in direct contact with the equipment surface, the resulting stress may damage the panel or cause it to deteriorate.
- 2) In case that no protective plate is attached on the panel surface, pay attention to the following points. In order to avoid the electrostatic discharge, design the cabinet with grounded conductive sheet inside and cover the module include edge of the polarizer with it.

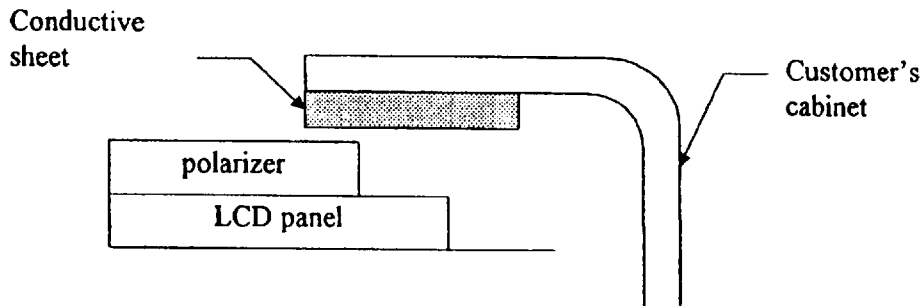

3. Cautions for Installation

- 1) Handling the polarizing plate requires the utmost care, as it is easily damaged.
- 2) Installation working Environment

To prevent damage from static electricity, the following working environment is recommended:

- The floor should have a conductive surface (conductive mat or paint) or more than $1\text{M } \Omega$ resistance.
- The room should be isolated from the outdoor air, and have an adhesive mat at its entrance to clean shoes.
- The ambient atmosphere should be 15 to $27\text{ }^\circ\text{C}$, 50% to 70% RH.
- The operator should wear conductive shoes, conductive work clothes, conductive gloves, and grounding wrist straps.

3) Cleaning dust off the polarizing plate surface

- Blow dust off the polarizing plate surface with an N₂ blower with anti-static treatment. Use of an ionized air gun (from Hugel Electronics co.) is recommended.
 - The polarizing plate surface is so sensitive that it should not be wiped with a cleaning cloth. If it gathers dust, use adhesive plastic tape to pick it up.
- 4) Contaminants on the shield casing or other metallic areas should be wiped off with a soft, dry cloth.
 - 5) Water drips or fingerprints, if left on the panel surface for long time period, may cause discoloration or spots. They should be cleaned off as soon as possible.
 - 6) The LCD panel is made of glass. Carefully protect it from hard jolts.
 - 7) The LCD module uses CMOS ICs. Operators should properly ground themselves to prevent possible electrostatic damage.

4. Precautions for Alignment

The LCD module and its driver board are adjusted as an integrated unit. If either the module or the driver board is replaced, readjustment will be required. Miss alignment will do harm to performance and / or reliability.

5. Miscellaneous

- 1) Do not leave the LCD panel in direct sunlight or strong ultraviolet light for very long.
- 2) At temperatures below the rated storage temperature, the liquid crystal inside the panel may be freeze and damage the cells. At temperatures above the rated storage temperature, the liquid crystal may irreversibly turn into an isotropic liquid. We strongly advise that the LCD panel be stored at close to normal room temperature.
- 3) If the LCD panel is cracked and the liquid within spills, take care not to swallow it. If your hands or clothing become stained with the liquid, immediately clean it off with soap and water.
- 4) Do not let the monitor constantly display a fixed image for long time, as it may leave an afterimage. In the worst case, the liquid crystal may suffer permanent burn-in damage.
- 5) Also observe general precautions for handling electronic parts.

6. Insulation distance at high voltage parts.

The following components / pattern at lamp driving circuit have high voltage.
(approx. 2K V p-p).

Therefore, please do not mount any metal within 4mm from these components / pattern.

- Line : T751 ~ LAMP

Note) The content of this section is subject to change without prior notice.

Model: 3L-U8E

Non-flammability list for main parts of 3L-U8E

No	Item	Parts Code	Parts	Materials Supplier	Type	Non-flammability class	Remarks
1	LCD Module holder	LHLDZ2094CEZZ	PC+ABS	Idemitsu Petrochemical Co., Ltd	SN280	94V-0	
2	Light guide holder	LHLDZ2095CEZZ	PC	Mitsubishi Engineering-Plastic Co., Ltd	HR-3001NR	94V-0	
3	Insulation sheet	LHLDZ2096CEZZ	PC+ABS	Idemitsu Petrochemical Co., Ltd	SN280	94V-0	
4	Light guide	PGIDM0048CEZZ	Acrylite	Mitsubishi Rayon Co. Ltd.	Acrylite LN865	94HB	with printing
5	PWB	QKITP934CETS		Matsushita Denko Co., Ltd.	GCMK-C1X	94V-0	

Remark

Insulation sheet: black sheet for high voltage protection

Note

There are no caution about fuse replacement & fuse symbol in PWB, which is regulated by UL.

In the case Magellan get UL approval for the products mounted on 3L-U8E, followings are necessary.

- a) To paste fuse label
- b) To describe cautioning about fuse replacement in Magellan's service manual.

USER: TVH5
OUTPUT TIME: 11-JUN-1998 10:30:20 COMMENT: 3LU8E MAIN

3L-U8E

