

**SMALL SIGNAL COMBINATION IC FOR COLOUR TV****GENERAL DESCRIPTION**

The integration into a single package of all small-signal functions required for colour tv reception is achieved in the TDA4501. The only additional circuits needed to complete the receiver are a tuner, the deflection output stages and a colour decoder.

The IC includes a vision IF amplifier with synchronous demodulator and AFC circuit; an AGC detector with tuner output; an integral three-level sandcastle pulse generator; and fully synchronized vertical and horizontal drive outputs. A triggered vertical divider automatically adapts to 50 or 60 Hz working and eliminates the need for an external vertical frequency control.

Signal-strength dependent time-constant switches in the horizontal phase detector make external VCR switching unnecessary.

Sound signals are demodulated and amplified within the IC in a circuit which includes volume control and muting.

**Features**

- Vision IF amplifier with synchronous demodulator
- AGC detector for negative modulation
- AGC output to tuner
- AFC circuit
- Video and audio preamplifiers
- Sound IF amplifier and demodulator
- Choice of sound volume control or horizontal oscillator starting function
- Horizontal synchronization circuit with two control loops
- Triggered divider system for vertical synchronization and sawtooth generation giving automatic amplitude adjustment for 50 or 60 Hz working
- Transmitter identification circuit with mute output
- Sandcastle pulse generator

**QUICK REFERENCE DATA**

Supply voltage	V <sub>7-6</sub>	typ.	10,5 V
Supply voltage	V <sub>11-6</sub>	typ.	10,5 V
Operating ambient temperature range	T <sub>amb</sub>	-25 to +65	°C
Storage temperature	T <sub>stg</sub>	-25 to +150	°C
Power dissipation	P <sub>tot</sub>	max.	1,7 W

**PACKAGE OUTLINE**

28-lead DIL; plastic (with internal heat spreader) (SOT117).

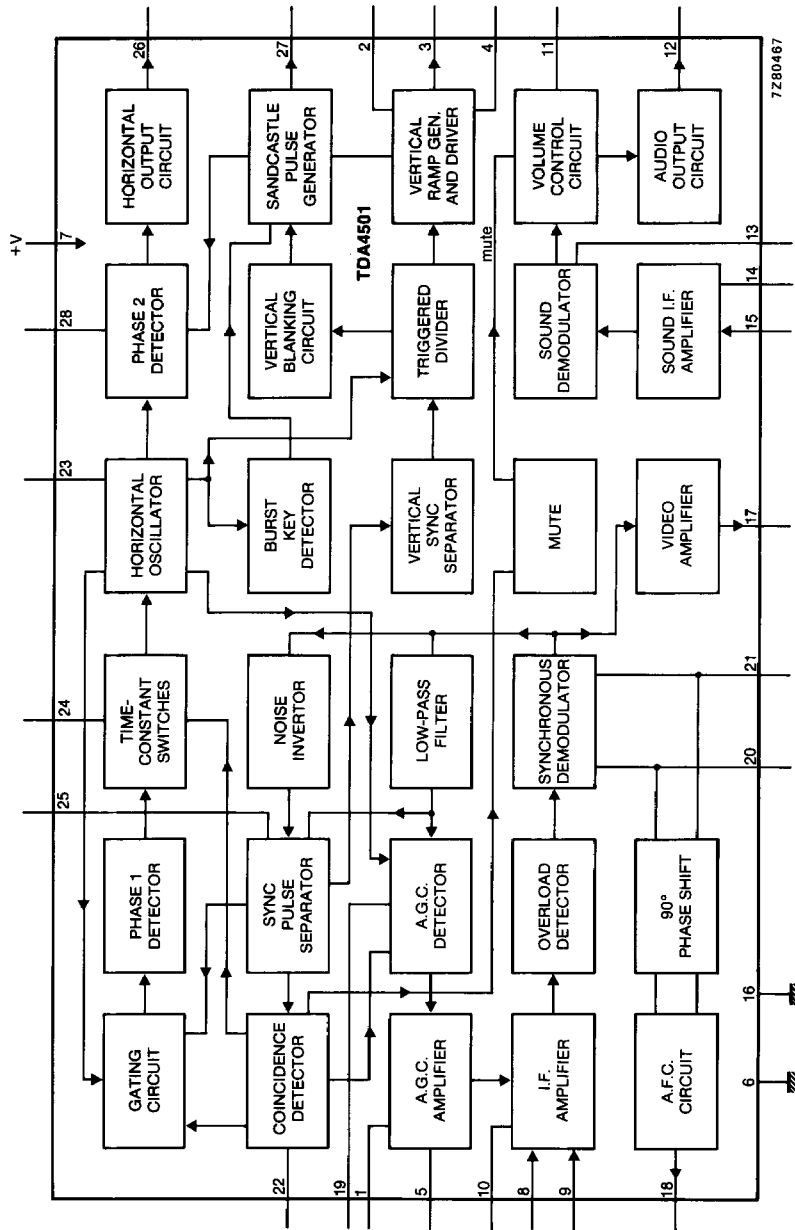

Fig. 1 Block diagram.

**PINNING**

- |                                    |                                     |
|------------------------------------|-------------------------------------|
| 1. AGC take over                   | 15. Sound IF input                  |
| 2. Ramp generator                  | 16. Ground                          |
| 3. Vertical drive                  | 17. Video output                    |
| 4. Vertical feedback               | 18. AFC                             |
| 5. Tuner AGC                       | 19. AGC detection                   |
| 6. Ground                          | 20. Sync demodulator                |
| 7. Supply                          | 21. Sync demodulator                |
| 8. IF input                        | 22. Coincidence detector decoupling |
| 9. IF input                        | 23. Horizontal oscillator           |
| 10. Decoupling capacitor           | 24. Frequency control               |
| 11. Volume control/start Hor. osc. | 25. Sync separator                  |
| 12. Audio output                   | 26. Horizontal drive                |
| 13. Sound demodulator              | 27. Sandcastle out/flyback in       |
| 14. Sound IF decoupling            | 28. Phase detection                 |

**FUNCTIONAL DESCRIPTION****IF amplifier, demodulator and AFC**

The IF amplifier has a symmetrical input (pins 8 and 9), the input impedance of which is suitable for SAW-filtering to be used. The synchronous demodulator and the AFC circuit share an external reference tuned circuit (pins 20 and 21). An internal RC-network provides the necessary phase-shifting for AFC operation. The AFC circuit provides a control voltage output with a swing greater than 9 V from pin 18.

**AGC circuit**

Gating of the AGC detector is performed to reduce sensitivity of the IF amplifier to external electrical noise. The AGC time constant is provided by an RC-circuit connected to pin 19. Tuner AGC voltage is supplied from pin 5 and is suitable for tuners with p-n-p or n-p-n RF stages. The sense of the AGC (to increase in a positive or negative direction) and the point of tuner take-over are preset by the voltage level at pin 1.

**Video amplifier**

The signal through the video amplifier comprises video and sound information, therefore no gating of the video amplifier is performed during flyback periods.

**Sound circuit and horizontal oscillator starting function**

The input to the sound IF amplifier is obtained by a bandpass filter coupling from the video output (pin 17). The sound is demodulated and passed via a dual-function volume control stage to the audio output amplifier. The volume control function is obtained by connecting a variable resistor (10 k $\Omega$ ) between pin 11 and ground, or by supplying pin 11 with a variable voltage. Sound output is suppressed by an internal mute signal when no input signal is present.

The horizontal oscillator starting function is obtained by supplying pin 11 with a current of 6 mA during the switching-on period. The IC then uses this current to generate drive pulses for the horizontal deflection. For this application, the main supply voltage for the IC can be obtained from the horizontal deflection circuit.

**FUNCTIONAL DESCRIPTION (continued)****Vertical divider system**

A triggered divider system is used to synchronize the vertical drive waveforms, adjusting automatically to 50 or 60 Hz working. A large window (search window) is opened between counts of 488 and 722; when a separated vertical sync pulse occurs before count 576, the system works in the 60 Hz mode, otherwise 50 Hz working is chosen.

A narrow window is opened when 15 approved sync pulses have been detected. Divider ratio between 522 and 528 switches to 60 Hz mode; between 622 and 628 switches to 50 Hz mode.

The vertical blanking pulse is also generated via the divider system by adding the anti-topflutter pulse and the blanking pulse.

**Line phase detector**

The circuit has three operating conditions:

- a. Strong input signal and synchronized.
- b. Weak signal and synchronized.
- c. Non synchronized (weak and strong) signal.

The input signal condition is obtained from the AGC circuit.

**D.C. volume control/horizontal oscillator start**

The operation depends on the application. When during switch-on no current is supplied pin 11 will act as volume control. When a current of 6 mA is applied the volume control is set to maximum and the circuit will generate drive pulses for the horizontal deflection.

**RATINGS**

Limiting values in accordance with the Absolute Maximum System (IEC 134)

Supply voltage (pin 7)	$V_p = V_{7-6}$	max.	13,2 V
Total power dissipation	$P_{tot}$	max.	1,7 W
Operating ambient temperature range	$T_{amb}$		-25 to + 65 °C
Storage temperature range	$T_{stg}$		-25 to + 150 °C

## CHARACTERISTICS

 $V_p = V_{7-6} = 10,5 \text{ V}$ ;  $T_{\text{amb}} = 25 \text{ }^\circ\text{C}$ ; unless otherwise specified

DEVELOPMENT DATA

parameter	symbol	min.	typ.	max.	unit
<b>Supplies</b>					
Supply voltage (pin 7)	V <sub>7-6</sub>	9,5	10,5	13,2	V
Supply current (pin 7)	I <sub>7</sub>	—	120	—	mA
Supply voltage (pin 11)	V <sub>11-6</sub>	—	10,5	—	V
Supply current (pin 11) for horizontal oscillator start	I <sub>11</sub>	—	6	—	mA
<b>Vision IF amplifier (pins 8 and 9)</b>					
Input sensitivity at 38,9 MHz (note 1)	V <sub>8-9</sub>	40	70	120	$\mu\text{V}$
Input sensitivity at 45,75 MHz (note 1)	V <sub>8-9</sub>	—	90	—	$\mu\text{V}$
Differential input resistance (pin 8 to 9)	R <sub>8-9</sub>	—	1,3	—	k $\Omega$
Differential input capacitance (pin 8 to 9)	C <sub>8-9</sub>	—	5	—	pF
AGC range		—	60	—	dB
Maximum input signal	V <sub>8-9</sub>	50	70	—	mV
Expansion of output signal for 50 dB variation of input signal with V <sub>8-9</sub> at 150 $\mu\text{V}$ (0 dB)	$\Delta V_{17-6}$	—	1	—	dB
<b>Video amplifier</b>					
Output level for zero signal input (zero point of switched demodulator)	V <sub>17-6</sub>	—	4,5	—	V
Output signal top sync level (note 2)	V <sub>17-6</sub>	—	1,4	—	V
Amplitude of video output signal (peak-to-peak value)	V <sub>17-6(p-p)</sub>	—	2,8	—	V
Internal bias current of output transistor (n-p-n emitter follower)	I <sub>17(int)</sub>	1,4	2,0	—	mA
Bandwidth of demodulated output signal	B	—	6	—	MHz
Differential gain (Fig. 4)	G <sub>17</sub>	—	6	—	%
Differential phase (Fig. 4)		—	4	—	%
Video non-linearity complete video signal amplitude		—	—	10	%
Intermodulation (Fig. 5) at gain control = 45 dB					
f = 1,1 MHz; blue;		55	60	—	dB
f = 1,1 MHz; yellow;		50	54	—	dB
f = 3,3 MHz; blue;		60	66	—	dB
f = 3,3 MHz; yellow		55	59	—	dB

## CHARACTERISTICS (continued)

parameter	symbol	min.	typ.	max.	unit
<b>Video amplifier (continued)</b>					
Signal to noise ratio (note 3)					
$Z_S = 75 \Omega$					
$V_i = 10 \text{ mV}$	S/N	50	54	—	dB
end of gain control range	S/N	50	56	—	dB
Residual carrier signal		—	7	30	mV
Residual 2nd harmonic of carrier signal		—	3	30	mV
<b>Tuner AGC *</b>					
Take-over voltage (pin 1 for positive-going tuner AGC (NPN tuner))	$V_{1-6}$	—	3,5	—	V
Starting point take over; $V = 5 \text{ V}$	$V_{1-6}(\text{rms})$	—	0,4	2	mV
Starting point take over; $V = 1,2 \text{ V}$	$V_{1-6}(\text{rms})$	50	70	—	mV
Take-over voltage (pin 1) for negative-going tuner AGC (PNP tuner)	$V_{1-6}$	—	8	—	V
Starting point take over; $V = 9,5 \text{ V}$	$V_{1-6}(\text{rms})$	—	0,3	2	mV
Starting point take over; $V = 5,6 \text{ V}$	$V_{1-6}(\text{rms})$	50	70	—	mV
Maximum output swing	$I_5 \text{ max}$	2	3	—	mA
Output saturation voltage $I = 2 \text{ mA}$	$V_{5-6}(\text{sat})$	—	—	300	mV
Leakage current	$I_5$	—	—	1	$\mu\text{A}$
Input signal variation complete tuner control	$\Delta V_i$	0,5	2	4	dB
<b>AFC circuit (pin 18; note 4)</b>					
AFC output voltage swing	$V_{18-6}(\text{p-p})$	9	—	10	V
Available output current	$\pm I_{18}$	—	1	—	mA
Control steepness					
—100% picture carrier		20	40	80	mV/kHz
—10% picture carrier		—	15	—	mV/kHz
Output voltage at nom. tuning of the reference tuned circuit	$V_{18-6}$	—	5,25	—	V
Output voltage without input signal	$V_{18-6}$	2,7	5,25	8,5	V

\* Starting point tuner take-over NPN current 1,8 mA; PNP tuner  $I = 0,2 \text{ mA}$ .

DEVELOPMENT DATA

parameter	symbol	min.	typ.	max.	unit
<b>Sound circuit</b>					
Input limiting voltage $V_o = V_o \text{ max. } -3 \text{ dB; } Q_L = 16$ $f_{AF} = 1 \text{ kHz; } f_c = 5,5 \text{ MHz}$	V15lim	—	400	—	$\mu\text{V}$
Input resistance $V_i(\text{rms}) = 1 \text{ mV}$	R15-6	—	2,6	—	$\text{k}\Omega$
Input capacitance $V_i(\text{rms}) = 1 \text{ mV}$	C15-6	—	6	—	pF
AM rejection (Figs 8 and 9) $V_i = 10 \text{ mV}$	AMR	—	35	—	dB
$V_i = 50 \text{ mV}$	AMR	—	43	—	dB
AF output signal $\Delta f = 7,5 \text{ kHz; min. distortion}$	V12-6(rms)	220	320	—	mV
AF output impedance	Z12-6	—	150	—	$\Omega$
Total harmonic distortion $\Delta f = 27,5 \text{ kHz}$	THD	—	1	—	%
Ripple rejection $f_k = 100 \text{ Hz, volume control } 20 \text{ dB}$ when muted	RR	—	22	—	dB
	RR	—	26	—	dB
Output voltage mute condition	V12-6	—	2,6	—	V
Signal to noise ratio weighted noise (CCIR 468)	S/N	—	47	—	dB
<b>Volume control</b>					
Voltage (pin 11 disconnected)	V11-6	—	4,8	—	V
Current (pin 11 short circuited)	I11	—	1	—	mA
External control resistor	R11-6	—	10	—	$\text{k}\Omega$
Suppression output signal during mute condition		—	66	—	dB
<b>Horizontal synchronization</b>					
Slicing level sync separator		—	30	—	%
Holding range PLL		800	1100	1500	Hz
Catching range PLL		600	1000	—	Hz
<b>Control sensitivity</b>					
video to oscillator; at weak signal		—	2	—	$\text{kHz}/\mu\text{s}$
at strong signal during scan		—	3	—	$\text{kHz}/\mu\text{s}$
during vert. retrace and during catching		—	6	—	$\text{kHz}/\mu\text{s}$

## CHARACTERISTICS (continued)

parameter	symbol	min.	typ.	max.	unit
<b>Second control loop (positive edge)</b>					
Control sensitivity	$\Delta t_d / \Delta t_0$	—	300	—	$\mu s$
Control range	$t_d$	—	25	—	$\mu s$
Phase adjustment via second control loop; control sensitivity		—	25	—	$\mu A / \mu s$
Maximum allowed phase shift		—	$\pm 2$	—	$\mu s$
<b>Horizontal oscillator (pin 23)</b>					
Free running frequency R = 35 k $\Omega$ ; C = 2,7 nF	$f_{fr}$	—	15625	—	Hz
Spread with fixed external components		—	—	4	%
Frequency variation due to change of supply voltage from 8 to 12 V	$\Delta f_{fr}$	—	0	0,5	%
Frequency variation with temperature	$\Delta f_{fr}$	—	—	$1 \times 10^{-4}$	K <sup>-1</sup>
Maximum frequency shift	$\Delta f_{fr}$	—	—	10	%
Maximum frequency deviation (V <sub>7.6</sub> = 8 V)	$\Delta f_{fr}$	—	—	10	%
<b>Horizontal output (pin 26)</b>					
Output voltage high	V <sub>26-6</sub>	—	—	13,2	V
Output voltage at which protection commences	V <sub>26-6</sub>	—	—	15,8	V
Output voltage low at I <sub>26</sub> = 10 mA	V <sub>26-6</sub>	—	0,3	0,5	V
Duty cycle of horizontal output signal	$\delta_0$	—	45	—	%
Rise and fall times of output pulse	$t_r, t_f$	—	150	—	ns
<b>Flyback input and sandcastle output</b>					
Input current required during flyback pulse	I <sub>27</sub>	0,1	—	2	mA
Output voltage during burst key pulse	V <sub>27-6</sub>	7,5	—	—	V
Output voltage during horizontal blanking	V <sub>27-6</sub>	3,5	4,0	4,5	V
Output voltage during vertical blanking	V <sub>27-6</sub>	1,8	2,2	2,6	V
Width of burst key pulse		3,1	3,5	3,9	$\mu s$
Width of horizontal blanking pulse		flyback pulse width			
Width of vertical blanking pulse					
50 Hz working		—	21	—	lines
60 Hz working		—	17	—	lines
Delay between start of sync pulse at video output and rising edge of burst key pulse		—	5,2	—	$\mu s$



parameter	symbol	min.	typ.	max.	unit
<b>Coincidence detector mute output (pin 22)</b>					
Voltage for in-sync condition	V <sub>22-6</sub>	—	9,5	—	V
Voltage for no-sync condition no signal	V <sub>22-6</sub>	—	1,0	1,5	V
Switching level to switch phase detector from slow to fast	V <sub>22-6</sub>	4,9	5,3	5,8	V
Fast-to-slow hysteresis		—	1	—	V
Switching level to activate mute function (transmitter identification)	V <sub>22-6</sub>	2,25	2,5	2,75	V
Output current for in-sync condition (peak-to-peak value)	I <sub>22(p-p)</sub>	0,7	1,0	—	mA
<b>Vertical ramp generator (pin 2)</b>					
Input current during scan	I <sub>2</sub>	—	12	—	μA
Discharge current during retrace	I <sub>2</sub>	—	0,5	—	mA
Minimum voltage	V <sub>2-6</sub>	—	1,5	—	V
<b>Vertical output (pin 3)</b>					
Output current	I <sub>3</sub>	—	—	10	mA
Output impedance	R <sub>3-6</sub>	—	400	—	Ω
<b>Feedback input (pin 4)</b>					
Input voltage					
d.c. component	V <sub>4-6</sub>	—	3	—	V
a.c. component (peak-to-peak value)	V <sub>4-6(p-p)</sub>	—	1,2	—	V
Input current	I <sub>4</sub>	—	—	12	μA
Internal precorrection to sawtooth		—	6	—	%
Deviation amplitude 50/60 Hz		—	—	5	%

DEVELOPMENT DATA

**Notes**

1. Typical value taken at starting level of AGC.
2. Signal with negative going sync, maximum white level 10% of the maximum sync amplitude (see Fig. 3).

3. Signal-to-noise ratio equals  $20 \log \frac{V_o(\text{black to white})}{V_n(\text{rms})}$  at  $B = 5 \text{ MHz}$ .

4.  $V_i(\text{rms}) = 10 \text{ mV}$ ; see Fig. 2; Q-factor = 36.

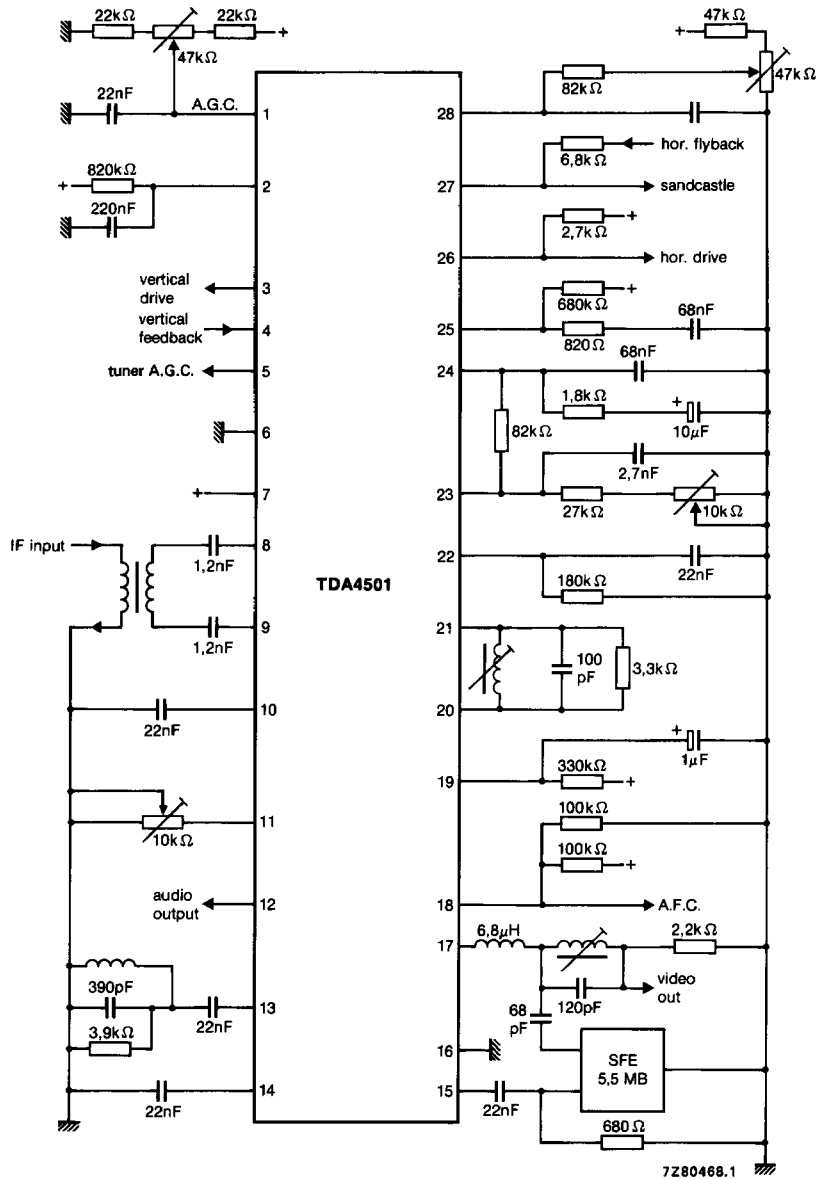

Fig. 2 Application diagram.

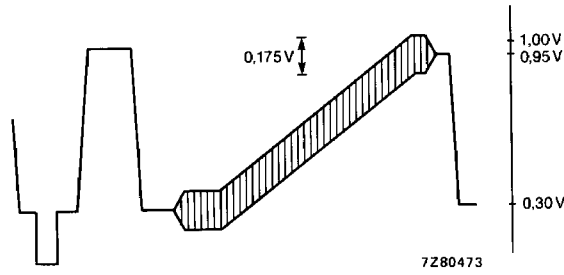

Fig. 3 Video output signal.

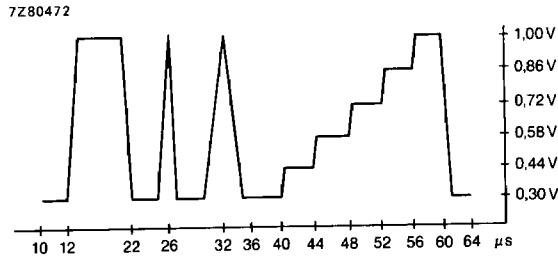

Fig. 4 E.B.U. test signal waveform (line 330).

DEVELOPMENT DATA

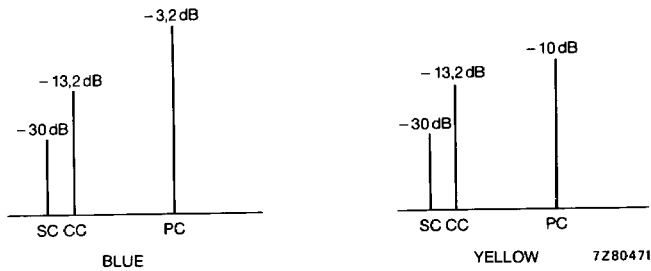

Fig. 5 Input signal conditions.

SC = sound carrier  
 CC = chrominance carrier  
 PC = picture carrier  
 all with respect to top sync level.

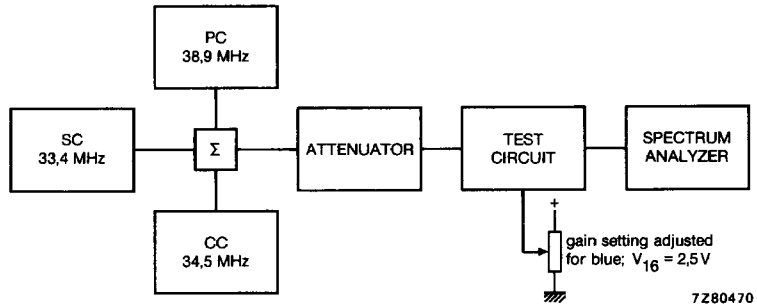

Fig. 6 Test set-up intermodulation.

$$\text{Value at 1,1 MHz: } 20 \log \frac{V_O \text{ at 4,4 MHz}}{V_O \text{ at 1,1 MHz}} + 3,6 \text{ dB}$$

$$\text{Value at 3,3 MHz: } 20 \log \frac{V_O \text{ at 4,4 MHz}}{V_O \text{ at 3,3 MHz}}$$

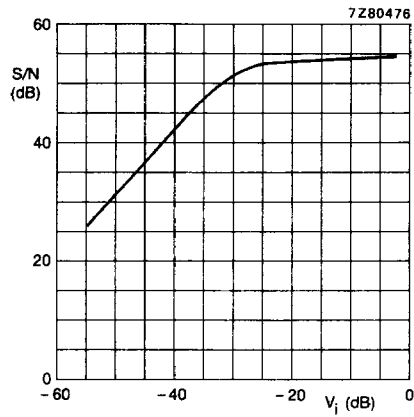

Fig. 7 S/N ratio as a function of the input voltage.

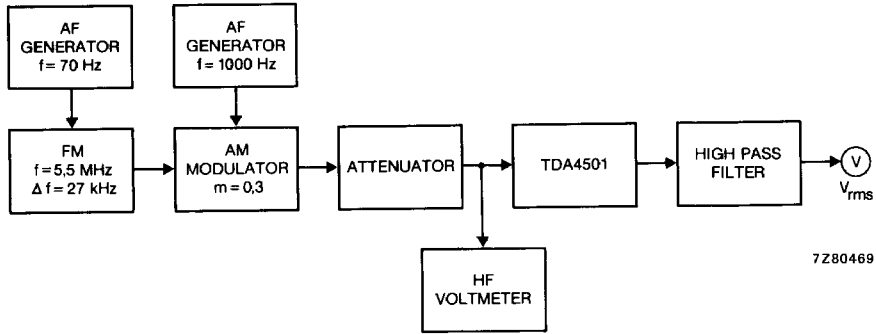

Fig. 8 Test set-up AM suppression.

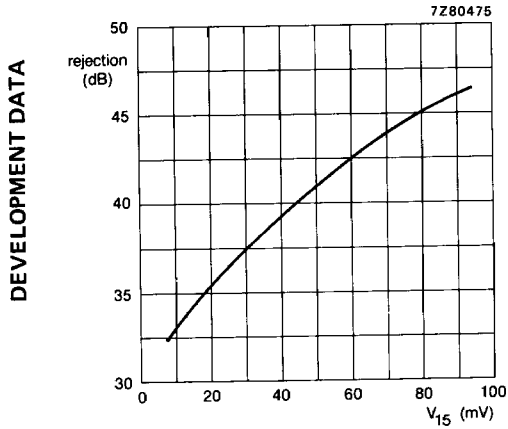

Fig. 9 AM rejection.

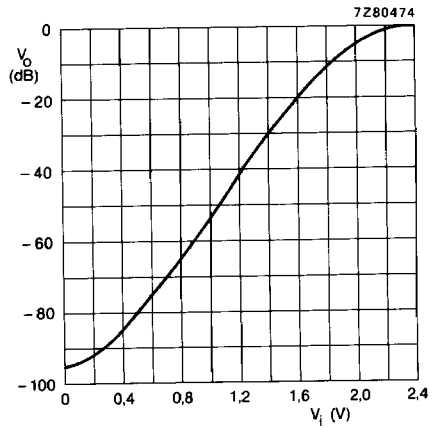

Fig. 10 Volume control characteristics.