

KA7543

Advanced Feedback Dimming Ballast Control IC

Features

- Lamp Current Feedback
- Soft Start on Feedback
- Voltage Dimming (0V~2V) on Feedback
- Switch off Control ($V_{dm}=5V$)
- Soft Dimming Control
- No Lamp Protection
- One Lamp Detection for Feedback
- Abnormal Protection
- Low Start-up and Operating Supply Current
- UVLO with 1.8V Hysteresis
- Totem Pole Output
- Trimmed 1.5% Internal Bandgap Reference
- 14-DIP & 14-SOP

Applications

- Electronic Ballast
- Lighting Control System
- Half Bridge Drive Control System

Descriptions

The KA7543 is an advanced lamp current feedback dimming control IC. This ballast control IC provides all of the necessary features to implement wide range dimming control, soft start and constant power consumption for intelligent electronic ballast systems. The KA7543 is optimized for advanced electronic ballast systems requiring minimum board area. External component counts can be reduced by adopting the KA7543. Current feedback control method of the inverter status is one of the most attractive merits in KA7543. Internal soft start circuitry eliminates the need for external soft start discrete components. Voltage controlled soft dimming circuit is built into the IC to control the lighting output in a wide range. Protection circuitry, no lamp protection, abnormal protection, one lamp detection, UVLO, restart on lamp adding, have been added.

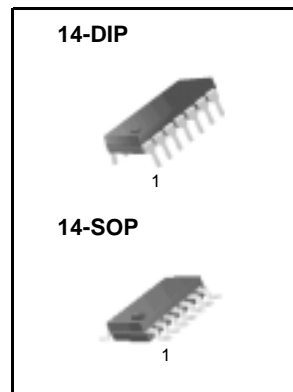

Pin Assignments

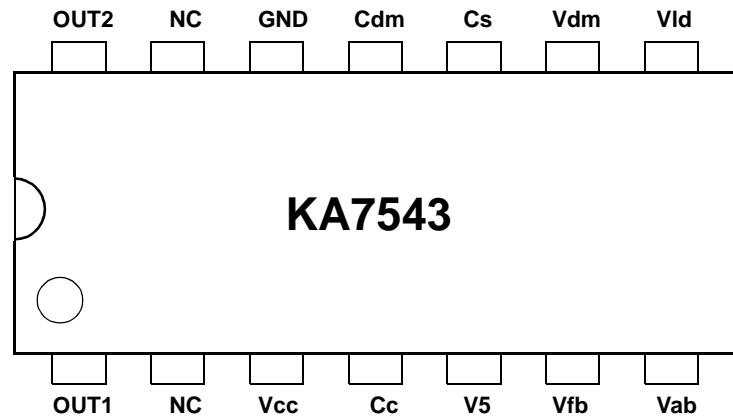

Pin Definitions

Pin Number	Pin Name	Pin Function Description
1	OUT1	Drive Output 1
2	NC	No Connection
3	Vcc	Supply Voltage Input
4	Cc	Compensation Input
5	V5	5V Voltage Source
6	Vfb	Negative Feedback Input
7	Vab	Abnormal Protection Input
8	Vld	Lamp Detection Input
9	Vdm	Dimming Control Input
10	Cs	Soft Start Time Control Input
11	Cdm	Soft Dimming Control Input
12	GND	Ground
13	NC	No Connection
14	OUT2	Drive Output 2

Absolute Maximum Ratings

Parameter	Symbol	Value	Unit
Supply Voltage	V _{CC}	30	V
Peak Drive Output Current	I _{OH} , I _{OL}	±300	mA
Drive Output Clamping Diodes V _O > V _{CC} , or V _O < -0.3	I _{clamp}	±10	mA
Operating Temperature Range	T _{opr}	-25 to 125	°C
Storage Temperature Range	T _{stg}	-65 to 150	°C
Power Dissipation	P _d	1	W
Thermal Resistance (Junction-to-Air)	θ _{ja}	123	°C/W

Absolute Maximum Ratings (-25°C ≤ T_a ≤ 125°C)

Parameter	Symbol	Value	Unit
Temperature Stability For Reference Voltage (V _{ref})	ΔV _{ref} (Typ)	20	mV
Temperature Stability For Operating Frequency (fs)	Δfs(Typ)	8	kHz

Electrical Characteristics

Unless otherwise specified, V_{CC}=12V, T_a=25°C.

Parameter	Symbol	Conditions	Min.	Typ.	Max.	Unit
UNDER VOLTAGE LOCK OUT SECTION						
Start Threshold Voltage	V _{TH} (st)	V _{CC} increasing	8.7	9.5	10.3	V
UVLO Hysteresis	HY(st)	-	1.5	1.8	2.1	V
5V Reference Voltage(Note1)	V5	I _S = 0mA	4.9	5	5.1	V
SUPPLY CURRENT SECTION						
Start Up Supply Current	I _{ST}	V _{CC} =8.5V	-	0.2	0.27	mA
Operating Supply Current	I _{CC}	Output not switching	-	7	9	mA
Dynamic Operating Supply Current (Note1)	I _{DCC}	f _o = 50kHz, C _I =1nF	-	8	12	mA
CURRENT AMPLIFIER SECTION (NOTE1)						
Output Sink Current	I _{ea} (i)	V _{fb} = 2V	12	15	18	μA
Output Source Current	I _{ea} (o)	V _{fb} = 0V	12	15	18	μA

Electrical Characteristics (Continue)

Unless otherwise specified, $V_{CC}=12V$, $T_a=25^{\circ}C$.

Parameter	Symbol	Conditions	Min.	Typ.	Max.	Unit
1 Lamp Feedback Voltage	Vfb1	Vld = 2V	0.425	0.5	0.575	V
2 Lamp Feedback Voltage	Vfb2	Vld = 4V	0.85	1	1.15	V
Output Voltage High	Vea(h)	Vfb = 0V	5.5	5.7	5.9	V
Output Voltage Low	Vea(l)	Vfb = 2V	-	-	0.4	V
OSCILLATOR SECTION(NOTE1)						
Reference Frequency	fref	$V_C = 3.0V$	37	45	53	kHz
Reference Dead Time	td	$V_C = 3.0V$	1.2	1.4	1.6	μs
Soft Start Frequency	fss	$V_C = 0V$	77	-	-	kHz
Soft Start Time Current	Iss	$V_C = 0V$	9.2	11	12.8	μA
VOLTAGE INPUT DIMMING SECTION(NOTE1)						
Dimming Voltage Range	ΔV_{dm}	-	0	-	2	V
Dimming Start Voltage	Vdm	Vdm = 0V	3.85	4	4.15	V
Initial Dimming Output Voltage	Vdm	Vdm = 0V	-0.1	0	0.1	V
OUTPUT 1/2 SECTION						
Rising Time (Note2)	tr	$V_{CC} = 12V, C_I = 1nF$	-	200	280	ns
Falling Time(Note2)	tf	$V_{CC} = 12V, C_I = 1nF$	-	50	90	ns
Output Voltage With UVLO Activated	Vomin(o)	$V_{CC} = 5V, I_O = 100\mu A$	-	-	0.9	V
PROTECTION SECTION						
Lamp Detection Voltage	Vld	-	2.5	3	3.5	V
Abnormal Detection Voltage	Vab	-	1.6	2	2.4	V
Switch Off Detection Voltage	Vso	-	4.7	5	5.3	V
No Lamp Detect Voltage	Vnd	-	0.85	1	1.15	V
PROTECTION RESET SECTION						
Protection Reset Voltage	Vpr	-	-	0.7	-	V

Notes :

1. This parameter should be tested in $V_{CC} = 11V, 14V, 30V$.
2. This parameter, although guaranteed, is not tested in production.

Operating Description

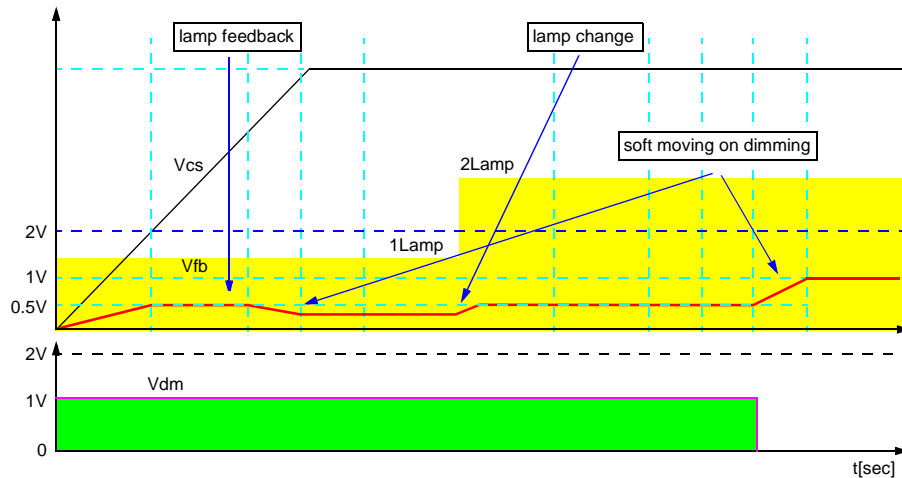

Figure 1. Operation Characteristics

The KA7543 is an advanced, lamp current feedback ballast dimming control IC which drives half bridge converter. This control IC provides all the necessary features to implement wide range dimming control, soft-start and constant power consumption for the intelligent electronic ballast system. The number of external components can be minimized by adopting the KA7543. Protection circuitry, no lamp protection, abnormal protection, one lamp detection, UVLO and restart on lamp adding have been included in the KA7543. Fig. 1 shows the operational characteristic of the KA7543 according to time and lamp count variation. When the V_{cc} voltage reaches the start-up threshold voltage(9.5V), the soft start capacitor begins to be charged. When the C_s pin voltage, V_{cs} is over 2V, the soft start operation ends. During the soft start operation, the reference voltage which controls the lamp current is proportional to V_{cs} . Dimming operation starts when V_{cs} becomes 4V and the change rate of dimming is determined by the capacitor connected to the C_{dm} pin. The more smooth dimming can be accomplished by the larger capacitor connected to the C_{dm} pin.

UVLO(Under Voltage Lock Out)

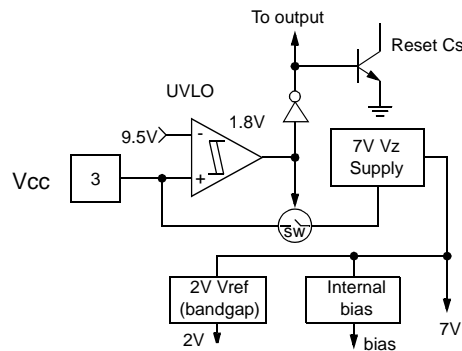

Figure 2. UVLO

Until the V_{cc} voltage reaches the start-up threshold voltage(9.5V), UVLO circuit lowers the IC operating current below $270\mu A$. When the V_{cc} voltage reaches the start-up threshold voltage, it generates IC reference voltage(V_{ref}) and supplies bias current for the whole circuitry. The hysteresis of UVLO circuit is 1.8V.

Soft Start

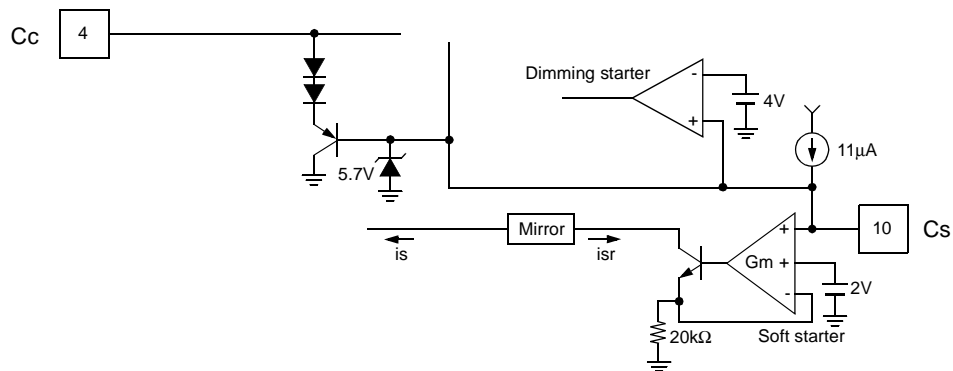

Figure 3. Soft Start

The soft start circuit charges the soft start capacitor, C_s connected to C_s pin. So the C_s pin voltage increases linearly when start-up and the current (i_s) makes the reference voltage (V_r) which is proportional to i_s current. The i_s current is maximum when the C_s pin voltage is 2V. The highest soft start frequency is determined by the C_c pin voltage ($V_{be} + 2V_d$). The operating frequency linearly decreases until the C_s pin voltage reaches 2V. During the soft start operation, the reference voltage which controls the lamp current is proportional to V_{cs} . If the C_s pin voltage is higher than 2V, the operating frequency is controlled by the feedback reference voltage. The UN-UVLO signal discharges capacitor C_s when the V_{cc} voltage is lower than UV.

Oscillator

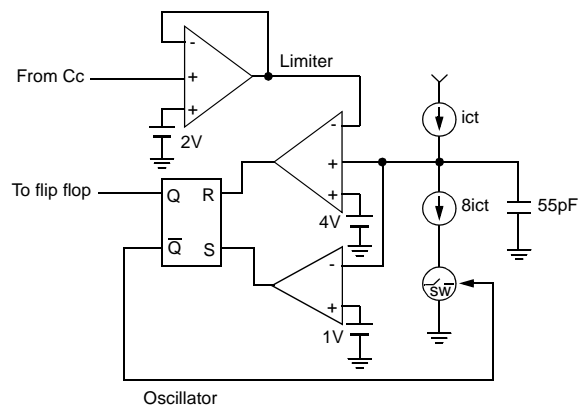

Figure 4. Oscillator

The oscillator block consists of two comparators and the ratio of charging time and discharging time is 7:1. The current source, i_{ct} charges 55pF capacitor until the capacitor voltage meets the upper limit voltage. After that time, $7 \cdot i_{ct}$ current discharges the capacitor until it meet the lower limit voltage, 1V. The upper limit voltage is between 2V and 4V. The operating frequency is highest when the upper limit voltage is 2V and it is lowest when the upper limit voltage is 4V. The lowest operating frequency guarantees the zero voltage switching operation of the ballast system.

Dimming Control Stage

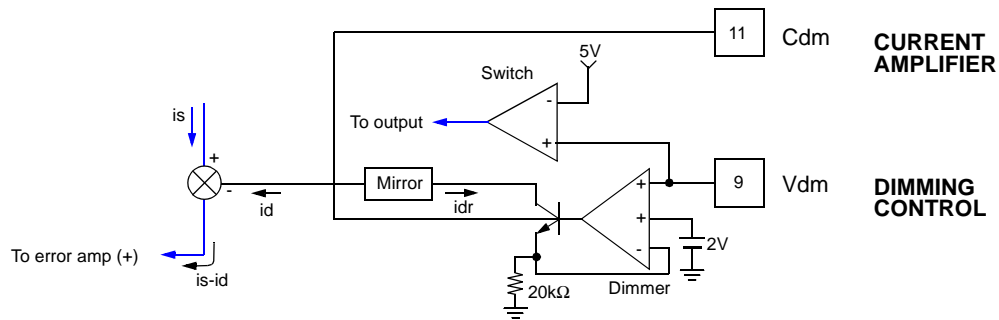

Figure 5. Dimming Control Stage

The condition for full dimming is when the V_{dm} voltage is 2V and the condition for full lighting is when the V_{dm} voltage is 0V. Dimming operation starts when V_{cs} becomes 4V and the change rate of dimming is determined by the capacitor connected to the Cdm pin. The more smooth dimming can be accomplished by the larger capacitor connected to the Cdm pin. If the V_{dm} pin voltage is higher than 5V, then the output drive stage remains in off state. Dimming control and output drive on/off control can be achieved with only one pin.

Output Drive Stage

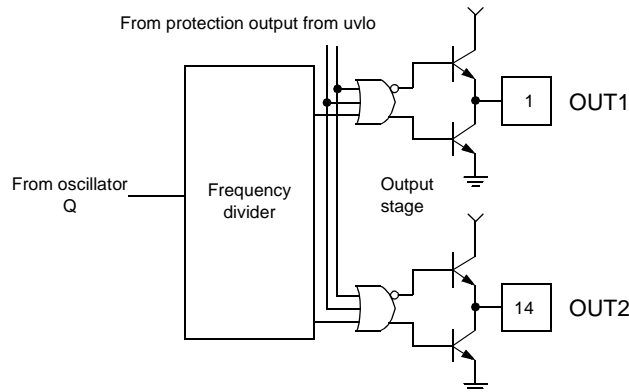

Figure 6. Output Drive Stage

OUT1 and OUT2 are complementary and there is 1.4 μ s dead time for the ZVS operation. The structure of output stage is the totem-pole output stage. For the high side MOSFET drive, a pulse transformer is necessary.

No Lamp Protection

If the V_{ld} pin voltage is lower than 1V, it means that there is no lamp connected. On no lamp condition, the output drive stage is in off state.

Components List (32W*2Lamp Application)

Part Number	Value	Note	Manufacturer
R1	1.8M Ω	1/4W	-
R2	25k Ω	1/4W	-
R3, 21	150k Ω	1W	-
R4, 11	22k Ω	1/4W	-
R5	10 Ω	1/4W	-
R6	0.68 Ω	1W	-
R7	1.0M Ω	1/4W	-
R8	6k Ω	1/4W	-
R9	103	Variable resistor	-
R10	6.8 Ω	1W	-
R12, 13	47 Ω	1W	-
R14	180k Ω	1/4W	-
R15, 16	330k Ω	1/4W	-
R17, 18	680k Ω	1/4W	-
R19	8.2k Ω	1/4W	-
C1, 2	150nF, 275Vac	Box-Cap	-
C3, 4	2200pF, 3000V	Y-Cap	-
C5	0.33 μ F, 630V	Miller-Cap	-
C6, 24	47 μ F, 35V	Electrolytic	-
C7	1 μ F	MLCC	-
C8, 11	1nF, 25V	Ceramic	-
C9	47 μ F, 450V	Electrolytic	-
C10	0.22 μ F, 25V	Ceramic	-
C12, 21	0.1 μ F, 25V	Ceramic	-
C13	10nF, 25V	Ceramic	-
C14	1nF, 630V	Miller-Cap	-
C15,16	4700pF, 1000V	Miller-Cap	-
C17, 18, 19, 20	6800pF, 630V	Miller-Cap	-
C22, 23	22 μ F, 35V	Electrolytic	-
Q1, 2, 3	500V, 4.5A	IRFS830B	Fairchild
D1, 2, 3, 4	1000V, 1A	1N4007	-
D5	600V, 1A	BYV26C	-
D6, 7	600V, 1A	1N4937	-
D8	75V, 150mA	1N4148	-
ZD1	15V, 1W	1N4744	-
L1	45mH	Line Filter	-
L2, 3	3.1mH(120T)	EI2820	-
T1	0.9mH(80T:6T)	EI2820	-
T2	1.2mH(30T:60T)	EE1614	-
F1	250V, 3A	Fuse	-
TNR	470V	471	-
NTC	10 Ω	10D09	-

Components List(36W*2Lamp Application) (Continued)

Part Number	Value	Note	Manufacturer
R1	1.8M Ω	1/4W	-
R2	22k Ω	1/4W	-
R3, 21	150k Ω	1W	-
R4, 11	22k Ω	1/4W	-
R5	10 Ω	1/4W	-
R6	0.68 Ω	1W	-
R7	1M Ω	1/4W	-
R8	6k Ω	1/4W	-
R9	103	Variable resistor	-
R10	6.8 Ω	1W	-
R12, 13	47 Ω	1W	-
R14	180k Ω	1/4W	-
R15, 16	330k Ω	1/4W	-
R17, 18	680k Ω	1/4W	-
R19	8.2k Ω	1/4W	-
C1, 2	150nF, 275Vac	Box-Cap	-
C3, 4	2200pF, 3000V	Y-Cap	-
C5	0.33 μ F, 630V	Miller-Cap	-
C6, 24	47 μ F, 35V	Electrolytic	-
C7	1 μ F	MLCC	-
C8, 11	1nF, 25V	Ceramic	-
C9	47 μ F, 450V	Electrolytic	-
C10	0.22 μ F, 25V	Ceramic	-
C12, 21	0.1 μ F, 25V	Ceramic	-
C13	10nF, 25V	Ceramic	-
C14	1nF, 630V	Miller-Cap	-
C15,16	3300pF, 1000V	Miller-Cap	-
C17, 18, 19, 20	6800pF, 630V	Miller-Cap	-
C22, 23	22 μ F, 35V	Electrolytic	-
Q1, 2, 3	500V, 4.5A	IRFS830B	Fairchild
D1, 2, 3, 4	1000V, 1A	1N4007	-
D5	600V, 1A	BYV26C	-
D6, 7	600V, 1A	1N4937	-
D8	75V, 150mA	1N4148	-
ZD1	15V, 1W	1N4744	-
L1	45mH	Line Filter	-
L2, 3	3.1mH(120T)	EI2820	-
T1	0.9mH(80T:6T)	EI2820	-
T2	1.2mH(30T:60T)	EE1614	-
F1	250V, 3A	Fuse	-
TNR	470V	471	-
NTC	10 Ω	10D09	-

Mechanical Dimensions

Package

Dimensions in millimeters

14-DIP

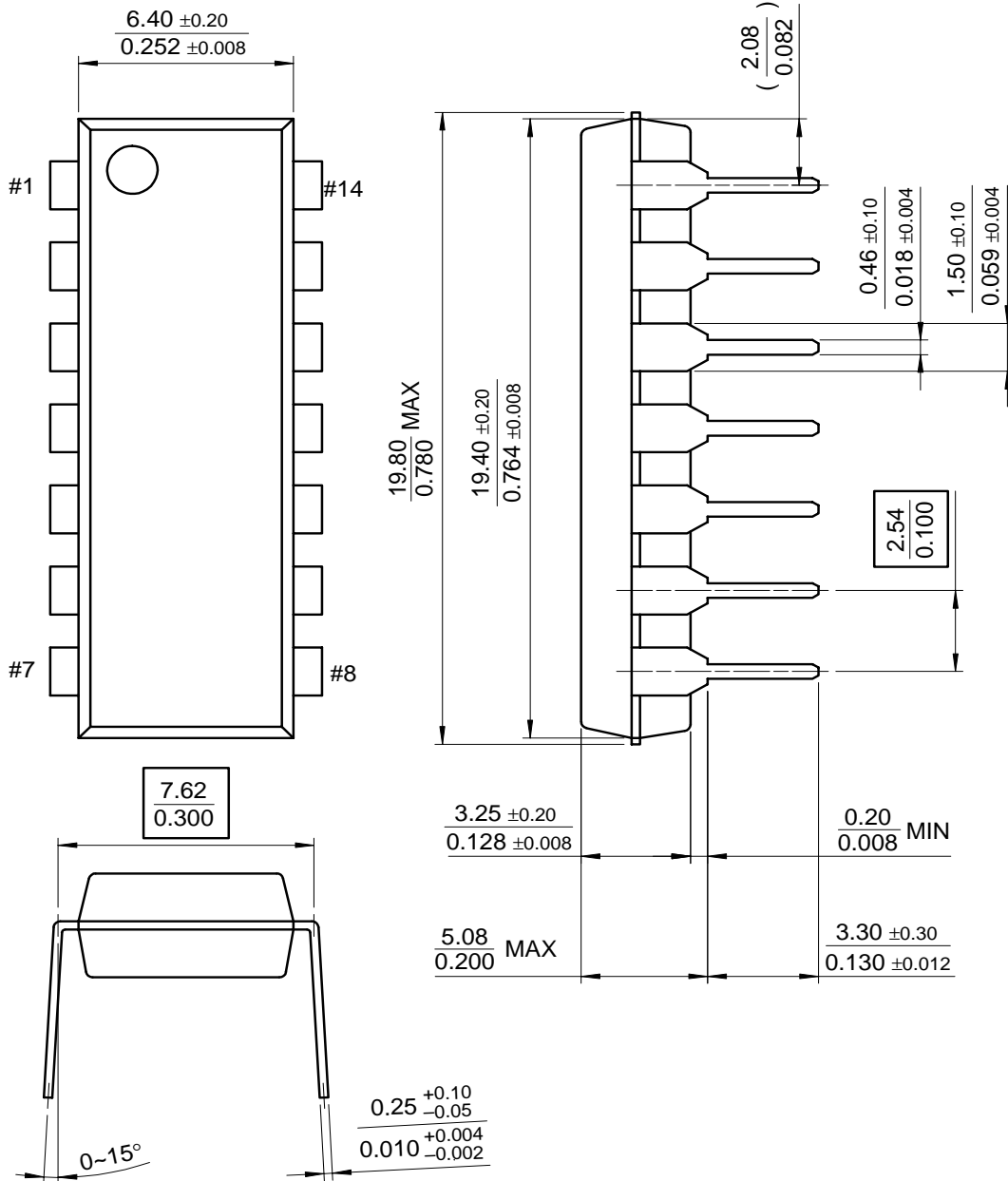

Mechanical Dimensions (Continued)

Package

Dimensions in millimeters

14-SOP

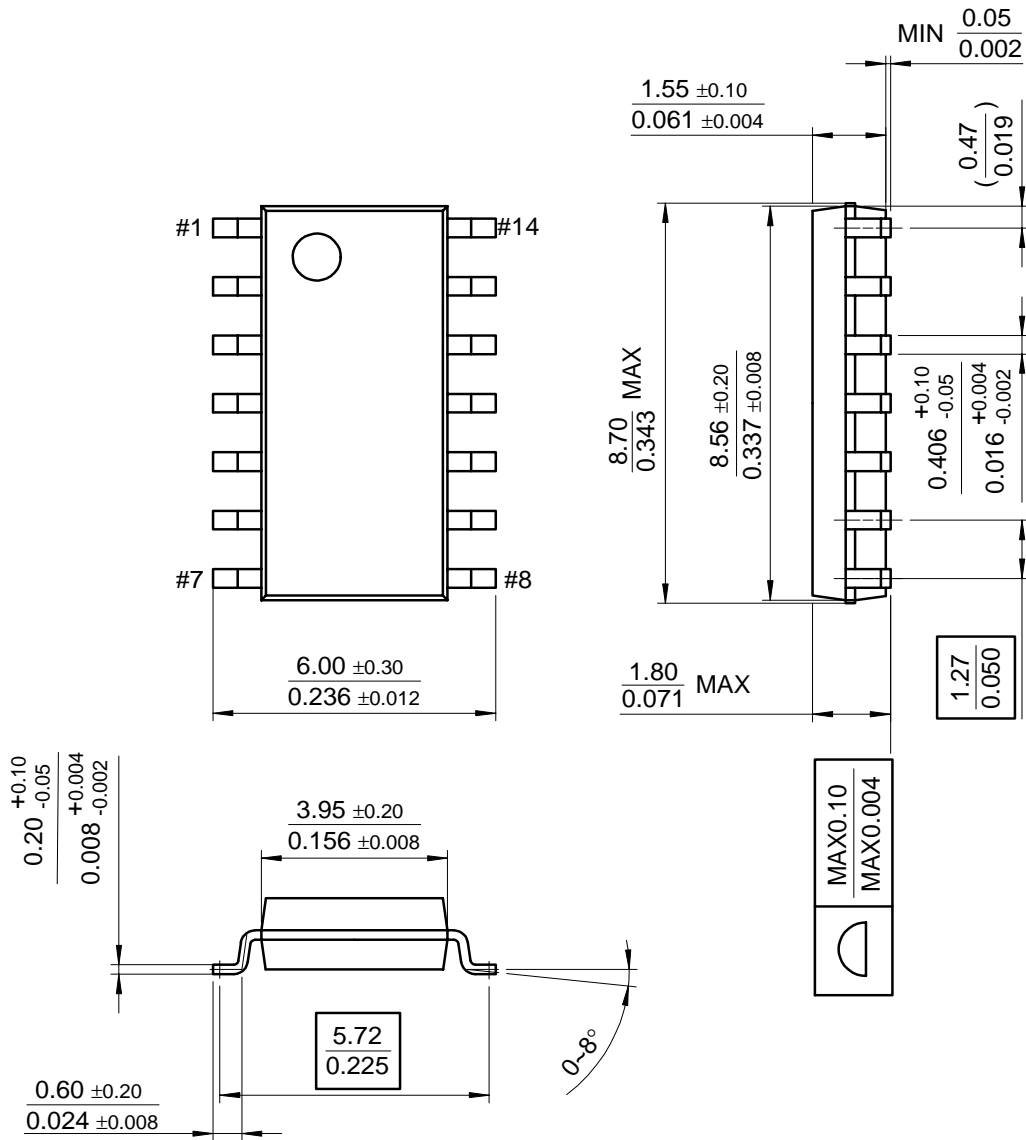

Ordering Information

Product Number	Package	Operating Temperature
KA7543	14-DIP	-25°C ~ +125°C
KA7543D	14-SOP	

DISCLAIMER

FAIRCHILD SEMICONDUCTOR RESERVES THE RIGHT TO MAKE CHANGES WITHOUT FURTHER NOTICE TO ANY PRODUCTS HEREIN TO IMPROVE RELIABILITY, FUNCTION OR DESIGN. FAIRCHILD DOES NOT ASSUME ANY LIABILITY ARISING OUT OF THE APPLICATION OR USE OF ANY PRODUCT OR CIRCUIT DESCRIBED HEREIN; NEITHER DOES IT CONVEY ANY LICENSE UNDER ITS PATENT RIGHTS, NOR THE RIGHTS OF OTHERS.

LIFE SUPPORT POLICY

FAIRCHILD'S PRODUCTS ARE NOT AUTHORIZED FOR USE AS CRITICAL COMPONENTS IN LIFE SUPPORT DEVICES OR SYSTEMS WITHOUT THE EXPRESS WRITTEN APPROVAL OF THE PRESIDENT OF FAIRCHILD SEMICONDUCTOR CORPORATION. As used herein:

1. Life support devices or systems are devices or systems which, (a) are intended for surgical implant into the body, or (b) support or sustain life, and (c) whose failure to perform when properly used in accordance with instructions for use provided in the labeling, can be reasonably expected to result in a significant injury of the user.
2. A critical component in any component of a life support device or system whose failure to perform can be reasonably expected to cause the failure of the life support device or system, or to affect its safety or effectiveness.