

TOSHIBA FIELD EFFECT TRANSISTOR SILICON N CHANNEL JUNCTION TYPE

2SK192A

FM TUNER APPLICATIONS

VHF BAND AMPLIFIER APPLICATIONS

- High Power Gain : $G_{PS} = 24\text{dB (Typ.) (}f = 100\text{MHz)}$
- Low Noise Figure : $NF = 1.8\text{dB (Typ.) (}f = 100\text{MHz)}$
- High Forward Transfer Admittance
: $|y_{fs}| = 7\text{mS (Typ.) (}f = 1\text{kHz)}$

MAXIMUM RATINGS ($T_a = 25^\circ\text{C}$)

CHARACTERISTIC	SYMBOL	RATING	UNIT
Gate-Drain Voltage	V_{GDO}	-18	V
Gate Current	I_G	10	mA
Drain Power Dissipation	P_D	200	mW
Junction Temperature	T_j	125	$^\circ\text{C}$
Storage Temperature Range	T_{stg}	-55~125	$^\circ\text{C}$

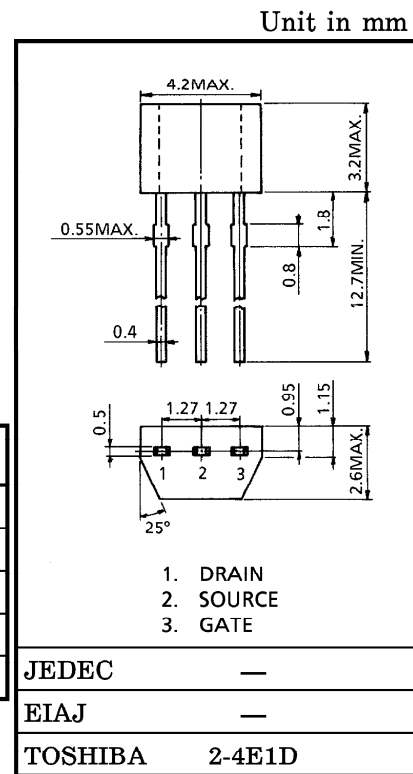

Weight : 0.13g

ELECTRICAL CHARACTERISTICS ($T_a = 25^\circ\text{C}$)

CHARACTERISTIC	SYMBOL	TEST CONDITION	MIN.	TYP.	MAX.	UNIT
Gate Leakage Current	I_{GSS}	$V_{GS} = -1.0\text{V}, V_{DS} = 0$	—	—	-10	nA
Gate-Drain Breakdown Voltage	$V_{(BR)GDO}$	$I_G = -100\mu\text{A}$	-18	—	—	V
Drain Current	I_{DSS} (Note)	$V_{GS} = 0, V_{DS} = 10\text{V}$	3	—	24	mA
Gate-Source Cut-off Voltage	$V_{GS(OFF)}$	$V_{DS} = 10\text{V}, I_D = 1\mu\text{A}$	-1.2	-3	—	V
Forward Transfer Admittance	$ y_{fs} $	$V_{GS} = 0, V_{DS} = 10\text{V}, f = 1\text{kHz}$	—	7	—	mS
Input Capacitance	C_{iss}	$V_{DS} = 10\text{V}, V_{GS} = 0, f = 1\text{MHz}$	—	3.5	—	pF
Reverse Transfer Capacitance	C_{rss}	$V_{DS} = -10\text{V}, f = 1\text{MHz}$	—	—	0.65	pF
Power Gain	G_{PS}	$V_{DD} = 10\text{V}, f = 100\text{MHz (Fig.1)}$	—	24	—	dB
Noise Figure	NF	$V_{DD} = 10\text{V}, f = 100\text{MHz (Fig.1)}$	—	1.8	3.5	dB

Note : I_{DSS} Classification Y : 3.0~7.0, GR : 6.0~14.0, BL : 12.0~24.0

961001EAA2

- TOSHIBA is continually working to improve the quality and the reliability of its products. Nevertheless, semiconductor devices in general can malfunction or fail due to their inherent electrical sensitivity and vulnerability to physical stress. It is the responsibility of the buyer, when utilizing TOSHIBA products, to observe standards of safety, and to avoid situations in which a malfunction or failure of a TOSHIBA product could cause loss of human life, bodily injury or damage to property. In developing your designs, please ensure that TOSHIBA products are used within specified operating ranges as set forth in the most recent products specifications. Also, please keep in mind the precautions and conditions set forth in the TOSHIBA Semiconductor Reliability Handbook.
- The information contained herein is presented only as a guide for the applications of our products. No responsibility is assumed by TOSHIBA CORPORATION for any infringements of intellectual property or other rights of the third parties which may result from its use. No license is granted by implication or otherwise under any intellectual property or other rights of TOSHIBA CORPORATION or others.
- The information contained herein is subject to change without notice.

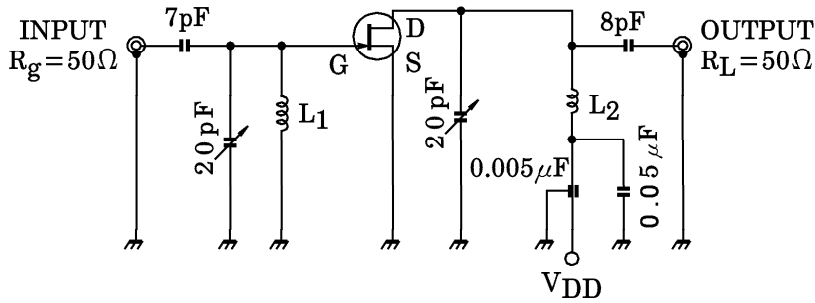

L₁ : 0.8mmϕ Ag PLATED Cu WIRE 3 TURNS, 10mm I_D, 10mm LENGTH
 L₂ : 0.8mmϕ Ag PLATED Cu WIRE 3.5 TURNS, 10mm I_D, 10mm LENGTH

Fig.1 100MHz Gps, NF TEST CIRCUIT

STATIC CHARACTERISTICS

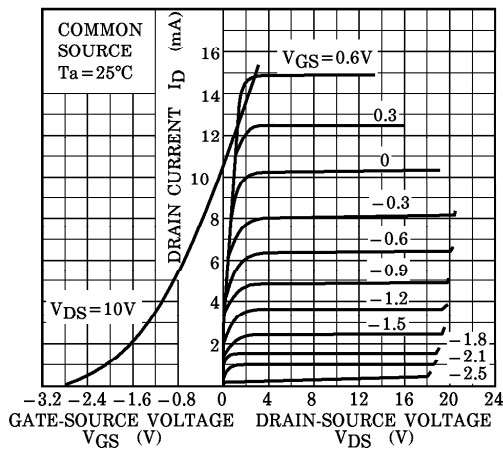

I_D - V_{GS}

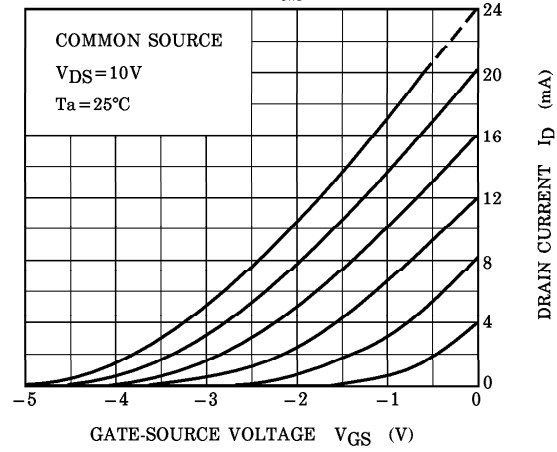

I_D - V_{DS} (LOW VOLTAGE REGION)

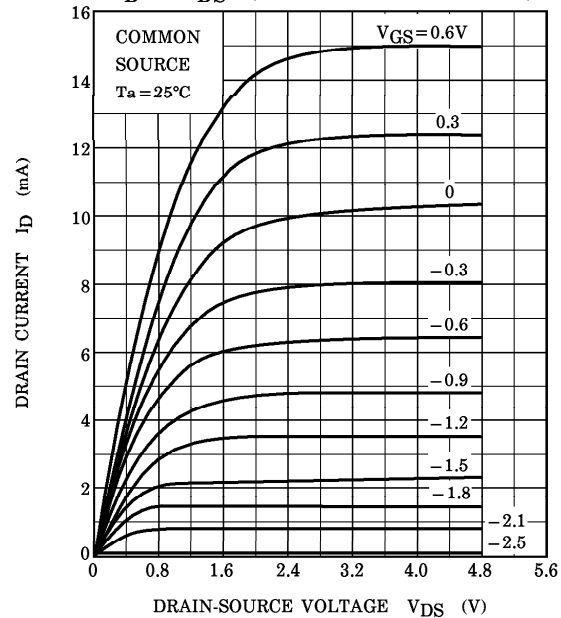

|Y_{fs}| - I_D

