

HYB18T256400AF  
HYB18T256800AF  
HYB18T256160AF

256 Mbit DDR2 SDRAM

Memory Products



N e v e r   s t o p   t h i n k i n g .

**Edition 2004-04-02**

**Published by Infineon Technologies AG,  
St.-Martin-Strasse 53,  
81669 München, Germany**

**© Infineon Technologies AG 5/7/04.  
All Rights Reserved.**

**Attention please!**

The information herein is given to describe certain components and shall not be considered as a guarantee of characteristics.

Terms of delivery and rights to technical change reserved.

We hereby disclaim any and all warranties, including but not limited to warranties of non-infringement, regarding circuits, descriptions and charts stated herein.

Infineon Technologies is an approved CECC manufacturer.

**Information**

For further information on technology, delivery terms and conditions and prices please contact your nearest Infineon Technologies Office in Germany or our Infineon Technologies Representatives worldwide ([www.infineon.com](http://www.infineon.com)).

**Warnings**

Due to technical requirements components may contain dangerous substances. For information on the types in question please contact your nearest Infineon Technologies Office.

Infineon Technologies Components may only be used in life-support devices or systems with the express written approval of Infineon Technologies, if a failure of such components can reasonably be expected to cause the failure of that life-support device or system, or to affect the safety or effectiveness of that device or system. Life support devices or systems are intended to be implanted in the human body, or to support and/or maintain and sustain and/or protect human life. If they fail, it is reasonable to assume that the health of the user or other persons may be endangered.

## DATASHEET Rev. 1.02 (05.04)

### Features

- High Performance:

Speed Sorts	-5 DDR2 -400	-3.7 DDR2 -533	-3S DDR2 -667	-3 DDR2 -667	Units
Bin (CL-tRCD-TRP)	3-3-3	4-4-4	5-5-5	4-4-4	tck
max. Clock Frequency	200	266	333		MHz
Data Rate	400	533	667		Mb/s/pin
$\overline{\text{CAS}}$ Latency (CL)	3	4	5	4	tck
tRCD	15	15	15	12	ns
tRP	15	15	15	12	ns
tRAS	40	45	45	45	ns
tRC	55	60	60	57	ns

- 1.8V ± 0.1V Power Supply  
1.8 V ± 0.1V (SSTL\_18) compatible) I/O
- DRAM organisations with 4, 8 and 16 data in/outputs
- Double Data Rate architecture: two data transfers per clock cycle, four internal banks for concurrent operation
- $\overline{\text{CAS}}$  Latency: 3, 4 and 5
- Burst Length: 4 and 8

- Differential clock inputs (CK and  $\overline{\text{CK}}$ )
- Bi-directional, differential data strobes (DQS and  $\overline{\text{DQS}}$ ) are transmitted / received with data. Edge aligned with read data and center-aligned with write data
- DLL aligns DQ and DQS transitions with clock
- $\overline{\text{DQS}}$  can be disabled for single-ended data strobe operation
- Commands entered on each positive clock edge, data and data mask are referenced to both edges of DQS
- Data masks (DM) for write data
- Posted  $\overline{\text{CAS}}$  by programmable additive latency for better command and data bus efficiency
- Off-Chip-Driver impedance adjustment (OCD) and On-Die-Termination (ODT) for better signal quality.
- Auto-Precharge operation for read and write bursts
- Auto-Refresh, Self-Refresh and power saving Power-Down modes
- Average Refresh Period 7.8µs at a T<sub>CASE</sub> lower than 85°C, 3.9µs between 85°C and 95°C
- Normal and Weak Strength Data-Output Drivers
- 1k page size
- Lead-free Packages:
  - 60 pin FBGA for x4 & x8 components
  - 84 pin FBPA for x16 components

### 1.0 Description

The 256Mb Double-Data-Rate-2 (DDR2) DRAMs are high-speed CMOS Double Data Rate 2 Synchronous DRAM devices containing 268,435,456 bits and are internally configured as a quad-bank DRAMs. The 256Mb chip is organized as either 16Mbit x 4 I/O x 4 bank, 8Mbit x 8 I/O x 4 bank or 4Mbit x 16 I/O x 4 bank device. These synchronous devices achieve high speed double-data-rate transfer rates of up to 667 Mb/sec/pin for general applications.

The chip is designed to comply with all key DDR2 DRAM key features: (1) posted  $\overline{\text{CAS}}$  with additive latency, (2) write latency = read latency -1, (3) normal and weak strength data-output driver, (4) Off-Chip Driver (OCD) impedance adjustment and (5) an ODT (On-Die Termination) function.

All of the control and address inputs are synchronized with a pair of externally supplied differential clocks. Inputs are latched at the cross point of differential clocks (CK rising and  $\overline{\text{CK}}$  falling). All I/Os are synchronized with a single ended DQS or differential (DQS,  $\overline{\text{DQS}}$ ) pair in a source synchronous fashion. A 15 bit address bus is used to convey row, column and bank address information in a  $\overline{\text{RAS}}$  /  $\overline{\text{CAS}}$  multiplexing style.

The DDR2 devices operate with a 1.8V +/-0.1V power supply and are available in FBGA packages.

An Auto-Refresh and Self-Refresh mode is provided along with various power-saving power-down modes.

The functionality described and the timing specifications included in this data sheet are for the DLL Enabled mode of operation.

## 1.1 Ordering Information

Part Number	CAS Latency	Clock (MHz)	Speed Sort	DRAM Organisation	Package
HYB18T256400AF(L)-5	3, 4 & 5	200	DDR2-400	4 banks x 16 Mbits x 4	60 pin FBGA
HYB18T256800AF(L)-5				4 banks x 8 Mbits x 8	60 pin FBGA
HYB18T256160AF(L)-5				4 banks x 4 Mbits x 16	84 pin FBGA
HYB18T256400AF(L)-3.7	4 & 5	266	DDR2-533	4 banks x 16 Mbits x 4	60 pin FBGA
HYB18T256800AF(L)-3.7				4 banks x 8 Mbits x 8	60 pin FBGA
HYB18T256160AF(L)-3.7				4 banks x 4 Mbits x 16	84 pin FBGA
HYB18T256400AF(L)-3	4 & 5	333	DDR2-667	4 banks x 16 Mbits x 4	60 pin FBGA
HYB18T256800AF(L)-3				4 banks x 8 Mbits x 8	60 pin FBGA
HYB18T256160AF(L)-3				4 banks x 4 Mbits x 16	84 pin FBGA
HYB18T256400AF(L)-3S	5			4 banks x 16 Mbits x 4	60 pin FBGA
HYB18T256800AF(L)-3S				4 banks x 8 Mbits x 8	60 pin FBGA
HYB18T256160A(L)-3S				4 banks x 4 Mbits x 16	84 pin FBGA

Notes:

- 1) For product nomenclature see section 10 of this datasheet
- 2) Versions with an "L" in the part numbers are Low Power versions of the standard component with reduced IDD6 Self-Refresh current. See section 6.1 for IDD current specifications.
- 3) All FBGA packages are lead-free.

## 1.2 Pin Description

### 1.2.1 x4 Components

Symbol	Function	Symbol	Function
A0~A12	Row Address Inputs	DQS, $\overline{DQS}$	Differential Data Strobes
A0~A9,A11	Column Address Inputs	NC	No Connection (Chip to Pin)
BA0, BA1	Bank Address Inputs	VDD	Supply Voltage
A10/AP	Column Address Input for Auto-Precharge	VSS	Ground
$\overline{CS}$	Chip Select	VDDQ	Supply Voltage for DQ
$\overline{RAS}$	Row Address Strobe	VSSQ	Ground for DQs
$\overline{CAS}$	Column Address Strobe	VDDL	Supply Voltage for DLL
$\overline{WE}$	Write Enable	VSSDL	Ground for DLL
DQ0~DQ3	Data Inputs/Outputs (x4)	VREF	Reference Voltage for SSTL Inputs
CKE	Clock Enable	ODT	On Die Termination Enable
CK, $\overline{CK}$	Differential Clock Inputs	RFU	Reserved for future use
DM	Data Input Mask	NC	Not Connected

### 1.2.1 x8 Components

Symbol	Function	Symbol	Function
A0~A12	Row Address Inputs	DQS, $\overline{\text{DQS}}$	Differential Data Strokes
A0~A9	Column Address Inputs	RDQS, $\overline{\text{RDQS}}$	Differential Read Data Strokes
BA0, BA1	Bank Address Inputs	VDD	Supply Voltage
A10/AP	Column Address Input for Auto-Precharge	VSS	Ground
$\overline{\text{CS}}$	Chip Select	VDDQ	Supply Voltage for DQ
$\overline{\text{RAS}}$	Row Address Strobe	VSSQ	Ground for DQs
$\overline{\text{CAS}}$	Column Address Strobe	VDDL	Supply Voltage for DLL
$\overline{\text{WE}}$	Write Enable	VSSDL	Ground for DLL
DQ0~DQ7	Data Inputs/Outputs (x8)	VREF	Reference Voltage for SSTL Inputs
CKE	Clock Enable	ODT	On Die Termination Enable
CK, $\overline{\text{CK}}$	Differential Clock Inputs	RFU	Reserved for future use
DM	Data Input Mask	NC	Not connected

### 1.2.3 x16 Components

Symbol	Function	Symbol	Function
A0~A12	Row Address Inputs	LDQS, $\overline{\text{LDQS}}$ UDQS, $\overline{\text{UDQS}}$	Differential Data Strokes
A0~A8	Column Address Inputs	NC	No Connection (Chip to Pin)
BA0, BA1	Bank Address Inputs	VDD	Supply Voltage
A10/AP	Column Address Input for Auto-Precharge	VSS	Ground
$\overline{\text{CS}}$	Chip Select	VDDQ	Supply Voltage for DQ
$\overline{\text{RAS}}$	Row Address Strobe	VSSQ	Ground for DQs
$\overline{\text{CAS}}$	Column Address Strobe	VDDL	Supply Voltage for DLL
$\overline{\text{WE}}$	Write Enable	VSSDL	Ground for DLL
LDQ0~7, UDQ0~7	Data Inputs/Outputs	VREF	Reference Voltage for SSTL Inputs
CKE	Clock Enable	ODT	On Die Termination Enable
CK, $\overline{\text{CK}}$	Differential Clock Inputs	RFU	reserved for future use
LDM, UDM	Data Input Masks	NC	Not connected

### 1.3 256Mbit DDR2 Addressing

Configuration	64Mb x 4	32Mb x 8	16Mb x 16
# of Banks	4	4	4
Bank Address	BA0, BA1	BA0, BA1	BA0, BA1
Auto-Precharge	A10 / AP	A10 / AP	A10 / AP
Row Address	A0 ~ A12	A0 ~ A12	A0 ~ A12
Column Address	A0 ~ A9, A11	A0 ~ A9	A0 ~ A8
Page Length	2048 bits	1024 bits	512 bits
Page Size	1024 (1kB)	1024 (1kB)	1024 (1kB)

page length =  $2^{\text{colbit}}$ ,  
page size in bytes =  $2^{\text{colbits}} \times \text{ORG} / 8$   
where colbits is the number of column address bits and ORG the number of I/O (DQ) bits.

### 1.4 Package Pinout & Addressing

#### 1.4.1 Package Pinout for x4 components, 60 pins, FBGA Package (top view)

1	2	3		7	8	9
VDD	NC	VSS	A	VSSQ	$\overline{\text{DQS}}$	VDDQ
NC	VSSQ	DM	B	DQS	VSSQ	NC
VDDQ	DQ1	VDDQ	C	VDDQ	DQ0	VDDQ
NC	VSSQ	DQ3	D	DQ2	VSSQ	NC
VDDL	VREF	VSS	E	VSSDL	CK	VDD
	CKE	$\overline{\text{WE}}$	F	$\overline{\text{RAS}}$	$\overline{\text{CK}}$	ODT
RFU	BA0	BA1	G	$\overline{\text{CAS}}$	$\overline{\text{CS}}$	
	A10	A1	H	A2	A0	VDD
VSS	A3	A5	J	A6	A4	
	A7	A9	K	A11	A8	VSS
VDD	A12	NC,(A14)	L	NC,(A15)	NC,(A13)	

Notes:

- 1) VDDL and VSSDL are power and ground for the DLL. They are isolated on the device from VDD, VDDQ, VSS and VSSQ.
- 2) NC, (A13), NC,(A14) and NC,(A15) are additional address pins for future generation DRAMs and are not connected on this component
- 3) Ball position G1 "RFU" will be used for BA2 on 1Gbit memory densities and higher

**1.4.2 Package Pinout for x8 components, 60 pins, FBGA Package (top view)**

1	2	3		7	8	9
VDD	$\overline{\text{NU}}$ , $\overline{\text{RDQS}}$	VSS	A	VSSQ	$\overline{\text{DQS}}$	VDDQ
DQ6	VSSQ	DM, $\overline{\text{RDQS}}$	B	DQS	VSSQ	DQ7
VDDQ	DQ1	VDDQ	C	VDDQ	DQ0	VDDQ
DQ4	VSSQ	DQ3	D	DQ2	VSSQ	DQ5
VDDL	VREF	VSS	E	VSSDL	CK	VDD
	CKE	$\overline{\text{WE}}$	F	$\overline{\text{RAS}}$	$\overline{\text{CK}}$	ODT
RFU	BA0	BA1	G	$\overline{\text{CAS}}$	$\overline{\text{CS}}$	
	A10	A1	H	A2	A0	VDD
VSS	A3	A5	J	A6	A4	
	A7	A9	K	A11	A8	VSS
VDD	A12	NC,(A14)	L	NC,(A15)	NC,(A13)	

Notes:

- 1) RDQS /  $\overline{\text{RDQS}}$  are enabled by EMRS(1) command.
- 2) If RDQS /  $\overline{\text{RDQS}}$  is enabled, the DM function is disabled
- 3) When enabled, RDQS &  $\overline{\text{RDQS}}$  are used as strobe signals during reads.
- 4) VDDL and VSSDL are power and ground for the DLL. They are isolated on the device from VDD, VDDQ, VSS and VSSQ.
- 5) NC,(A13), NC,(A14) and NC,(A15) are additional address pins for future generation DRAMs and are not connected on this component.
- 6) Ball position G1 "RFU" will be used for BA2 on 1Gbit memory densities and higher

**1.4.3 Package Pinout for x16 components 84 pins, FBGA Package (top view)**

1	2	3			7	8	9
VDD	NC	VSS		A	VSSQ	$\overline{\text{UDQS}}$	VDDQ
UDQ6	VSSQ	UDM		B	UDQS	VSSQ	UDQ7
VDDQ	UDQ1	VDDQ		C	VDDQ	UDQ0	VDDQ
UDQ4	VSSQ	DQ3		D	UDQ2	VSSQ	UDQ5
VDD	NC	VSS		E	VSSQ	$\overline{\text{LDQS}}$	VDDQ
LDQ6	VSSQ	LDM		F	LDQS	VSSQ	LDQ7
VDDQ	LDQ1	VDDQ		G	VDDQ	LDQ0	VDDQ
LDQ4	VSSQ	LDQ3		H	LDQ2	VSSQ	LDQ5
VDDL	VREF	VSS		J	VSSDL	CK	VDD
	CKE	$\overline{\text{WE}}$		K	$\overline{\text{RAS}}$	$\overline{\text{CK}}$	ODT
RFU	BA0	BA1		L	$\overline{\text{CAS}}$	$\overline{\text{CS}}$	
	A10	A1		M	A2	A0	VDD
VSS	A3	A5		N	A6	A4	
	A7	A9		P	A11	A8	VSS
VDD	A12	NC,(A14)		R	NC,(A15)	NC,A13)	

Notes:

- 1)  $\overline{\text{UDQS}}$ / $\overline{\text{UDQS}}$  is data strobe for upper byte,  $\overline{\text{LDQS}}$ / $\overline{\text{LDQS}}$  is data strobe for lower byte
- 2) UDM is the data mask signal for the upper byte UDQ0~UDQ7, LDM is the data mask signal for the lower byte LDQ0~LDQ7
- 3) NC,(A13), NC, (A14) and NC, (A15) are additional address pins for future generation DRAMs and are not connected on this component.
- 4) Ball position G1 "RFU" will be used for BA2 on 1Gbit memory densities and higher



## 1.5 Input/Output Functional Description

Symbol	Type	Function
CK, $\overline{\text{CK}}$	Input	<b>Clock:</b> CK and $\overline{\text{CK}}$ are differential system clock inputs. All address and control inputs are sampled on the crossing of the positive edge of CK and negative edge of $\overline{\text{CK}}$ . Output (read) data is referenced to the crossing of CK and $\overline{\text{CK}}$ (both direction of crossing)
CKE	Input	<b>Clock Enable:</b> CKE high activates and CKE low deactivates internal clock signals and device input buffers and output drivers. Taking CKE low provides Precharge Power-Down and Self-Refresh operation (all banks idle), or Active Power-Down (row Active in any bank). CKE is synchronous for power down entry and exit and for self-refresh entry. Input buffers excluding CKE are disabled during self-refresh. CKE is used asynchronously to detect self-refresh exit condition. Self-refresh termination itself is synchronous. After VREF has become stable during power-on and initialization sequence, it must be maintained for proper operation of the CKE receiver. For proper self-refresh entry and exit, VREF must be maintained to this input. CKE must be maintained high throughout read and write accesses. Input buffers, excluding CK, $\overline{\text{CK}}$ , ODT and CKE are disabled during dower-down.
$\overline{\text{CS}}$	Input	<b>Chip Select:</b> All command are masked when $\overline{\text{CS}}$ is registered high. $\overline{\text{CS}}$ provides for external rank selection on systems with multiple memory ranks. $\overline{\text{CS}}$ is considered part of the command code.
$\overline{\text{RAS}}$ , $\overline{\text{CAS}}$ , $\overline{\text{WE}}$	Input	<b>Command Inputs:</b> $\overline{\text{RAS}}$ , $\overline{\text{CAS}}$ and $\overline{\text{WE}}$ (along with $\overline{\text{CS}}$ ) define the command being entered
DM, LDM, UDM	Input	<b>Input Data Mask:</b> DM is an input mask signal for write data. Input data is masked when DM is sampled high coincident with that input data during a Write access. DM is sampled on both edges of DQS. Although DM pins are input only, the DM loading matches the DQ and DQS loading. LDM and UDM are the input mask signals for x16 components and control the lower or upper bytes. For x8 components the data mask function is disabled, when RDQS / RQDS are enabled by EMRS(1) command.
BA0, BA1	Input	<b>Bank Address Inputs:</b> BA0 and BA1 define to which bank an Activate, Read, Write or Precharge command is being applied. BA0 and BA1 also determines if the mode register or extended mode register is to be accessed during a MRS or EMRS(1) cycle.
A0 - A12	Input	<b>Address Inputs:</b> Provides the row address for Activate commands and the column address and Auto-Precharge bit A10 (=AP) for Read/Write commands to select one location out of the memory array in the respective bank. A10 (=AP) is sampled during a Precharge command to determine whether the precharge applies to one bank (A10=low) or all banks (A10=high). If only one bank is to be precharged, the bank is selected by BA0 and BA1. The address inputs also provide the op-code during Mode Register Set commands.
DQx, LDQx,UDQx	Input/ Output	<b>Data Inputs/Output:</b> Bi-directional data bus. DQ0~DQ3 for x4 components, DQ0~DQ7 for x8 components, LDQ0~LDQ7 and UDQ0~UDQ7 for x16 components
DQS, ( $\overline{\text{DQS}}$ ) LDQS, ( $\overline{\text{LDQS}}$ ), UDQS, ( $\overline{\text{UDQS}}$ )	Input/ Output	<b>Data Strobe:</b> output with read data, input with write data. Edge aligned with read data, centered with write data. For the x16, LDQS corresponds to the data on LDQ0 - LDQ7; UDQS corresponds to the data on UDQ0-UDQ7. The data strobes DQS, LDQS, UDQS may be used in single ended mode or paired with the optional complementary signals $\overline{\text{DQS}}$ , $\overline{\text{LDQS}}$ , $\overline{\text{UDQS}}$ to provide differential pair signaling to the system during both reads and writes. An EMRS(1) control bit enables or disables the complementary data strobe signals.
RDQS, ( $\overline{\text{RDQS}}$ )	Input/ Output	<b>Read Data Strobe:</b> For the x8 components a RDQS, $\overline{\text{RDQS}}$ pair can be enabled via the EMRS(1) for read timing. RDQS, $\overline{\text{RDQS}}$ is not supported on x4 and x16 components. RDQS, $\overline{\text{RDQS}}$ are edge-aligned with read data. If RDQS, $\overline{\text{RDQS}}$ is enabled, the DM function is disabled on x8 components.
ODT	Input	<b>On Die Termination:</b> ODT (registered HIGH) enables termination resistance internal to the DDR2 SDRAM. When enabled, ODT is applied to each DQ, DQS, $\overline{\text{DQS}}$ and DM signal for x4 and DQ, $\overline{\text{DQS}}$ , $\overline{\text{DQS}}$ , RDQS, $\overline{\text{RDQS}}$ and DM for x8 configurations. For x16 configuration ODT is applied to each DQ, UDQS, $\overline{\text{UDQS}}$ , LDQS, $\overline{\text{LDQS}}$ , UDM and LDM signal. The ODT pin will be ignored if the Extended Mode Register (EMRS(1)) is programmed to disable ODT.
NC		<b>No Connect:</b> no internal electrical connection is present
VDDQ	Supply	<b>DQ Power Supply:</b> 1.8V +/- 0.1V
VSSQ	Supply	<b>DQ Ground</b>
VDDL	Supply	<b>DLL Power Supply:</b> 1.8V +/- 0.1V
VSSDL	Supply	<b>DLL Ground</b>
VDD	Supply	<b>Power Supply:</b> 1.8V +/- 0.1V
VSS	Supply	<b>Ground</b>
VREF	Supply	<b>Reference Voltage</b>
(BA2), (A13~A15)	NC	<b>No Connects:</b> BA2, A13 ~ A15 are additional address pins for future generation DRAMs and are not connected on the components describes in this datasheet.

## 1.6 Block Diagrams

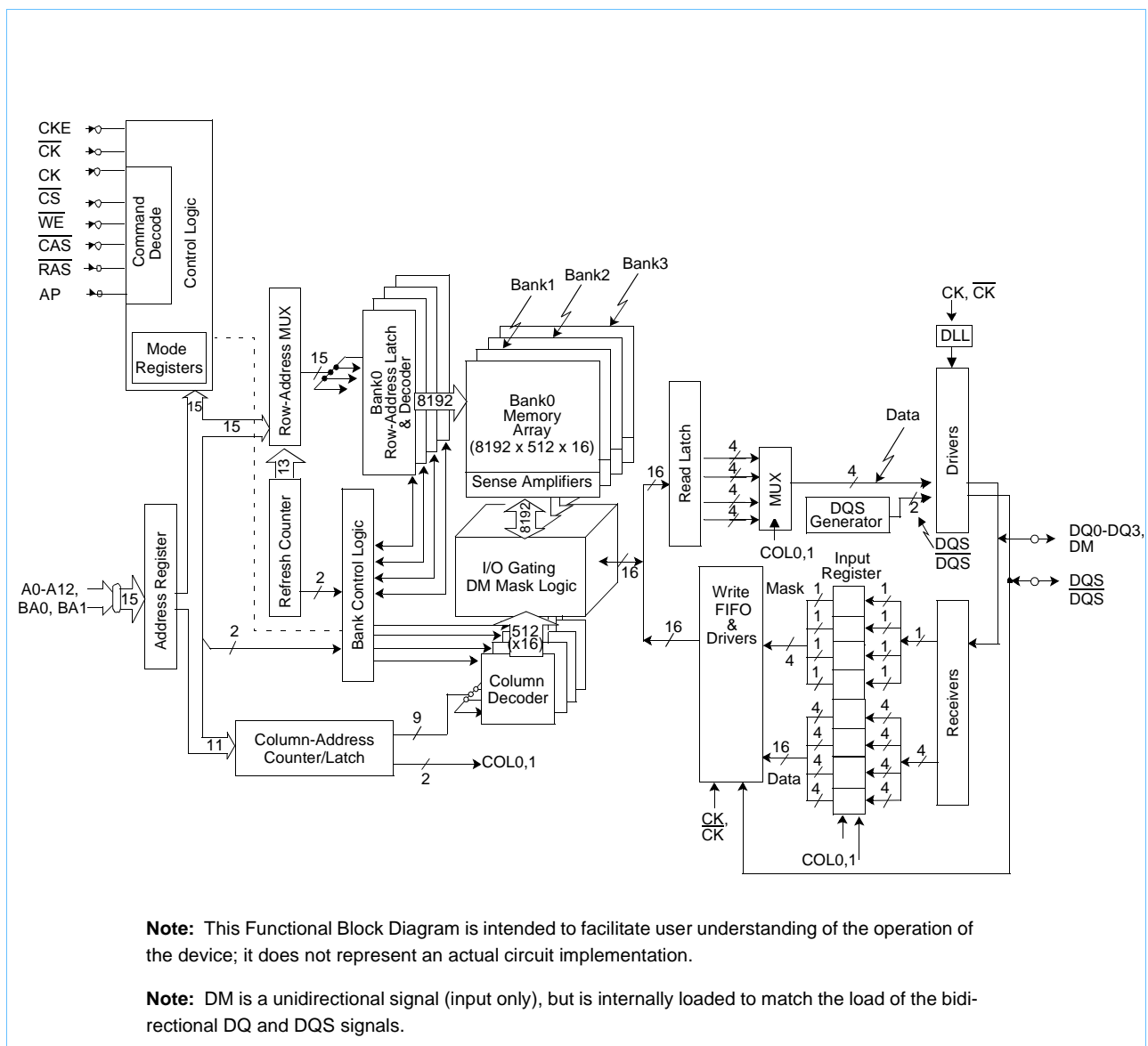

**Block Diagram 16Mbit x 4 I/O x 4 Internal Memory Banks,  
 (64 Mbit x 4 Organisation with 13 Row, 2 Bank and 11 Column External Addresses)**

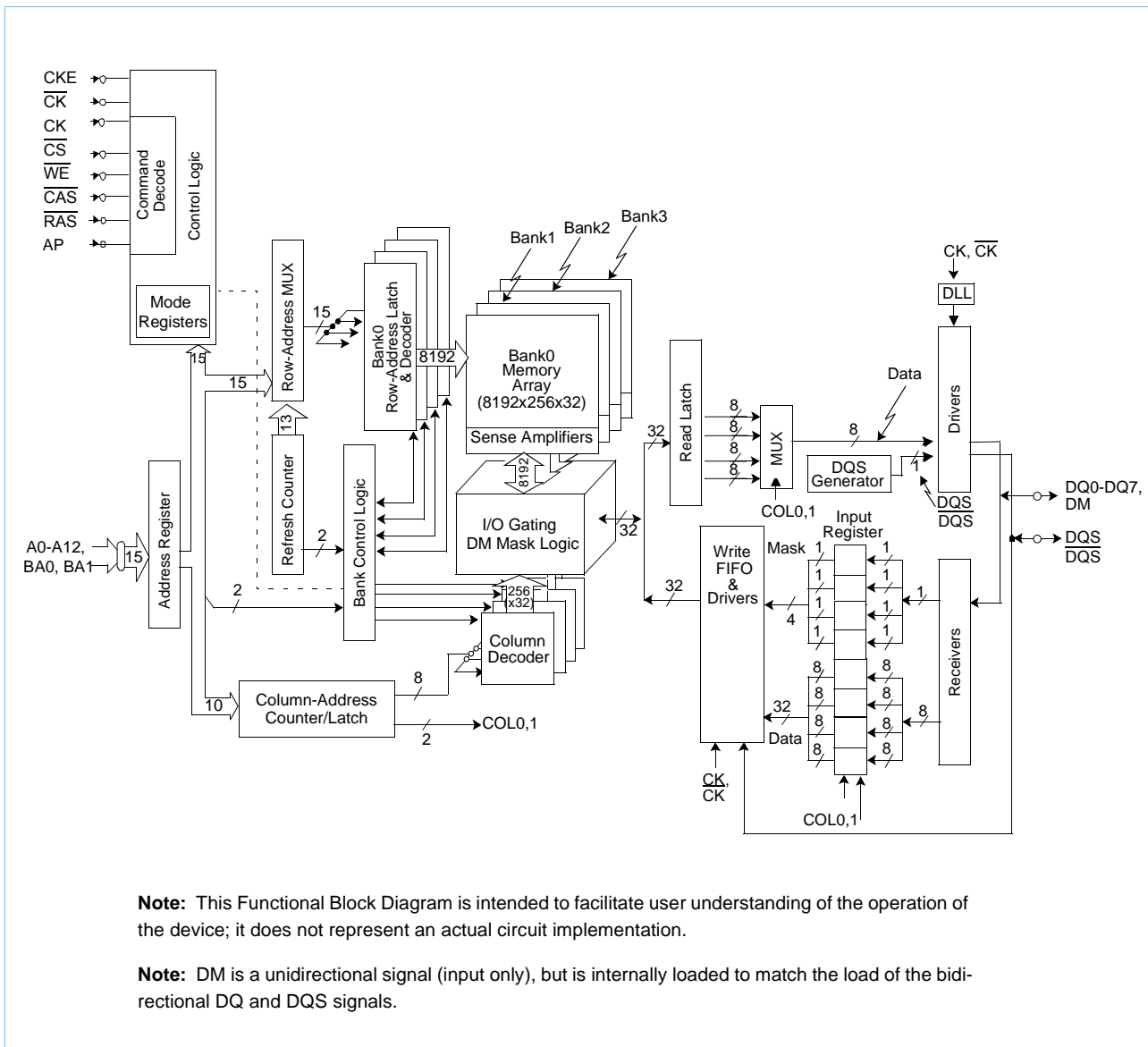

**Block Diagram 8Mbit x 8 I/O x 4 Internal Memory Banks**

**(32Mb x 8 Organisation with 13 Row, 2 Bank and 10 Column External Addresses)**

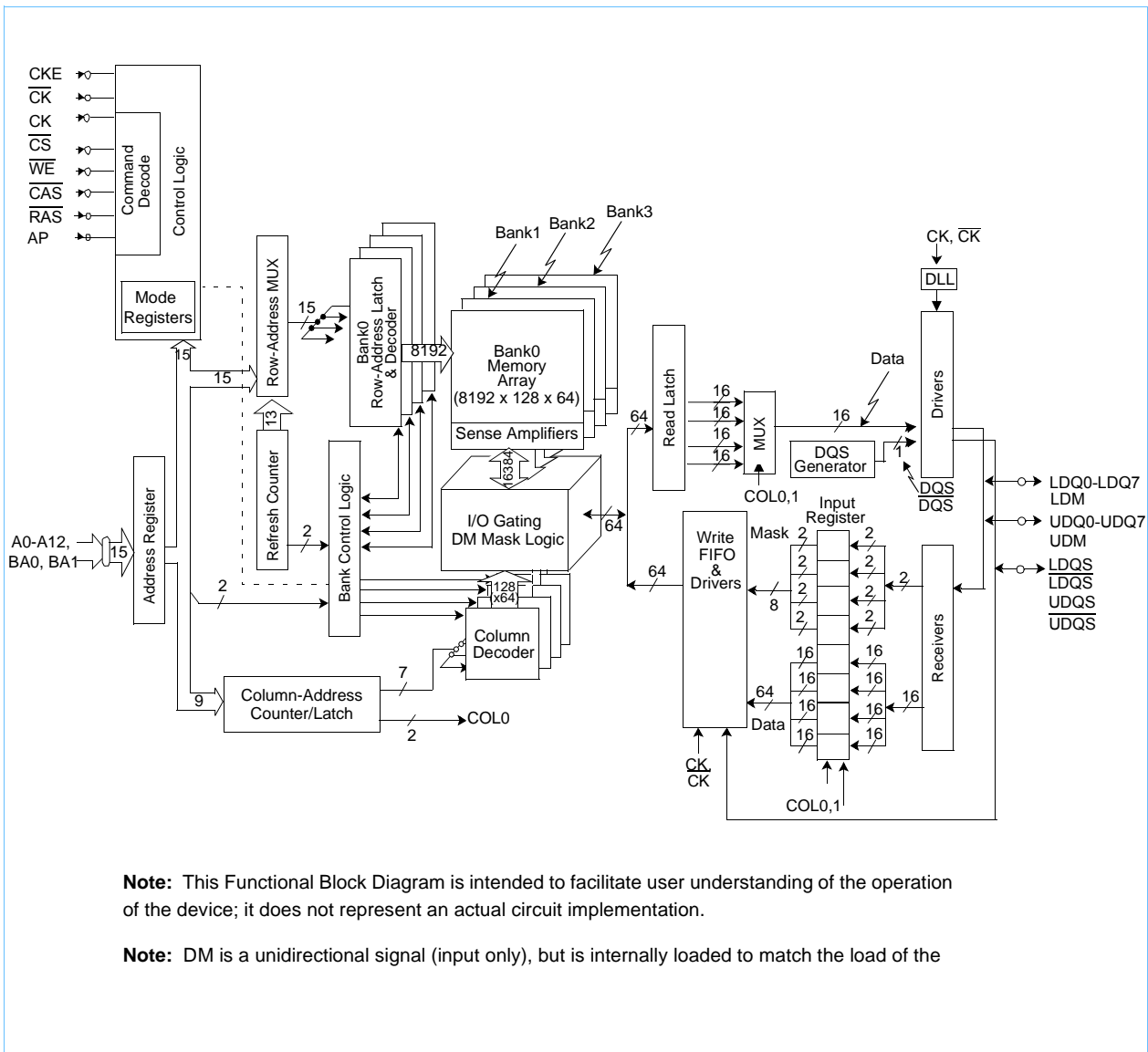

**Block Diagram 4Mbit x 16 I/O x 4 Internal Memory Banks**

**(16Mb x 16 Organisation with 13 Row, 2 Bank and 9 Column External Addresses)**

## 2. Functional Description

### 2.1 Simplified State Diagram

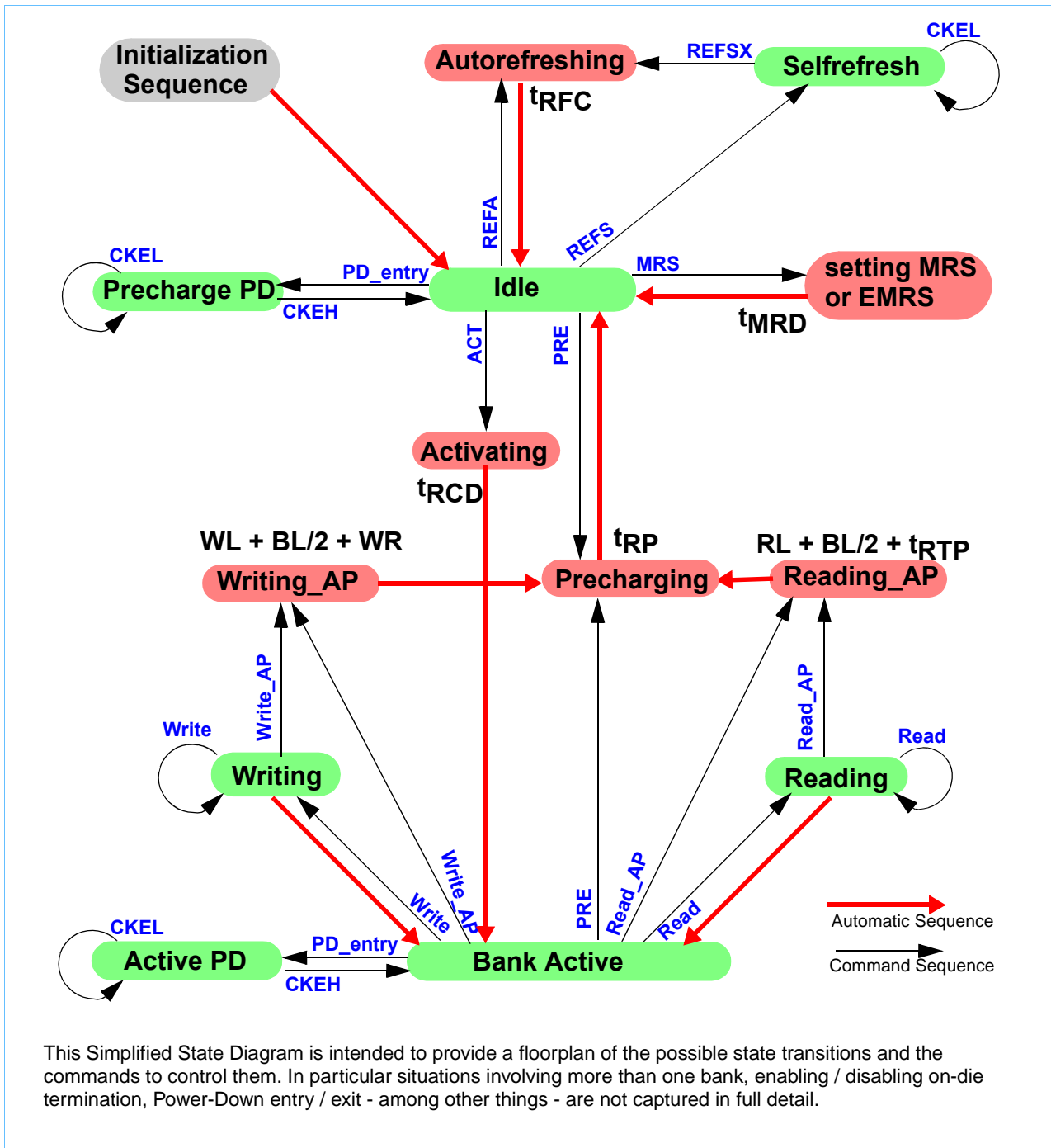

## 2.2 Basic Functionality

Read and write accesses to the DDR2 SDRAM are burst oriented; accesses start at a selected location and continue for the burst length of four or eight in a programmed sequence. Accesses begin with the registration of an Activate command, which is followed by a Read or Write command. The address bits registered coincident with the activate command are used to select the bank and row to be accessed (BA0 & BA1 select the bank, A0-A12 select the row). The address bits registered coincident with the Read or Write command are used to select the starting column location for the burst access and to determine if the Auto-Precharge command is to be issued. Prior to normal operation, the DDR2 SDRAM must be initialized. The following sections provide detailed information covering device initialization, register definition, command description and device operation.

### 2.2.1 Power On and Initialization

DDR2 SDRAMs must be powered up and initialized in a predefined manner. Operational procedures other than those specified may result in undefined operation. Power-Up and Initialization Sequence

The following sequence is required for POWER UP and Initialization.

1. Apply power and attempt to maintain CKE below  $0.2 * VDDQ$  and ODT at a low state (all other inputs may be undefined). To guarantee ODT off, VREF must be valid and a low level must be applied to the ODT pin. Maximum power up interval for VDD/VDDQ is specified as 10.0 ms. The power interval is defined as the amount of time it takes for VDD / VDDQ to power-up from 0V to 1.8 V +/- 100 mV.

- VDD, VDDL and VDDQ are driven from a single power converter output, AND
- VTT is limited to 0.95 V max, AND
- VREF tracks VDDQ/2
- or
- Apply VDD before or at the same time as VDDL,
- Apply VDDL before or at the same time as VDDQ.
- Apply VDDQ before or at the same time as VTT & VREF.

at least one of these two sets of conditions must be met.

2. Start clock (CK,  $\overline{CK}$ ) and maintain stable power and clock condition for a minimum of 200  $\mu$ s.
3. Apply NOP or Deselect commands & take CKE high.
4. Wait minimum of 400ns, then issue a Precharge-All command.
5. Issue EMRS(2) command. (To issue EMRS(2) command, provide "low" to BA0 and BA2 and "high" to BA1)
6. Issue EMRS(3) command. (To issue EMRS(3) command, provide "low" to BA2 and "high" to BA0 and BA1)
7. Issue EMRS(1) command to enable DLL. (To issue "DLL Enable" command, provide "low" to A0 and "high" to BA0 and "low" to BA1, BA2 and A13~A15)
8. Issue MRS command (Mode Register Set) for "DLL reset". (To issue DLL reset command, provide "high" to A8 and "low" to BA0 ~ BA2 and A13 ~ A15)
9. Issue Precharge-All command.
10. Issue 2 or more Auto-Refresh commands.
11. Issue a MRS command with low on A8 to initialize device operation. (i.e. to program operating parameters without resetting the DLL)
12. At least 200 clocks after step 8, execute OCD Calibration (Off Chip Driver impedance adjustment). If OCD calibration is not used, EMRS OCD Default command (A9=A8=A7=1) followed by EMRS(1) OCD Calibration Mode Exit command (A9=A8=A7=0) must be issued with other parameters of EMRS(1).
13. The DDR2 SDRAM is now ready for normal operation.

**Example:**

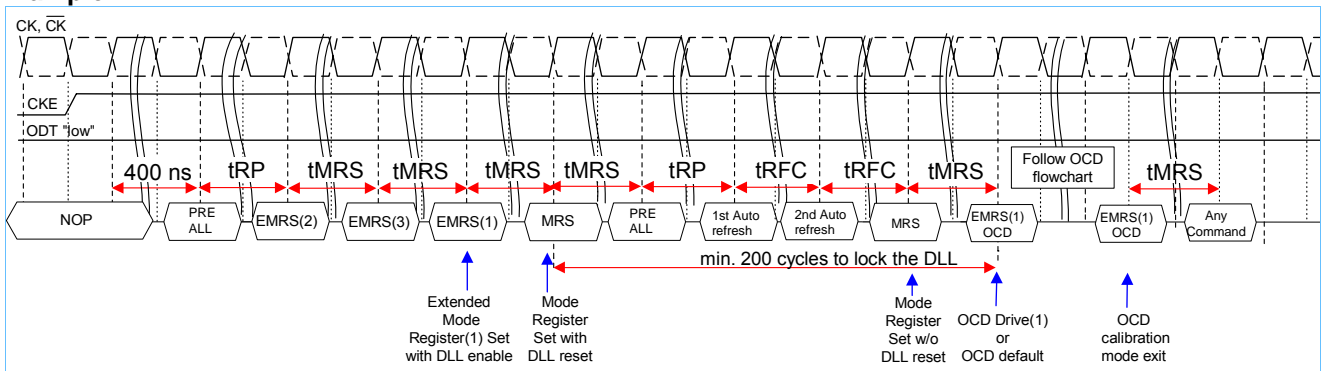

**2.2.2 Programming the Mode Register and Extended Mode Registers**

For application flexibility, burst length, burst type,  $\overline{\text{CAS}}$  latency, DLL reset function, write recovery time (WR) are user defined variables and must be programmed with a Mode Register Set (MRS) command. Additionally, DLL disable function, additive  $\overline{\text{CAS}}$  latency, driver impedance, ODT (On Die Termination), single-ended strobe and OCD (off chip driver impedance adjustment) are also user defined variables and must be programmed with an Extended Mode Register Set (EMRS) command. Contents of the Mode Register (MRS) and Extended Mode Registers (EMRS(#)) can be altered by re-executing the MRS and EMRS Commands. If the user chooses to modify only a subset of the MRS or EMRS variables, all variables must be redefined when the MRS or EMRS commands are issued. Also any programming of EMRS(2) or EMRS(3) must be followed by programming of MRS and EMRS(1). After initial power up, all MRS and EMRS Commands must be issued before read or write cycles may begin. All banks must be in a precharged state and CKE must be high at least one cycles before the Mode Register Set Command can be issued. Either MRS or EMRS Commands are activated by the low signals of  $\overline{\text{CS}}$ ,  $\overline{\text{RAS}}$ ,  $\overline{\text{CAS}}$  and  $\overline{\text{WE}}$  at the positive edge of the clock. When both bank addresses BA0 and BA1 are low, the DDR2 SDRAM enables the MRS command. When the bank addresses BA0 is high and BA1 low, the DDR2 SDRAM enables the EMRS(1) command. The address input data during this cycle defines the parameters to be set as shown in the MRS and EMRS table. A new command may be issued after the mode register set command cycle time ( $t_{\text{MRD}}$ ). MRS, EMRS and DLL Reset do not affect array contents, which means re-initialization including those can be executed any time after power-up without affecting array contents.

**2.2.3 DDR2 SDRAM Mode Register Set (MRS)**

The mode register stores the data for controlling the various operating modes of DDR2 SDRAM. It programs  $\overline{\text{CAS}}$  latency, burst length, burst sequence, test mode, DLL reset, WR (write recovery) and various vendor specific options to make DDR2 SDRAM useful for various applications. The default value of the mode register is not defined, therefore the mode register must be written after power-up for proper operation. The mode register is written by asserting low on  $\overline{\text{CS}}$ ,  $\overline{\text{RAS}}$ ,  $\overline{\text{CAS}}$ ,  $\overline{\text{WE}}$ , BA0 and BA1, while controlling the state of address pins A0 ~ A13. The DDR2 SDRAM should be in all bank precharge (idle) mode with CKE already high prior to writing into the mode register. The mode register set command cycle time ( $t_{\text{MRD}}$ ) is required to complete the write operation to the mode register. The mode register contents can be changed using the same command and clock cycle requirements during normal operation as long as all banks are in the precharge state. The mode register is divided into various fields depending on functionality. Burst length is defined by A0 ~ A2 with options of 4 and 8 bit burst length. Burst address sequence type is defined by A3 and  $\overline{\text{CAS}}$  latency is defined by A4 ~ A6. A7 is used for test mode and must be set to low for normal MRS operation. A8 is used for DLL reset. A9 ~ A11 are used for write recovery time (WR) definition for Auto-Precharge mode. With address bit A12 two Power-Down modes can be selected, a "standard mode" and a "low-power" Power-Down mode, where the DLL is disabled. Address bit A13 and all "higher" address bits (including BA2) have to be set to "low" for compatibility with other DDR2 memory products with higher memory densities.

**MRS Mode Register Operation Table (Address Input For Mode Set)**

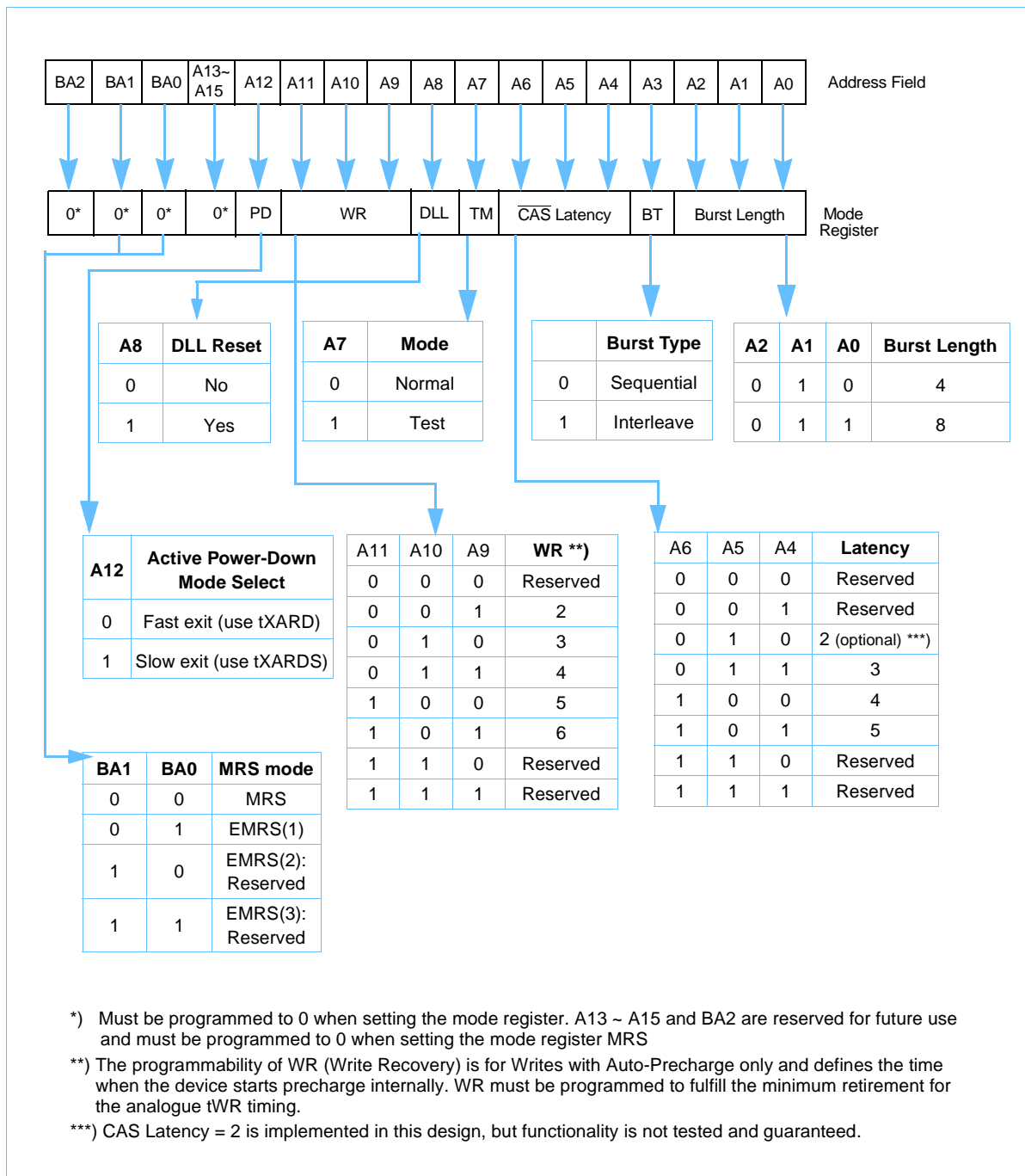



### 2.2.4 DDR2 SDRAM Extended Mode Register Set (EMRS(1))

The extended mode register EMRS(1) stores the data for enabling or disabling the DLL, output driver strength, additive latency, OCD program, ODT,  $\overline{DQS}$  and output buffers disable, RQDS and  $\overline{RDQS}$  enable. The default value of the extended mode register EMRS(1) is not defined, therefore the extended mode register must be written after power-up for proper operation. The extended mode register is written by asserting low on  $\overline{CS}$ ,  $\overline{RAS}$ ,  $\overline{CAS}$ ,  $\overline{WE}$ , BA1 and high on BA0, while controlling the state of the address pins. The DDR2 SDRAM should be in all bank precharge with CKE already high prior to writing into the extended mode register. The mode register set command cycle time (tMRD) must be satisfied to complete the write operation to the EMRS(1). Mode register contents can be changed using the same command and clock cycle requirements during normal operation as long as all banks are in precharge state.

#### EMRS(1) Extended Mode Register Operation Table (Address Input For Mode Set)

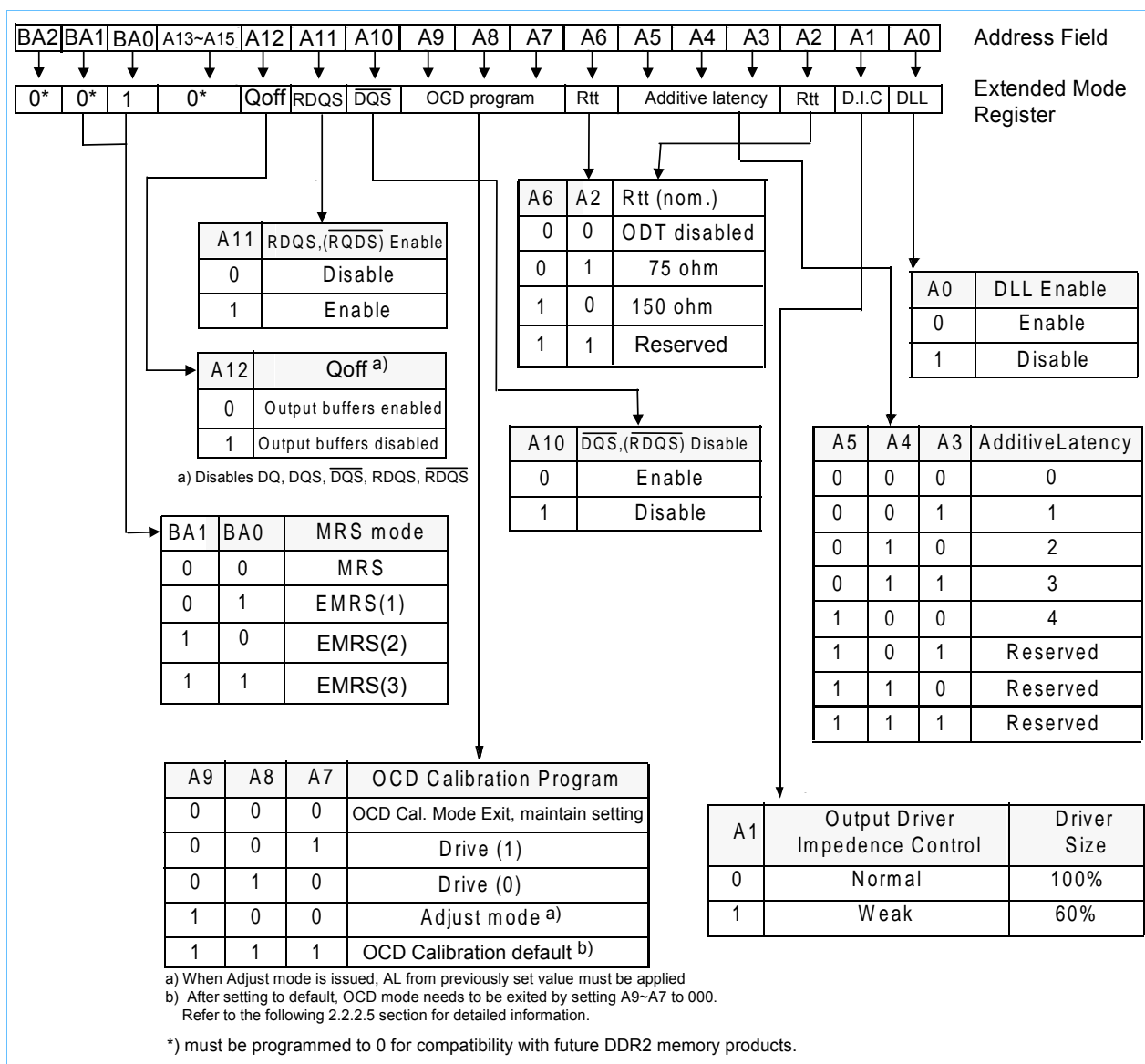

A0 is used for DLL enable or disable. A1 is used for enabling half-strength data-output driver. A2 and A6 enables ODT (On-Die termination) and sets the Rtt value. A3~A5 are used for additive latency settings and A7 ~ A9 enables the OCD impedance adjustment mode. A10 enables or disables the differential DQS and RDQS signals, A11 disables or enables RDQS. Address bit A12 have to be set to “low” for normal operation. With A12 set to “high” the SDRAM outputs are disabled and in Hi-Z. “High” on BA0 and “low” for BA1 have to be set to access the EMRS(1). A13 and all “higher” address bits (including BA2) have to be set to “low” for compatibility with other DDR2 memory products with higher memory densities. Refer to the table for specific codes on the previous page.

**Single-ended and Differential Data Strobe Signals**

The following table lists all possible combinations for DQS,  $\overline{DQS}$ , RDQS,  $\overline{RDQS}$  which can be programmed by A10 & A11 address bits in EMRS(1). RDQS and  $\overline{RDQS}$  are available in x8 components only. If RDQS is enabled in x8 components, the DM function is disabled. RDQS is active for reads and don't care for writes:

EMRS(1)		Strobe Function Matrix				Signaling
A11 (RDQS Enable)	A10 ( $\overline{DQS}$ Enable)	RDQS/DM	$\overline{RDQS}$	DQS	$\overline{DQS}$	
0 (Disable)	0 (Enable)	DM	Hi-Z	DQS	$\overline{DQS}$	differential DQS signals
0 (Disable)	1 (Disable)	DM	Hi-Z	DQS	Hi-Z	single-ended DQS signals
1 (Enable)	0 (Enable)	RDQS	$\overline{RDQS}$	DQS	$\overline{DQS}$	differential DQS signals
1 (Enable)	1 (Disable)	RDQS	Hi-Z	DQS	Hi-Z	single-ended DQS signals

**DLL Enable/Disable**

The DLL must be enabled for normal operation. DLL enable is required during power up initialization, and upon returning to normal operation after having the DLL disabled. The DLL is automatically disabled when entering Self-Refresh operation and is automatically re-enabled and reset upon exit of Self-Refresh operation. Any time the DLL is reset, 200 clock cycles must occur before a Read command can be issued to allow time for the internal clock to be synchronized with the external clock. Less clock cycles may result in a violation of the tAC or tDQSCK parameters.

**Output Disable (Qoff)**

Under normal operation, the DRAM outputs are enabled during Read operation for driving data (Qoff bit in the EMRS(1) is set to 0). When the Qoff bit is set to 1, the DRAM outputs will be disabled. Disabling the DRAM outputs allows users to measure IDD currents during Read operations, without including the output buffer current.

### 2.2.5 EMRS(2) Extended Mode Register

The Extended Mode Registers EMRS(2) and EMRS(3) are reserved for future use and must be programmed when setting the mode register during initialization.

The extended mode register EMRS(2) is written by asserting low on  $\overline{CS}$ ,  $\overline{RAS}$ ,  $\overline{CAS}$ ,  $\overline{WE}$ , BA2, BA0 and high on BA1, while controlling the state of the address pins. The DDR2 SDRAM should be in all bank precharge with CKE already high prior to writing into the extended mode register. The mode register set command cycle time (tMRD) must be satisfied to complete the write operation to the EMRS(2). Mode register contents can be changed using the same command and clock cycle requirements during normal operation as long as all banks are in precharge state

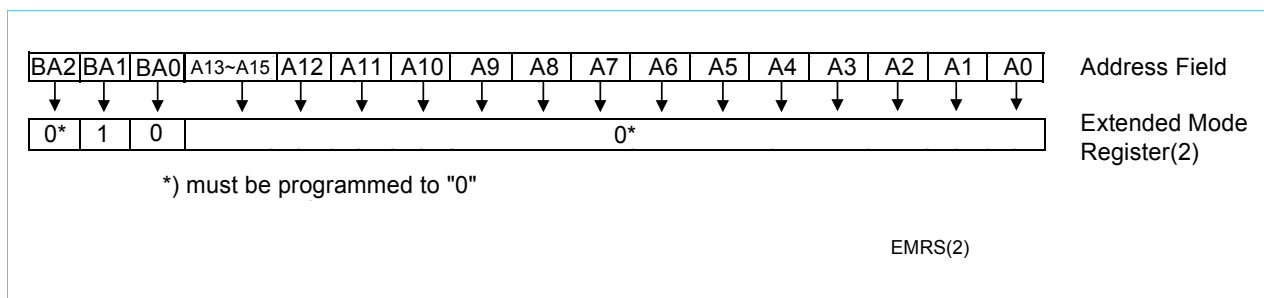

### 2.2.6 EMRS(3) Extended Mode Register

The Extended Mode Register EMRS(3) is reserved for future use and all bits except BA0 and BA1 must be programmed to 0 when setting the mode register during initialization

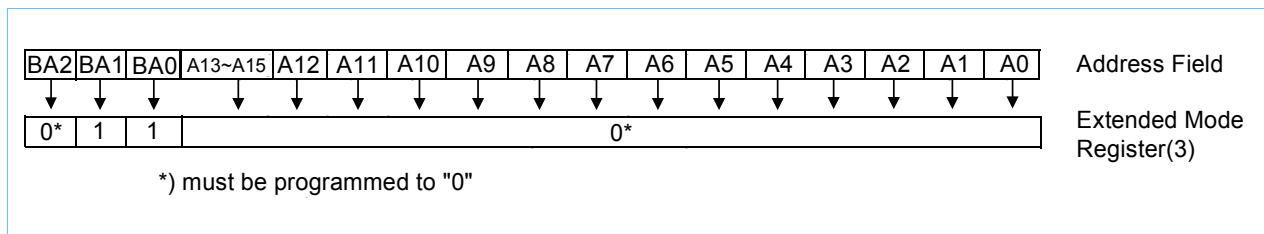

### 2.3 Off-Chip Driver (OCD) Impedance Adjustment

DDR2 SDRAM supports driver calibration feature and the flow chart below is an example of the sequence. Every calibration mode command should be followed by "OCD calibration mode exit" before any other command being issued. MRS should be set before entering OCD impedance adjustment and ODT (On Die Termination) should be carefully controlled depending on system environment.

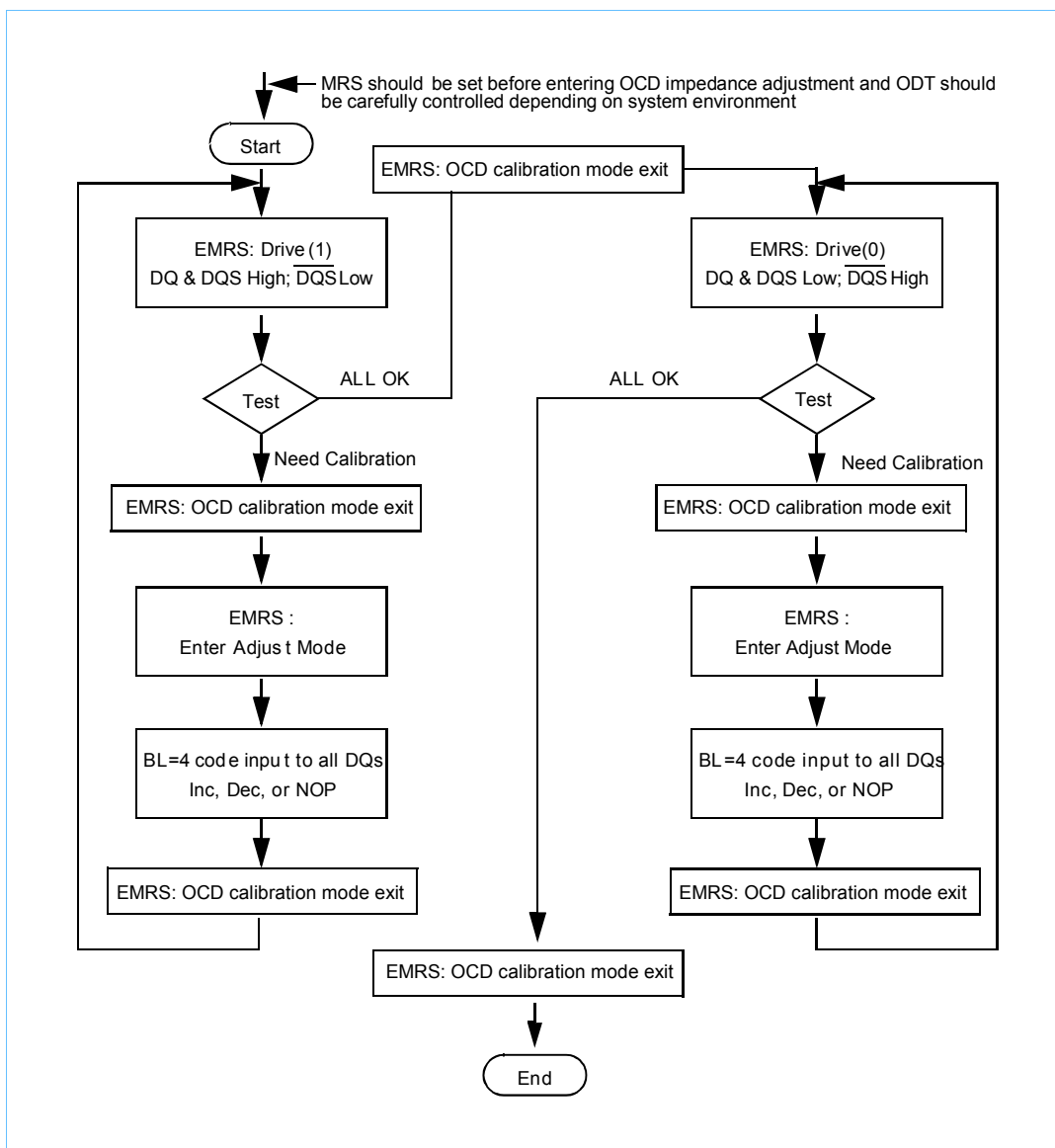

### Extended Mode Register Set for OCD impedance adjustment

OCD impedance adjustment can be done using the following EMRS(1) mode. In drive mode all outputs are driven out by DDR2 SDRAM and drive of RDQS is dependent on EMRS(1) bit enabling RDQS operation. In Drive(1) mode, all DQ, DQS (and RDQS) signals are driven high and all  $\overline{DQS}$  (and  $\overline{RDQS}$ ) signals are driven low. In Drive(0) mode, all DQ, DQS (and RDQS) signals are driven low and all  $\overline{DQS}$  (and  $\overline{RDQS}$ ) signals are driven high. In adjust mode, BL = 4 of operation code data must be used. In case of OCD calibration default, output driver characteristics have a nominal impedance value of 18 Ohms during nominal temperature and voltage conditions. Output driver characteristics for OCD calibration default are specified in the following table. OCD applies only to normal full strength output drive setting defined by EMRS(1) and if half strength is set, OCD default driver characteristics are not applicable. When OCD calibration adjust mode is used, OCD default output driver characteristics are not applicable. After OCD calibration is completed or driver strength is set to default, subsequent EMRS(1) commands not intended to adjust OCD characteristics must specify A7~A9 as '000' in order to maintain the default or calibrated value.

#### Off- Chip-Driver program

A9	A8	A7	Operation
0	0	0	OCD calibration mode exit
0	0	1	Drive(1) DQ, DQS, (RDQS) high and $\overline{DQS}$ , ( $\overline{RDQS}$ ) low
0	1	0	Drive(0) DQ, DQS, (RDQS) low and $\overline{DQS}$ , ( $\overline{RDQS}$ ) high
1	0	0	Adjust mode
1	1	1	OCD calibration default

#### OCD impedance adjust

To adjust output driver impedance, controllers must issue the ADJUST EMRS(1) command along with a 4 bit burst code to DDR2 SDRAM as in the following table. For this operation, Burst Length has to be set to BL = 4 via MRS command before activating OCD and controllers must drive the burst code to all DQs at the same time. DT0 in the table means all DQ bits at bit time 0, DT1 at bit time 1, and so forth. The driver output impedance is adjusted for all DDR2 SDRAM DQs simultaneously and after OCD calibration, all DQs of a given DDR2 SDRAM will be adjusted to the same driver strength setting. The maximum step count for adjustment is 16 and when the limit is reached, further increment or decrement code has no effect. The default setting may be any step within the maximum step count range. When Adjust mode command is issued, AL from previously set value must be applied.

#### Off- Chip-Driver Adjust Program

4 bit burst code inputs to all DQs				Operation	
DT0	DT1	DT2	DT3	Pull-up driver strength	Pull-down driver strength
0	0	0	0	NOP (no operation)	NOP (no operation)
0	0	0	1	Increase by 1 step	NOP
0	0	1	0	Decrease by 1 step	NOP
0	1	0	0	NOP	Increase by 1 step
1	0	0	0	NOP	Decrease by 1 step
0	1	0	1	Increase by 1 step	Increase by 1 step
0	1	1	0	Decrease by 1 step	Increase by 1 step
1	0	0	1	Increase by 1 step	Decrease by 1 step
1	0	1	0	Decrease by 1 step	Decrease by 1 step
Other Combinations				Reserved	Reserved

For proper operation of adjust mode,  $WL = RL - 1 = AL + CL - 1$  clocks and  $tDS / tDH$  should be met as the following timing diagram. Input data pattern for adjustment, DT0 - DT3 is fixed and not affected by MRS addressing mode (i.e. sequential or interleave). Burst length of 4 have to be programmed in the MRS for OCD impedance adjustment.

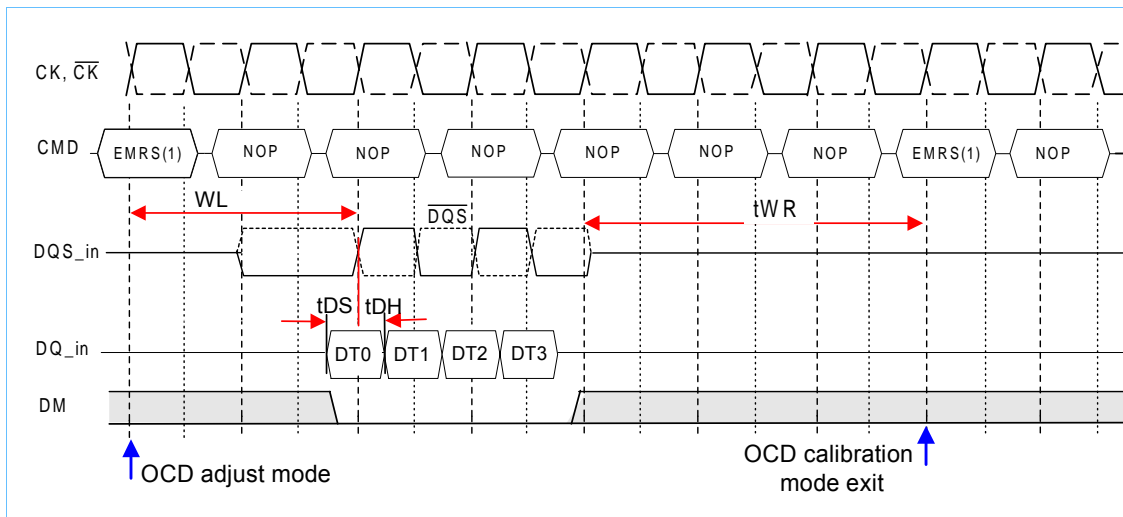

### Drive Mode

Drive mode, both Drive(1) and Drive(0), is used for controllers to measure DDR2 SDRAM Driver impedance before OCD impedance adjustment. In this mode, all outputs are driven out  $tOIT$  after "enter drive mode" command and all output drivers are turned-off  $tOIT$  after "OCD calibration mode exit" command as the following timing diagram.

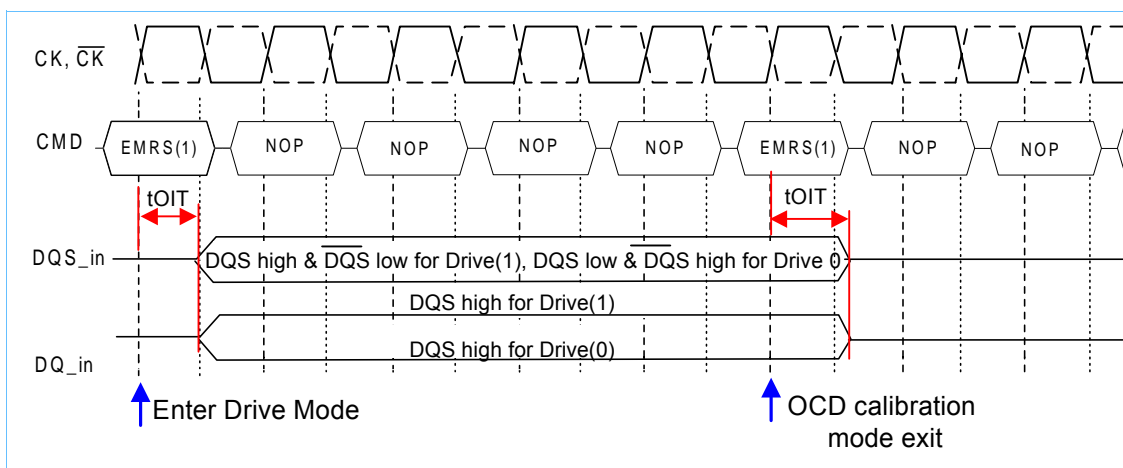

## 2.4 On-Die Termination (ODT)

ODT (On-Die Termination) is a new feature on DDR2 components that allows a DRAM to turn on/off termination resistance for each DQ, DQS,  $\overline{DQS}$  and DM for x4 and DQ, DQ's DM, RDQS (DM and RDQS share the same pin), and  $\overline{RDQS}$  for x8 configuration via the ODT control pin, where  $\overline{DQS}$  is terminated only when enabled in the EMRS(1) by address bit A10 = 0. For x8 configuration  $\overline{RDQS}$  is only terminated, when enabled in the EMRS(1) by address bits A10 = 0 and A11 = 1.

For x16 configuration ODT is applied to each UDQ, LDQ, UDQS,  $\overline{UDQS}$ , LDQS,  $\overline{LDQS}$ , UDM and LDM signal via the ODT control pin, where UDQS and LDQS are terminated only when enabled in the EMRS(1) by address bit A10 = 0.

The ODT feature is designed to improve signal integrity of the memory channel by allowing the DRAM controller to independently turn on/off termination resistance for any or all DRAM devices.

The ODT function can be used for all active and standby modes. ODT is turned off and not supported in Self-Refresh mode.

### Functional Representation of ODT

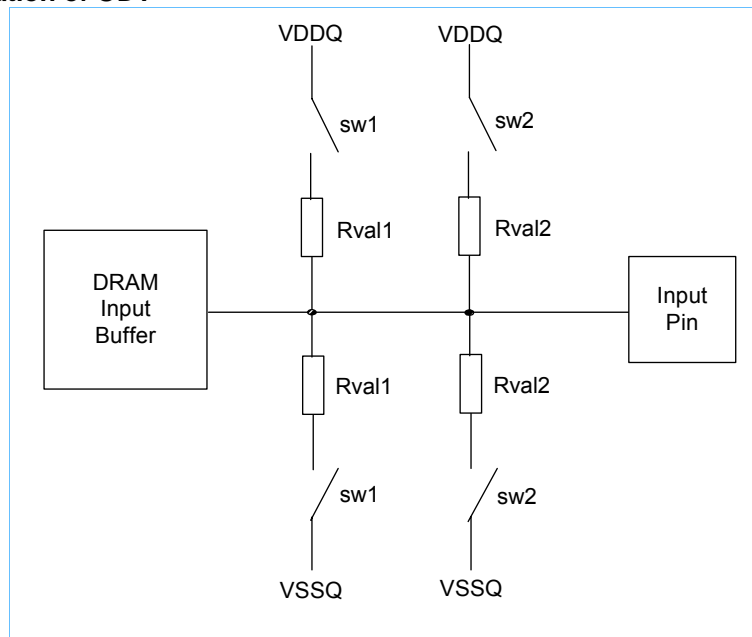

Switch sw1 or sw2 is enabled by the ODT pin. Selection between sw1 or sw2 is determined by "Rtt (nominal)" in EMRS(1) address bits A6 & A2. Target  $R_{tt} = 0.5 * R_{val1}$  or  $0.5 * R_{val2}$ .

The ODT pin will be ignored if the Extended Mode Register (EMRS(1)) is programmed to disable ODT.

## ODT Truth Tables

The ODT Truth Table shows which of the input pins are terminated depending on the state of address bit A10 and A11 in the EMRS(1) for all three device organisations (x4, x8 and x16). To activate termination of any of these pins, the ODT function has to be enabled in the EMRS(1) by address bits A6 and A2.

Input Pin	EMRS(1) Address Bit A10	EMRS(1) Address Bit A11
<b>x4 components:</b>		
DQ0~DQ3	X	X
DQS	X	X
$\overline{DQS}$	0	X
DM	X	X
<b>x8 components:</b>		
DQ0~DQ7	X	X
DQS	X	X
$\overline{DQS}$	0	X
RDQS	X	1
$\overline{RDQS}$	0	1
DM	X	0
<b>x16 components:</b>		
LDQ0~LDQ7	X	X
UDQ0~UDQ7	X	X
LDQS	X	X
$\overline{LDQS}$	0	X
UDQS	X	X
$\overline{UDQS}$	0	X
LDM	X	X
UDM	X	X
X = don't care; 0 = bit set to low; 1 = bit set to high		

## ODT timing modes

Depending on the operating mode synchronous or asynchronous ODT timings apply. Synchronous timings (tAOND, tAOFD, tAON and tAOF) apply for all modes, when the on-die DLL is not disabled.

These modes are:

- Active Mode
- Standby Mode
- Fast Exit Active Power Down Mode (with MRS bit A12 is set to "0")

Asynchronous ODT timings (tAOFPD, tAONPD) apply when the on-die DLL is disabled.

These modes are:

- Slow Exit Active Power Down Mode (with MRS bit A12 is set to "1")
- Precharge Power Down Mode



**ODT Timing for Active and Standby (Idle) Modes**  
**(Synchronous ODT timings)**

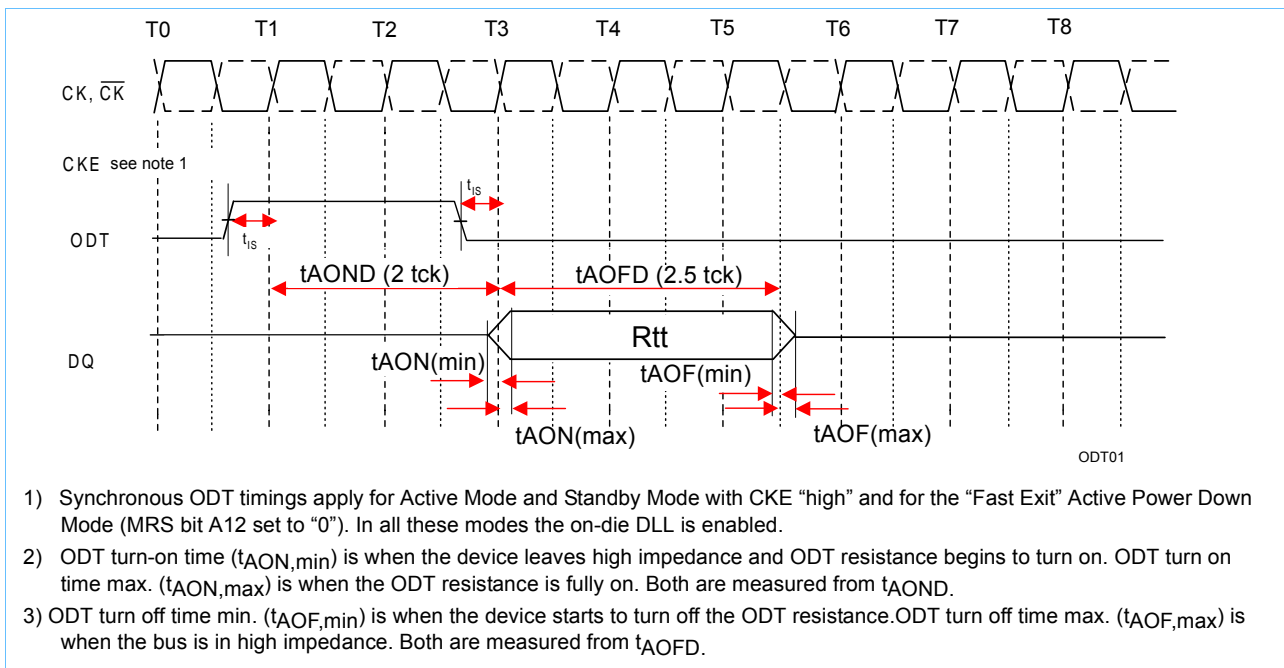

**ODT Timing for Precharge Power-Down and Active Power-Down Mode (with slow exit)**  
**(Asynchronous ODT timings)**

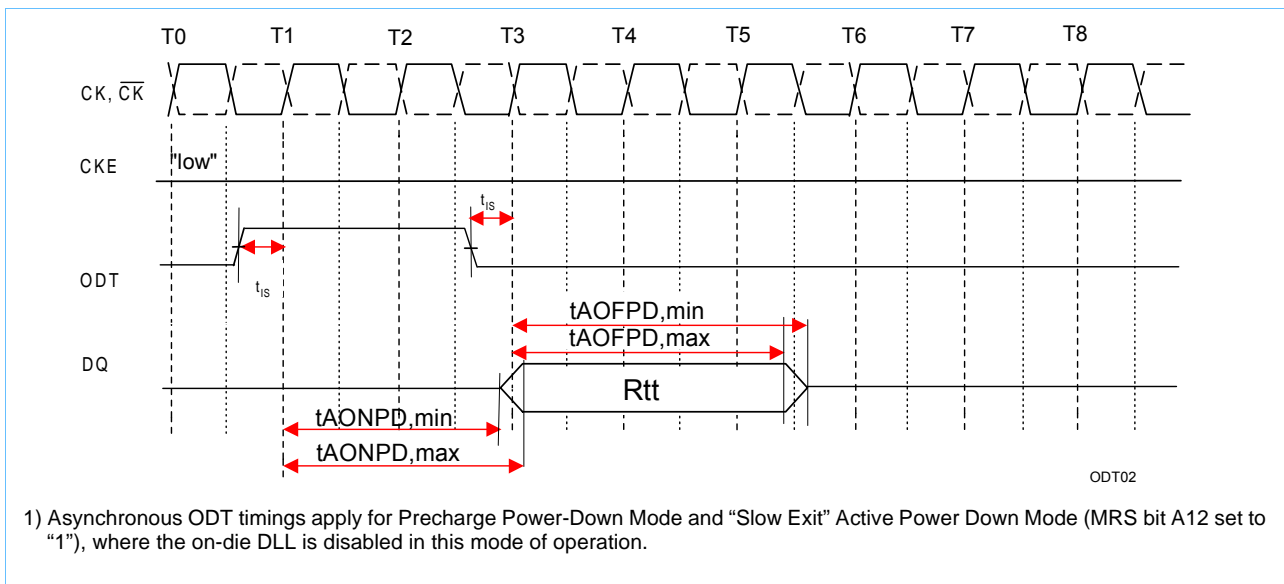

### ODT timing mode switch

When entering the Power Down Modes “Slow Exit” Active Power Down and Precharge Power Down two additional timing parameters ( $t_{ANPD}$  and  $t_{AXPD}$ ) define if synchronous or asynchronous ODT timings have to be applied.

#### Mode entry:

As long as the timing parameter  $t_{ANPDmin}$  is satisfied when ODT is turned on or off before entering these power-down modes, synchronous timing parameters can be applied. If  $t_{ANPDmin}$  is not satisfied, asynchronous timing parameters apply

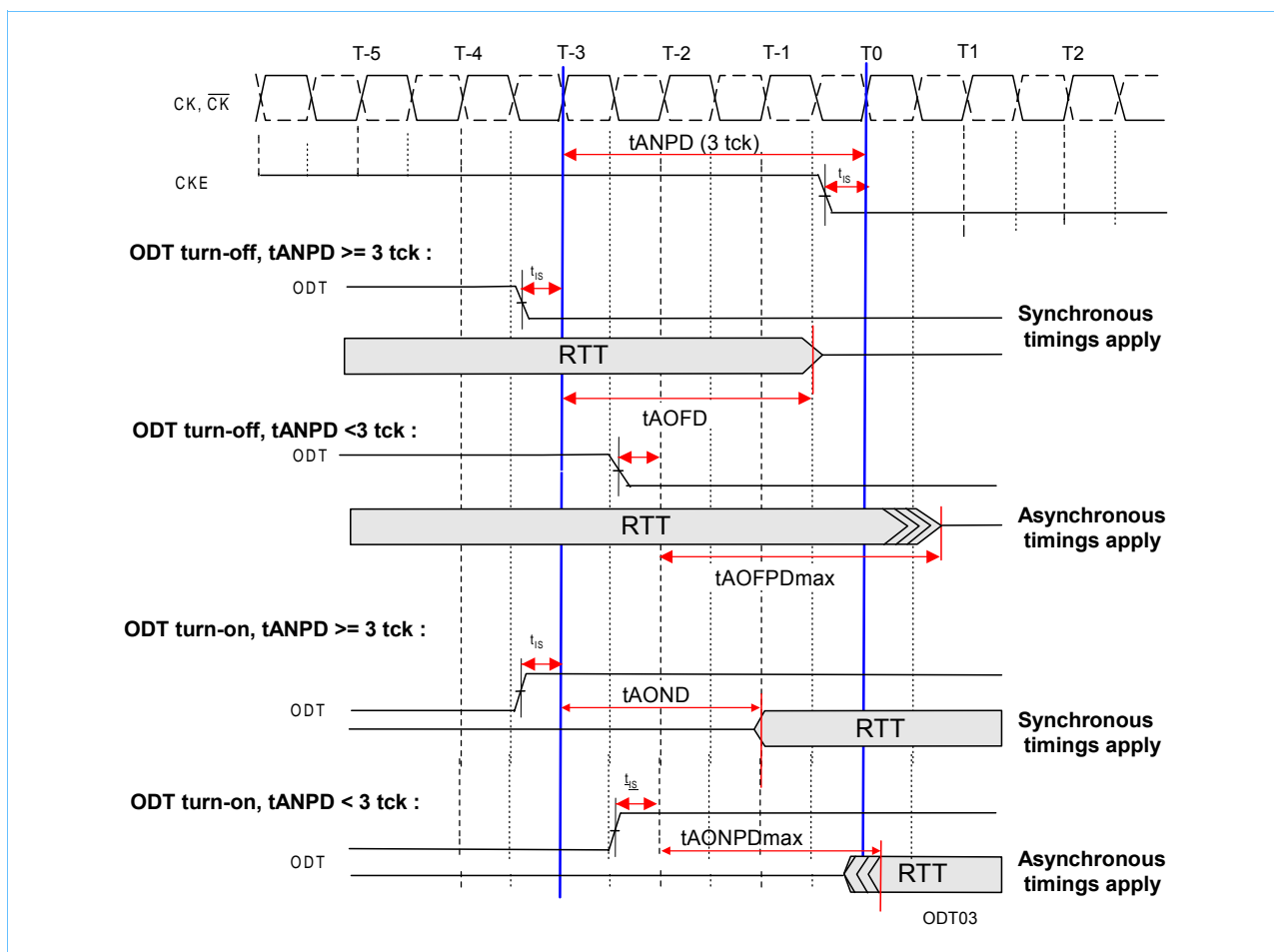

**Mode exit:**

As long as the timing parameter  $t_{AXPDmin}$  is satisfied when ODT is turned on or off after exiting these power-down modes, synchronous timing parameters can be applied. If  $t_{AXPDmin}$  is not satisfied, asynchronous timing parameters apply.

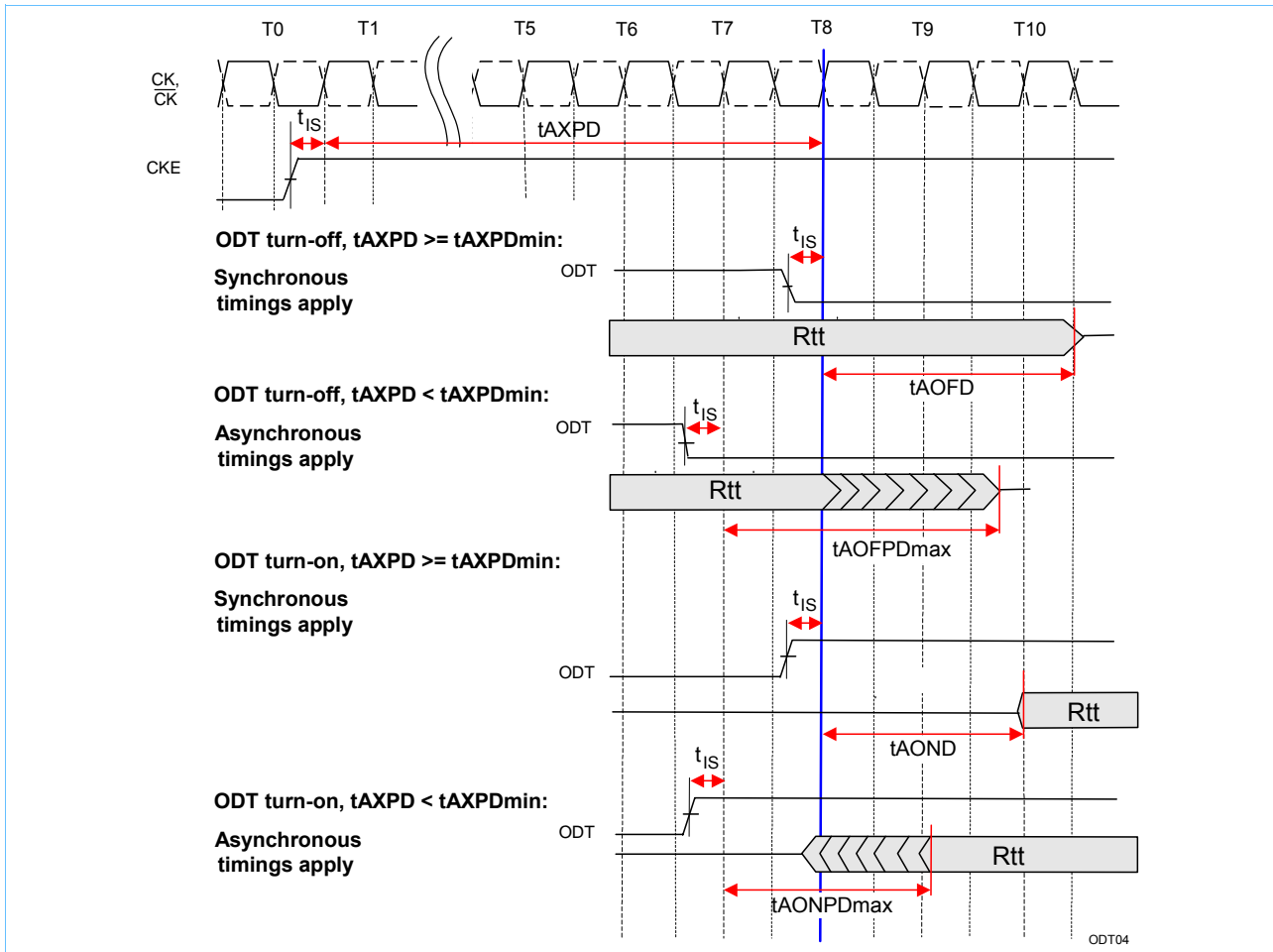

## 2.5 Bank Activate Command

The Bank Activate command is issued by holding  $\overline{\text{CAS}}$  and  $\overline{\text{WE}}$  high with  $\overline{\text{CS}}$  and  $\overline{\text{RAS}}$  low at the rising edge of the clock. The bank addresses BA0 and BA1 are used to select the desired bank. The row addresses A0 through A12 are used to determine which row to activate in the selected bank for x4 and x8 organised components. For x16 components row addresses A0 through A12 have to be applied. The Bank Activate command must be applied before any Read or Write operation can be executed. Immediately after the bank active command, the DDR2 SDRAM can accept a read or write command (with or without Auto-Precharge) on the following clock cycle. If a R/W command is issued to a bank that has not satisfied the  $t_{\text{RCDmin}}$  specification, then additive latency must be programmed into the device to delay the R/W command which is internally issued to the device. The additive latency value must be chosen to assure  $t_{\text{RCDmin}}$  is satisfied. Additive latencies of 0, 1, 2, 3 and 4 are supported. Once a bank has been activated it must be precharged before another Bank Activate command can be applied to the same bank. The bank active and precharge times are defined as  $t_{\text{RAS}}$  and  $t_{\text{RP}}$ , respectively. The minimum time interval between successive Bank Activate commands to the same bank is determined ( $t_{\text{RC}}$ ). The minimum time interval between Bank Active commands, to any other bank, is the Bank A to Bank B delay time ( $t_{\text{RRD}}$ ).

### Bank Activate Command Cycle: $t_{\text{RCD}} = 3$ , $\text{AL} = 2$ , $t_{\text{RP}} = 3$ , $t_{\text{RRD}} = 2$

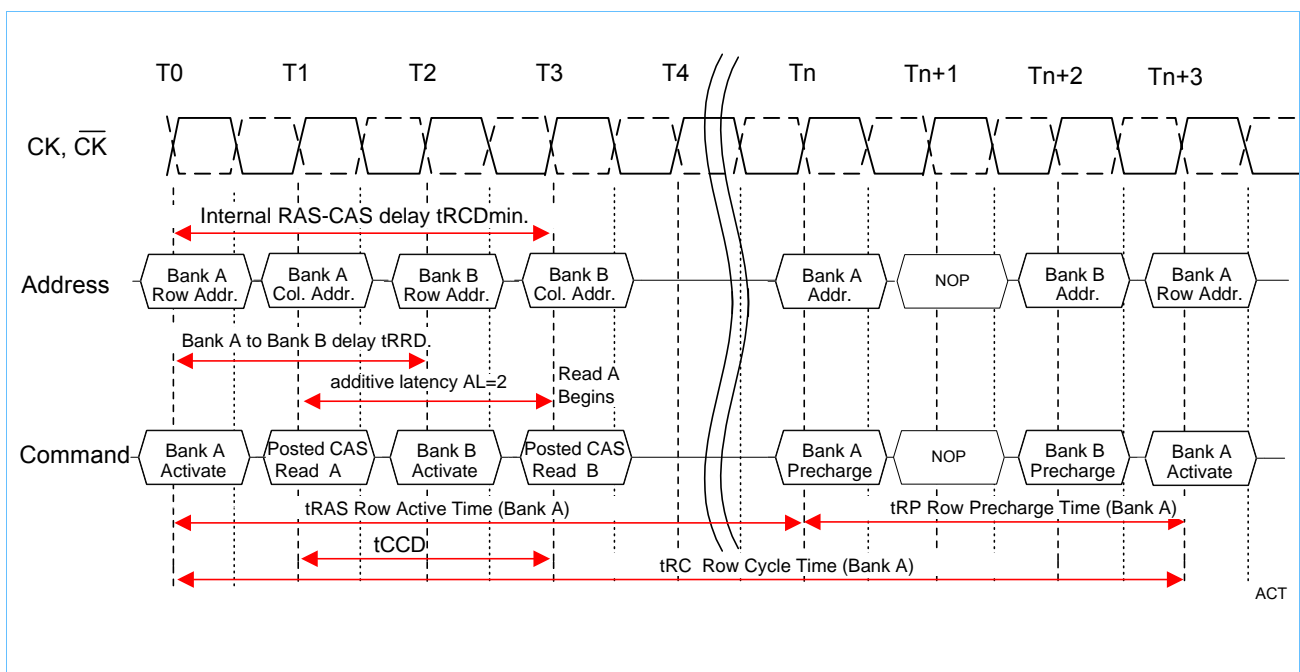

## 2.6 Read and Write Commands and Access Modes

After a bank has been activated, a read or write cycle can be executed. This is accomplished by setting  $\overline{\text{RAS}}$  high,  $\overline{\text{CS}}$  and  $\overline{\text{CAS}}$  low at the clock's rising edge.  $\overline{\text{WE}}$  must also be defined at this time to determine whether the access cycle is a read operation ( $\overline{\text{WE}}$  high) or a write operation ( $\overline{\text{WE}}$  low). The DDR2 SDRAM provides a wide variety of fast access modes. A single Read or Write Command will initiate a serial read or write operation on successive clock cycles at data rates of up to 667Mb/sec/pin for main memory. The boundary of the burst cycle is restricted to specific segments of the page length.

For example, the 16Mbit x 4 I/O x 4 Bank chip has a page length of 2048 bits (defined by CA0-CA9 & CA11). In case of a 4-bit burst operation (burst length = 4) the page length of 2048 is divided into 512 uniquely addressable segments (4-bits x 4 I/O each). The 4-bit burst operation will occur entirely within one of the 512 segments (defined by CA0-CA8) beginning with the column address supplied to the device during the Read or Write Command (CA0-CA9 & A11). The second, third and fourth access will also occur within this segment, however, the burst order is a function of the starting address, and the burst sequence.

In case of a 8-bit burst operation (burst length = 8) the page length of 2048 is divided into 256 uniquely addressable double segments (8-bits x 4 I/O each). The 8-bit burst operation will occur entirely within one of the 256 double segments (defined by CA0-CA7) beginning with the column address supplied to the device during the Read or Write Command (CA0-CA9 & CA11).

A new burst access must not interrupt the previous 4 bit burst operation in case of BL = 4 setting. Therefore the minimum  $\overline{\text{CAS}}$  to  $\overline{\text{CAS}}$  delay ( $t_{\text{CCD}}$ ) is a minimum of 2 clocks for read or write cycles.

For 8 bit burst operation (BL = 8) the minimum  $\overline{\text{CAS}}$  to  $\overline{\text{CAS}}$  delay ( $t_{\text{CCD}}$ ) is 4 clocks for read or write cycles. Burst interruption is allowed with 8 bit burst operation. For details see the "Burst Interrupt" - Section of this datasheet.

### Example:

#### Read Burst Timing Example: (CL = 3, AL = 0, RL = 3, BL = 4)

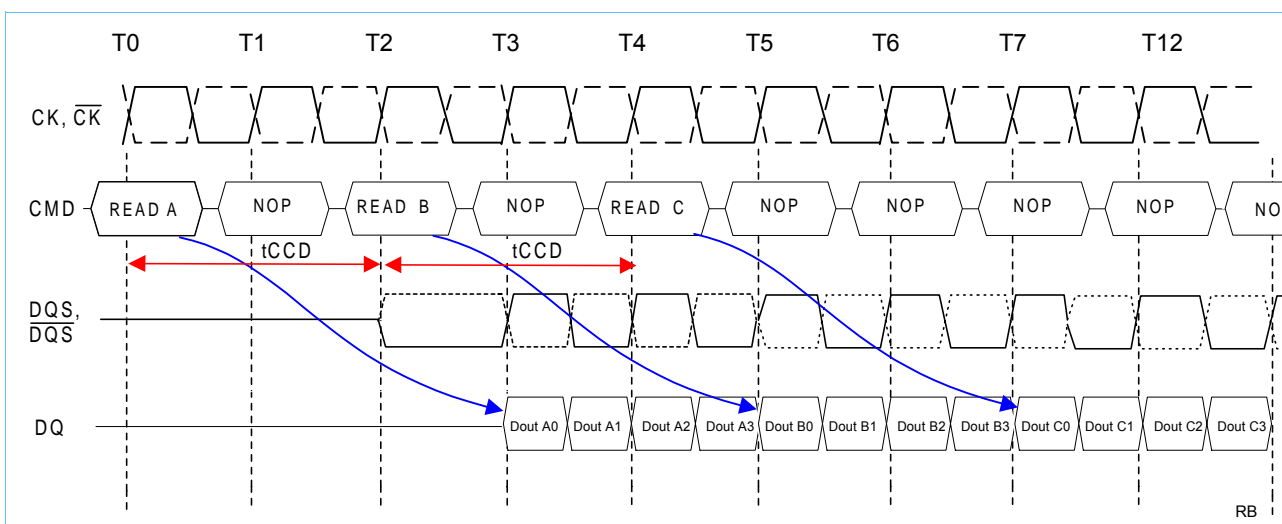

### 2.6.1 Posted $\overline{\text{CAS}}$

Posted  $\overline{\text{CAS}}$  operation is supported to make command and data bus efficient for sustainable bandwidths in DDR2 SDRAM. In this operation, the DDR2 SDRAM allows a Read or Write command to be issued immediately after the  $\overline{\text{RAS}}$  bank activate command (or any time during the  $\overline{\text{RAS}}$  to  $\overline{\text{CAS}}$  delay time,  $t_{\text{RCD}}$ , period). The command is held for the time of the Additive Latency (AL) before it is issued inside the device. The Read Latency (RL) is the sum of AL and the  $\overline{\text{CAS}}$  latency (CL). Therefore if a user chooses to issue a Read/Write command before the  $t_{\text{RCDmin}}$ , then AL greater than 0 must be written into the EMRS(1). The Write Latency (WL) is always defined as  $\text{RL} - 1$  (Read Latency - 1) where Read Latency is defined as the sum of Additive Latency plus  $\overline{\text{CAS}}$  latency ( $\text{RL} = \text{AL} + \text{CL}$ ). If a user chooses to issue a Read command after the  $t_{\text{RCDmin}}$  period, the Read Latency is also defined as  $\text{RL} = \text{AL} + \text{CL}$ .

#### Examples:

**Read followed by a write to the same bank, Activate to Read delay <  $t_{\text{RCDmin}}$ :**

**AL = 2 and CL = 3, RL = (AL + CL) = 5, WL = (RL - 1) = 4, BL = 4**

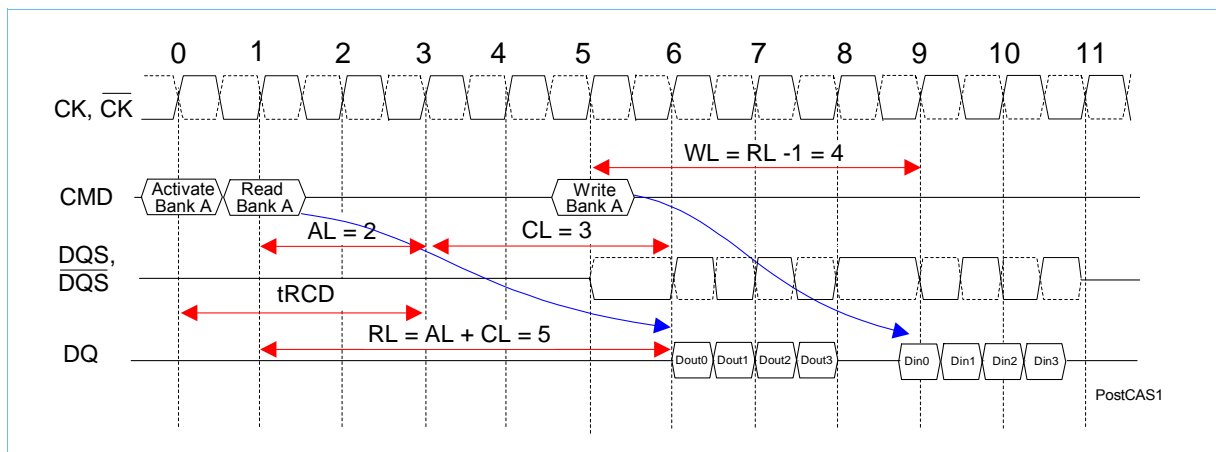

**Read followed by a write to the same bank, Activate to Read delay <  $t_{\text{RCDmin}}$ :**

**AL = 2 and CL = 3, RL = (AL + CL) = 5, WL = (RL - 1) = 4, BL = 8**

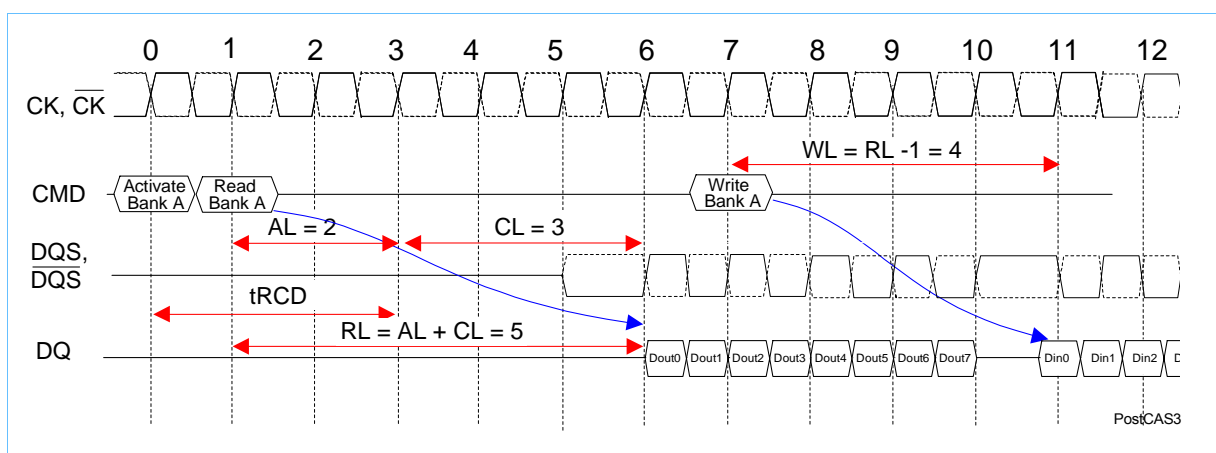

**Read followed by a write to the same bank, Activate to Read delay =  $t_{RCDmin}$ :**  
 $AL = 0, CL = 3, RL = (AL + CL) = 3, WL = (RL - 1) = 2, BL = 4$

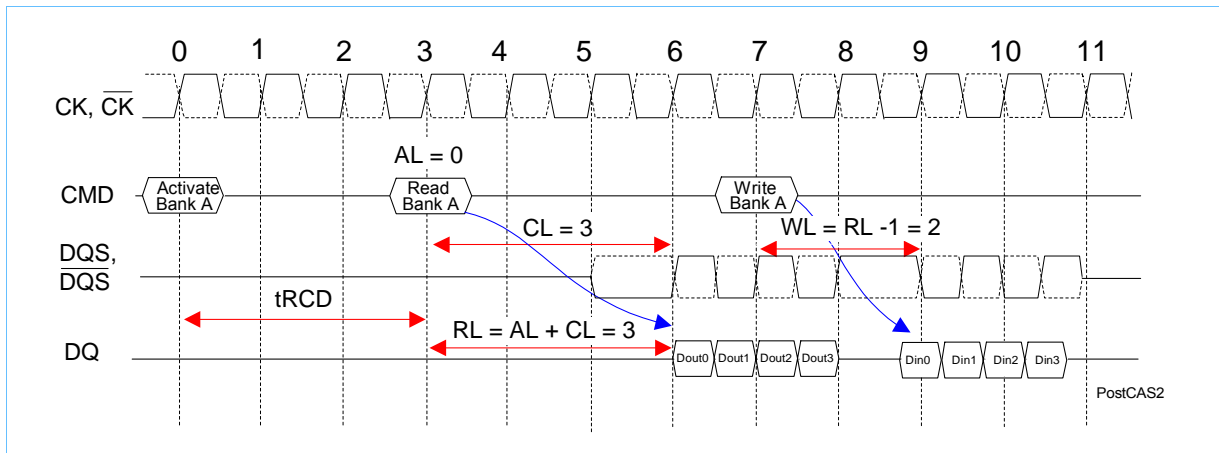

**Read followed by a write to the same bank, Activate to Read delay >  $t_{RCDmin}$ :**  
 $AL = 1, CL = 3, RL = 4, WL = 3, BL = 4$

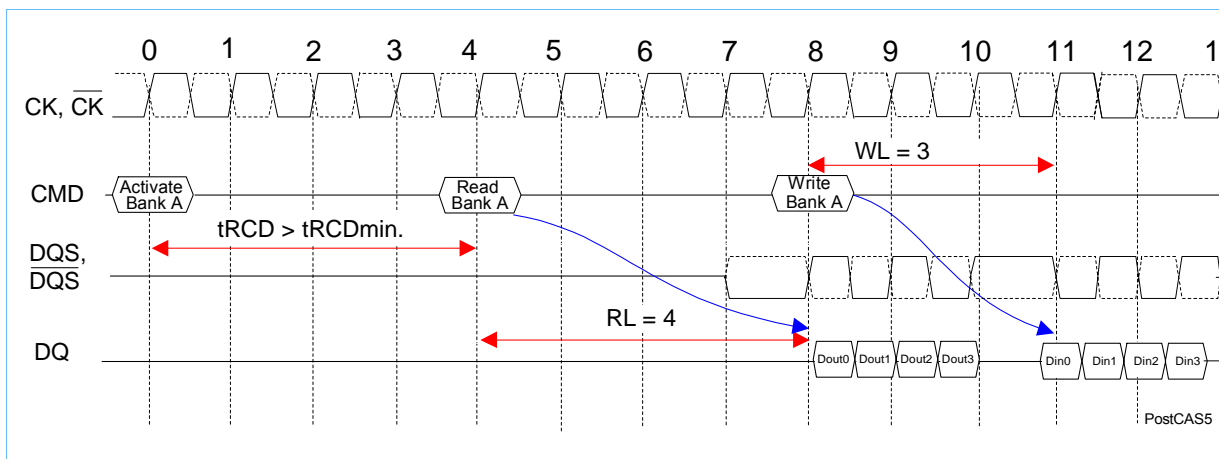

### 2.6.2 Burst Mode Operation

Burst mode operation is used to provide a constant flow of data to memory locations (write cycle), or from memory locations (read cycle). The parameters that define how the burst mode will operate are burst sequence and burst length. The DDR2 SDRAM supports 4 bit and 8 bit burst modes only. For 8 bit burst mode, full interleave address ordering is supported, however, sequential address ordering is nibble based for ease of implementation. The burst length is programmable and defined by the addresses A0 ~ A2 of the MRS. The burst type, either sequential or interleaved, is programmable and defined by the address bit 3 (A3) of the MRS. Seamless burst read or write operations are supported. Interruption of a burst read or write operation is prohibited, when burst length = 4 is programmed. For burst interruption of a read or write burst when burst length = 8 is used, see the “Burst Interruption” section of this datasheet. A Burst Stop command is not supported on DDR2 SDRAM devices.

#### Burst Length and Sequence

Burst Length	Starting Address (A2 A1 A0)	Sequential Addressing (decimal)	Interleave Addressing (decimal)
4	x 0 0	0, 1, 2, 3	0, 1, 2, 3
	x 0 1	1, 2, 3, 0	1, 0, 3, 2
	x 1 0	2, 3, 0, 1	2, 3, 0, 1
	x 1 1	3, 0, 1, 2	3, 2, 1, 0
8	0 0 0	0, 1, 2, 3, 4, 5, 6, 7	0, 1, 2, 3, 4, 5, 6, 7
	0 0 1	1, 2, 3, 0, 5, 6, 7, 4	1, 0, 3, 2, 5, 4, 7, 6
	0 1 0	2, 3, 0, 1, 6, 7, 4, 5	2, 3, 0, 1, 6, 7, 4, 5
	0 1 1	3, 0, 1, 2, 7, 4, 5, 6	3, 2, 1, 0, 7, 6, 5, 4
	1 0 0	4, 5, 6, 7, 0, 1, 2, 3	4, 5, 6, 7, 0, 1, 2, 3
	1 0 1	5, 6, 7, 4, 1, 2, 3, 0	5, 4, 7, 6, 1, 0, 3, 2
	1 1 0	6, 7, 4, 5, 2, 3, 0, 1	6, 7, 4, 5, 2, 3, 0, 1
	1 1 1	7, 4, 5, 6, 3, 0, 1, 2	7, 6, 5, 4, 3, 2, 1, 0

Notes: 1) Page size for all 256Mbit components is 1 kByte  
 2) Order of burst access for sequential addressing is “nibble-based” and therefore different from SDR or DDR components



### 2.6.3 Burst Read Command

The Burst Read command is initiated by having  $\overline{CS}$  and  $\overline{CAS}$  low while holding  $\overline{RAS}$  and  $\overline{WE}$  high at the rising edge of the clock. The address inputs determine the starting column address for the burst. The delay from the start of the command until the data from the first cell appears on the outputs is equal to the value of the read latency (RL). The data strobe output (DQS) is driven low one clock cycle before valid data (DQ) is driven onto the data bus. The first bit of the burst is synchronized with the rising edge of the data strobe (DQS). Each subsequent data-out appears on the DQ pin in phase with the DQS signal in a source synchronous manner. The RL is equal to an additive latency (AL) plus  $\overline{CAS}$  latency (CL). The CL is defined by the Mode Register Set (MRS). The AL is defined by the Extended Mode Register Set (EMRS(1)).

#### Basic Burst Read Timing

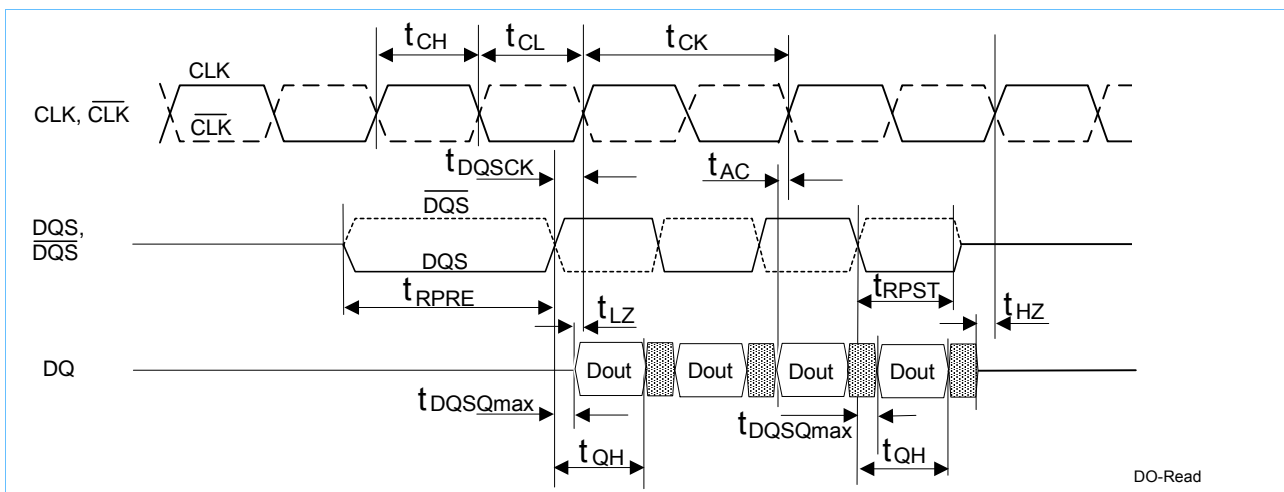

#### Examples:

##### Burst Read Operation: RL = 5 (AL = 2, CL = 3, BL = 4)

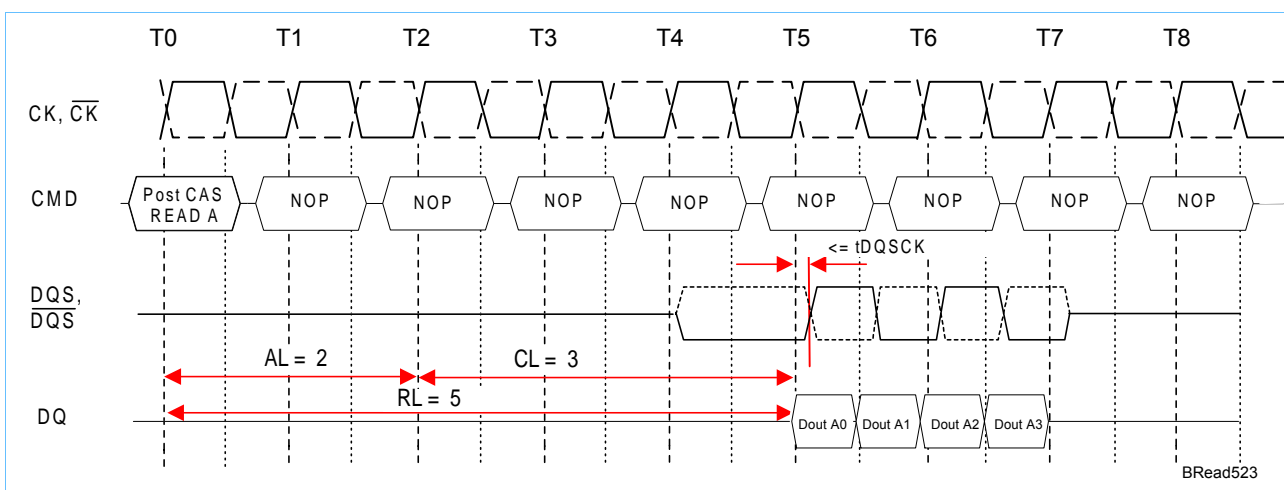

**Burst Read Operation: RL = 3 (AL = 0, CL = 3, BL = 8)**

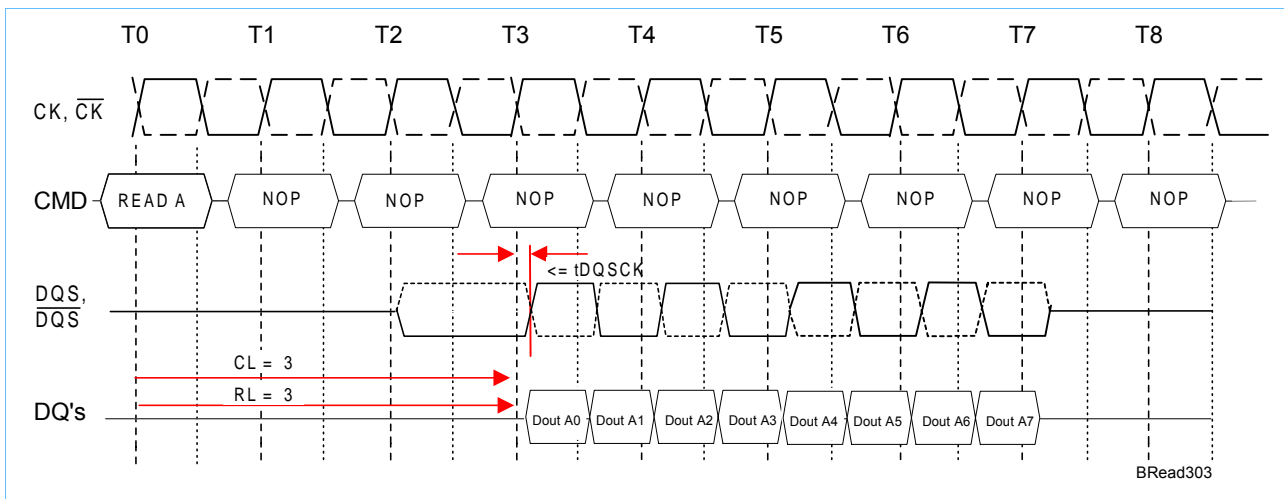

**Burst Read followed by Burst Write: RL = 5, WL = (RL-1) = 4, BL = 4**

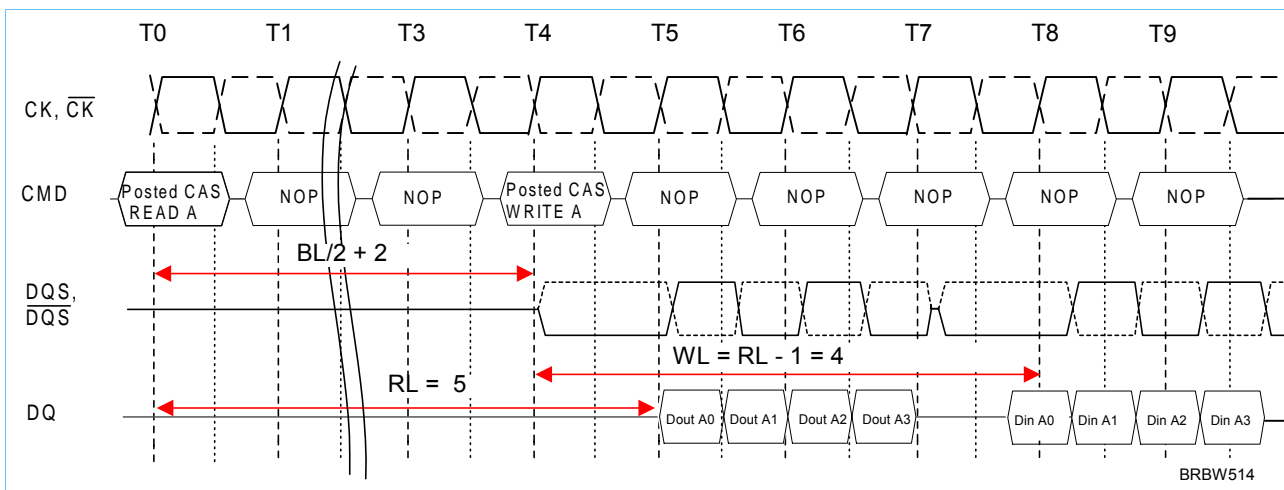

The minimum time from the burst read command to the burst write command is defined by a read-to-write turn-around time, which is  $BL/2 + 2$  clocks.

**Seamless Burst Read Operation: RL = 5, AL = 2, CL = 3, BL = 4**

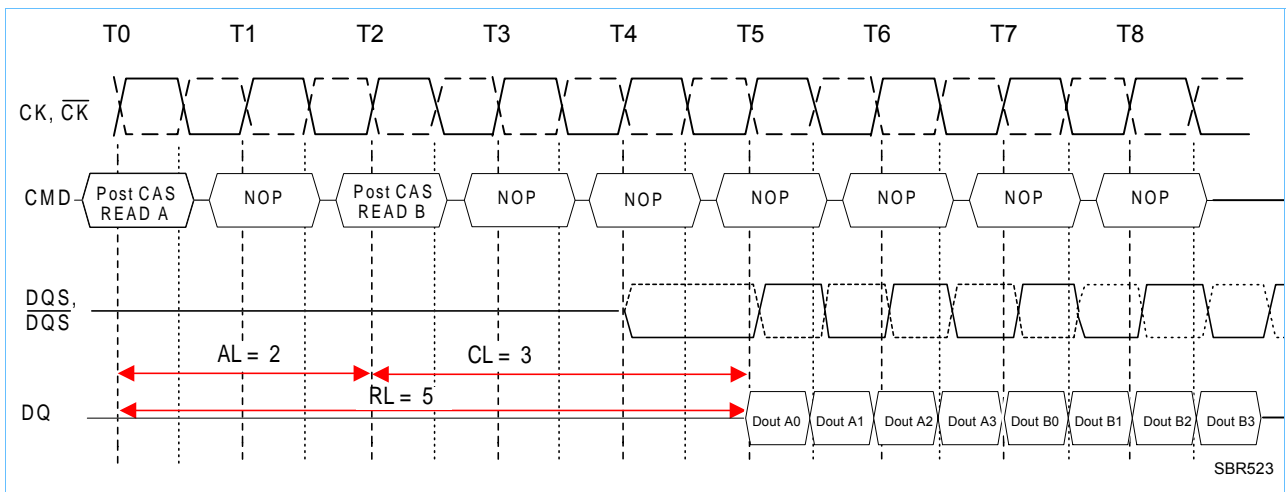

The seamless burst read operation is supported by enabling a read command at every BL / 2 number of clocks. This operation is allowed regardless of same or different banks as long as the banks are activated.

**Seamless Burst Read Operation: RL = 3, AL = 0, CL = 3, BL = 8 (non interrupting)**

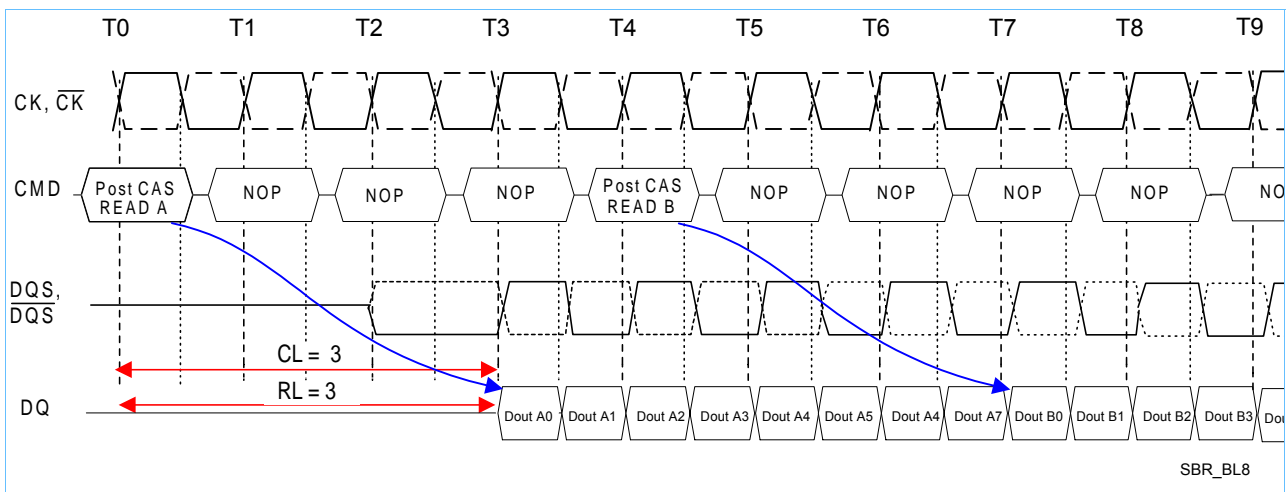

The seamless, non interrupting 8-bit burst read operation is supported by enabling a read command at every BL / 2 number of clocks. This operation is allowed regardless of same or different banks as long as the banks are activated.

### 2.6.4 Burst Write Command

The Burst Write command is initiated by having  $\overline{CS}$ ,  $\overline{CAS}$  and  $\overline{WE}$  low while holding  $\overline{RAS}$  high at the rising edge of the clock. The address inputs determine the starting column address. Write latency (WL) is defined by a read latency (RL) minus one and is equal to  $(AL + CL - 1)$ . A data strobe signal (DQS) has to be driven low (preamble) a time  $t_{WPRE}$  prior to the WL. The first data bit of the burst cycle must be applied to the DQ pins at the first rising edge of the DQS following the preamble. The  $t_{DQSS}$  specification must be satisfied for write cycles. The subsequent burst bit data are issued on successive edges of the DQS until the burst length is completed. When the burst has finished, any additional data supplied to the DQ pins will be ignored. The DQ signal is ignored after the burst write operation is complete. The time from the completion of the burst write to bank precharge is named "write recovery time" ( $t_{WR}$ ) and is the time needed to store the write data into the memory array.  $t_{WR}$  is an analog timing parameter (see the AC table in this specification) and is not the programmed value for WR in the MRS.

#### Basic Burst Write Timing

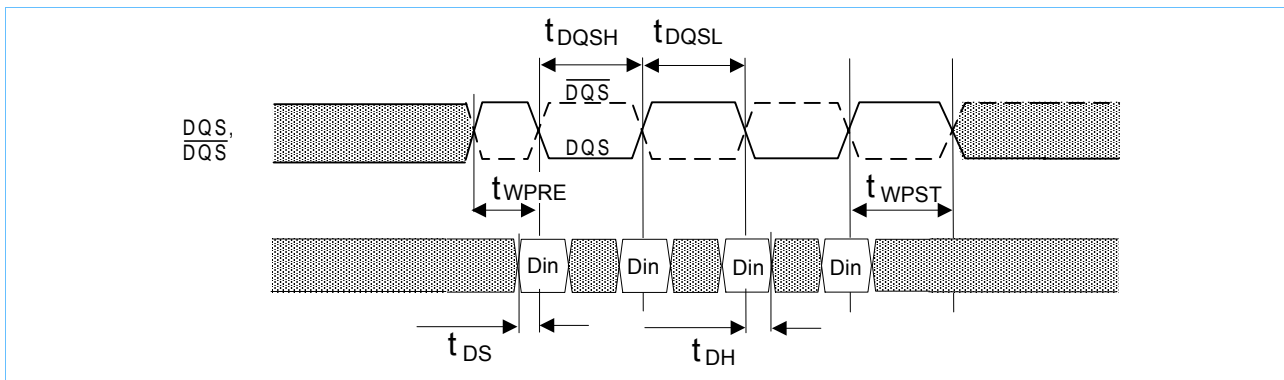

**Example:**

**Burst Write Operation: RL = 5 (AL = 2, CL = 3), WL = 4, BL = 4**

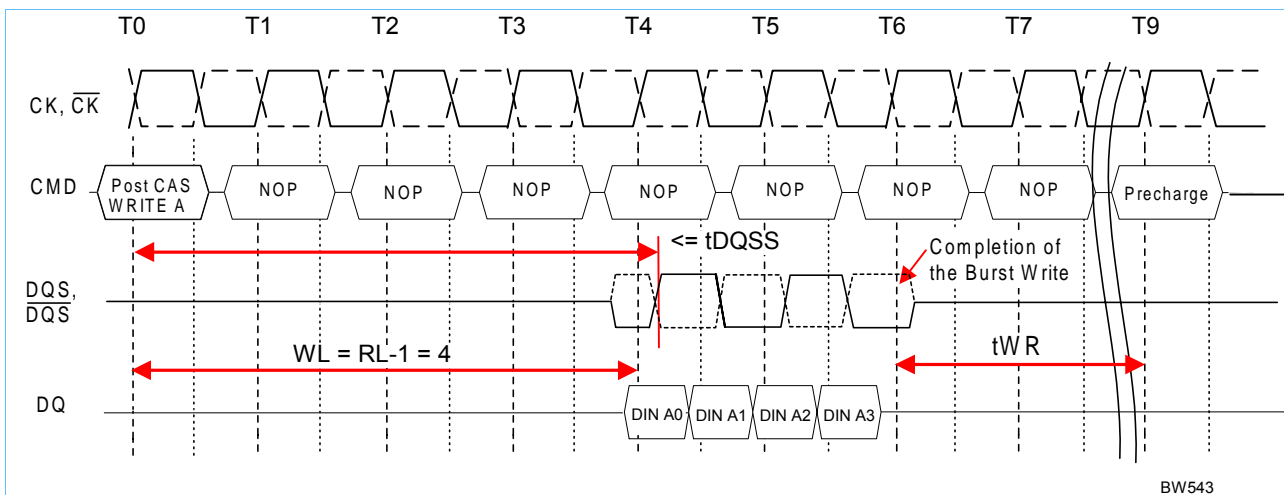

BW543

**Burst Write Operation: RL = 3 (AL = 0, CL = 3), WL = 2, BL = 4**

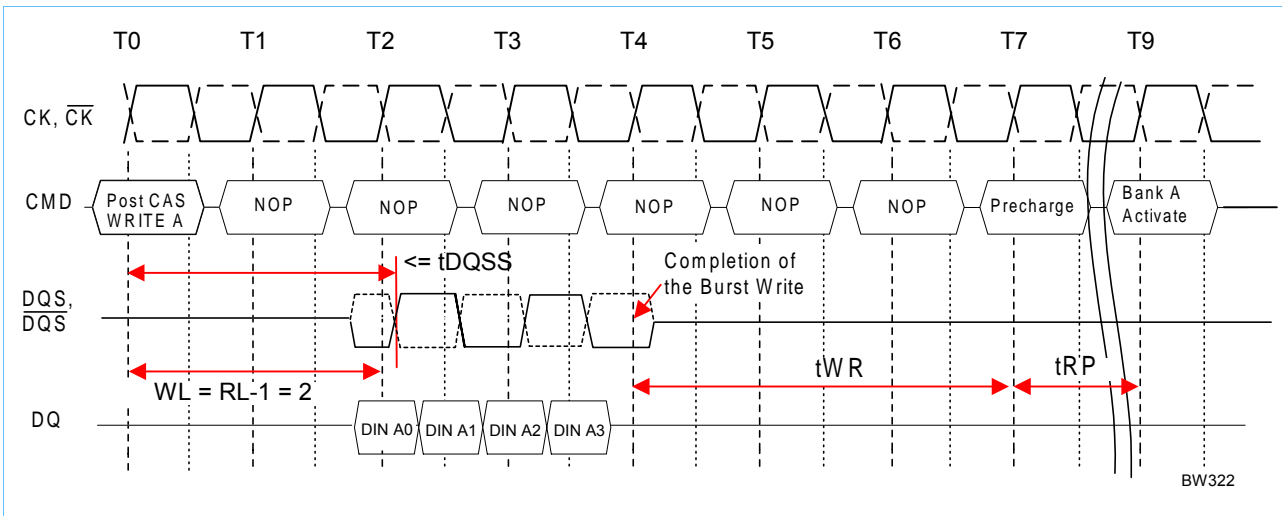

**Burst Write followed by Burst Read: RL = 5 (AL = 2, CL = 3), WL = 4, twttr = 2, BL = 4**

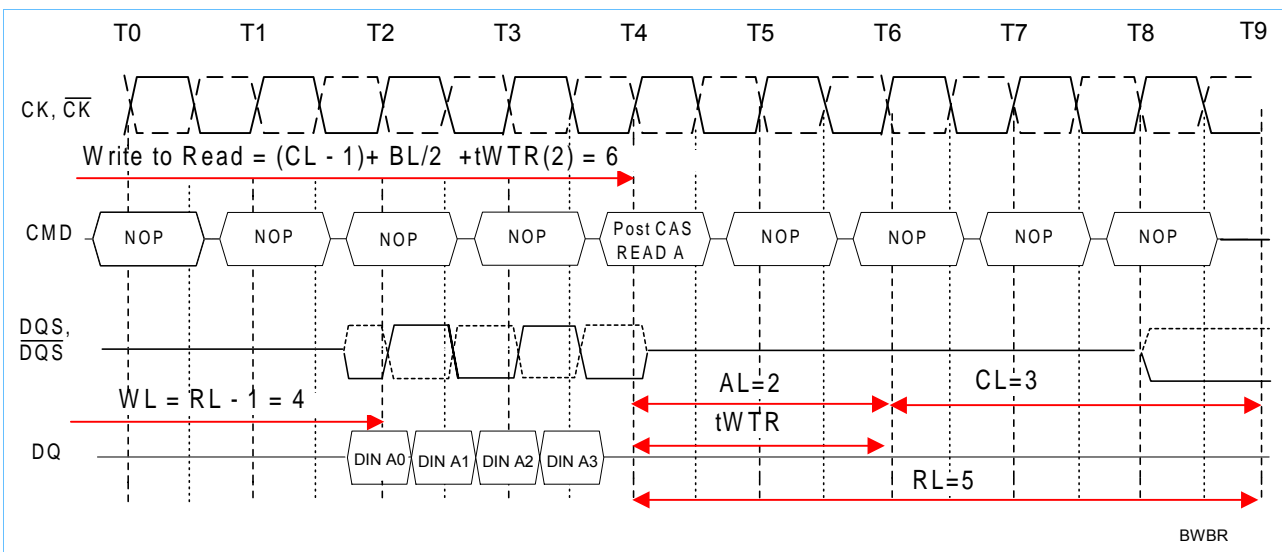

The minimum number of clocks from the burst write command to the burst read command is

$$(CL - 1) + BL/2 + t_{WTR}$$

where  $t_{WTR}$  is the write-to-read turn-around time  $t_{WTR}$  expressed in clock cycles. The  $t_{WTR}$  is not a write recovery time ( $t_{WR}$ ) but the time required to transfer 4 bit write data from the input buffer into sense amplifiers in the array.

**Seamless Burst Write Operation: RL = 5, WL = 4, BL = 4**

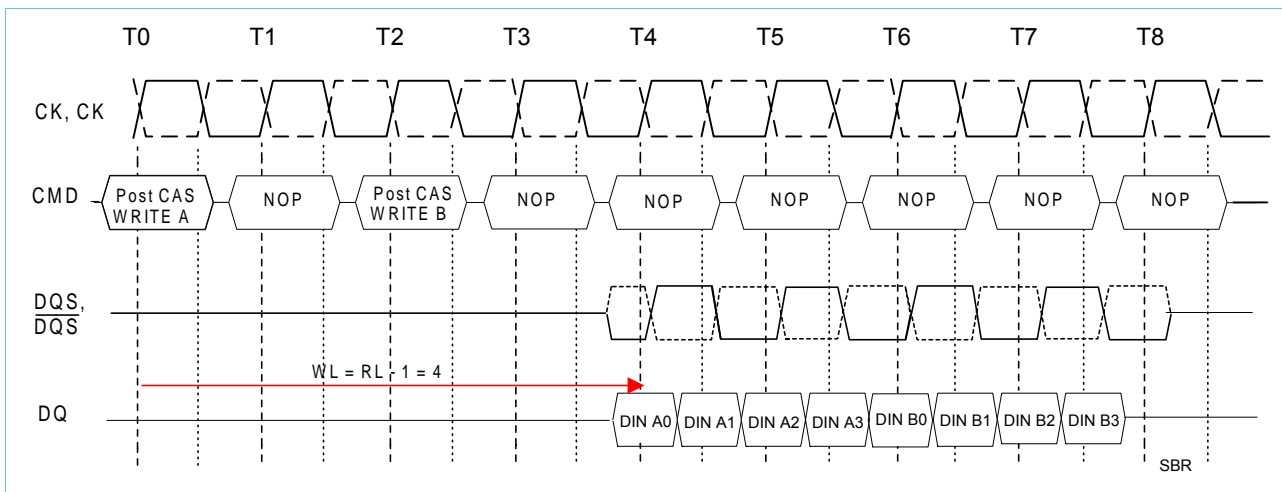

The seamless burst write operation is supported by enabling a write command every  $BL / 2$  number of clocks. This operation is allowed regardless of same or different banks as long as the banks are activated.

**Seamless Burst Write Operation: RL = 3, WL = 2, BL = 8, non interrupting**

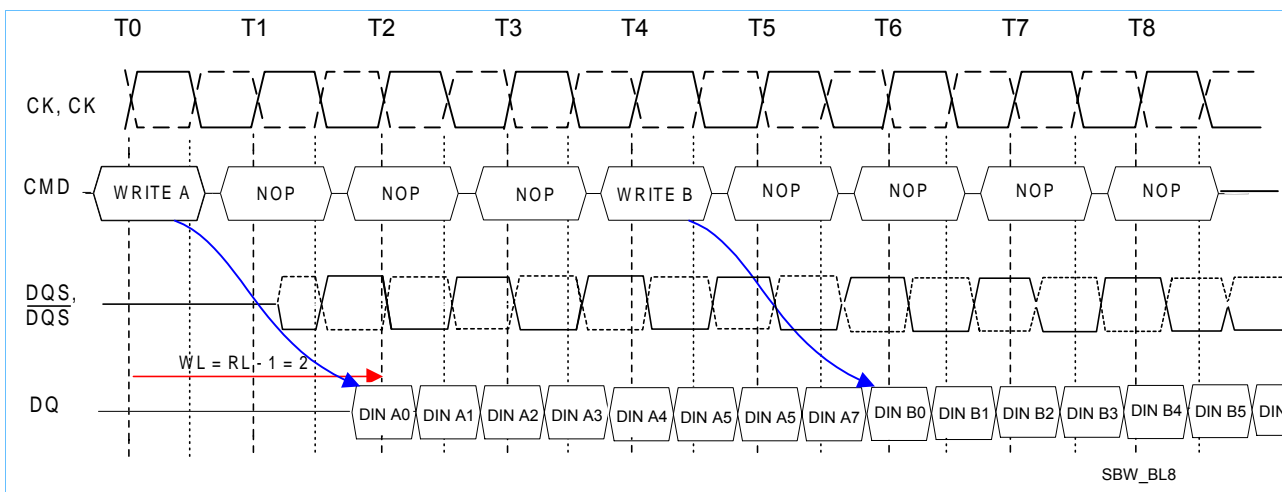

The seamless, non interrupting 8-bit burst write operation is supported by enabling a write command at every  $BL / 2$  number of clocks. This operation is allowed regardless of same or different banks as long as the banks are activated.

### 2.6.5 Write Data Mask

One write data mask input (DM) for x4 and x8 components and two write data mask inputs (LDM, UDM) for x16 components are supported on DDR2 SDRAM's, consistent with the implementation on DDR SDRAM's. It has identical timings on write operations as the data bits, and though used in a uni-directional manner, is internally loaded identically to data bits to insure matched system timing. Data mask is not used during read cycles. If DM is high during a write burst coincident with the write data, the write data bit is not written to the memory. For x8 components the DM function is disabled, when RDQS /  $\overline{\text{RDQS}}$  are enabled by EMRS(1).

#### Write Data Mask Timing

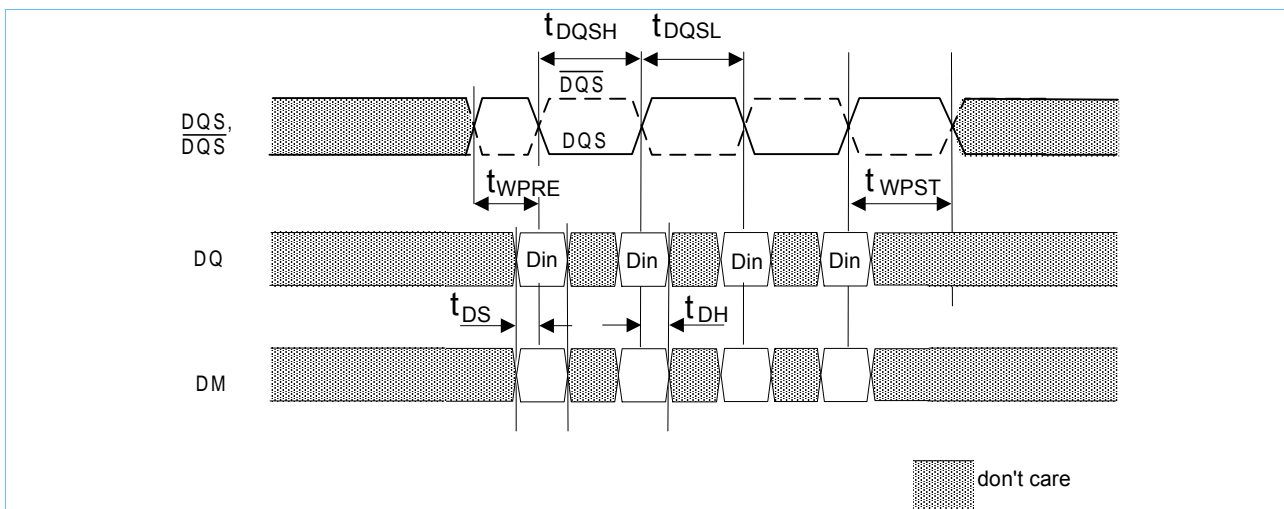

#### Burst Write Operation with Data Mask: RL = 3 (AL = 0, CL = 3), WL = 2, tWR = 3, BL = 4

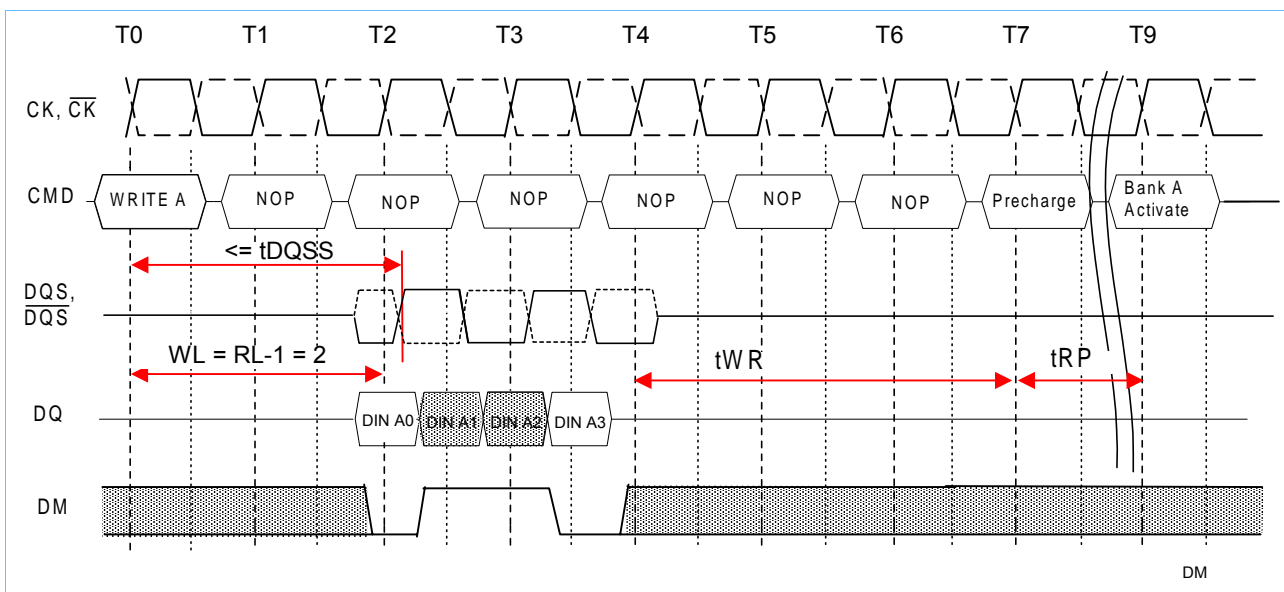

### 2.6.6 Burst Interruption

Interruption of a read or write burst is prohibited for burst length of 4 and only allowed for burst length of 8 under the following conditions:

1. A Read Burst of 8 can only be interrupted by another Read command. Read burst interruption by a Write or Precharge Command is prohibited.
2. A Write Burst of 8 can only be interrupted by another Write command. Write burst interruption by a Read or Precharge Command is prohibited.
3. Read burst interrupt must occur exactly two clocks after the previous Read command. Any other Read burst interrupt timings are prohibited.
4. Write burst interrupt must occur exactly two clocks after the previous Write command. Any other Read burst interrupt timings are prohibited.
5. Read or Write burst interruption is allowed to any bank inside the DDR2 SDRAM.
6. Read or Write burst with Auto-Precharge enabled is not allowed to be interrupted.
7. Read burst interruption is allowed by a Read with Auto-Precharge command.
8. Write burst interruption is allowed by a Write with Auto-Precharge command.
9. All command timings are referenced to burst length set in the mode register. They are not referenced to the actual burst. For example, Minimum Read to Precharge timing is  $AL + BL/2$  where BL is the burst length set in the mode register and not the actual burst (which is shorter because of interrupt). Minimum Write to Precharge timing is  $WL + BL/2 + tWR$ , where  $tWR$  starts with the rising clock after the un-interrupted burst end and not from the end of the actual burst end.

#### Examples:

#### Read Burst Interrupt Timing Example: (CL = 3, AL = 0, RL = 3, BL = 8)

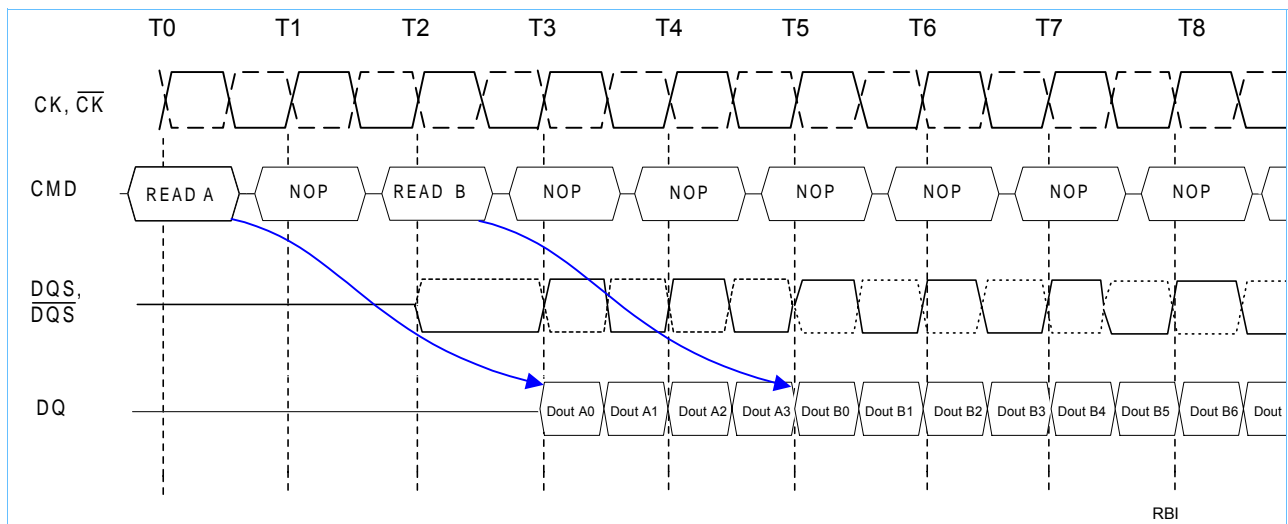



**Write Burst Interrupt Timing Example: (CL = 3, AL = 0, WL = 2, BL = 8)**

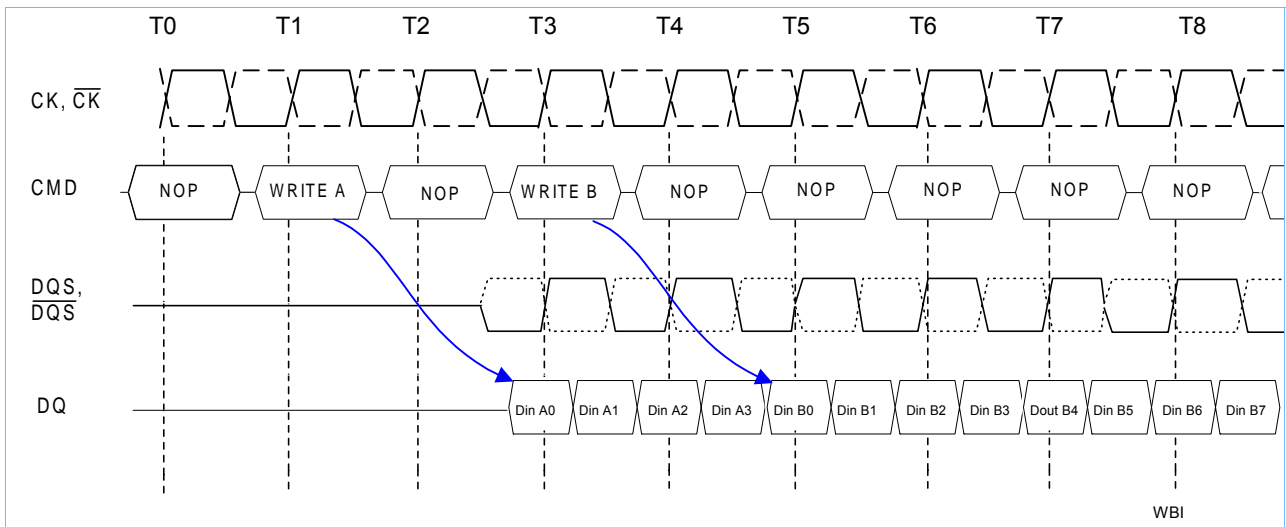

## 2.7 Precharge Command

The Precharge Command is used to precharge or close a bank that has been activated. The Precharge Command is triggered when  $\overline{CS}$ ,  $\overline{RAS}$  and  $\overline{WE}$  are low and  $\overline{CAS}$  is high at the rising edge of the clock. The Precharge Command can be used to precharge each bank independently or all banks simultaneously. Three address bits A10, BA0 and BA1 are used to define which bank to precharge when the command is issued.

### Bank Selection for Precharge by Address Bits

A10	BA0	BA1	Precharge Bank(s)
LOW	LOW	LOW	Bank 0 only
LOW	LOW	HIGH	Bank 1 only
LOW	HIGH	LOW	Bank 2 only
LOW	HIGH	HIGH	Bank 3 only
HIGH	Don't Care	Don't Care	all banks

Note: The bank address assignment is the same for activating and precharging a specific bank.

### 2.7.1 Burst Read Operation Followed by a Precharge

The following rules apply as long as the tRTP timing parameter - Internal Read to Precharge Command delay time - is less or equal two clocks, which is the case for operating frequencies less or equal 266 Mhz (DDR2 400 and 533 speed sorts):

Minimum Read to Precharge command spacing to the same bank = AL + BL/2 clocks. For the earliest possible precharge, the Precharge command may be issued on the rising edge which is "Additive Latency (AL) + BL/2 clocks" after a Read Command, as long as the minimum tRAS timing is satisfied.

A new bank active command may be issued to the same bank if the following two conditions are satisfied simultaneously:

- (1) The RAS precharge time (tRP) has been satisfied from the clock at which the precharge begins.
- (2) The RAS cycle time (tRCmin) from the previous bank activation has been satisfied.

For operating frequencies higher than 266 MHz, tRTP becomes > 2 clocks and one additional clock cycle has to be added for the minimum Read to Precharge command spacing, which now becomes AL + BL/2 + 1 clocks.

**Examples:**

**Burst Read Operation Followed by Precharge: RL = 4 (AL = 1, CL = 3), BL = 4, tRTP <= 2 clocks**

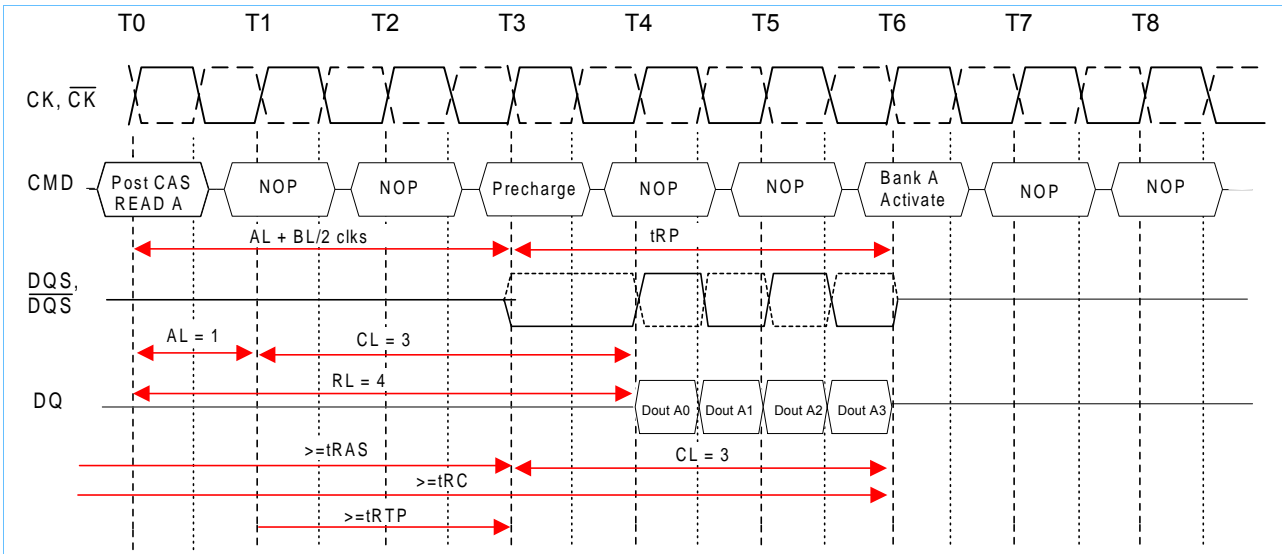

**Burst Read Operation Followed by Precharge: RL = 4 (AL = 1, CL = 3), BL = 8, tRTP <= 2 clocks**

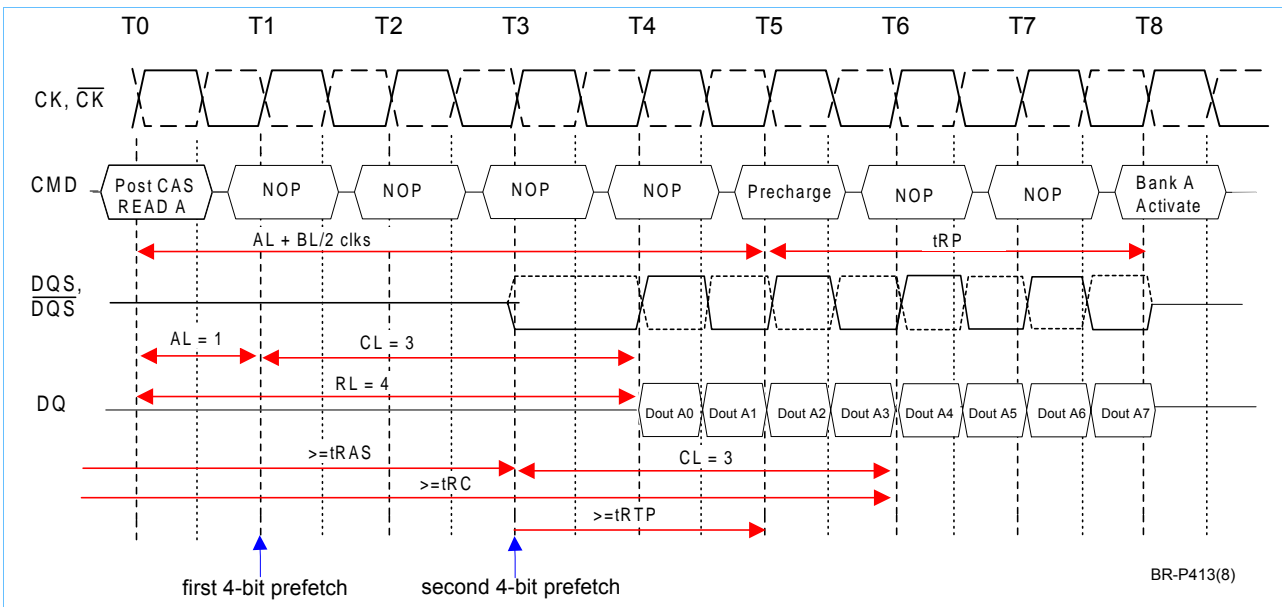

BR-P413(8)

**Burst Read Operation Followed by Precharge: RL = 5 (AL = 2, CL = 3), BL = 4, tRTP ≤ 2 clocks**

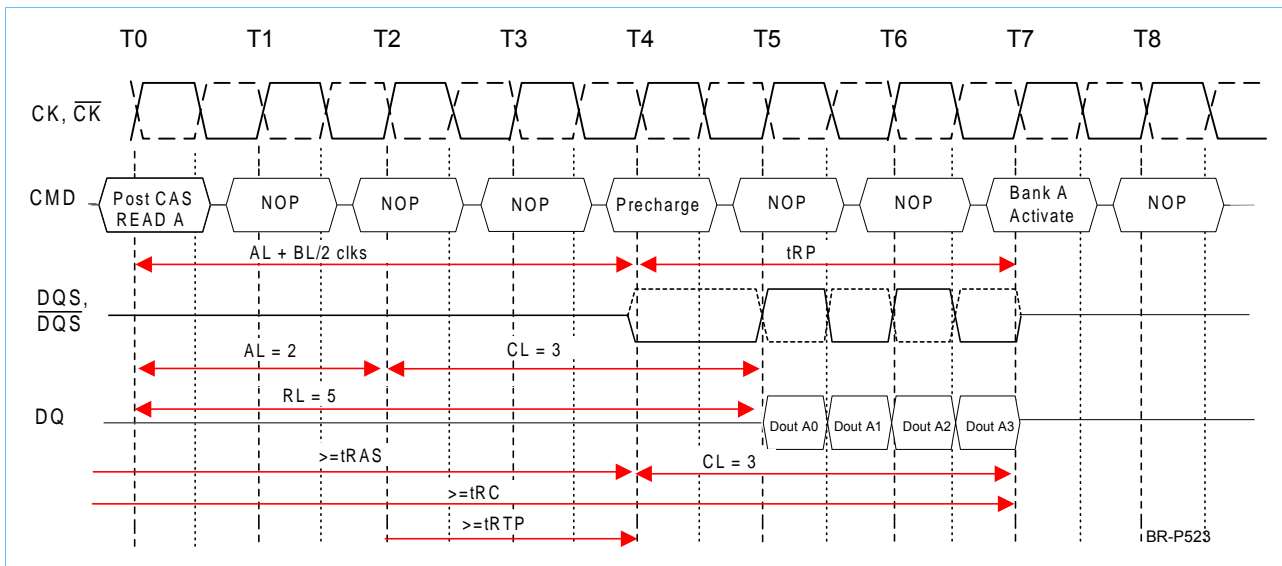

**Burst Read Operation Followed by Precharge: RL = 6, (AL = 2, CL = 4), BL = 4, tRTP ≤ 2 clocks**

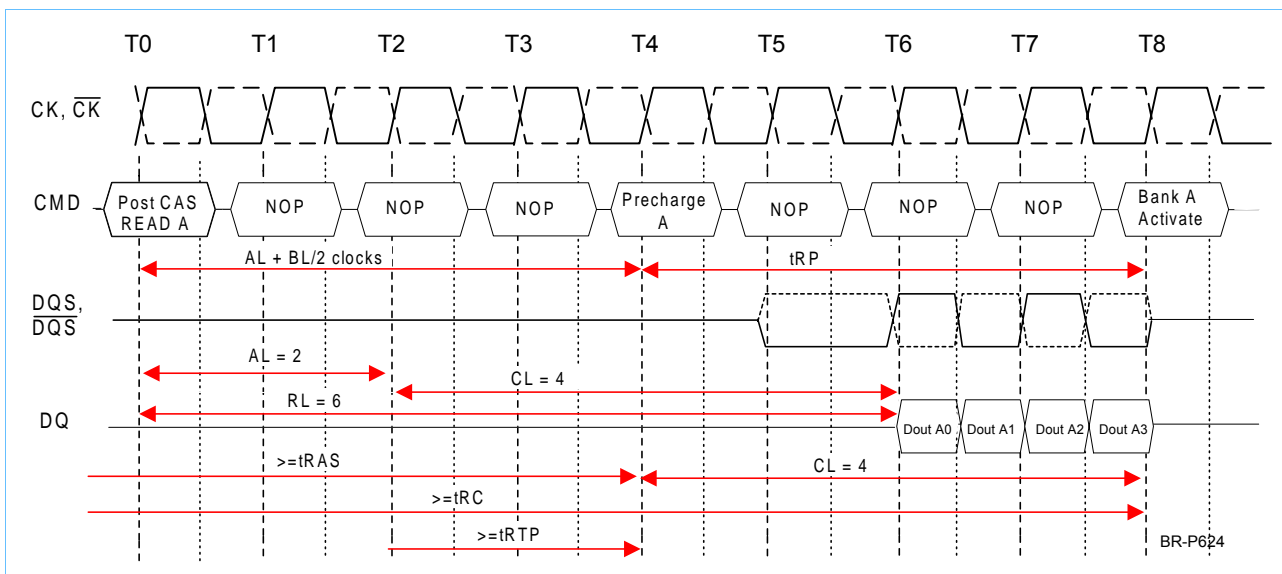

**Burst Read Operation Followed by Precharge: RL = 4, (AL = 0, CL = 4), BL = 8, tRTP > 2 clocks**

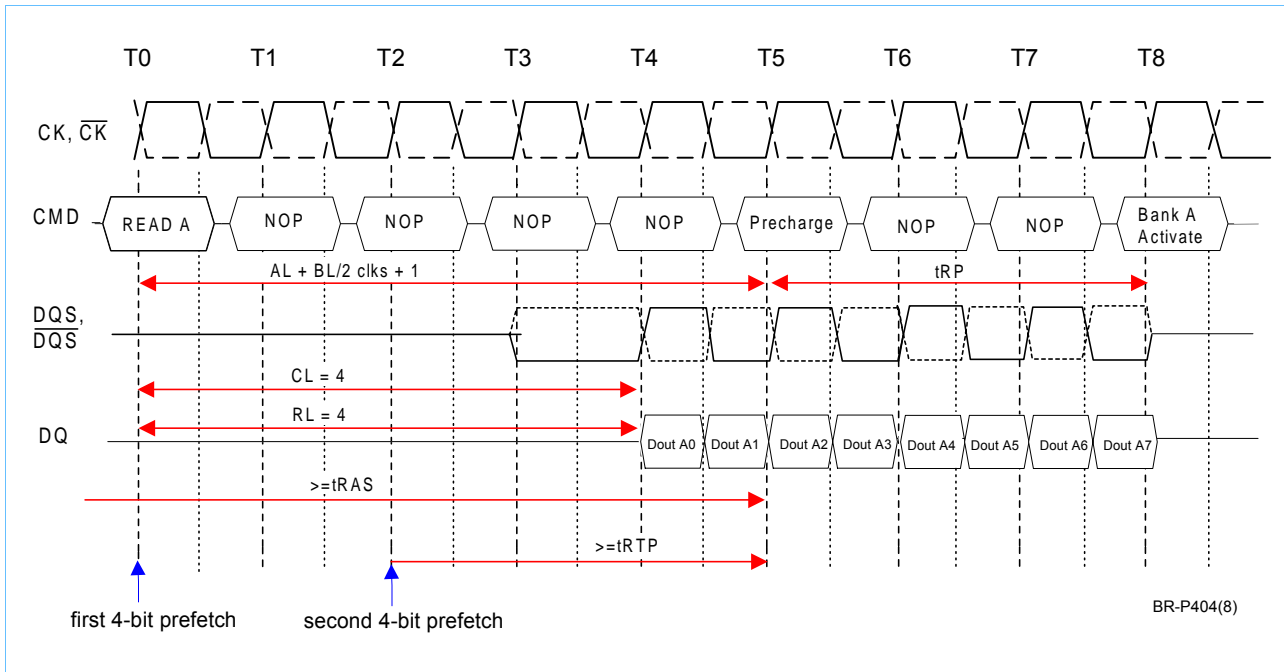

### 2.7.2 Burst Write followed by Precharge

Minimum Write to Precharge command spacing to the same bank =  $WL + BL/2 + tWR$ . For write cycles, a delay must be satisfied from the completion of the last burst write cycle until the Precharge command can be issued. This delay is known as a write recovery time ( $tWR$ ) referenced from the completion of the burst write to the Precharge command. No Precharge command should be issued prior to the  $tWR$  delay, as DDR2 SDRAM does not support any burst interrupt by a Precharge command.  $tWR$  is an analog timing parameter (see the AC table in this datasheet) and is not the programmed value for  $tWR$  in the MRS.

#### Examples:

**Burst Write followed by Precharge:  $WL = (RL - 1) = 3, BL = 4, tWR = 3$**

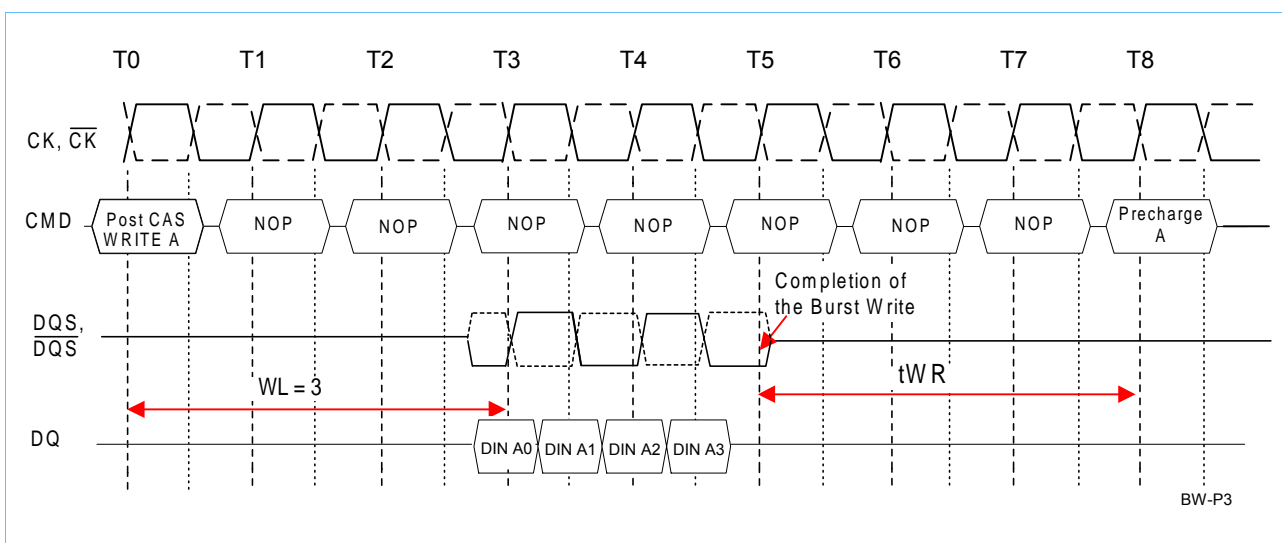

**Burst Write followed by Precharge:  $WL = (RL - 1) = 4, BL = 4, tWR = 3$**

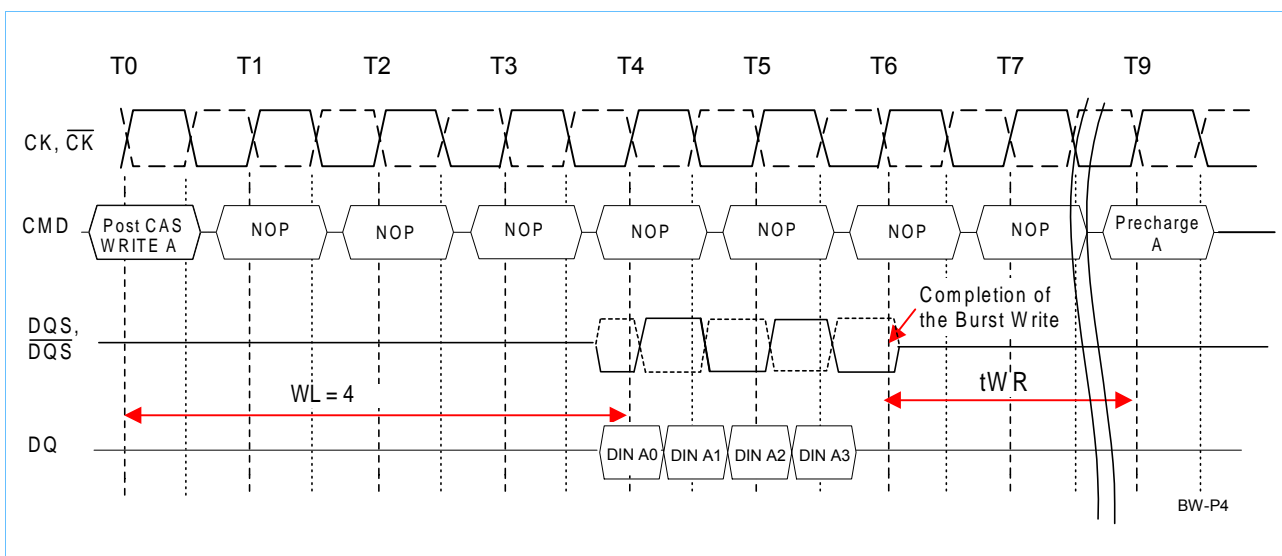

## 2.8 Auto-Precharge Operation

Before a new row in an active bank can be opened, the active bank must be precharged using either the Precharge Command or the Auto-Precharge function. When a Read or a Write Command is given to the DDR2 SDRAM, the  $\overline{\text{CAS}}$  timing accepts one extra address, column address A10, to allow the active bank to automatically begin precharge at the earliest possible moment during the burst read or write cycle. If A10 is low when the Read or Write Command is issued, then normal Read or Write burst operation is executed and the bank remains active at the completion of the burst sequence. If A10 is high when the Read or Write Command is issued, then the Auto-Precharge function is enabled. During Auto-Precharge, a Read Command will execute as normal with the exception that the active bank will begin to precharge internally on the rising edge which is CAS Latency (CL) clock cycles before the end of the read burst. Auto-Precharge is also implemented for Write Commands. The precharge operation engaged by the Auto-Precharge command will not begin until the last data of the write burst sequence is properly stored in the memory array. This feature allows the precharge operation to be partially or completely hidden during burst read cycles (dependent upon CAS Latency) thus improving system performance for random data access. The RAS lockout circuit internally delays the precharge operation until the array restore operation has been completed so that the Auto-Precharge command may be issued with any read or write command.

### 2.8.1 Burst Read with Auto-Precharge

If A10 is high when a Read Command is issued, the Read with Auto-Precharge function is engaged. The DDR2 SDRAM starts an Auto-Precharge operation on the rising edge which is  $(AL + BL/2)$  cycles later from the Read with AP command if  $t_{\text{RASmin}}$  and  $t_{\text{RTP}}$  are satisfied. If  $t_{\text{RASmin}}$  is not satisfied at the edge, the start point of Auto-Precharge operation will be delayed until  $t_{\text{RASmin}}$  is satisfied. If  $t_{\text{RTPmin}}$  is not satisfied at the edge, the start point of Auto-Precharge operation will be delayed until  $t_{\text{RTPmin}}$  is satisfied.

In case the internal precharge is pushed out by  $t_{\text{RTP}}$ ,  $t_{\text{RP}}$  starts at the point where the internal precharge happens (not at the next rising clock edge after this event). So for  $BL = 4$  the minimum time from Read with Auto-Precharge to the next Activate command becomes  $AL + t_{\text{RTP}} + t_{\text{RP}}$ . For  $BL = 8$  the time from Read with Auto-Precharge to the next Activate command is  $AL + 2 + t_{\text{RTP}} + t_{\text{RP}}$ . Note that  $(t_{\text{RTP}} + t_{\text{RP}})$  has to be rounded up to the next integer value. In any event internal precharge does not start earlier than two clocks after the last 4-bit prefetch.

A new bank active (command) may be issued to the same bank if the following two conditions are satisfied simultaneously:

- (1) The  $\overline{\text{RAS}}$  precharge time ( $t_{\text{RP}}$ ) has been satisfied from the clock at which the Auto-Precharge begins.
- (2) The  $\overline{\text{RAS}}$  cycle time ( $t_{\text{RC}}$ ) from the previous bank activation has been satisfied.

**Examples:**

**Burst Read with Auto-Precharge followed by an activation to the Same Bank (tRC Limit)**

**RL = 5 (AL = 2, CL = 3), BL = 4, tRTP <= 2 clocks**

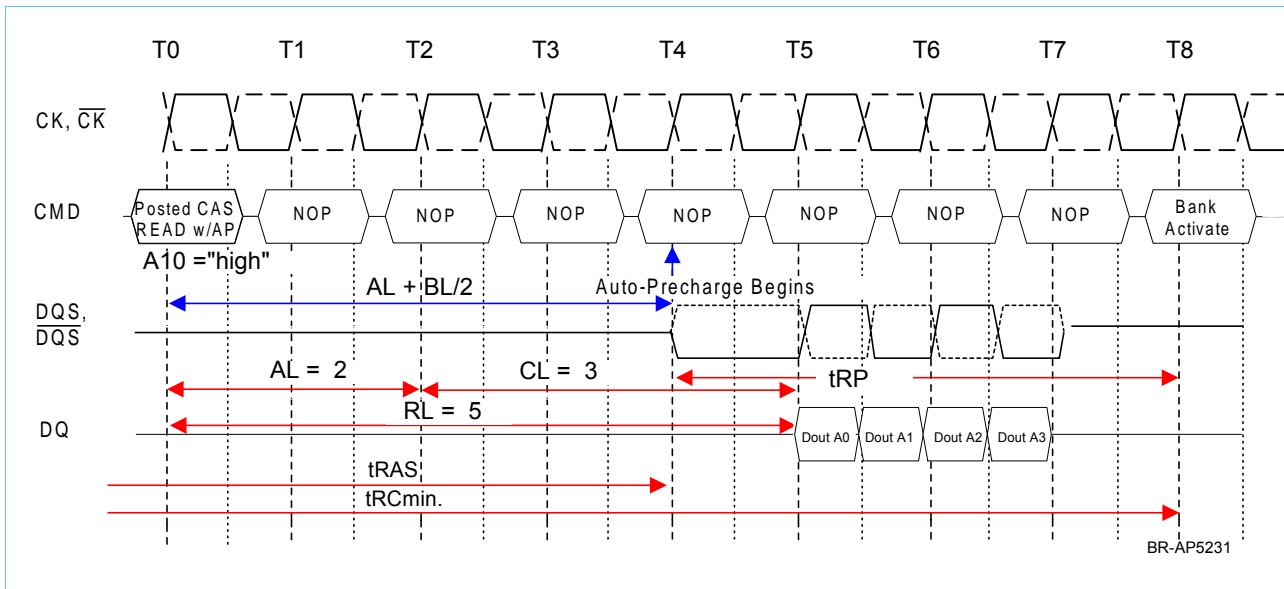

**Burst Read with Auto-Precharge followed by an Activation to the Same Bank (tRAS Limit):**

**RL = 5 (AL = 2, CL = 3), BL = 4, tRTP <= 2 clocks**

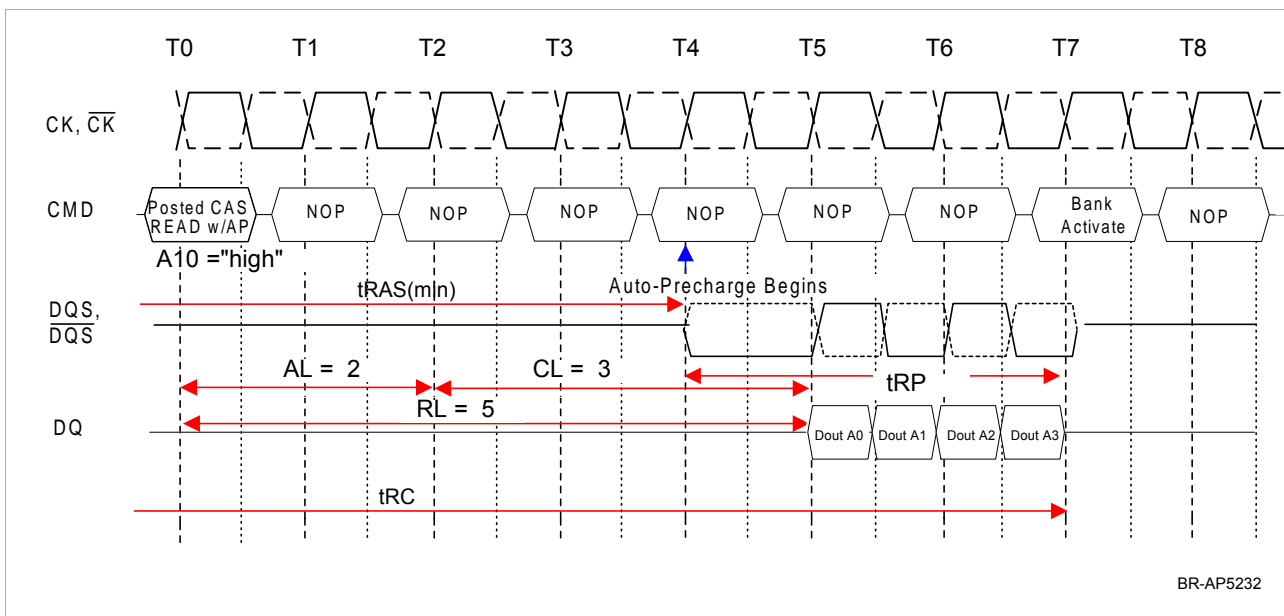



**Burst Read with Auto-Precharge followed by an Activation to the Same Bank:**

**RL = 4 (AL = 1, CL = 3), BL = 8,  $t_{RTP} \leq 2$  clocks**

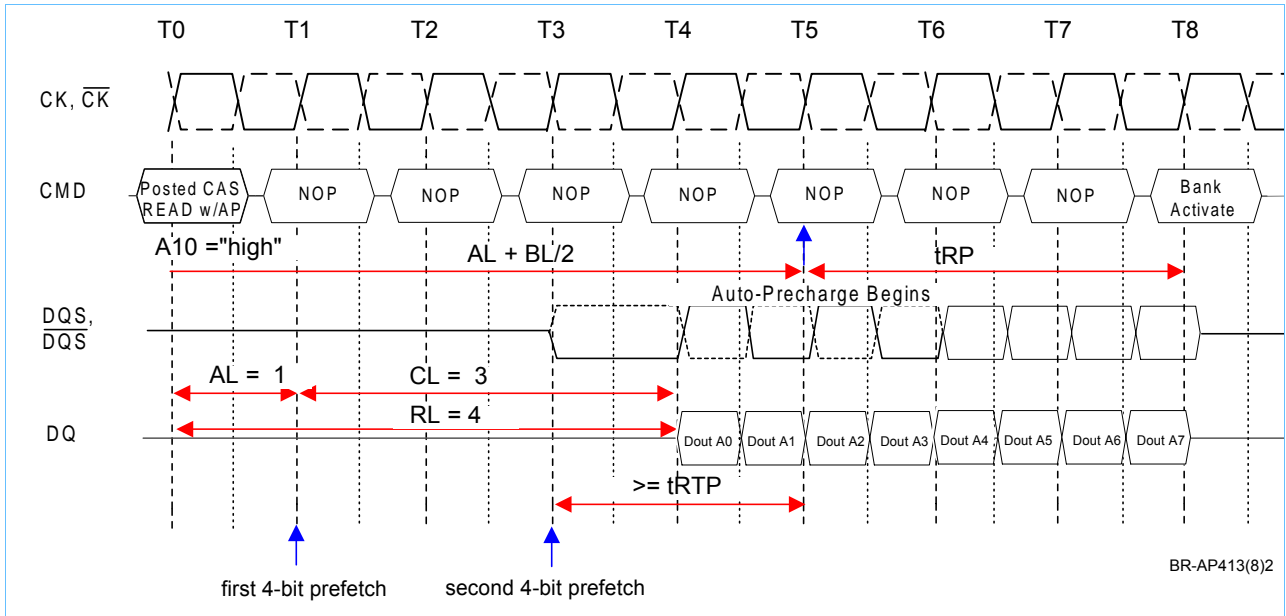

**Burst Read with Auto-Precharge followed by an Activation to the Same Bank:**

**RL = 4 (AL = 1, CL = 3), BL = 4,  $t_{RTP} > 2$  clocks**

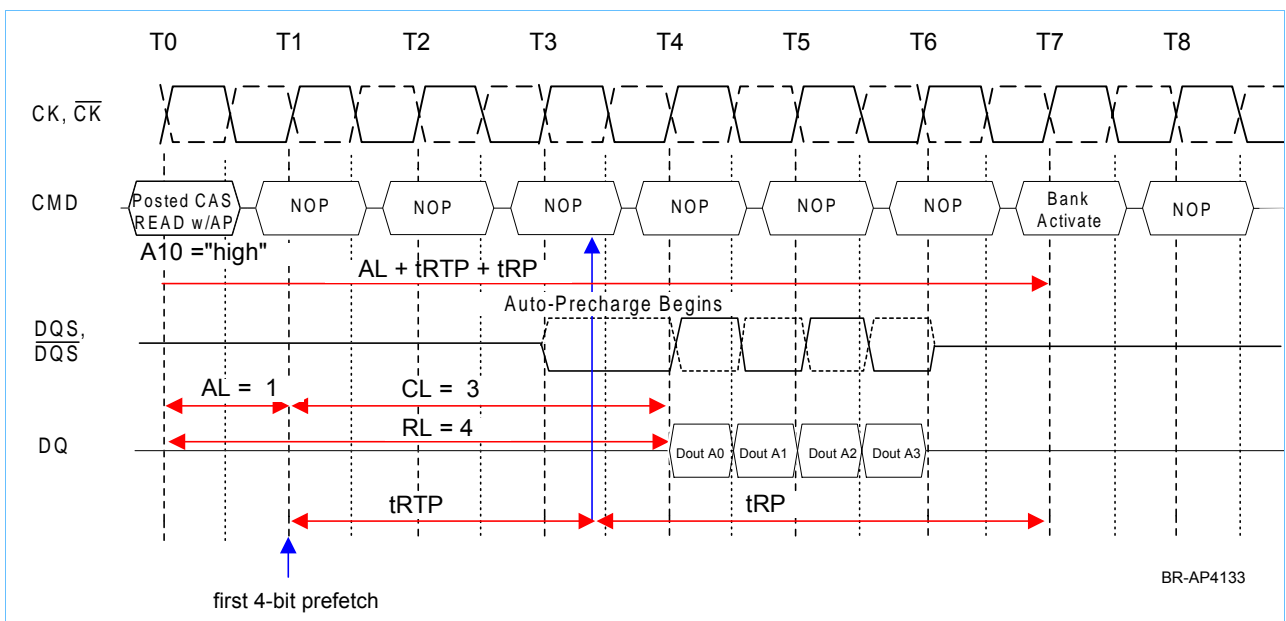

### 2.8.2 Burst Write with Auto-Precharge

If A10 is high when a Write Command is issued, the Write with Auto-Precharge function is engaged. The DDR2 SDRAM automatically begins precharge operation after the completion of the write burst plus the write recovery time delay (WR), programmed in the MRS register, as long as tRAS is satisfied. The bank undergoing Auto-Precharge from the completion of the write burst may be reactivated if the following two conditions are satisfied.

- (1) The last data-in to bank activate delay time ( $t_{DAL} = WR + t_{RP}$ ) has been satisfied.
- (2) The RAS cycle time ( $t_{RC}$ ) from the previous bank activation has been satisfied.

In DDR2 SDRAM's the write recovery time delay (WR) has to be programmed into the MRS mode register. As long as the analog twr timing parameter is not violated, WR can be programmed between 2 and 6 clock cycles. Minimum Write to Activate command spacing to the same bank =  $WL + BL/2 + t_{DAL}$ .

#### Examples:

**Burst Write with Auto-Precharge (tRC Limit):  $WL = 2, t_{DAL} = 6$  ( $WR = 3, t_{RP} = 3$ ),  $BL = 4$**

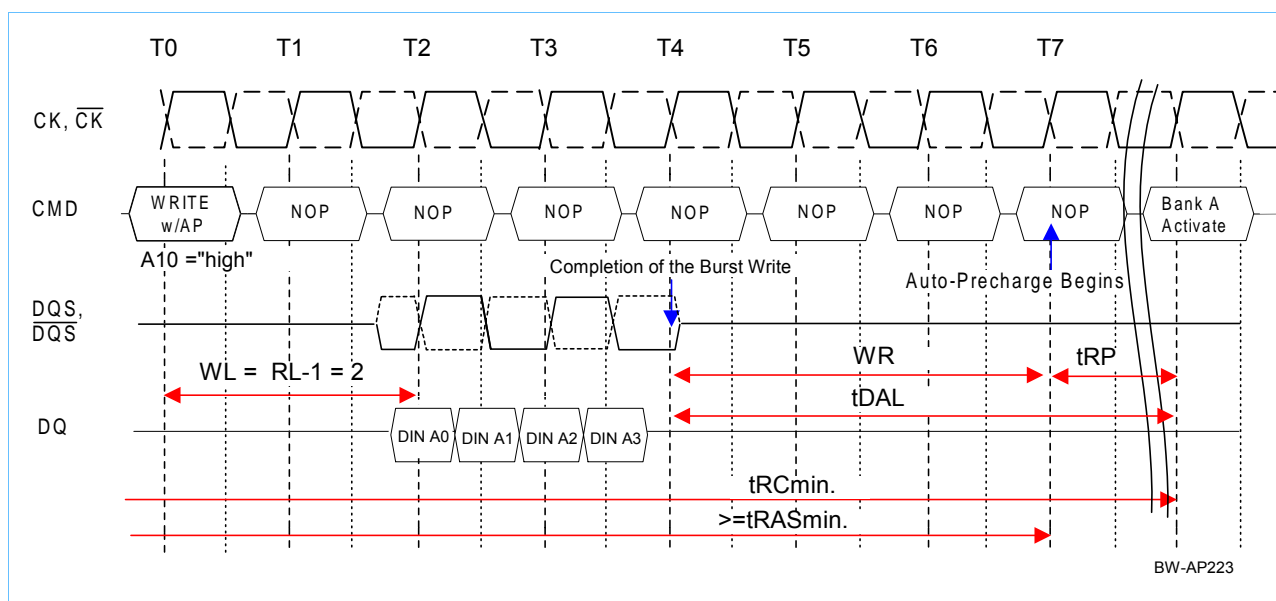

**Burst Write with Auto-Precharge (WR + tRP Limit): WL = 4, tDAL = 6 (WR = 3, tRP = 3), BL = 4**

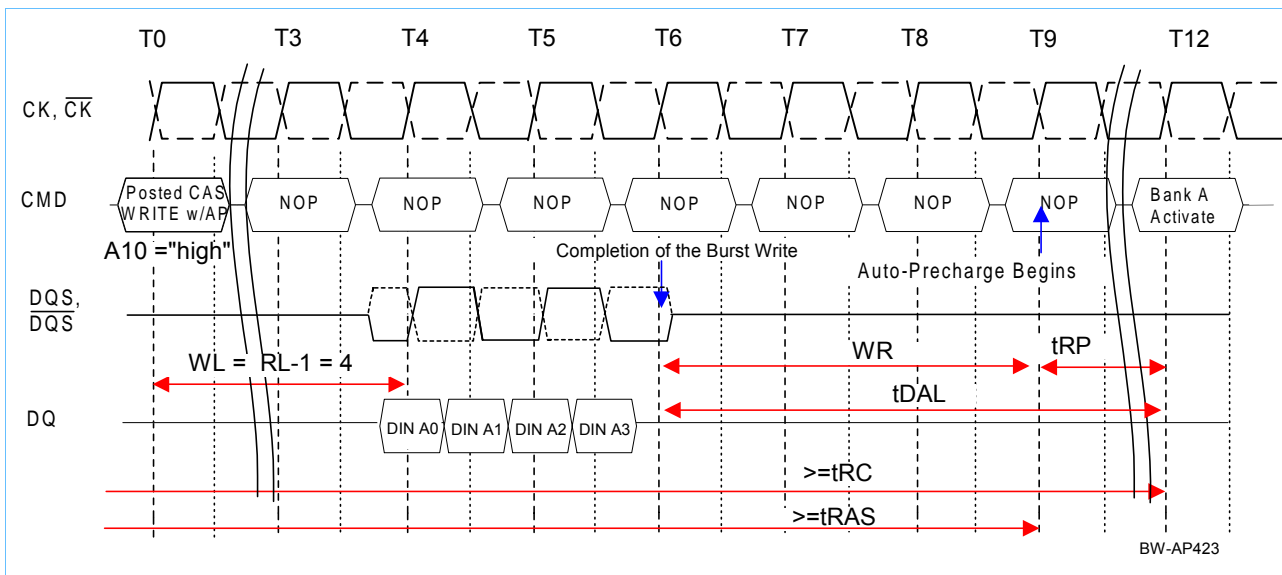

**2.8.3 Read or Write to Precharge Command Spacing Summary**

The following table summarizes the minimum command delays between Read, Read w/AP, Write, Write w/AP to the Precharge commands to the same banks and Precharge-All commands.

From Command	To Command	Minimum Delay between "From Command" to "To Command"	Units	Notes
READ	PRECHARGE (to same banks as READ)	$AL + BL/2 + \max(tRTP, 2) - 2 \cdot tck$	tCK	1, 2
	PRECHARGE-ALL	$AL + BL/2 + \max(tRTP, 2) - 2 \cdot tck$	tCK	1, 2
READ w/AP	PRECHARGE (to same banks as READ w/AP)	$AL + BL/2 + \max(tRTP, 2) - 2 \cdot tck$	tCK	1, 2
	PRECHARGE-ALL	$AL + BL/2 + \max(tRTP, 2) - 2 \cdot tck$	tCK	1, 2
WRITE	PRECHARGE (to same banks as WRITE)	$WL + BL/2 + tWR$	tCK	2
	PRECHARGE-ALL	$WL + BL/2 + tWR$	tCK	2
WRITE w/AP	PRECHARGE (to same banks as WRITE w/AP)	$WL + BL/2 + WR$	tCK	2
	PRECHARGE-ALL	$WL + BL/2 + WR$	tCK	2
PRECHARGE	PRECHARGE (to same banks as PRECHARGE)	$1 \cdot tck$	tCK	2
	PRECHARGE-ALL	$1 \cdot tck$	tCK	2
PRECHARGE-ALL	PRECHARGE	$1 \cdot tck$	tCK	2
	PRECHARGE-ALL	$1 \cdot tck$	tCK	2

Note 1:  $RTP[\text{cycles}] = RU\{tRTP(\text{ns}) / tCK(\text{ns})\}$ , where RU stands for round up.

Note 2: For a given bank, the precharge period should be counted from the latest precharge command, either one bank precharge or precharge-all, issued to that bank. The precharge period is satisfied after tRP or tRPall depending on the latest precharge command issued to that bank

### 2.8.4 Concurrent Auto-Precharge

DDR2 devices support the “Concurrent Auto-Precharge” feature. A Read with Auto-Precharge enabled, or a Write with Auto-Precharge enabled, may be followed by any command to the other bank, as long as that command does not interrupt the read or write data transfer, and all other related limitations (e.g. contention between Read data and Write data must be avoided externally and on the internal data bus.

The minimum delay from a Read or Write command with Auto-Precharge enabled, to a command to a different bank, is summarized in the table below. As defined, the  $WL = RL - 1$  for DDR2 devices which allows the command gap and corresponding data gaps to be minimized.

From Command	To Command (different bank, non-interrupting command)	Minimum Delay with Concurrent Auto-Pre- charge Support	Units	Note
WRITE w/AP	Read or Read w/AP	$(CL - 1) + (BL/2) + tWTR$	tCK	
	Write or Write w/AP	BL/2	tCK	
	Precharge or Activate	1	tCK	1)
Read w/AP	Read or Read w/AP	BL/2	tCK	
	Write or Write w/AP	BL/2 + 2	tCK	
	Precharge or Activate	1	tCK	1)
Note: 1) This rule only applies to a selective Precharge command to another banks, a Precharge-All command is illegal				

## 2.9 Refresh

DDR2 SDRAM requires a refresh of all rows in any rolling 64 ms interval. The necessary refresh can be generated in one of two ways: by explicit Auto-Refresh commands or by an internally timed Self-Refresh mode.

### 2.9.1 Auto-Refresh Command

Auto-Refresh is used during normal operation of the DDR2 SDRAM's. This command is non persistent, so it must be issued each time a refresh is required. The refresh addressing is generated by the internal refresh controller. This makes the address bits "Don't Care" during an Auto-Refresh command. The DDR2 SDRAM requires Auto-Refresh cycles at an average periodic interval of  $t_{REFI}$  (maximum).

When  $\overline{CS}$ ,  $\overline{RAS}$  and  $\overline{CAS}$  are held low and  $\overline{WE}$  high at the rising edge of the clock, the chip enters the Auto-Refresh mode. All banks of the SDRAM must be precharged and idle for a minimum of the precharge time ( $t_{RP}$ ) before the Auto-Refresh Command can be applied. An internal address counter supplies the addresses during the refresh cycle. No control of the external address bus is required once this cycle has started.

When the refresh cycle has completed, all banks of the SDRAM will be in the precharged (idle) state. A delay between the Auto-Refresh Command and the next Activate Command or subsequent Auto-Refresh Command must be greater than or equal to the Auto-Refresh cycle time ( $t_{RFC}$ ).

To allow for improved efficiency in scheduling and switching between tasks, some flexibility in the absolute refresh interval is provided. A maximum of eight Auto-Refresh commands can be posted to any given DDR2 SDRAM, meaning that the maximum absolute interval between any Auto-Refresh command and the next Auto-Refresh command is  $9 * t_{REFI}$ .

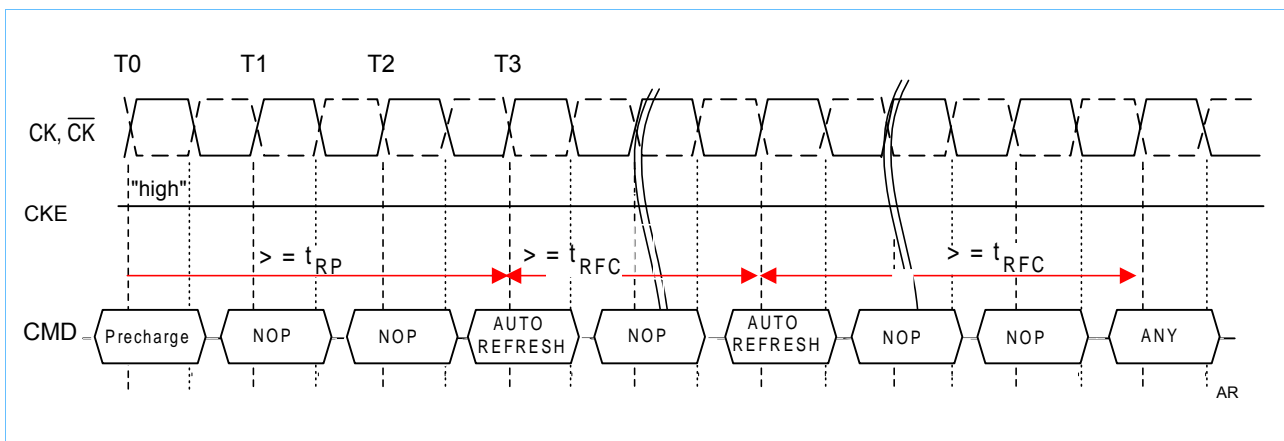

### 2.9.2 Self-Refresh Command

The Self-Refresh command can be used to retain data, even if the rest of the system is powered down. When in the Self-Refresh mode, the DDR2 SDRAM retains data without external clocking. The DDR2 SDRAM device has a built-in timer to accommodate Self-Refresh operation. The Self-Refresh Command is defined by having  $\overline{CS}$ ,  $\overline{RAS}$ ,  $\overline{CAS}$  and CKE held low with  $\overline{WE}$  high at the rising edge of the clock. ODT must be turned off before issuing Self Refresh command, by either driving ODT pin low or using EMRS(1) command. Once the command is registered, CKE must be held low to keep the device in Self-Refresh mode. The DLL is automatically disabled upon entering Self Refresh and is automatically enabled upon exiting Self Refresh. When the DDR2 SDRAM has entered Self-Refresh mode all of the external control signals, except CKE, are “don't care”. The DRAM initiates a minimum of one Auto Refresh command internally within tCKE period once it enters Self Refresh mode. The clock is internally disabled during Self-Refresh Operation to save power. The minimum time that the DDR2 SDRAM must remain in Self Refresh mode is tCKE. The user may change the external clock frequency or halt the external clock one clock after Self-Refresh entry is registered, however, the clock must be restarted and stable before the device can exit Self-Refresh operation.

The procedure for exiting Self Refresh requires a sequence of commands. First, the clock must be stable prior to CKE going back HIGH. Once Self-Refresh Exit command is registered, a delay of at least tXSNR must be satisfied before a valid command can be issued to the device to allow for any internal refresh in progress. CKE must remain high for the entire Self-Refresh exit period tXSRD for proper operation. Upon exit from Self Refresh, the DDR2 SDRAM can be put back into Self Refresh mode after tXSNR expires. NOP or deselect commands must be registered on each positive clock edge during the Self-Refresh exit interval tXSNR. ODT should be turned off during tXSRD.

The use of Self Refresh mode introduces the possibility that an internally timed refresh event can be missed when CKE is raised for exit from Self Refresh mode. Upon exit from Self Refresh, the DDR2 SDRAM requires a minimum of one extra auto refresh command before it is put back into Self Refresh Mode.

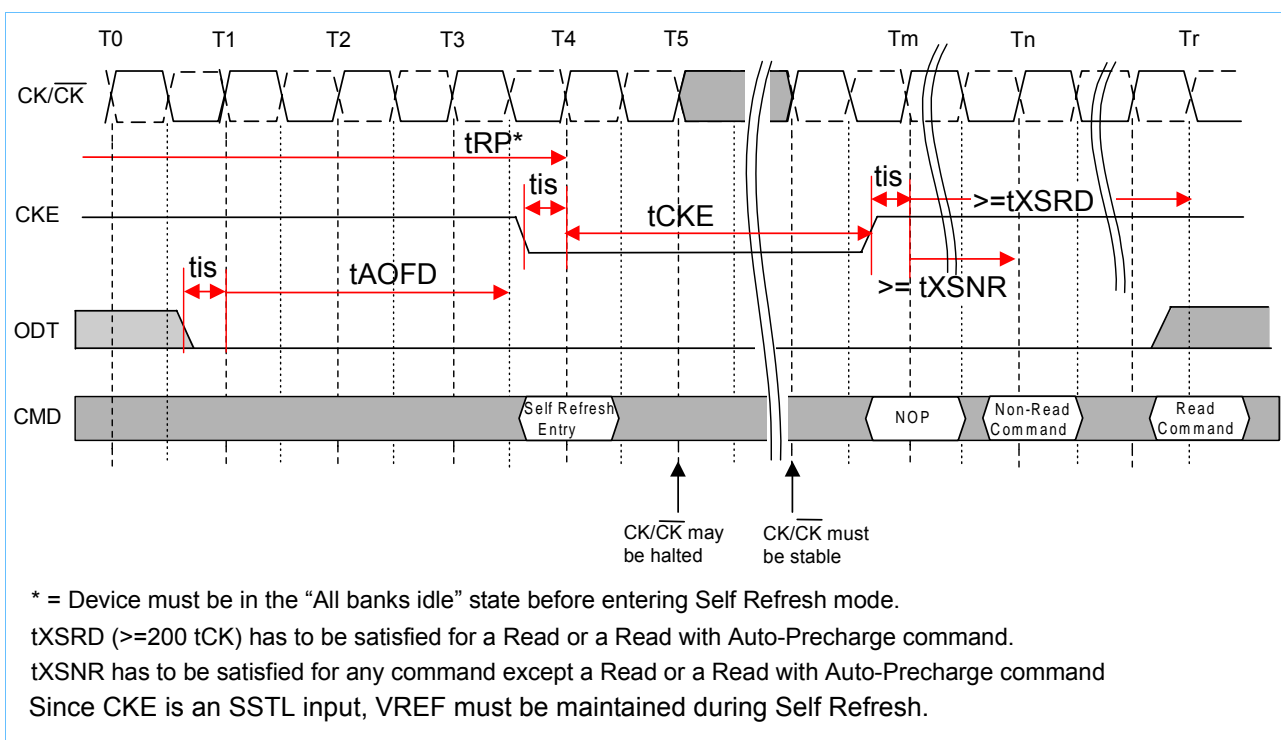

## 2.10 Power-Down

Power-down is synchronously entered when CKE is registered low, along with NOP or Deselect command. CKE is not allowed to go low while mode register or extended mode register command time, or read or write operation is in progress. CKE is allowed to go low while any other operation such as row activation, Precharge, Auto-Precharge or Auto-Refresh is in progress, but power-down IDD specification will not be applied until finishing those operations.

The DLL should be in a locked state when power-down is entered. Otherwise DLL should be reset after exiting power-down mode for proper read operation. DRAM design guarantees it's DLL in a locked state with any CKE intensive operations as long as DRAM controller complies with DRAM specifications.

If power-down occurs when all banks are precharged, this mode is referred to as *Precharge Power-down*; if power-down occurs when there is a row active in any bank, this mode is referred to as *Active Power-down*. For *Active Power-down* two different power saving modes can be selected within the MRS register, address bit A12. When A12 is set to "low" this mode is referred as "standard active power-down mode" and a fast power-down exit timing defined by the tXARD timing parameter can be used. When A12 is set to "high" this mode is referred as a power saving "low power active power-down mode". This mode takes longer to exit from the power-down mode and the tXARDS timing parameter has to be satisfied.

Entering power-down deactivates the input and output buffers, excluding CK,  $\overline{\text{CK}}$ , ODT and CKE. Also the DLL is disabled upon entering Precharge Power-down or slow exit active power-down, but the DLL is kept enabled during fast exit active power-down. In power-down mode, CKE low and a stable clock signal must be maintained at the inputs of the DDR2 SDRAM, and all other input signals are "Don't Care". Power-down duration is limited by 9 times tREFI of the device.

The power-down state is synchronously exited when CKE is registered high (along with a NOP or Deselect command). A valid, executable command can be applied with power-down exit latency, tXP, tXARD or tXARDS, after CKE goes high. Power-down exit latencies are defined in the AC spec table of this data sheet.

### Power-Down Entry

*Active Power-down mode* can be entered after an activate command. *Precharge Power-down mode* can be entered after a Precharge, Precharge-All or internal precharge command. It is also allowed to enter power-mode after an Auto-Refresh command or MRS / EMRS(1) command when tMRD is satisfied.

*Active Power-down mode* entry is prohibited as long as a Read Burst is in progress, meaning CKE should be kept high until the burst operation is finished. Therefore Active Power-Down mode entry after a Read or Read with Auto-Precharge command is allowed after  $RL + BL/2$  is satisfied.

*Active Power-down mode* entry is prohibited as long as a Write Burst and the internal write recovery is in progress. In case of a write command, active power-down mode entry is allowed when  $WL + BL/2 + tWTR$  is satisfied.

In case of a write command with Auto-Precharge, Power-down mode entry is allowed after the internal precharge command has been executed, which is  $WL + BL/2 + WR$  starting from the write with Auto-Precharge command. In case the DDR2 SDRAM enters the *Precharge Power-down mode*.

**Examples:**

**Active Power-Down Mode Entry and Exit after an Activate Command**

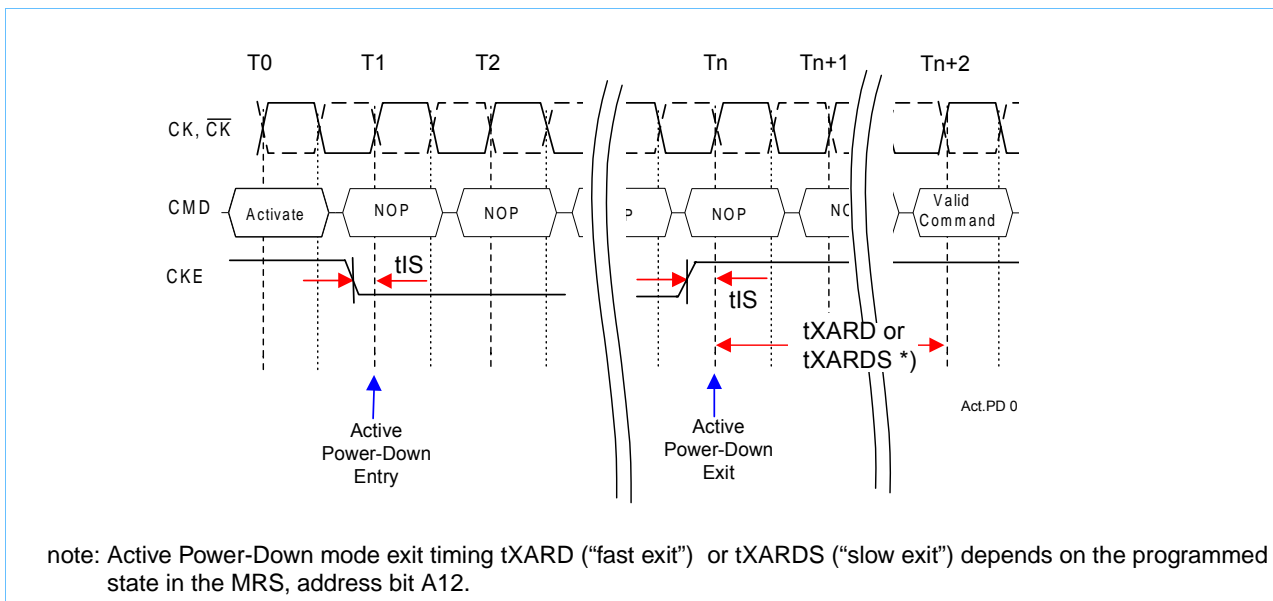

**Active Power-Down Mode Entry and Exit after a Read Command: RL = 4 (AL = 1, CL = 3), BL = 4**

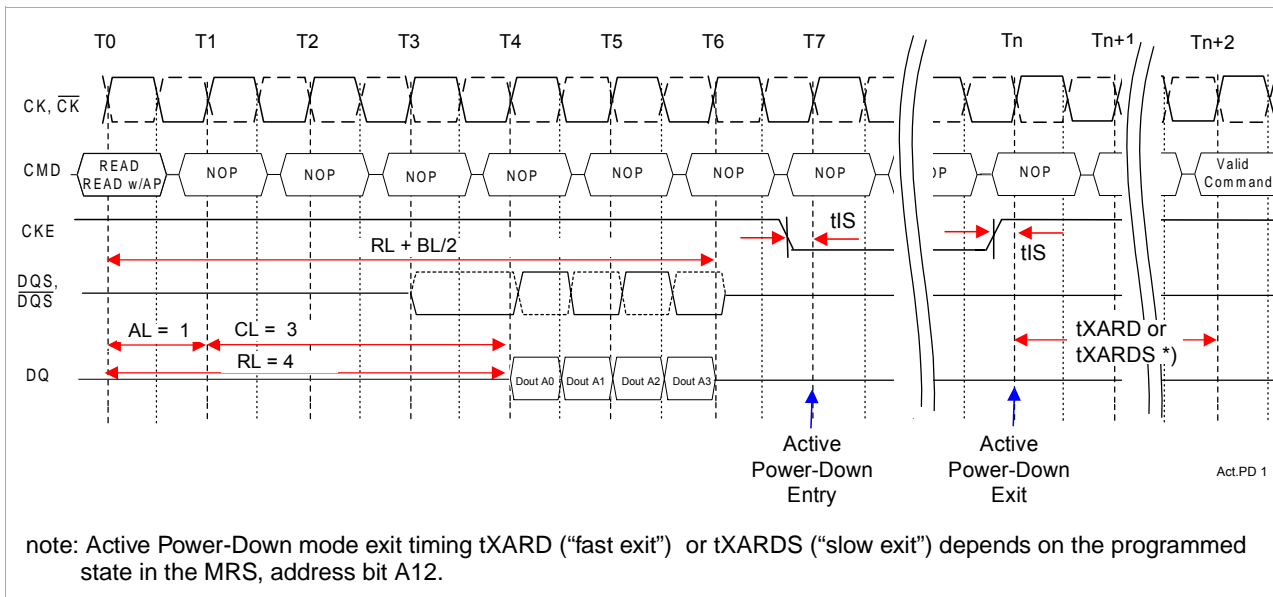



**Active Power-Down Mode Entry and Exit after a Write Command: WL = 2, tWTR = 2, BL = 4**

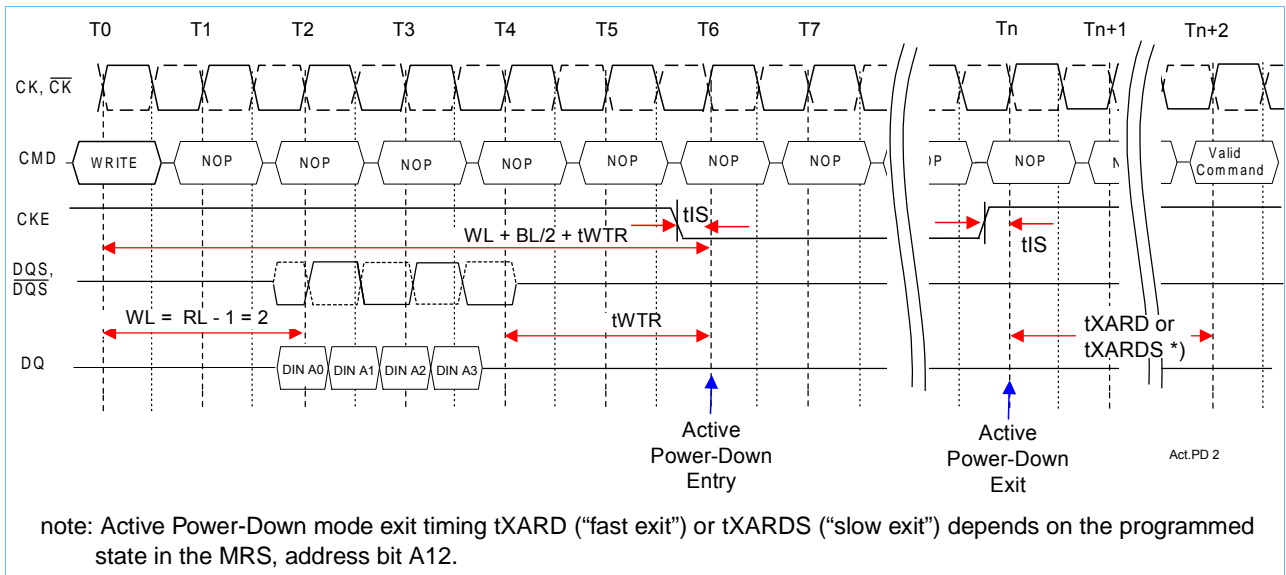

**Active Power-Down Mode Entry and Exit after a Write Command with AP: WL = 2, tWR = 3, BL = 4**

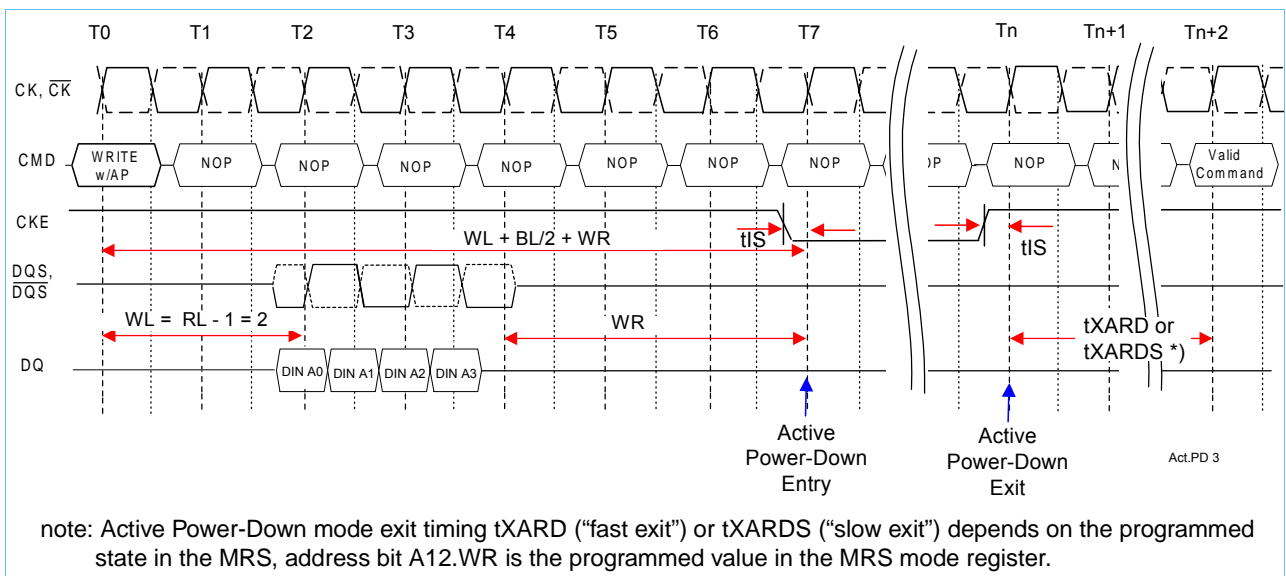

**Precharge Power Down Mode Entry and Exit**

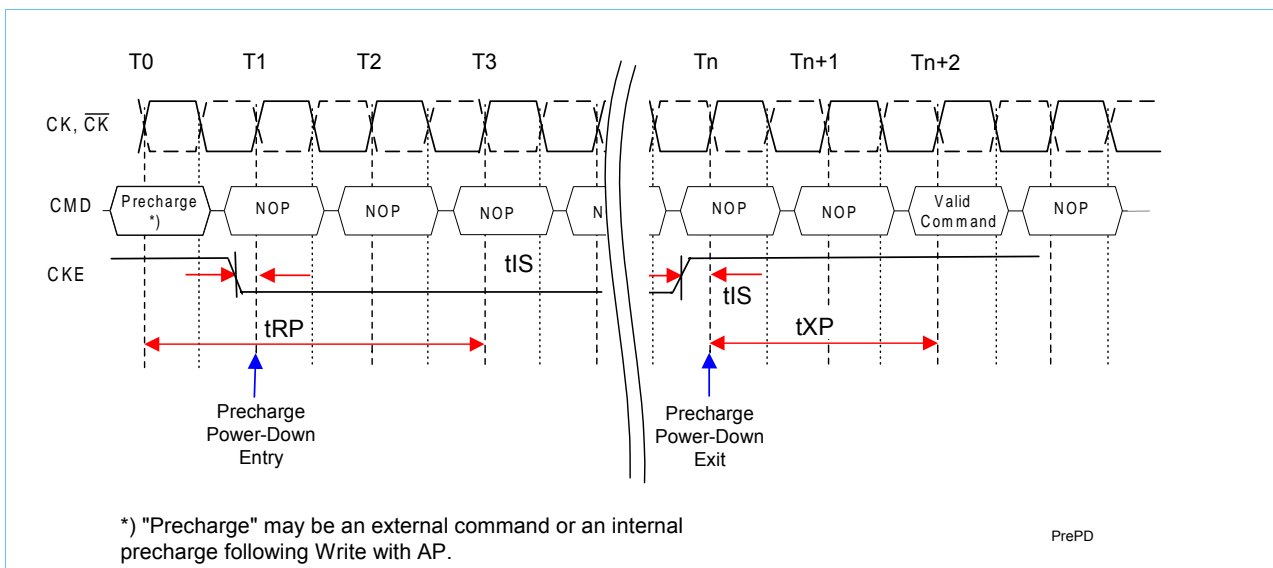

**Auto-Refresh command to Power-Down entry**

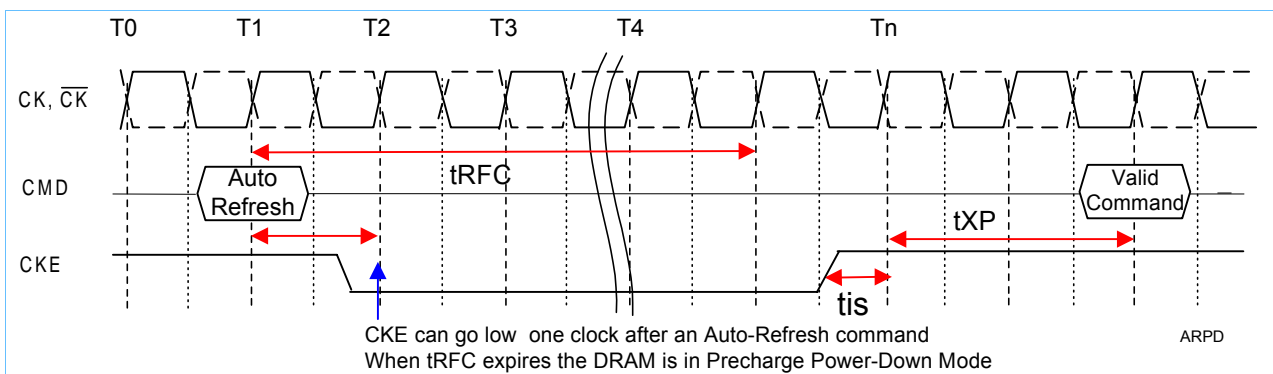

**MRS, EMRS command to Power-Down entry**

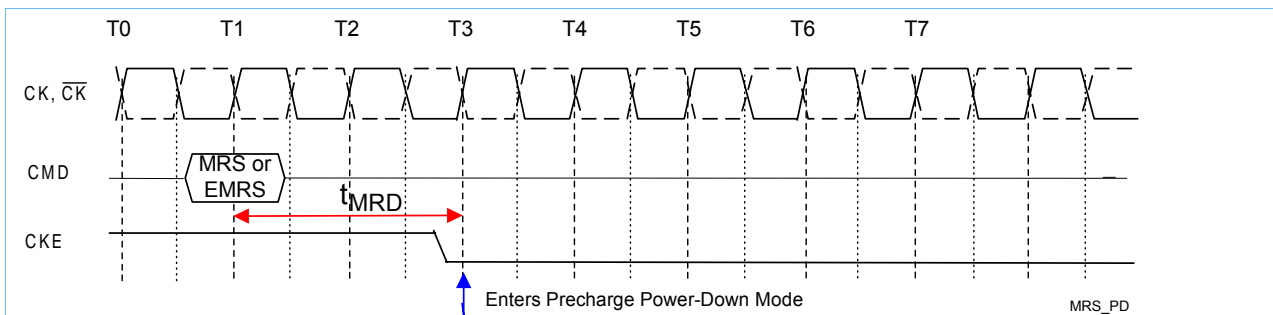

## 2.11 No Operation Command

### 2.11.1 No Operation Command (NOP)

The No Operation Command should be used in cases when the SDRAM is in a idle or a wait state. The purpose of the No Operation Command is to prevent the SDRAM from registering any unwanted commands between operations. A No Operation Command is registered when  $\overline{CS}$  is low with  $\overline{RAS}$ ,  $\overline{CAS}$ , and  $\overline{WE}$  held high at the rising edge of the clock. A No Operation Command will not terminate a previous operation that is still executing, such as a burst read or write cycle.

### 2.11.2 Deselect Command (DESEL)

The Deselect Command performs the same function as a No Operation Command. Deselect Command occurs when  $\overline{CS}$  is brought high, the  $\overline{RAS}$ ,  $\overline{CAS}$ , and  $\overline{WE}$  signals become don't care.

## 2.12 Input Clock Frequency Change

During operation the DRAM input clock frequency can be changed under the following conditions:

- a) During Self-Refresh operation
- b) DRAM is in Precharge Power-down mode and ODT is completely turned off.

The DDR2-SDRAM has to be in Precharged Power-down mode and idle. ODT must be already turned off and CKE must be at a logic "low" state. After a minimum of two clock cycles after  $t_{RP}$  and  $t_{AOFD}$  have been satisfied the input clock frequency can be changed. A stable new clock frequency has to be provided, before CKE can be changed to a "high" logic level again. After  $t_{XP}$  has been satisfied a DLL RESET command via EMRS(1) has to be issued. During the following DLL re-lock period of 200 clock cycles, ODT must remain off. After the DLL-re-lock period the DRAM is ready to operate with the new clock frequency.

### Example:

#### Input frequency change during Precharge Power-Down mode

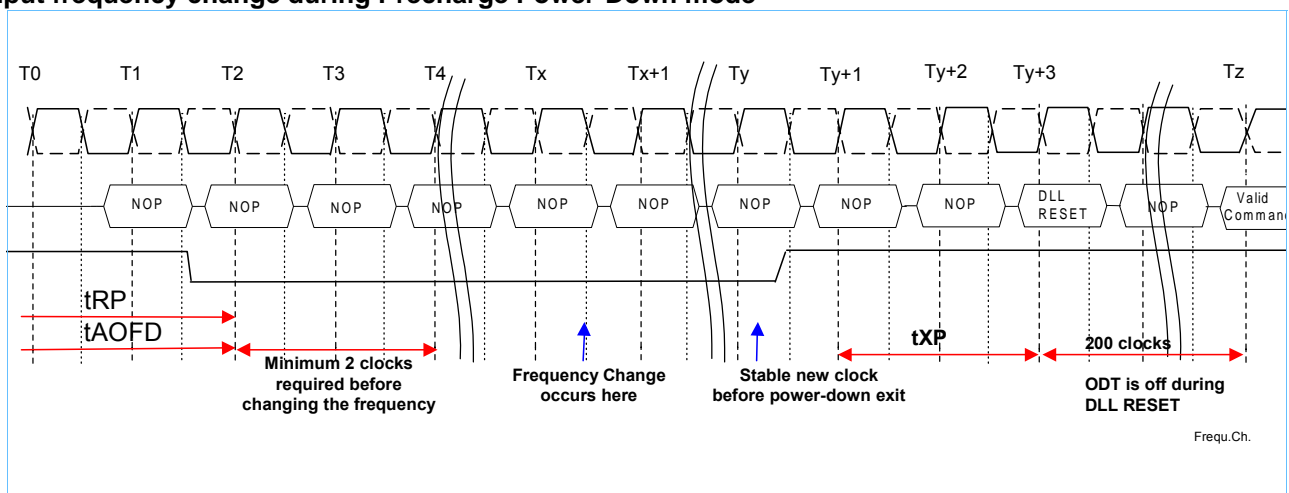

## 2.13 Asynchronous CKE Low Reset Event

In a given system, Asynchronous Reset event can occur at any time without prior knowledge. In this situation, memory controller is forced to drop CKE asynchronously low, immediately interrupting any valid operation. DRAM requires CKE to be maintained “high” for all valid operations as defined in this data sheet. If CKE asynchronously drops “low” during any valid operation DRAM is not guaranteed to preserve the contents of the memory array. If this event occurs, the memory controller must satisfy a time delay ( $t_{delay}$ ) before turning off the clocks. Stable clocks must exist at the input of DRAM before CKE is raised “high” again. The DRAM must be fully re-initialized as described the initialization sequence (section 2.2.1, step 4 thru 13). DRAM is ready for normal operation after the initialization sequence. See AC timing parametric table for  $t_{delay}$  specification.

### Asynchronous CKE Low Event

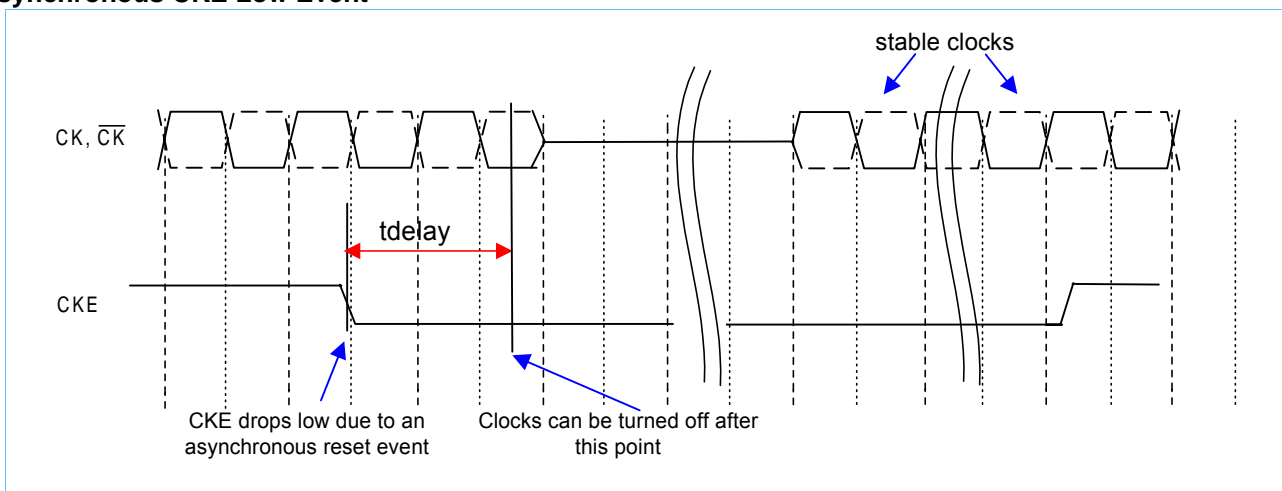

### 3. Truth Tables

#### 3.1 Command Truth Table

Function	CKE		$\overline{\text{CS}}$	$\overline{\text{RAS}}$	$\overline{\text{CAS}}$	$\overline{\text{WE}}$	BA0 BA1	A12-A11	A10	A9 - A0	Notes
	Previous Cycle	Current Cycle									
(Extended) Mode Register Set	H	H	L	L	L	L	BA	OP Code			1, 2
Auto-Refresh	H	H	L	L	L	H	X	X	X	X	1
Self-Refresh Entry	H	L	L	L	L	H	X	X	X	X	1
Self-Refresh Exit	L	H	H	X	X	X	X	X	X	X	1
Single Bank Precharge	H	H	L	L	H	L	BA	X	L	X	1,2
Precharge all Banks	H	H	L	L	H	L	X	X	H	X	1
Bank Activate	H	H	L	L	H	H	BA	Row Address			1, 2
Write	H	H	L	H	L	L	BA	Column	L	Column	1,2,3
Write with Auto-Precharge	H	H	L	H	L	L	BA	Column	H	Column	1,2,3
Read	H	H	L	H	L	H	BA	Column	L	Column	1,2,3
Read with Auto-Precharge	H	H	L	H	L	H	BA	Column	H	Column	1,2,3
No Operation	H	X	L	H	H	H	X	X	X	X	1
Device Deselect	H	X	H	X	X	X	X	X	X	X	1
Power Down Entry	H	L	H	X	X	X	X	X	X	X	1,4
			L	H	H	H					
Power Down Exit	L	H	H	X	X	X	X	X	X	X	1,4
			L	H	H	H					

- All DDR2 SDRAM commands are defined by states of  $\overline{\text{CS}}$ ,  $\overline{\text{WE}}$ ,  $\overline{\text{RAS}}$ ,  $\overline{\text{CAS}}$ , and CKE at the rising edge of the clock.
- Bank addresses (BAx) determine which bank is to be operated upon. For (E)MRS BAx selects an (Extended) Mode Register.
- Burst reads or writes at BL = 4 cannot be terminated. See sections "Reads interrupted by a Read" and "Writes interrupted by a Write" in section 2.4.6 for details.
- The Power Down Mode does not perform any refresh operations. The duration of Power Down is therefore limited by the refresh requirements outlined in section 2.7.
- The state of ODT does not affect the states described in this table. The ODT function is not available during Self Refresh.
- "X" means "H or L (but a defined logic level)".
- Operation that is not specified is illegal and after such an event, in order to guarantee proper operation, the DRAM must be powered down and then restarted through the specified initialization sequence before normal operation can continue.

### 3.2 Clock Enable (CKE) Truth Table for Synchronous Transitions

Current State <sup>2</sup>	CKE		Command (N) <sup>3,12</sup> $\overline{RAS}$ , $\overline{CAS}$ , $\overline{WE}$ , $\overline{CS}$	Action (N) <sup>3</sup>	Notes
	Previous Cycle <sup>1</sup> (N-1)	Current Cycle <sup>1</sup> (N)			
Power-Down	L	L	X	Maintain Power-Down	11, 13, 15
	L	H	DESELECT or NOP	Power-Down Exit	4, 8, 11, 13
Self Refresh	L	L	X	Maintain Self Refresh	11, 15
	L	H	DESELECT or NOP	Self Refresh Exit	4, 5, 9
Bank(s) Active	H	L	DESELECT or NOP	Active Power-Down Entry	4,8,10,11, 13
All Banks Idle	H	L	DESELECT or NOP	Precharge Power-Down Entry	4,8,10,11
	H	L	AUTOREFRESH	Self Refresh Entry	6, 9, 11, 13
Any State other than listed above	H	H	Refer to the Command Truth Table		7

1. CKE (N) is the logic state of CKE at clock edge N; CKE (N-1) was the state of CKE at the previous clock edge.
2. Current state is the state of the DDR2 SDRAM immediately prior to clock edge N.
3. Command (N) is the command registered at clock edge N, and Action (N) is a result of Command (N).
4. All states and sequences not shown are illegal or reserved unless explicitly described elsewhere in this document.
5. On Self Refresh Exit DESELECT or NOP commands must be issued on every clock edge occurring during the tXSNR period.  
Read commands may be issued only after tXSRD (200 clocks) is satisfied.
6. Self Refresh mode can only be entered from the All Banks Idle state.
7. Must be a legal command as defined in the Command Truth Table.
8. Valid commands for Power-Down Entry and Exit are NOP and DESELECT only.
9. Valid commands for Self Refresh Exit are NOP and DESELCT only.
10. Power-Down and Self Refresh can not be entered while Read or Write operations, (Extended) mode Register operations, Precharge or Refresh operations are in progress. See section 2.8 "Power Down" and section 2.7.2 "Self Refresh Command" for a detailed list of restrictions.
11. Minimum CKE high time is 3 clocks, minimum CKE low time is 3 clocks.
12. The state of ODT does not affect the states described in this table. The ODT function is not available during Self Refresh.
13. The Power-Down Mode does not perform any refresh operations. The duration of Power-Down Mode is therefor limited by the refresh requirements.
14. CKE must be maintained high while the device is in OCD calibration mode.
15. "X" means "don't care (including floating around VREF)" in Self Refresh and Power Down. However ODT must be driven high or low in Power Down if the ODT function is enabled (Bit A2 or A6 set to "1" in EMRS(1)).
16. Operation that is not specified is illegal and after such an event, in order to guarantee proper operation, the DRAM must be powered down and then restarted through the specified initialization sequence before normal operation can continue.

### 3.3 Data Mask (DM) Truth Table

Name (Function)	DM	DQs	Notes
Write Enable	L	Valid	1
Write Inhibit	H	X	1

1. Used to mask write data; provided coincident with the corresponding data.

## 4. Operating Conditions

### 4.1 Absolute Maximum Ratings

Symbol	Parameter	Rating	Units	Notes
VDD	Voltage on VDD pin relative to VSS	-1.0 to + 2.3	V	1
VDDQ	Voltage on VDDQ pin relative to VSS	-0.5 to + 2.3	V	1
VDDL	Voltage on VDDL pin relative to VSS	-0.5 to + 2.3	V	1
V <sub>IN</sub> , V <sub>OUT</sub>	Voltage on any pin relative to VSS	-0.5 to + 2.3	V	1
T <sub>STG</sub>	Storage Temperature	-55 to + 100	°C	1, 2

1. Stresses greater than those listed under "Absolute Maximum Ratings" may cause permanent damage to the device. This is a stress rating only and functional operation of the device at these or any other conditions above those indicated in the operational sections of this specification is not implied. Exposure to absolute maximum rating conditions for extended periods may affect reliability.

2. Storage Temperature is the case surface temperature on the center/top side of the DRAM. For the measurement conditions, please refer to JEDEC standard.

### 4.2 DRAM Component Operating Temperature Range

Symbol	Parameter	Rating	Units	Notes
T <sub>OPER</sub>	Operating Temperature	0 to 95	°C	1 ~ 4

1. Operating Temperature is the case surface temperature on the center / top side of the DRAM. For measurement conditions, please refer to the JEDEC document JEDEC51-2.

2. The operating temperature range are the temperatures where all DRAM specification will be supported. During operation, the DRAM case temperature must be maintained between 0 - 95°C under all other specification parameters.

3. Some application may require to operate the DRAM up to 95°C case temperature. In this case above 85°C case temperature the Auto-Refresh command interval has to be reduced to tREFI = 3.9 μs.

4. Self-Refresh period is hard-coded in the chip and therefore it is imperative that the system ensures the DRAM is below 85°C case temperature before initiating self-refresh operation.

## 5. AC & DC Operating Conditions

### 5.1 DC Operating Conditions

#### 5.1.1 Recommended DC Operating Conditions (SSTL\_18)

Symbol	Parameter	Rating			Units	Notes
		Min.	Typ.	Max.		
VDD	Supply Voltage	1.7	1.8	1.9	V	1
VDDDL	Supply Voltage for DLL	1.7	1.8	1.9	V	1
VDDQ	Supply Voltage for Output	1.7	1.8	1.9	V	1
VREF	Input Reference Voltage	0.49 * VDDQ	0.5 * VDDQ	0.51 * VDDQ	V	2, 3
VTT	Termination Voltage	VREF - 0.04	VREF	VREF + 0.04	V	4

- VDDQ tracks with VDD, VDDDL tracks with VDD. AC parameters are measured with VDD, VDDQ and VDDDL tied together.
- The value of VREF may be selected by the user to provide optimum noise margin in the system. Typically the value of VREF is expected to be about 0.5 x VDDQ of the transmitting device and VREF is expected to track variations in VDDQ.
- Peak to peak ac noise on VREF may not exceed +/- 2% VREF (dc).
- VTT is not applied directly to the device. VTT is a system supply for signal termination resistors, is expected to be set equal to VREF and must track variations in die dc level of VREF.

#### 5.1.2 ODT DC Electrical Characteristics

Parameter / Condition	Symbol	min.	nom.	max.	Units	Notes
Rtt <sub>(eff)</sub> impedance value for EMRS(1)(A6,A2)=0,1; 75 ohm	Rtt1 <sub>(eff)</sub>	60	75	90	Ω	1
Rtt <sub>(eff)</sub> impedance value for EMRS(1)(A6,A2)=1,0; 150 ohm	Rtt2 <sub>(eff)</sub>	120	150	180	Ω	1
Deviation of VM with respect to VDDQ / 2	delta VM	- 6.00		+ 6.00	%	2

1) Measurement Definition for Rtt<sub>(eff)</sub>:  
 Apply VIH<sub>(ac)</sub> and VIL<sub>(ac)</sub> to test pin separately, then measure current I(VIH<sub>ac</sub>) and I(VIL<sub>ac</sub>) respectively.  

$$Rtt_{(eff)} = (VIH_{(ac)} - VIL_{(ac)}) / (I(VIH_{ac}) - I(VIL_{ac}))$$

2) Measurement Definition for VM:  
 Measure voltage (VM) at test pin (midpoint) with no load:  

$$\text{delta VM} = ((2 * VM / VDDQ) - 1) \times 100\%$$

#### 5.1.3 Input and Output Leakage Currents:

Symbol	Parameter / Condition	min.	max.	Units	Notes
I <sub>IL</sub>	Input Leakage Current; any input 0V < V <sub>IN</sub> < VDD	-2	+2	μA	1
I <sub>OL</sub>	Output Leakage Current; 0V < V <sub>OUT</sub> < VDDQ	-5	+5	μA	2

notes: 1) all other pins not under test = 0V  
 2) DQ's, DQS, DQS and ODT are disabled



## 5.2 DC & AC Logic Input Levels

DDR2 SDRAM pin timing are specified for either single ended or differential mode depending on the setting of the EMRS(1) "Enable  $\overline{DQS}$ " mode bit; timing advantages of differential mode are realized in system design. The method by which the DDR2 SDRAM pin timing are measured is mode dependent. In single ended mode, timing relationships are measured relative to the rising or falling edges of DQS crossing at VREF. In differential mode, these timing relationships are measured relative to the crosspoint of DQS and its complement,  $\overline{DQS}$ . This distinction in timing methods is verified by design and characterization but not subject to production test. In single ended mode, the  $\overline{DQS}$  (and  $\overline{RDQS}$ ) signals are internally disabled and don't care.

### 5.2.1 Single-ended DC & AC Logic Input Levels

Symbol	Parameter	Min.	Max.	Units
VIH (dc)	DC input logic high	VREF + 0.125	VDDQ + 0.3	V
VIL (dc)	DC input low	- 0.3	VREF - 0.125	V
VIH (ac)	AC input logic high	VREF + 0.250	-	V
VIL (ac)	AC input low	-	VREF - 0.250	V

### 5.2.2 Single-ended AC Input Test Conditions

Symbol	Condition	Value	Units	Notes
VREF	Input reference voltage	0.5 * VDDQ	V	1, 2
VSWING(max)	Input signal maximum peak to peak swing	1.0	V	1, 2
SLEW	Input signal minimum slew rate	1.0	V / ns	3, 4

1. This timing and slew rate definition is valid for all single-ended signals except tis, tih, tds, tdh.
2. Input waveform timing is referenced to the input signal crossing through the VREF level applied to the device under test.
3. The input signal minimum slew rate is to be maintained over the range from VIL(dc)max to VIH(ac)min for rising edges and the range from VIH(dc)min to VIL(ac)max for falling edges as shown in the below figure.
4. AC timings are referenced with input waveforms switching from VIL(ac) to VIH(ac) on the positive transitions and VIH(ac) to VIL(ac) on the negative transitions.

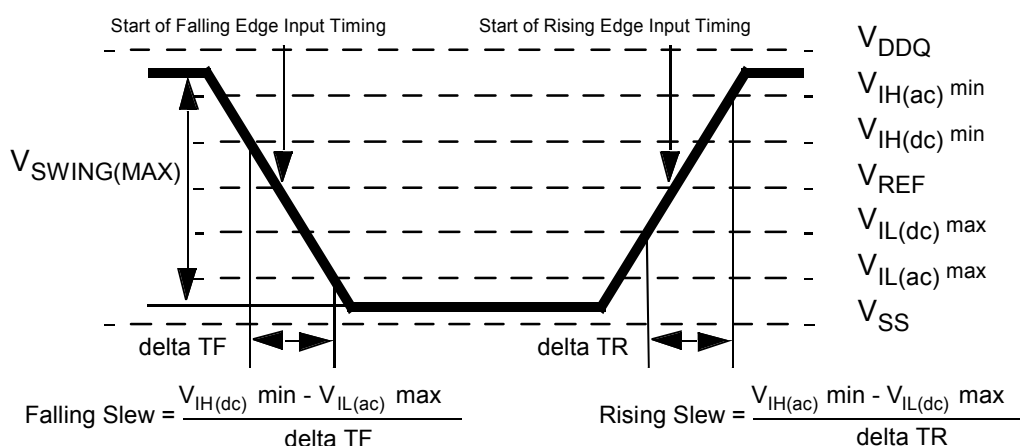

### 5.2.3 Differential DC and AC Input and Output Logic Levels

Symbol	Parameter	min.	max.	Units	Notes
VIN(dc)	DC input signal voltage	-0.3	VDDQ + 0.3		1
VID(dc)	DC differential input voltage	0.25	VDDQ + 0.6		2
VID(ac)	AC differential input voltage	0.5	VDDQ + 0.6	V	3
VIX(ac)	AC differential cross point input voltage	$0.5 * VDDQ - 0.175$	$0.5 * VDDQ + 0.175$	V	4
VOX(ac)	AC differential cross point output voltage	$0.5 * VDDQ - 0.125$	$0.5 * VDDQ + 0.125$	V	5

notes:

- 1) VIN(dc) specifies the allowable DC execution of each input of differential pair such as CK,  $\overline{CK}$ , DQS,  $\overline{DQS}$  etc.
- 2) VID(dc) specifies the input differential voltage VTR - VCP required for switching. The minimum value is equal to VIH(dc) - VIL(dc).
- 3) VID(ac) specifies the input differential voltage VTR - VCP required for switching. The minimum value is equal to VIH(ac) - VIL(ac).
- 4) The value of VIX(ac) is expected to equal  $0.5 * VDDQ$  of the transmitting device and VIX(ac) is expected to track variations in VDDQ. VIX(ac) indicates the voltage at which differential input signals must cross.
- 5) The value of VOX(ac) is expected to equal  $0.5 * VDDQ$  of the transmitting device and VOX(ac) is expected to track variations in VDDQ. VOX(ac) indicates the voltage at which differential input signals must cross.

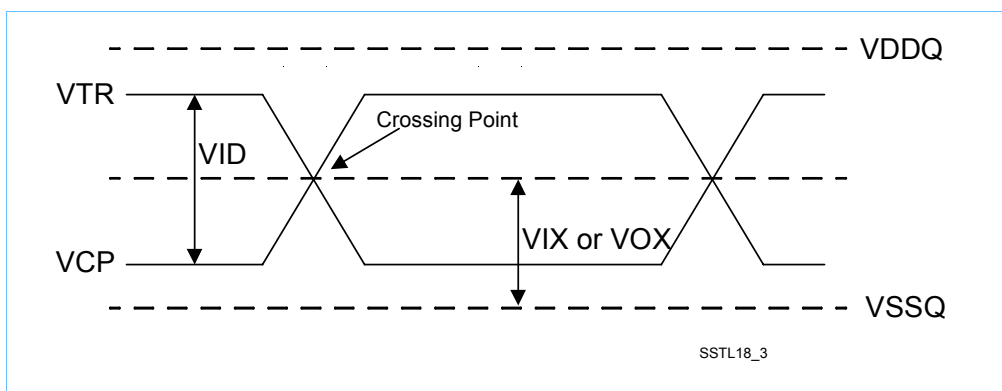

### 5.3 Output Buffer Levels

#### 5.3.1 SSTL\_18 Output DC Current Drive

Symbol	Parameter	SSTL_18 Class II	Units	Notes
I <sub>OH</sub>	Output Minimum Source DC Current	-13.4	mA	1, 3, 4
I <sub>OL</sub>	Output Minimum Sink DC Current	13.4	mA	2, 3, 4

1. VDDQ = 1.7 V; V<sub>OUT</sub> = 1.42 V. (V<sub>OUT</sub>-VDDQ) / I<sub>OH</sub> must be less than 21 ohm for values of V<sub>OUT</sub> between VDDQ and VDDQ - 280 mV.  
2. VDDQ = 1.7 V; V<sub>OUT</sub> = 280 mV. V<sub>OUT</sub> / I<sub>OL</sub> must be less than 21 ohm for values of V<sub>OUT</sub> between 0V and 280 mV.  
3. The dc value of VREF applied to the receiving device is set to VTT  
4. The values of I<sub>OH</sub>(dc) and I<sub>OL</sub>(dc) are based on the conditions given in note 1 and 2. They are used to test drive current capability to ensure VIHmin, plus a noise margin and VILmax, minus a noise margin are delivered to an SSTL\_18 receiver. The actual current values are derived by shifting the desired driver operating points along 21 ohm load line to define a convenient current for measurement.

#### 5.3.2 SSTL\_18 Output AC Test Conditions

Symbol	Parameter	SSTL_18 Class II	Units	Notes
V <sub>OH</sub>	Minimum Required Output Pull-up	V <sub>TT</sub> + 0.603	V	1
V <sub>OL</sub>	Maximum Required Output Pull-down	V <sub>TT</sub> - 0.603	V	1
V <sub>OTR</sub>	Output Timing Measurement Reference Level	0.5 * VDDQ	V	2

1. SSTL\_18 test load for V<sub>OH</sub> and V<sub>OL</sub> is different from the reference load described in section 8.1 of this datasheet. The SSTL\_18 test load has a 20 Ohm series resistor additionally to the 25 Ohm termination resistor into VTT. The SSTL\_18 definition assumes that +/- 335 mV must be developed across the effectively 25 Ohm termination resistor (13.4 mA x 25 Ohm = 335 mV). With an additional series resistor of 20 Ohm this translates into a minimum requirement of 603 mV swing relative to VTT, at the output device (13.4 mA \* 45 Ohm) = 603 mV).  
2. The VDDQ of the device under test is referenced.

#### 5.3.3 OCD “Off-Chip Driver” Default Characteristics

Symbol	Description	min.	nominal	max.	Unit	Notes
-	Output Impedance	12.6	18	23.4	Ohms	1,2
-	Pull-up / Pull down mismatch	0	-	4	Ohms	1, 2, 3
-	Output Impedance step size for OCD calibration	0	-	1.5	Ohms	8
Sout	Output Slew Rate	1.5	-	5.0	V / ns	1, 4, 5, 6, 7

1) VDDQ = 1.8 V ± 0.1 V; VDD = 1.8 V ± 0.1 V.  
2) Impedance measurement condition for output source dc current: VDDQ = 1.7 V, VOUT = 1420 mV; (VOUT-VDDQ) / I<sub>OH</sub> must be less than 23.4 ohms for values of VOUT between VDDQ and VDDQ - 280 mV. Impedance measurement condition for output sink dc current: VDDQ = 1.7 V; VOUT = -280 mV; VOUT / I<sub>OL</sub> must be less than 23.4 ohms for values of VOUT between 0 V and 280 mV.  
3) Mismatch is absolute value between pull-up and pull-down, both are measured at same temperature and voltage.  
4) Slew rates measured from VIL(ac) to VIH(ac) with the load specified in Section 8.2.  
5) The absolute value of the slew rate as measured from DC to DC is equal to or greater than the slew rate as measured from AC to AC. This is verified by design and characterisation but not subject to production test.  
6) DRAM output slew rate specification applies to 400, 533 and 667 MT/s speed bins.  
7) Timing skew due to DRAM output slew rate mis-match between DQS /  $\overline{DQS}$  and associated DQ's is included in tDQSQ and tQHS specification.  
8) This represents the step size when the OCD is near 18 ohms at nominal conditions across all process parameters and represents only the DRAM uncertainty. A 0 Ohm value (no calibration) can only be achieved if the OCD impedance is 18 +/- 0.75 ohms under nominal conditions.

### 5.4 Default Output V-I Characteristics

DDR2 SDRAM output driver characteristics are defined for full strength default operation as selected by the EMRS(1) bits A7~A9 = '111'. Figures in Section 5.3.5 and 5.3.6 show the driver characteristics graphically and the tables show the same data suitable for input into simulation tools.

#### 5.4.1 Full Strength Default Pull-up Driver Characteristics

Voltage (V)	Pull-up Driver Current [mA]			
	Minimum	Nominal Default low	Nominal Default high	Maximum
0.2	-8.5	-11.1	-11.8	-15.9
0.3	-12.1	-16.0	-17.0	-23.8
0.4	-14.7	-20.3	-22.2	-31.8
0.5	-16.4	-24.0	-27.5	-39.7
0.6	-17.8	-27.2	-32.4	-47.7
0.7	-18.6	-29.8	-36.9	-55.0
0.8	-19.0	-31.9	-40.8	-62.3
0.9	-19.3	-33.4	-44.5	-69.4
1.0	-19.7	-34.6	-47.7	-75.3
1.1	-19.9	-35.5	-50.4	-80.5
1.2	-20.0	-36.2	-52.5	-84.6
1.3	-20.1	-36.8	-54.2	-87.7
1.4	-20.2	-37.2	-55.9	-90.8
1.5	-20.3	-37.7	-57.1	-92.9
1.6	-20.4	-38.0	-58.4	-94.9
1.7	-20.6	-38.4	-59.6	-97.0
1.8		-38.6	-60.8	-99.1
1.9				-101.1

The driver characteristics evaluation conditions are:  
 Nominal Default 25°C (Tcase), VDDQ = 1.8 V, typical process  
 Minimum 95°C (Tcase), VDDQ = 1.7V, slow-slow process  
 Maximum 0 °C (Tcase). VDDQ = 1.9 V, fast-fast process

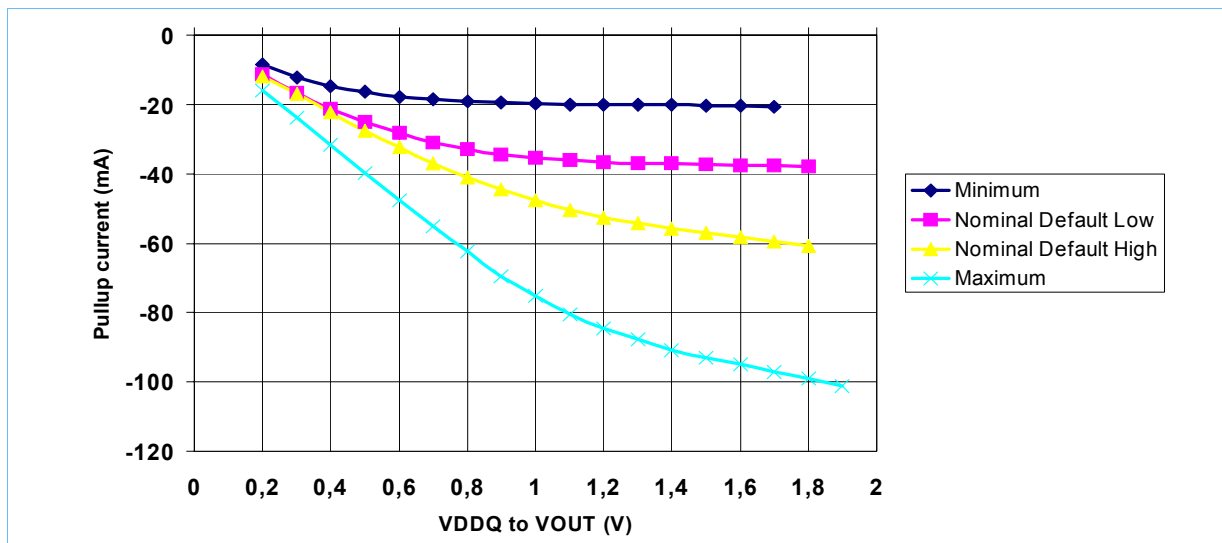

### 5.4.2 Full Strength Default Pull-down Driver Characteristics

Voltage (V)	Pull-down Driver Current [mA]			
	Minimum	Nominal Default low	Nominal Default high	Maximum
0.2	8.5	11.3	11.8	15.9
0.3	12.1	16.5	16.8	23.8
0.4	14.7	21.2	22.1	31.8
0.5	16.4	25.0	27.6	39.7
0.6	17.8	28.3	32.4	47.7
0.7	18.6	30.9	36.9	55.0
0.8	19.0	33.0	40.9	62.3
0.9	19.3	34.5	44.6	69.4
1.0	19.7	35.5	47.7	75.3
1.1	19.9	36.1	50.4	80.5
1.2	20.0	36.6	52.6	84.6
1.3	20.1	36.9	54.2	87.7
1.4	20.2	37.1	55.9	90.8
1.5	20.3	37.4	57.1	92.9
1.6	20.4	37.6	58.4	94.9
1.7	20.6	37.7	59.6	97.0
1.8		37.9	60.9	99.1
1.9				101.1

The driver characteristics evaluation conditions are:  
 Nominal Default 25°C (Tcase), VDDQ = 1.8 V, typical process  
 Minimum 95°C (Tcase), VDDQ = 1.7V, slow-slow process  
 Maximum 0 °C (Tcase). VDDQ = 1.9 V, fast-fast process

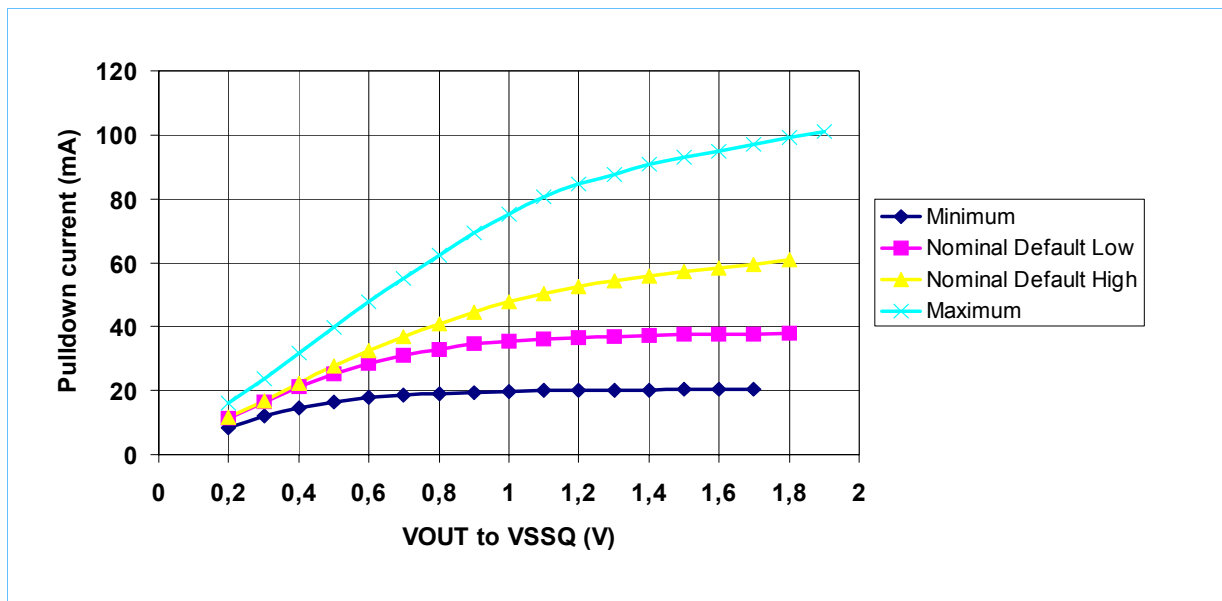

### 5.4.3 Calibrated Output Driver V-I Characteristics

DDR2 SDRAM output driver characteristics are defined for full strength calibrated operation as selected by the procedure outlined in the Off-Chip Driver (OCD) Impedance Adjustment. The following tables show the data in tabular format suitable for input into simulation tools. The nominal points represent a device at exactly 18 ohms. The nominal low and nominal high values represent the range that can be achieved with a maximum 1.5 ohms step size with no calibration error at the exact nominal conditions only (i.e. perfect calibration procedure, 1.5 ohm maximum step size guaranteed by specification). Real system calibration error needs to be added to these values. It must be understood that these V-I curves are represented here or in supplier IBIS models need to be adjusted to a wider range as a result of any system calibration error. Since this is a system specific phenomena, it cannot be quantified here. The values in the calibrated tables represent just the DRAM portion of uncertainty while looking at one DQ only. If the calibration procedure is used, it is possible to cause the device to operate outside the bounds of the default device characteristics tables and figure. In such a situation, the timing parameters in the specification cannot be guaranteed. It is solely up to the system application to ensure that the device is calibrated between the minimum and maximum default values at all times. If this can't be guaranteed by the system calibration procedure, re-calibration policy and uncertainty with DQ to DQ variation, it is recommended that only the default values to be used. The nominal maximum and minimum values represent the change in impedance from nominal low and high as a result of voltage and temperature change from the nominal condition to the maximum and minimum conditions. If calibrated at an extreme condition, the amount of variation could be as much as from the nominal minimum to the nominal maximum or vice versa.

#### Full Strength Calibrated Pull-down Driver Characteristics

Voltage (V)	Calibrated Pull-down Driver Current [mA]				
	Nominal Minimum (21 Ohms)	Normal Low (18.75 Ohms)	Nominal (18 ohms)	Normal High (17.25 Ohms)	Nominal Maximum (15 Ohms)
0.2	9.5	10.7	11.5	11.8	13.3
0.3	14.3	16.0	16.6	17.4	20.0
0.4	18.7	21.0	21.6	23.0	27.0

The driver characteristics evaluation conditions are:  
 Nominal 25°C (Tcase), VDDQ = 1.8 V, typical process  
 Nominal Low and Nominal High 25°C (Tcase), VDDQ = 1.8V, any process  
 Nominal Minimum 95°C (Tcase), VDDQ = 1.7 V, any process  
 Nominal Maximum 0°C (Tcase), VDDQ = 1.9 V, any process

#### Full Strength Calibrated Pull-up Driver Characteristics

Voltage (V)	Calibrated Pull-up Driver Current [mA]				
	Nominal Minimum (21 Ohms)	Normal Low (18.75 Ohms)	Nominal (18 ohms)	Normal High (17.25 Ohms)	Nominal Maximum (15 Ohms)
0.2	-9.5	-10.7	-11.4	-11.8	-13.3
0.3	-14.3	-16.0	-16.5	-17.4	-20.0
0.4	-18.3	-21.0	-21.2	-23.0	-27.0

The driver characteristics evaluation conditions are:  
 Nominal 25°C (Tcase), VDDQ = 1.8 V, typical process  
 Nominal Low and Nominal High 25°C (Tcase), VDDQ = 1.8V, any process  
 Nominal Minimum 95°C (Tcase), VDDQ = 1.7 V, any process  
 Nominal Maximum 0°C (Tcase), VDDQ = 1.9 V, any process

### 5.5 Input / Output Capacitance

Symbol	Parameter	min.	max.	Units
CCK	Input capacitance, CK and $\overline{\text{CK}}$	1.0	2.0	pF
CDCK	Input capacitance delta, CK and $\overline{\text{CK}}$	-	0.25	pF
CI	Input capacitance, all other input-only pins	1.0	2.0	pF
CDI	Input capacitance delta, all other input-only pins	-	0.25	pF
CIO	Input/output capacitance, DQ, DM, DQS, $\overline{\text{DQS}}$ , RDQS, $\overline{\text{RDQS}}$	3.0	4.0	pF
CDIO	Input/output capacitance delta, DQ, DM, DQS, $\overline{\text{DQS}}$ , RDQS, $\overline{\text{RDQS}}$	-	0.5	pF

### 5.6 Power & Ground Clamp V-I Characteristics

Power and Ground clamps are provided on address (A0~A12, BA0, BA1),  $\overline{\text{RAS}}$ ,  $\overline{\text{CAS}}$ ,  $\overline{\text{CS}}$ ,  $\overline{\text{WE}}$ , CKE and ODT pins. The V-I characteristics for pins with clamps is shown in the following table:

Voltage across clamp (V)	Minimum Power Clamp Current (mA)	Minimum Ground Clamp Current (mA)
0.0	0	0
0.1	0	0
0.2	0	0
0.3	0	0
0.4	0	0
0.5	0	0
0.6	0	0
0.7	0	0
0.8	0.1	0.1
0.9	1.0	1.0
1.0	2.5	2.5
1.1	4.7	4.7
1.2	6.8	6.8
1.3	9.1	9.1
1.4	11.0	11.0
1.5	13.5	13.5
1.6	16.0	16.0
1.7	18.2	18.2
1.8	21.0	21.0

## 6. IDD Specifications and Measurement Conditions

### 6.1 IDD Specifications

(VDDQ = 1.8V ± 0.1V; VDD = 1.8V ± 0.1V, 0 °C to T<sub>CASEmax</sub>.)

Symbol	Parameter/Condition	I/O	-5 DDR2 -400	-3.7 DDR2 -533	-3 & -3S DDR2 - 667	Unit	
			max.	max.	max.		
I <sub>DD0</sub>	Operating Current	all	50	55	60	mA	
I <sub>DD1</sub>	Operating Current	all	55	60	65	mA	
I <sub>DD2P</sub>	Precharge Power-Down Current	all	4	4	4	mA	
I <sub>DD2N</sub>	Precharge Standby Current	all	28	36	45	mA	
I <sub>DD2Q</sub>	Precharge Quiet Standby Current:	all	20	25	30	mA	
I <sub>DD3P</sub>	Active Power-Down Standby Current	MRS(12)=0	all	13	16	20	mA
		MRS(12)=1	all	4	4	4	mA
I <sub>DD3N</sub>	Active Standby Current	all	30	35	40	mA	
I <sub>DD4R</sub>	Operating Current Burst Read	x4/x8	60	70	80	mA	
		x16	70	80	90		
I <sub>DD4W</sub>	Operating Current Burst Write	x4/x8	70	85	100	mA	
		x16	90	100	115		
I <sub>DD5B</sub>	Burst Auto-Refresh Current (t <sub>RFC</sub> =t <sub>RFCmin</sub> .)	all	80	85	90	mA	
I <sub>DD5D</sub>	Distributed Auto-Refresh Current (t <sub>RFC</sub> =7.8µs)	all	6	6	6	mA	
I <sub>DD6</sub>	Self-Refresh Current for standard products	all	4	4	4	mA	
I <sub>DD6</sub>	Self-Refresh Current for low power products	all	2	2	2	mA	
I <sub>DD7</sub>	Operating Current	x4/x8	125	135	145	mA	
		x16	140	150	160		



## 6.2 IDD Measurement Conditions

(VDDQ = 1.8V ± 0.1V; VDD = 1.8V ± 0.1V)

Symbol	Parameter/Condition
I <sub>DD0</sub>	<b>Operating Current - One bank Active - Precharge</b> tCK = tCK(IDD); tRC = tRC(IDD); tRAS = tRASmin(IDD); CKE is HIGH, $\overline{CS}$ is HIGH between valid commands. Address and control inputs are SWITCHING; Data bus inputs are SWITCHING;
I <sub>DD1</sub>	<b>Operating Current - One bank Active - Read - Precharge</b> IOUT = 0 mA; BL = 4, tCK = tCK(IDD), tRC = tRC(IDD); tRAS = tRASmin(IDD); tRCD = tRCD(IDD), CL = CL(IDD); AL = 0; CKE is HIGH, $\overline{CS}$ is HIGH between valid commands; Address bus inputs are SWITCHING, Data bus inputs are SWITCHING;
I <sub>DD2P</sub>	<b>Precharge Power-Down Current:</b> All banks idle; CKE is LOW; tCK = tCK(IDD); Other control and address inputs are STABLE, Data Bus inputs are FLOATING.
I <sub>DD2N</sub>	<b>Precharge Standby Current:</b> All banks idle; $\overline{CS}$ is HIGH; CKE is HIGH; tCK = tCK(IDD); Other control and address bus inputs are SWITCHING; Data bus inputs are SWITCHING.
I <sub>DD2Q</sub>	<b>Precharge Quiet Standby Current:</b> All banks idle; $\overline{CS}$ is HIGH; CKE is HIGH; tCK = tCK(IDD); Other control and address bus inputs are STABLE; Data bus inputs are FLOATING.
I <sub>DD3P(0)</sub>	<b>Active Power-Down Current:</b> All banks open; tCK = tCK(IDD); CKE is LOW; Other control and address inputs are STABLE; Data Bus inputs are FLOATING. MRS A12 bit is set to "0"(Fast Power-down Exit);
I <sub>DD3P(1)</sub>	<b>Active Power-Down Current:</b> All banks open; tCK = tCK(IDD); CKE is LOW; Other control and address inputs are STABLE; Data Bus inputs are FLOATING. MRS A12 bit is set to "1"(Slow Power-down Exit);
I <sub>DD3N</sub>	<b>Active Standby Current:</b> All banks open; tCK = tCK(IDD); tRAS = tRASmax(IDD); tRP = tRP(IDD); CKE is HIGH; $\overline{CS}$ is HIGH between valid commands; Other control and address inputs are SWITCHING; Data Bus inputs are SWITCHING.
I <sub>DD4R</sub>	<b>Operating Current - Burst Read:</b> All banks open; Continuous burst reads; BL = 4; AL = 0, CL = CL(IDD); tCK = tCK(IDD); tRAS = tRASmax(IDD); tRP = tRP(IDD); CKE is HIGH, $\overline{CS}$ is HIGH between valid commands; Address inputs are SWITCHING; Data bus inputs are SWITCHING; IOUT = 0mA.
I <sub>DD4W</sub>	<b>Operating Current - Burst Write:</b> All banks open; Continuous burst writes; BL = 4; AL = 0, CL = CL(IDD); tCK = tCK(IDD); tRAS = tRASmax(IDD); tRP = tRP(IDD); CKE is HIGH, $\overline{CS}$ is HIGH between valid commands; Address inputs are SWITCHING; Data Bus inputs are SWITCHING;
I <sub>DD5B</sub>	<b>Burst Auto-Refresh Current:</b> tCK = tCK(IDD); Refresh command every tRFC = tRFC(IDD) interval; CKE is HIGH, $\overline{CS}$ is HIGH between valid commands; Other control and address inputs are SWITCHING; Data bus inputs are SWITCHING.
I <sub>DD5D</sub>	<b>Distributed Auto-Refresh Current:</b> tCK = tCK(IDD); Refresh command every tREFI=7.8 μs interval; CKE is LOW and $\overline{CS}$ is HIGH between valid commands; Other control and address inputs are SWITCHING; Data bus inputs are SWITCHING
I <sub>DD6</sub>	<b>Self-Refresh Current:</b> CKE ≤ 0.2V; external clock off, CK and $\overline{CK}$ at 0V; Other control and address inputs are FLOATING; Data Bus inputs are FLOATING.
I <sub>DD7</sub>	<b>All Bank Interleave Read Current:</b> 1. All banks interleaving reads, IOUT = 0 mA; BL = 4, CL=CL(IDD), AL = tRCD(IDD) - 1*tCK(IDD); tCK = tCK(IDD), tRC = tRC(IDD), tRRD = tRRD(IDD); CKE is HIGH, $\overline{CS}$ is high between valid commands, Address bus inputs are STABLE during DESELECTS; Data bus is SWITCHING. 2. Timing pattern: - <b>DDR2 -400 -333:</b> A0 RA0 A1 RA1 A2 RA2 A3 RA3 D D D D - <b>DDR2 -533 -444:</b> A0 RA0 D A1 RA1 D A2 RA2 D A3 RA3 D D D D - <b>DDR2 -667 -444:</b> A0 RA0 D D A1 RA1 D D A2 RA2 D D A3 RA3 D D D D - <b>DDR2 -667 -555:</b> A0 RA0 D D A1 RA1 D D A2 RA2 D D A3 RA3 D D D D D D 3. Legend: Activate, RA=Read with Auto-Precharge, D=DESELECT

1. IDD specifications are tested after the device is properly initialized.  
 2. IDD parameter are specified with ODT disabled.  
 3. Data Bus consists of DQ, DM, DQS,  $\overline{DQS}$ , RDQS,  $\overline{RDQS}$ , LDQS,  $\overline{LDQS}$ , UDQS and  $\overline{UDQS}$ .  
 4. Definitions for IDD:  
 LOW is defined as VIN ≤ VILAC(max.); HIGH is defined as VIN ≥ VIHAC(min.);  
 STABLE is defined as inputs are stable at a HIGH or LOW level  
 FLOATING is defined as inputs are VREF = VDDQ / 2  
 SWITCHING is defined as:  
 Inputs are changing between HIGH and LOW every other clock (once per two clocks) for address and control signals, and inputs changing between HIGH and LOW every other data transfer (once per clock) for DQ signals not including mask or strobes.  
 5. Timing parameter minimum and maximum values for IDD current measurements are defined in the following table.

## 6.2 IDD Measurement Conditions (cont'd)

For testing the IDD parameters, the following timing parameters are used:

Parameter	Symbol	-5 DDR2 -400	-3.7 DDR2 -533	-3S DDR2 - 667	-3 DDR2 - 667	Unit
		3-3-3	4-4-4	5-5-5	4-4-4	
CAS Latency	CL(IDD)	3	4	5	4	tCK
Clock Cycle Time	tCK(IDD)	5	3.75	3	3	ns
Active to Read or Write delay	tRCD(IDD)	15	15	15	12	ns
Active to Active / Auto-Refresh command period	tRC(IDD)	60	60	60	57	ns
Active bank A to Active bank B command delay	1 kB page size tRRD(IDD)	7.5	7.5	7.5	7.5	ns
Active to Precharge Command	tRASmin(IDD)	45	45	45	45	ns
	tRASmax(IDD)	70000	70000	70000	70000	ns
Precharge Command Period	tRP(IDD)	15	15	15	12	ns
Auto-Refresh to Active / Auto-Refresh command period	tRFC(IDD)	75	75	75	75	ns

## 6.3 ODT (On Die Termination) Current

The ODT function adds additional current consumption to the DDR2 SDRAM when enabled by the EMRS(1). Depending on address bits A6 & A2 in the EMRS(1) a “week” or “strong” termination can be selected. The current consumption for any terminated input pin, depends on the input pin is in tri-state or driving “0” or “1”, as long a ODT is enabled during a given period of time.

### ODT current per terminated input pin:

		EMRS(1) State	min.	typ.	max.	Unit
<b>Enabled ODT current per DQ</b> added IDDQ current for ODT enabled; ODT is HIGH; Data Bus inputs are FLOATING	IODTO	A6 = 0, A2 = 1	tbd.	tbd.	7.5	mA/DQ
		A6 = 1, A2 = 0	tbd.	tbd.	3.75	mA/DQ
<b>Active ODT current per DQ</b> added IDDQ current for ODT enabled; ODT is HIGH; worst case of Data Bus inputs are STABLE or SWITCHING.	IODTT	A6 = 0, A2 = 1	tbd.	tbd.	15	mA/DQ
		A6 = 1, A2 = 0	tbd.	tbd.	7.5	mA/DQ
note: For power consumption calculations the ODT duty cycle has to be taken into account						

## 7. Electrical Characteristics & AC Timing - Absolute Specification

### 7.1 Timing Parameter by Speed Grade - DDR2-400 & DDR2-533

( $V_{DDQ} = 1.8V \pm 0.1V$ ;  $V_{DD} = 1.8V \pm 0.1V$ ) (notes 1-4)

Symbol	Parameter	-5 DDR2-400-333		-3.7 DDR2-533-444		Unit	Notes	
		min.	max	min.	max			
$t_{AC}$	DQ output access time from CK / $\overline{CK}$	- 600	+ 600	-500	+500	ps		
$t_{DQSCK}$	DQS output access time from CK / $\overline{CK}$	- 500	+ 500	-450	+450	ps		
$t_{CH}$	CK, $\overline{CK}$ high-level width	0.45	0.55	0.45	0.55	$t_{CK}$		
$t_{CL}$	CK, $\overline{CK}$ low-level width	0.45	0.55	0.45	0.55	$t_{CK}$		
$t_{HP}$	Clock half period	min ( $t_{CL}$ , $t_{CH}$ )		min ( $t_{CL}$ , $t_{CH}$ )			5	
$t_{CK}$	Clock cycle time	CL = 3	5000	8000	5000	8000	ps	6
		CL = 4 & 5	5000	8000	3750	8000	ps	6
$t_{IS}$	Address and control input setup time	350	-	250	-	ps	7	
$t_{IH}$	Address and control input hold time	475	-	375	-	ps	7	
$t_{DS}$	DQ and DM input setup time	150	-	100	-	ps	8	
$t_{DS}$	DQ and DM input hold time	275	-	225	-	ps	8	
$t_{IPW}$	Address and control input pulse width (each input)	0.6	-	0.6	-	$t_{CK}$		
$t_{DIPW}$	DQ and DM input pulse width (each input)	0.35	-	0.35	-	$t_{CK}$		
$t_{HZ}$	Data-out high-impedance time from CK / $\overline{CK}$	-	$t_{ACmax}$	-	$t_{ACmax}$	ps	9	
$t_{LZ(DQ)}$	DQ low-impedance time from CK / $\overline{CK}$	$2 \cdot t_{ACmin}$	$t_{ACmax}$	$2 \cdot t_{ACmin}$	$t_{ACmax}$	ps	9	
$t_{LZ(DQS)}$	DQS low-impedance from CK / $\overline{CK}$	$t_{ACmin}$	$t_{ACmax}$	$t_{ACmin}$	$t_{ACmax}$	ps	9	
$t_{DQSQ}$	DQS-DQ skew (for DQS & associated DQ signals)	-	350	-	300	ps	18	
$t_{QHS}$	Data hold skew factor	-	450	-	400	ps		
$t_{QH}$	Data output hold time from DQS	$t_{HP} - t_{QHS}$		$t_{HP} - t_{QHS}$				
$t_{DQSS}$	Write command to 1st DQS latching transition	WL-0.25	WL+0.25	WL-0.25	WL+0.25	$t_{CK}$		
$t_{DQSL,H}$	DQS input low (high) pulse width (write cycle)	0.35	-	0.35	-	$t_{CK}$		
$t_{DSS}$	DQS falling edge to CK setup time (write cycle)	0.2	-	0.2	-	$t_{CK}$		
$t_{DSH}$	DQS falling edge hold time from CK (write cycle)	0.2	-	0.2	-	$t_{CK}$		
$t_{MRD}$	Mode register set command cycle time	2	-	2	-	$t_{CK}$		
$t_{WPRE}$	Write preamble	0.25	-	0.25	-	$t_{CK}$		
$t_{WPST}$	Write postamble	0.40	0.60	0.40	0.60	$t_{CK}$	10	
$t_{RPRE}$	Read preamble	0.9	1.1	0.9	1.1	$t_{CK}$	9	
$t_{RPST}$	Read postamble	0.40	0.60	0.40	0.60	$t_{CK}$	9	
$t_{RAS}$	Active to Precharge command	40	70000	45	70000	ns	11	
$t_{RC}$	Active to Active/Auto-Refresh command period	55	-	60	-	ns		
$t_{RFC}$	Auto-Refresh to Active/Auto-Refresh command period	75	-	75	-	ns	12	
$t_{RCD}$	Active to Read or Write delay (with and without Auto-Precharge)	15	-	15	-	ns	13	
$t_{RP}$	Precharge command period	15	-	15	-	ns		

**7.1 Timing Parameter by Speed Grade - DDR2-400 & DDR2-533**
 $(V_{DDQ} = 1.8V \pm 0.1V; V_{DD} = 1.8V \pm 0.1V)$  (notes 1-4)

Symbol	Parameter		-5 DDR2-400-333		-3.7 DDR2-533-444		Unit	Notes
			min.	max	min.	max		
t <sub>R</sub> RD	Active bank A to Active bank B command period	x4, x8 & x16 (1k page size)	7.5	-	7.5	-	ns	
t <sub>CCD</sub>	$\overline{\text{CAS A}}$ to $\overline{\text{CAS B}}$ Command Period		2		2		t <sub>CK</sub>	
t <sub>WR</sub>	Write recovery time		15	-	15	-	ns	
t <sub>DAL</sub>	Auto-Precharge write recovery + precharge time		WR+t <sub>RP</sub>	-	WR+t <sub>RP</sub>	-	t <sub>CK</sub>	14
t <sub>WTR</sub>	Internal Write to Read command delay		10	-	7.5	-	ns	15
t <sub>RTP</sub>	Internal Read to Precharge command delay		7.5	-	7.5	-	ns	
t <sub>XARD</sub>	Exit power down to any valid command (other than NOP or Deselect)		2	-	2	-	t <sub>CK</sub>	16
t <sub>XARDS</sub>	Exit active power-down mode to Read command (slow exit, lower power)		6 - AL	-	6 - AL	-	t <sub>CK</sub>	16
t <sub>XP</sub>	Exit precharge power-down to any valid command (other than NOP or Deselect)		2	-	2	-	t <sub>CK</sub>	
t <sub>XSRD</sub>	Exit Self-Refresh to read command		200	-	200	-	t <sub>CK</sub>	
t <sub>XSNR</sub>	Exit Self-Refresh to non-Read command		t <sub>RFC</sub> +10		t <sub>RFC</sub> +10		ns	
t <sub>CKE</sub>	CKE minimum high and low pulse width		3		3		t <sub>CK</sub>	
t <sub>REFI</sub>	Average periodic refresh Interval	0°C - 85°C	-	7.8	-	7.8	μs	19
		85°C - 95°C	-	3.9	-	3.9	μs	
t <sub>OIT</sub>	OCD drive mode output delay		0	12	0	12	ns	
t <sub>DELAY</sub>	Minimum time clocks remain ON after CKE asynchronously drops LOW		t <sub>IS</sub> +t <sub>CK</sub> +t <sub>IH</sub>	-	t <sub>IS</sub> +t <sub>CK</sub> +t <sub>IH</sub>	-	ns	17

Timing that is not specified is illegal and after such an event, in order to guarantee proper operation, the DRAM must be powered down and then restarted through the specified initialization sequence before normal operation can continue.

**7.2 Timing Parameter by Speed Grade - DDR2-667**
 $(V_{DDQ} = 1.8V \pm 0.1V; V_{DD} = 1.8V \pm 0.1V)$  (notes 1-4)

Symbol	Parameter	-3S DDR2-667-555		-3 DDR2-667-444		Unit	Notes	
		min.	max	min.	max			
$t_{AC}$	DQ output access time from CK / $\overline{CK}$	-450	+450	-450	+450	ps		
$t_{DQSCK}$	DQS output access time from CK / $\overline{CK}$	-400	+400	-400	+400	ps		
$t_{CH}$	CK, $\overline{CK}$ high-level width	0.45	0.55	0.45	0.55	$t_{CK}$		
$t_{CL}$	CK, $\overline{CK}$ low-level width	0.45	0.55	0.45	0.55	$t_{CK}$		
$t_{HP}$	Clock half period	min ( $t_{CL}$ , $t_{CH}$ )		min ( $t_{CL}$ , $t_{CH}$ )			5	
$t_{CK}$	Clock cycle time	CL = 3	5000	8000	5000	8000	ps	6
		CL = 4	5000	8000	3000	8000	ps	
		CL = 5	3000	8000	3000	8000	ps	
$t_{IS}$	Address and control input setup time	150	-	150	-	ps	7	
$t_{IH}$	Address and control input hold time	275	-	275	-	ps	7	
$t_{DS}$	DQ and DM input setup time	50	-	50	-	ps	8	
$t_{DH}$	DQ and DM input hold time	175	-	175	-	ps	8	
$t_{IPW}$	Address and control input pulse width (each input)	0.6	-	0.6	-	$t_{CK}$		
$t_{DIPW}$	DQ and DM input pulse width (each input)	0.35	-	0.35	-	$t_{CK}$		
$t_{HZ}$	Data-out high-impedance time from CK / $\overline{CK}$	-	$t_{ACmax}$	-	$t_{ACmax}$	ps	9	
$t_{LZ(DQ)}$	DQ low-impedance time from CK / $\overline{CK}$	$2 \cdot t_{ACmin}$	$t_{ACmax}$	$2 \cdot t_{ACmin}$	$t_{ACmax}$	ps	9	
$t_{LZ(DQS)}$	DQS low-impedance from CK / $\overline{CK}$	$t_{ACmin}$	$t_{ACmax}$	$t_{ACmin}$	$t_{ACmax}$	ps	9	
$t_{DQSQ}$	DQS-DQ skew (for DQS & associated DQ signals)	-	250	-	250	ps	18	
$t_{QHS}$	Data hold skew factor	-	350	-	350	ps		
$t_{QH}$	Data output hold time from DQS	$t_{HP} - t_{QHS}$		$t_{HP} - t_{QHS}$				
$t_{DQSS}$	Write command to 1st DQS latching transition	WL-0.25	WL+0.25	WL-0.25	WL+0.25	$t_{CK}$		
$t_{DQSL,H}$	DQS input low (high) pulse width (write cycle)	0.35	-	0.35	-	$t_{CK}$		
$t_{DSS}$	DQS falling edge to CK setup time (write cycle)	0.2	-	0.2	-	$t_{CK}$		
$t_{DSH}$	DQS falling edge hold time from CK (write cycle)	0.2	-	0.2	-	$t_{CK}$		
$t_{MRD}$	Mode register set command cycle time	2	-	2	-	$t_{CK}$		
$t_{WPRE}$	Write preamble	0.35	-	0.35	-	$t_{CK}$		
$t_{WPST}$	Write postamble	0.40	0.60	0.40	0.60	$t_{CK}$	10	
$t_{RPRE}$	Read preamble	0.9	1.1	0.9	1.1	$t_{CK}$	9	
$t_{RPST}$	Read postamble	0.40	0.60	0.40	0.60	$t_{CK}$	9	
$t_{RAS}$	Active to Precharge command	45	70000	45	70000	ns	11	
$t_{RC}$	Active to Active/Auto-Refresh command period	60	-	57	-	ns		
$t_{RFC}$	Auto-Refresh to Active/Auto-Refresh command period	75	-	75	-	ns	12	
$t_{RCD}$	Active to Read or Write delay (with and without Auto-Precharge)	15	-	12	-	ns	13	

## 7.2 Timing Parameter by Speed Grade - DDR2-667

( $V_{DDQ} = 1.8V \pm 0.1V$ ;  $V_{DD} = 1.8V \pm 0.1V$ ) (notes 1-4)

Symbol	Parameter		-3S DDR2-667-555		-3 DDR2-667-444		Unit	Notes
			min.	max	min.	max		
t <sub>RP</sub>	Precharge command period		15	-	12	-	ns	
t <sub>RRD</sub>	Active bank A to Active bank B command period	x4, x8 & x16 (1k page size)	7.5	-	7.5	-	ns	
t <sub>CCD</sub>	$\overline{CAS}$ A to $\overline{CAS}$ B Command Period		2		2		t <sub>CK</sub>	
t <sub>WR</sub>	Write recovery time		15	-	15	-	ns	
t <sub>DAL</sub>	Auto-Precharge write recovery + precharge time		WR+t <sub>RP</sub>	-	WR+t <sub>RP</sub>	-	t <sub>CK</sub>	14
t <sub>WTR</sub>	Internal Write to Read command delay		7.5	-	7.5	-	ns	15
t <sub>RTP</sub>	Internal Read to Precharge command delay		7.5	-	7.5	-	ns	
t <sub>XARD</sub>	Exit power down to any valid command (other than NOP or Deselect)		2	-	2	-	t <sub>CK</sub>	16
t <sub>XARDS</sub>	Exit active power-down mode to Read command (slow exit, lower power)		6 - AL	-	6 - AL	-	t <sub>CK</sub>	16
t <sub>XP</sub>	Exit precharge power-down to any valid command (other than NOP or Deselect)		2	-	2	-	t <sub>CK</sub>	
t <sub>XSRD</sub>	Exit Self-Refresh to read command		200	-	200	-	t <sub>CK</sub>	
t <sub>XSNR</sub>	Exit Self-Refresh to non-Read command		t <sub>RFC</sub> +10		t <sub>RFC</sub> +10		ns	
t <sub>CKE</sub>	CKE minimum high and low pulse width		3		3		t <sub>CK</sub>	
t <sub>REFI</sub>	Average periodic refresh Interval	0°C - 85°C	-	7.8	-	7.8	μs	19
		85°C - 95°C	-	3.9	-	3.9	μs	
t <sub>OIT</sub>	OCD drive mode output delay		0	12	0	12	ns	
t <sub>DELAY</sub>	Minimum time clocks remain ON after CKE asynchronously drops LOW		t <sub>IS</sub> +t <sub>CK</sub> +t <sub>IH</sub>	-	t <sub>IS</sub> +t <sub>CK</sub> +t <sub>IH</sub>	-	ns	17

Timing that is not specified is illegal and after such an event, in order to guarantee proper operation, the DRAM must be powered down and then restarted through the specified initialization sequence before normal operation can continue.

**7.3 ODT AC Electrical Characteristics and Operating Conditions (all speed bins)**

Symbol	Parameter / Condition		min.	max.	Units	Notes
t <sub>AOND</sub>	ODT turn-on delay		2	2	t <sub>CK</sub>	
t <sub>AON</sub>	ODT turn-on	-400 & -533	t <sub>AC</sub> (min)	t <sub>AC</sub> (max) + 1 ns	ns	20
		-667	t <sub>AC</sub> (min)	t <sub>AC</sub> (max) + 0.7 ns		
t <sub>AONPD</sub>	ODT turn-on (Power-Down Modes)		t <sub>AC</sub> (min) + 2 ns	2 t <sub>CK</sub> + t <sub>AC</sub> (max) + 1 ns	ns	
t <sub>AOFD</sub>	ODT turn-off delay		2.5	2.5	t <sub>CK</sub>	
t <sub>AOF</sub>	ODT turn-off		t <sub>AC</sub> (min)	t <sub>AC</sub> (max) + 0.6 ns	ns	21
t <sub>AOFPD</sub>	ODT turn-off (Power-Down Modes)		t <sub>AC</sub> (min) + 2 ns	2.5 t <sub>CK</sub> + t <sub>AC</sub> (max) + 1 ns	ns	
t <sub>ANPD</sub>	ODT to Power Down Mode Entry Latency		3	-	t <sub>CK</sub>	
t <sub>AXPD</sub>	ODT Power Down Exit Latency		8	-	t <sub>CK</sub>	

## 7.4 Notes for Electrical Characteristics & AC Timing

1. Timings are guaranteed with  $CK/\overline{CK}$  differential slew rate of 2.0 V/ns. For DQS signals timings are guaranteed with a differential slew rate of 2.0 V/ns in differential strobe mode and a slew rate of 1 V/ns in single ended mode. For other slew rates see Section 8 of this datasheet.
2. The  $CK / \overline{CK}$  input reference level (for timing reference to  $CK / \overline{CK}$ ) is the point at which  $CK$  and  $\overline{CK}$  cross. The  $DQS / \overline{DQS}$ ,  $RDQS / \overline{RDQS}$ , input reference level is the crosspoint when in differential strobe mode; The input reference level for signals other than  $CK/\overline{CK}$ ,  $DQS / \overline{DQS}$ ,  $RDQS / \overline{RDQS}$ ,  $tIS$ ,  $tiH$ ,  $tDS$ ,  $tDH$  is  $VREF$ . For  $tIS$ ,  $tiH$ ,  $tDS$ ,  $tDH$  input reference levels see section 8.3 of this datasheet
3. Inputs are not recognized as valid until  $VREF$  stabilizes. During the period before  $VREF$  stabilizes,  $CKE = 0.2 \times VDDQ$  is recognized as  $LOW$ .
4. The output timing reference voltage level is  $VTT$ . See section 8 for the reference load for timing measurements.
5. Min ( $tCL$ ,  $tCH$ ) refers to the smaller of the actual clock low time and the actual clock high time as provided to the device (i.e. this value can be greater than the minimum specification limits for  $tCL$  and  $tCH$ ).
6. For input frequency change during DRAM operation, see the 2.11 section of this datasheet.
7. For timing definition, slew rate and slew rate derating see Section 8.3
8. For timing definition, slew rate and slew rate derating see Section 8.3
9. The  $tHZ$ ,  $tRPST$  and  $tLZ$ ,  $tRPRE$  parameters are referenced to a specific voltage level, which specify when the device output is no longer driving ( $tHZ$ ,  $tRPST$ ), or begins driving ( $tLZ$ ,  $tRPRE$ ).  $tHZ$  and  $tLZ$  transitions occur in the same access time windows as valid data transitions. These parameters are verified by design and characterization, but not subject to production test.
10. The maximum limit for this parameter is not a device limit. The device operate with a greater value for this parameter, but system performance (bus turnaround) degrades accordingly.
11.  $tRAS(max)$  is calculated from the maximum amount of time a DDR2 device can operate without a Refresh command which is equal to  $9 \times tREFI$
12. A maximum of eight Auto-Refresh commands can be posted to any given DDR2 SDRAM device.
13. The  $tRCD$  timing parameter is valid for both activate command to read or write command with and without Auto-Precharge. Therefore a separate parameter  $tRAP$  for activate command to read or write command with Auto-Precharge is not necessary anymore.
14. For each of the terms, if not already an integer, round to the next highest integer.  $tCK$  refers to the application clock period.  $WR$  refers to the  $WR$  parameter stored in the MRS.
15.  $tWTR$  is at least two clocks independent of operation frequency.
16. User can choose two different active power-down modes for additional power saving via MRS address bit A12. In "standard active power-down mode" (MRS, A12 = "0") a fast power-down exit timing  $tXARD$  can be used. In "low active power-down mode" (MRS, A12 = "1") a slow power-down exit timing  $tXARDS$  has to be satisfied.
17. The clock frequency is allowed to change during self-refresh mode or precharge power-down mode. In case of clock frequency change during power-down, a specific procedure is required as describes in section 2.12.
18. Consists of data pin skew and output pattern effects, and p-channel to n-channel variation of the output drivers as well as output slew rate mis-match between  $DQS / \overline{DQS}$  and associated  $DQ$  in any given cycle.
19. The Auto-Refresh command interval has be reduced to 3.9  $\mu s$  when operating the DDR2 DRAM in a temperature range between 85°C and 95°C.
20. ODT turn on time min. is when the device leaves high impedance and ODT resistance begins to turn on. ODT turn on time max is when the ODT resistance is fully on. Both are measure from  $tAOND$ .
21. ODT turn off time min. is when the device starts to turn off ODT resistance. ODT turn off time max is when the bus is in high impedance. Both are measured from  $tAOFD$ .



## 8. Reference Loads, Setup & Hold Timing Definition and Slew Rate Derating

### 8.1 Reference Load for Timing Measurements

The figure represents the timing reference load used in defining the relevant timing parameters of the device. It is not intended to either a precise representation of the typical system environment nor a depiction of the actual load presented by a production tester. System designers should use IBIS or other simulation tools to correlate the timing reference load to a system environment. Manufacturers correlate to their production test conditions, generally a coaxial transmission line terminated at the tester electronics. This reference load is also used for output slew rate characterization.

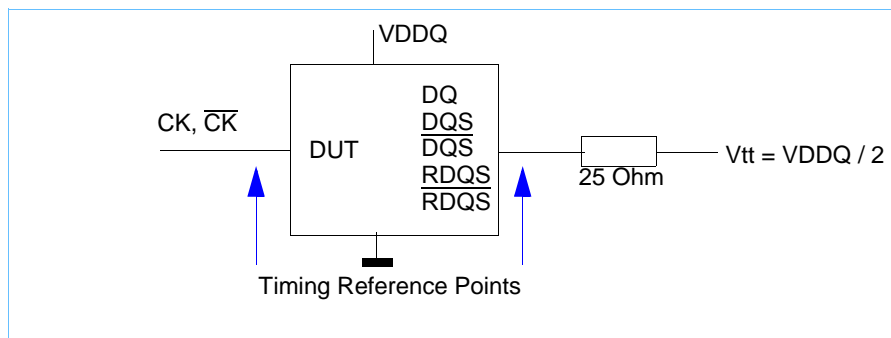

The output timing reference voltage level for single ended signals is the crosspoint with VTT. The output timing reference voltage level for differential signals is the crosspoint of the true (e.g. DQS) and the complement (e.g.  $\overline{DQS}$ ) signal.

### 8.2 Slewrate Measurements

#### 8.2.1 Output Slewrate

With the reference load for timing measurements output slew rate for falling and rising edges is measured between  $V_{TT} - 250\text{ mV}$  and  $V_{TT} + 250\text{ mV}$  for single ended signals. For differential signals (e.g. DQS /  $\overline{DQS}$ ) output slew rate is measured between  $DQS - \overline{DQS} = -500\text{ mV}$  and  $DQS - \overline{DQS} = +500\text{ mV}$ . Output slew rate is verified by design and characterisation, but not tested during production.

#### 8.2.2 Input Slewrate - Differential signals

Input slewrate for differential signals ( $CK / \overline{CK}$ ,  $DQS / \overline{DQS}$ ,  $RDQS / \overline{RDQS}$ ) for rising edges are measured from f.e.  $CK - \overline{CK} = -250\text{ mV}$  to  $CK - \overline{CK} = +500\text{ mV}$  and from  $CK - \overline{CK} = +250\text{ mV}$  to  $CK - \overline{CK} = -500\text{ mV}$  for falling edges.

#### 8.2.3 Input Slewrate - Single ended signals

Input slew rate for single ended signals (other than  $t_{is}$ ,  $t_{ih}$ ,  $t_{ds}$  and  $t_{dh}$ ) are measured from dc-level to ac-level:  $V_{REF} - 125\text{ mV}$  to  $V_{REF} + 250\text{ mV}$  for rising edges and from  $V_{REF} + 125\text{ mV}$  to  $V_{REF} - 250\text{ mV}$  for falling edges. For slew rate definition of the input and data setup and hold parameters see section 8.3 of this datasheet.

### 8.3 Input and Data Setup and Hold Time

#### 8.3.1 Timing Definition for Input Setup ( $t_{IS}$ ) and Hold Time ( $t_{IH}$ )

Address and control input setup time ( $t_{IS}$ ) is referenced from the input signal crossing at the  $V_{IH(ac)}$  level for a rising signal and  $V_{IL(ac)}$  for a falling signal applied to the device under test. Address and control input hold time ( $t_{IH}$ ) is referenced from the input signal crossing at the  $V_{IL(dc)}$  level for a rising signal and  $V_{IH(dc)}$  for a falling signal applied to the device under test..

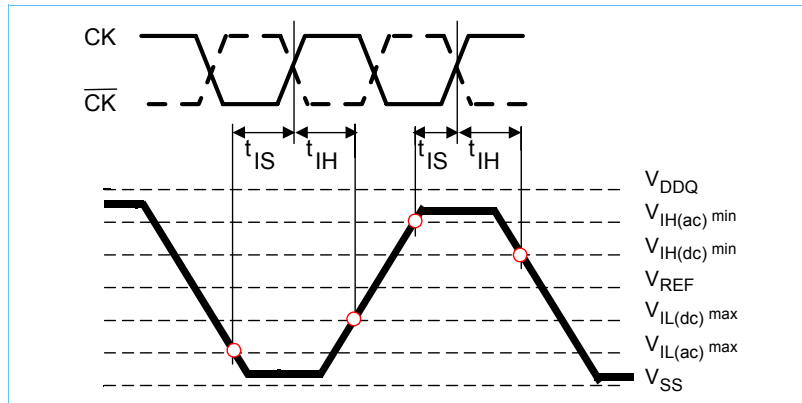

#### 8.3.2 Timing Definition for Data Setup ( $t_{DS}$ ) and Hold Time ( $t_{DH}$ )

Data input setup time ( $t_{DS}$ ) with *differential data strobe* enabled  $MR[bit10]=0$ , is referenced from the input signal crossing at the  $V_{IH(ac)}$  level to the differential data strobe crosspoint for a rising signal, and from the input signal crossing at the  $V_{IL(ac)}$  level to the differential data strobe crosspoint for a falling signal applied to the device under test.  $DQS/\overline{DQS}$  signals must be monotonic between  $V_{IL(dc)max}$  and  $V_{IH(dc)min}$ . Data input hold time ( $t_{DH}$ ) with differential data strobe enabled  $MR[bit10]=0$ , is referenced from the input signal crossing at the  $V_{IL(dc)}$  level to the differential data strobe crosspoint for a rising signal and  $V_{IH(dc)}$  to the differential data strobe crosspoint for a falling signal applied to the device under test.  $DQS/\overline{DQS}$  signals must be monotonic between  $V_{IL(dc)max}$  and  $V_{IH(dc)min}$ .

Data input setup time ( $t_{DS}$ ) with *single-ended data strobe* enabled  $MR[bit10]=1$ , is referenced from the input signal crossing at the  $V_{IH(ac)}$  level to the data strobe crossing  $V_{REF}$  for a rising signal, and from the input signal crossing at the  $V_{IL(ac)}$  level to the single-ended data strobe crossing  $V_{REF}$  for a falling signal applied to the device under test. Data input hold time ( $t_{DH}$ ) with single-ended data strobe enabled  $MR[bit10]=1$ , is referenced from the input signal crossing at the  $V_{IL(dc)}$  level to the single-ended data strobe crossing  $V_{REF}$  for a rising signal and  $V_{IH(dc)}$  to the single-ended data strobe crossing  $V_{REF}$  for a falling signal applied to the device under test.

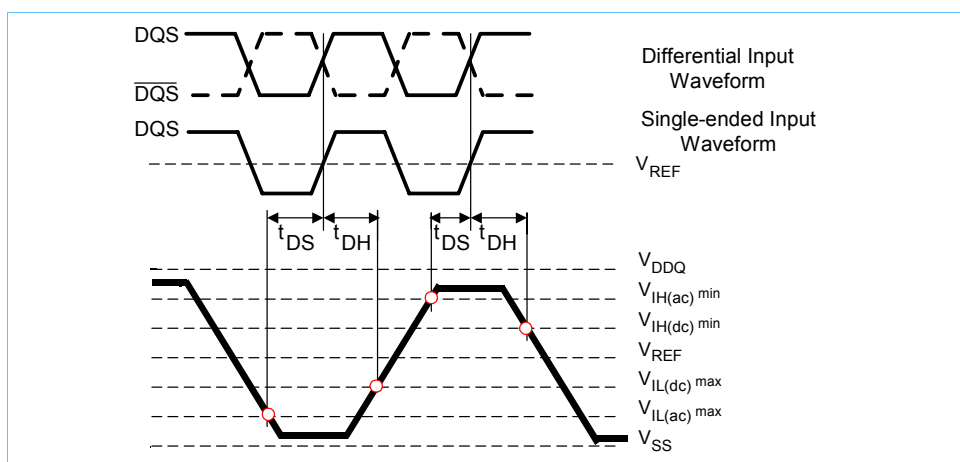

### 8.3.3 Slew Rate Definition for Input and Data Setup and Hold Times

Setup (tIS & tDS) nominal slew rate for a rising signal is defined as the slew rate between the last crossing of VREF(dc) and the first crossing of VIH(ac)min. Setup (tIS & tDS) nominal slew rate for a falling signal is defined as the slew rate between the last crossing of VREF(dc) and the first crossing of VIL(ac)max. If the actual signal is always earlier than the nominal slew rate line between shaded 'VREF(dc) to ac region', use nominal slew rate for derating value (see fig. A). If the actual signal is later than the nominal slew rate line anywhere between shaded 'VREF(dc) to ac region', the slew rate of a tangent line to the actual signal from the ac level to dc level is used for derating value.(see fig.B)

Hold (tIH & tDH) nominal slew rate for a rising signal is defined as the slew rate between the last crossing of VIL(dc)max and the first crossing of VREF(dc). Hold (tIH & tDH) nominal slew rate for a falling signal is defined as the slew rate between the last crossing of VIH(dc)min and the first crossing of VREF(dc). If the actual signal is always later than the nominal slew rate line between shaded 'dc to VREF region', use nominal slew rate for derating value (see fig. A). If the actual signal is earlier than the nominal slew rate line anywhere between shaded 'dc to VREF(dc) region', the slew rate of a tangent line to the actual signal from the dc level to VREF level is used for derating value (see fig.B).

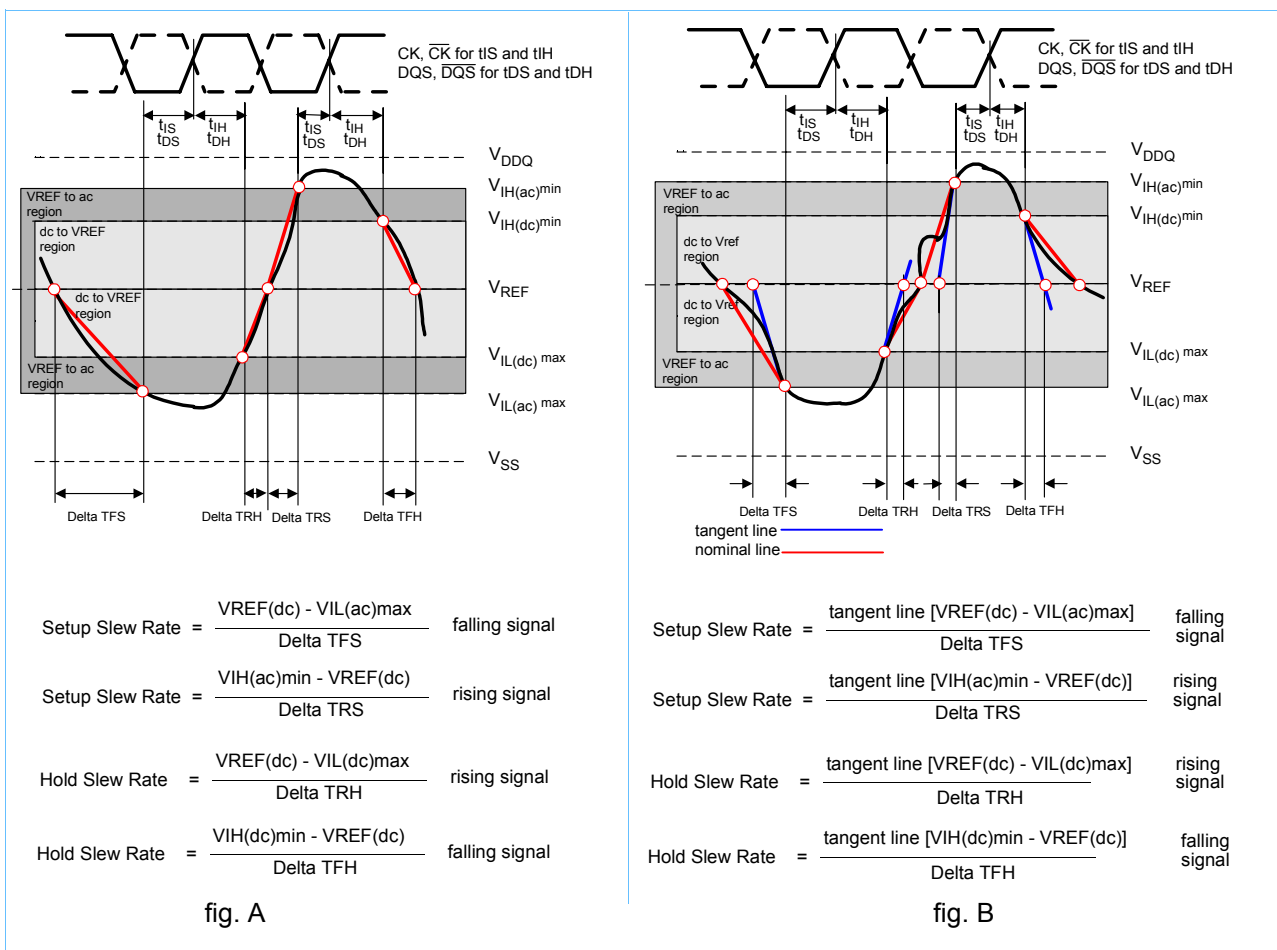

**8.3.4 Input Setup (tIS) and Hold (tIH) Time Derating Table**

		CK, $\overline{\text{CK}}$ Differential Slew Rate						Unit
		2.0 V/ns		1.5 V/ns		1.0 V/ns		
		$\Delta tIS$	$\Delta tIH$	$\Delta tIS$	$\Delta tIH$	$\Delta tIS$	$\Delta tIH$	
<b>Command / Address Slew rate</b>	4.0	+187	+94	+217	+124	+247	+154	ps
	3.5	+179	+89	+209	+119	+239	+149	ps
	3.0	+167	+83	+197	+113	+227	+143	ps
	2.5	+150	+75	+180	+105	+210	+135	ps
	2.0	+125	+45	+155	+75	+185	+105	ps
	1.5	+83	+21	+113	+51	+143	+81	ps
	1.0	0	0	+30	+30	+60	+60	ps
	0.9	-11	-14	+19	+16	+49	+46	ps
	0.8	-25	-31	+5	-1	+35	+29	ps
	0.7	-43	-54	-13	-24	+17	+6	ps
	0.6	-67	-83	-37	-53	-7	-23	ps
	0.5	-110	-125	-80	-95	-50	-65	ps
	0.4	-175	-188	-145	-158	-115	-128	ps
	0.3	-285	-292	-255	-262	-225	-232	ps
	0.25	-350	-375	-320	-345	-290	-315	ps
	0.2	-525	-500	-495	-470	-465	-440	ps
0.15	-800	-708	-770	-678	-740	-648	ps	
0.1	-1450	-1125	-1420	-1095	-1390	-1065	ps	

1. For all input signals the total tIS (input setup time) and tIH (input hold time) required is calculated by adding the individual datasheet value to the derating value listed in the previous table.
2. For slow slewrates the total setup time might be negativ (i.e. a valid input signal will not have reached VIH(ac) / VIL(ac) at the time of the rising clock) a valid input signal is still required to complete the transistion and reach VIH(ac) / VIL(ac). For slewrates in between the values listed in the next tables, the derating values may be obtained by linear interpolation. These values are not subject to production test. They are verified only by design and characterisation.

**8.3.5 Data Setup (tDS) and Hold Time (tDH) Derating Tablefor differential DQS /  $\overline{\text{DQS}}$**

		DQS, $\overline{\text{DQS}}$ Differential Slew Rate																		Unit	
		4.0 V/ns		3.0 V/ns		2.0 V/ns		1.8 V/ns		1.6 V/ns		1.4 V/ns		1.2 V/ns		1.0 V/ns		0.8 V/ns			
		$\Delta tDS$	$\Delta tDH$	$\Delta tDS$	$\Delta tDH$	$\Delta tDS$	$\Delta tDH$	$\Delta tDS$	$\Delta tDH$	$\Delta tDS$	$\Delta tDH$	$\Delta tDS$	$\Delta tDH$	$\Delta tDS$	$\Delta tDH$	$\Delta tDS$	$\Delta tDH$	$\Delta tDS$	$\Delta tDH$		
<b>DQ Slewrate (V/ns)</b>	2.0	+125	+45	+125	+45	+125	+45	-	-	-	-	-	-	-	-	-	-	-	-	ps	
	1.5	+83	+21	+83	+21	+83	+21	+95	+33	-	-	-	-	-	-	-	-	-	-	-	ps
	1.0	0	0	0	0	0	0	+12	+12	+24	+24	-	-	-	-	-	-	-	-	-	ps
	0.9	-	-	-11	-14	-11	-14	+1	-2	+13	+10	+25	+22	-	-	-	-	-	-	-	ps
	0.8	-	-	-	-	-25	-31	-13	-19	-1	-7	+11	+5	+23	+17	-	-	-	-	-	ps
	0.7	-	-	-	-	-	-	-31	-42	-19	-30	-7	-18	+5	-6	+17	+6	-	-	-	ps
	0.6	-	-	-	-	-	-	-	-	-43	-49	-31	-47	-19	-35	-7	-23	+5	-11	-	ps
	0.5	-	-	-	-	-	-	-	-	-	-	-74	-89	-62	-77	-50	-65	-38	-53	-	ps
	0.4	-	-	-	-	-	-	-	-	-	-	-	-	-127	-140	-115	-128	-103	-116	-	ps

1. For all input signals the total tDS (setup time) and tDH (hold time) required is calculated by adding the individual datasheet value to the derating value listed in the previous table.
2. For slow slewrates the total setup time might be negativ (i.e. a valid input signal will not have reached VIH(ac) / VIL(ac) at the time of the rising DQS) a valid input signal is still required to complete the transistion and reach VIH(ac) / VIL(ac). For slewrates in between the values listed in the next tables, the derating values may be obtained by linear interpolation. These values are not subject to production test. They are verified only by design and characterisation.

## 8.4 Overshoot and Undershoot Specification

### 8.4.1 AC Overshoot / Undershoot Specification for Address and Control Pins

Parameter	DDR2 -400	DDR2 -533	DDR2 -667	Units
Maximum peak amplitude allowed for overshoot area	0.9	0.9	0.9	V
Maximum peak amplitude allowed for undershoot area	0.9	0.9	0.9	V
Maximum overshoot area above VDD	0.75	0.56	0.45	V.ns
Maximum undershoot area below VSS	0.75	0.56	0.45	V.ns

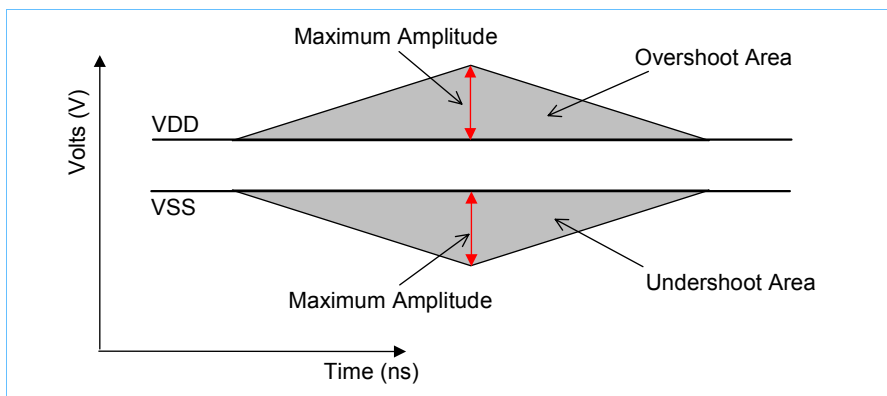

### 8.4.2 AC Overshoot / Undershoot Specification for Clock, Data, Strobe and Mask Pins

Parameter	DDR2 -400	DDR2 -533	DDR2 -667	Units
Maximum peak amplitude allowed for overshoot area	0.9	0.9	0.9	V
Maximum peak amplitude allowed for undershoot area	0.9	0.9	0.9	V
Maximum overshoot area above VDDQ	0.38	0.28	0.23	V.ns
Maximum undershoot area below VSSQ	0.38	0.28	0.23	V.ns

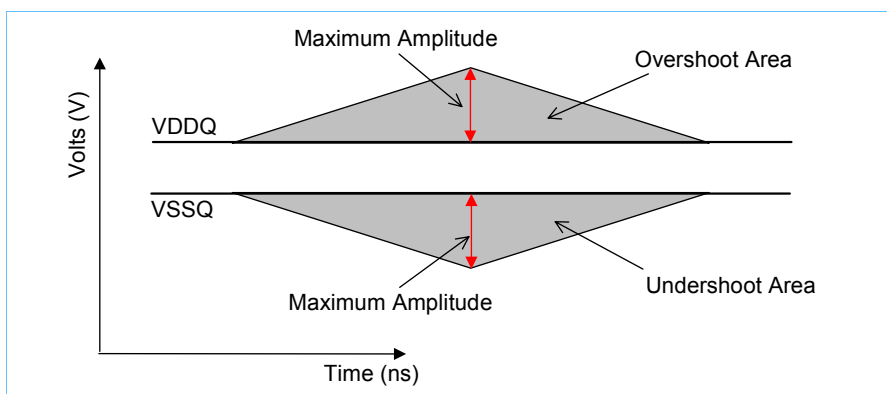

## 9. Package Dimensions

**60 balls FBGA-Package**  
 10,5 mm x 10,0 mm  
 MO-207 Variation DJ-z (x4,x8)

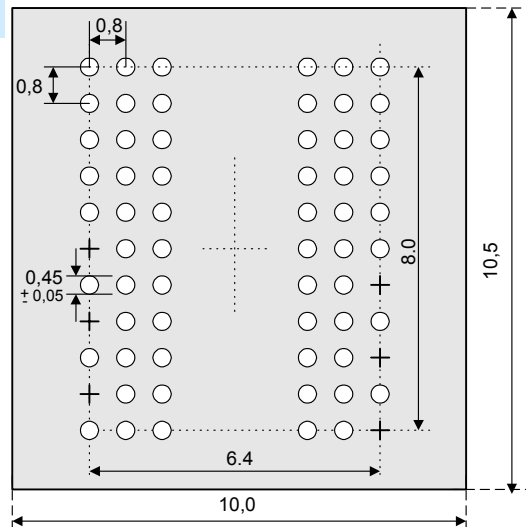

**TOP VIEW**  
 (see balls through package)

**84 balls FBGA-Package**  
 12,5 mm x 10,0 mm  
 MO-207 Variation DK-z (x16)

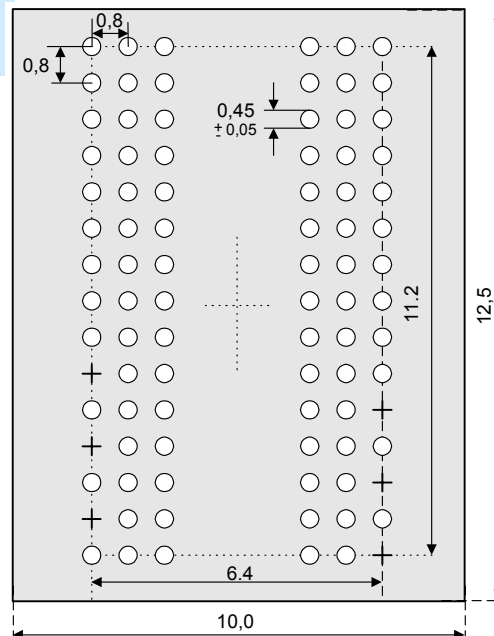

**TOP VIEW**  
 (see balls through package)

## 10. DDR2 Component Nomenclature

<div style="text-align: center;"> <table border="1"> <tr> <td style="width: 15px;">1</td> <td style="width: 15px;">2</td> <td style="width: 15px;">3</td> <td style="width: 15px;">4</td> <td style="width: 15px;">5</td> <td style="width: 15px;">6</td> <td style="width: 15px;">7</td> <td style="width: 15px;">8</td> <td style="width: 15px;">9</td> </tr> <tr> <td>Example :</td> <td>HYB</td> <td>18</td> <td>T</td> <td>256</td> <td>40</td> <td>0</td> <td>A</td> <td>C</td> <td>-5</td> </tr> </table> </div>						1	2	3	4	5	6	7	8	9	Example :	HYB	18	T	256	40	0	A	C	-5
1	2	3	4	5	6	7	8	9																
Example :	HYB	18	T	256	40	0	A	C	-5															
1	INFINEON Component Prefix	HYB for DRAM Components	6	Product Variations	0 = standard 2 = two dies in one package																			
2	Power Supply Voltage	18 = 1.8 V Power Supply	7	Die Revision	A = 1st Generation B = 2nd Generation C = 3rd Generation																			
3	DRAM Technology	T = DDR2	8	Package Type	C = BGA package F = BGA package (lead and halogen free)																			
4	Memory Density	256 = 256 Mb 512 = 512 Mb 1G = 1024 Mb 2G = 2048 Mb	9	Speed Grade	-5 = DDR2-400-333 -3.7 = DDR2-533-444 -3 = DDR2-667-444 -3S = DDR2-667-555																			
5	Memory Organisation	40 = x4, 4 data in/outputs 80 = x8, 8 data in/outputs 16 = x16, 16 data in/outputs																						

## **11. Content**

### **1. Description**

- 1.1 Ordering Information
- 1.2 Pin Description
- 1.3 DDR2 SDRAM Addressing
- 1.4 Package Pinouts
- 1.5 Input / Output Functional Description
- 1.6 Block Diagrams

### **2. Functional Description**

- 2.1 Simplified State Diagram
- 2.2 Basic Functionality
  - 2.2.1 Power-On and Initialization
  - 2.2.2 Programming the Mode Registers
  - 2.2.3 Mode Register Set (MRS)
  - 2.2.4 Extended Mode Register Set (EMRS(1))
  - 2.2.5 Extended Mode Register Set (EMRS(2))
  - 2.2.6 Extended Mode Register Set (EMRS(3))
- 2.3 Off-Chip Driver (OCD) Impedance Adjustment
- 2.4 ODT On-Die Active Termination
- 2.5 Bank Activate Command
- 2.6 Read and Write Command
  - 2.6.1 Posted CAS
  - 2.6.2 Burst Mode Operation
  - 2.6.3 Burst Read Operation
  - 2.6.4 Burst Write Operation
  - 2.6.5 Write Data Mask
  - 2.6.6 Burst Interruption
- 2.7 Precharge Command
  - 2.7.1 Burst Read Operation followed by a Precharge
  - 2.7.2 Burst Write Operation followed by a Precharge
- 2.8 Auto-Precharge Command
  - 2.8.1 Read with Auto-Precharge
  - 2.8.2 Write with Auto-Precharge
  - 2.8.3 Read or Write to Precharge Command Spacing Summary
  - 2.8.4 Concurrent Auto-Precharge
- 2.9 Refresh Commands
  - 2.9.1 Auto-Refresh Command
  - 2.9.2 Self-Refresh Command
- 2.10 Power-Down
- 2.11 Other Commands
  - 2.11.1 No Operation
  - 2.11.2 Deselect
- 2.12 Input Clock Frequency Change
- 2.13 Asynchronous CKE Low Event

### **3. Truth Tables**

- 3.1 Command Truth Table
- 3.2 Clock Enable (CKE) Truth Table
- 3.3 Data Mask (DM) Truth Table

### **4. Operating Conditions**

- 4.1 Absolute Maximum Ratings
- 4.2 DRAM Component Operating Temperature Range



## Content

### 5. AC & DC Operation Conditions

- 5.1 DC Operation Conditions
  - 5.1.1 Recommended DC Operation Conditions
  - 5.1.2 ODT DC Operation Conditions
  - 5.1.3 Input and Output Leakage Current
- 5.2 DC & AC Logic Input Levels
  - 5.2.1 Single-ended DC & AC Logic Input Levels)
  - 5.2.2 Single-ended AC Input Test Conditions
  - 5.2.3 Differential DC and AC Input and Output Logic Levels
- 5.3 Output Buffer Levels
  - 5.3.1 Output DC Current Drive
  - 5.3.2 Output AC Test Conditions
  - 5.3.4 Default Output V-I Characteristics
  - 5.3.5 Full Strength Pull-up Driver Characteristics
  - 5.3.6 Full Strength Pull-down Driver Characteristics
  - 5.3.7 Calibrated Output Driver V-I Characteristics
- 5.4 Input/Output Capacitances
- 5.5 Power & Ground Clamp V-I Characteristics

### 6. IDD Specifications

- 6.1 IDD Specifications
- 6.2 IDD Measurement Conditions
- 6.2 ODT current

### 7. AC Timing Specifications

- 7.1 Timing parameters by speed grade - DDR2-400 & DDR2-533
- 7.2 Timing parameters by speed grade - DDR2-667
- 7.3 ODT AC Electrical Characteristics and Operating Conditions
- 7.4 Notes for AC Timing Specifications

### 8. Reference Loads, Slew Rates and Slew Rate Derating

- 8.1 Reference Load for Timing Measurements
- 8.2 Output Slew Rate Measurements
- 8.3 Input and Data Setup and Hold Time
  - 8.3.1 Timing Definition for Input Setup and Hold Time
  - 8.3.2 Timing Definition for Data Setup and Hold Time
  - 8.3.3 Slew Rate Definition for Input and Data Setup and Hold Time
  - 8.3.4 Input Setup and Hold Time Derating Table
  - 8.3.5 Data Setup and Hold Time Derating Table
- 8.4 Overshoot and Undershoot Specification

### 9. Package Dimensions

### 10. DDR2 component nomenclature

