

## PROTECTION PRODUCTS

### Description

The SLV series of transient voltage suppressors are designed to protect low voltage, state-of-the-art CMOS semiconductors from transients caused by electrostatic discharge (ESD), cable discharge events (CDE), lightning and other induced voltage surges.

The devices are constructed using Semtech's proprietary EPD process technology. The EPD process provides low standoff voltages with significant reductions in leakage currents and capacitance over silicon-avalanche diode processes. The SLVU2.8-4 features integrated low capacitance compensation diodes that reduce the maximum capacitance to <8pF per line. This, combined with low leakage current, means signal integrity is preserved in high-speed applications such as 10/100 Ethernet.

The SLVU2.8-4 is in an SO-8 package and may be used to protect two high-speed line pairs. The "flow-thru" design minimizes trace inductance and reduces voltage overshoot associated with ESD events. The low clamping voltage of the SLVU2.8-4 minimizes the stress on the protected IC.

The SLV series TVS diodes will meet the surge requirements of IEC 61000-4-2, Level 4.

### Features

- ◆ 400 Watts peak pulse power ( $t_p = 8/20\mu s$ )
- ◆ Transient protection for high speed data lines to **IEC 61000-4-2 (ESD) 15kV (air), 8kV (contact)**  
**IEC 61000-4-4 (EFT) 40A ( $t_p = 5/50ns$ )**  
**IEC 61000-4-5 (Lightning) 24A ( $t_p = 8/20\mu s$ )**
- ◆ Protects two line pairs (four lines)
- ◆ Comprehensive pin out for easy board layout
- ◆ Low capacitance
- ◆ Low leakage current
- ◆ Low operating and clamping voltages
- ◆ Solid-state EPD TVS process technology

### Mechanical Characteristics

- ◆ JEDEC SO-8 package
- ◆ Molding compound flammability rating: UL 94V-0
- ◆ Marking : Part number, date code, logo
- ◆ Packaging : Tape and Reel per EIA 481

### Applications

- ◆ 10/100 Ethernet
- ◆ WAN/LAN Equipment
- ◆ Switching Systems
- ◆ Desktops, Servers, & Notebooks
- ◆ Instrumentation
- ◆ Base Stations
- ◆ Analog Inputs

### Circuit Diagram

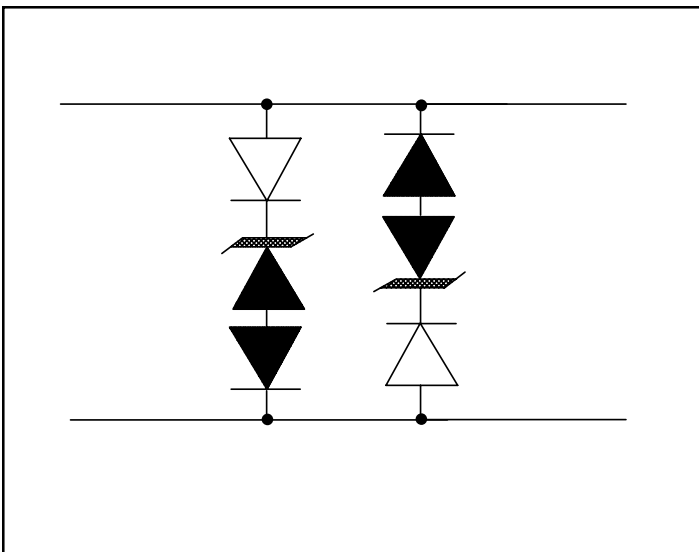

### Schematic & PIN Configuration

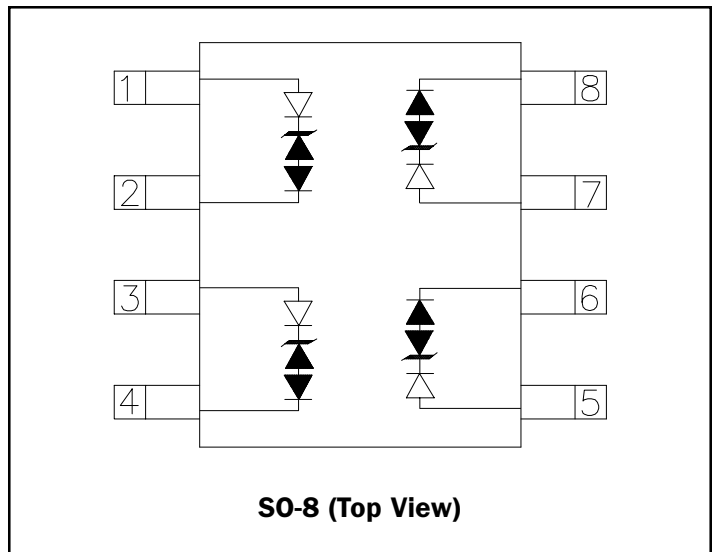

**PROTECTION PRODUCTS**
**Absolute Maximum Rating**

Rating	Symbol	Value	Units
Peak Pulse Power (tp = 8/20μs)	P <sub>pk</sub>	400	Watts
Peak Pulse Current (tp = 8/20μs)	I <sub>pp</sub>	24	A
ESD per IEC 61000-4-2 (Air) ESD per IEC 61000-4-2 (Contact)	V <sub>ESD</sub>	25 15	kV
Lead Soldering Temperature	T <sub>L</sub>	260 (10 seconds)	°C
Operating Temperature	T <sub>J</sub>	-55 to +125	°C
Storage Temperature	T <sub>STG</sub>	-55 to +150	°C

**Electrical Characteristics**

SLVU2.8-4						
Parameter	Symbol	Conditions	Minimum	Typical	Maximum	Units
Reverse Stand-Off Voltage	V <sub>RWM</sub>				2.8	V
Punch-Through Voltage	V <sub>PT</sub>	I <sub>PT</sub> = 2μA	3.0			V
Snap-Back Voltage	V <sub>SB</sub>	I <sub>SB</sub> = 50mA	2.8			V
Reverse Leakage Current	I <sub>R</sub>	V <sub>RWM</sub> = 2.8V, T=25°C (Each Line)			1	μA
Clamping Voltage	V <sub>C</sub>	I <sub>pp</sub> = 2A, tp = 8/20μs (Each Line)			5.5	V
Clamping Voltage	V <sub>C</sub>	I <sub>pp</sub> = 5A, tp = 8/20μs (Each Line)			8.5	V
Clamping Voltage	V <sub>C</sub>	I <sub>pp</sub> = 24A, tp = 8/20μs (Each Line)			15	V
Maximum Peak Pulse Current	I <sub>pp</sub>	tp = 8/20μs			24	A
Junction Capacitance	C <sub>J</sub>	V <sub>R</sub> = 0V, f = 1MHz (Each Line)		5	8	pF

PROTECTION PRODUCTS

Typical Characteristics

Non-Repetitive Peak Pulse Power vs. Pulse Time

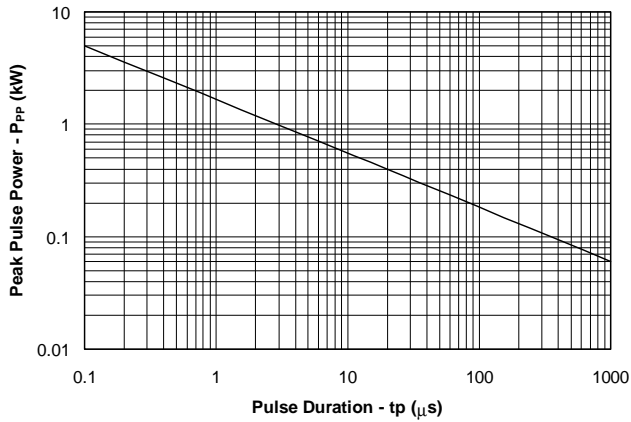

Power Derating Curve

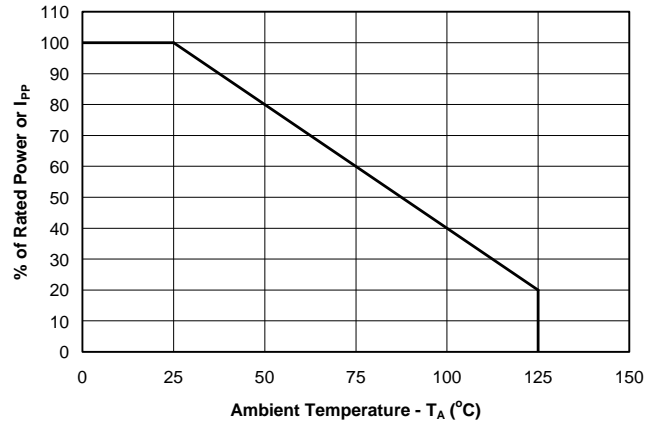

Pulse Waveform

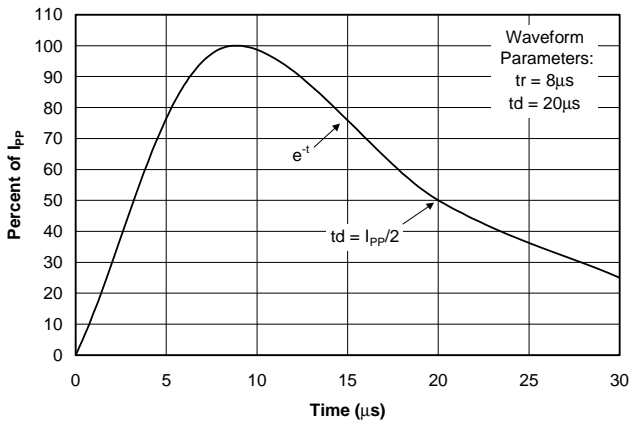

Clamping Voltage vs. Peak Pulse Current

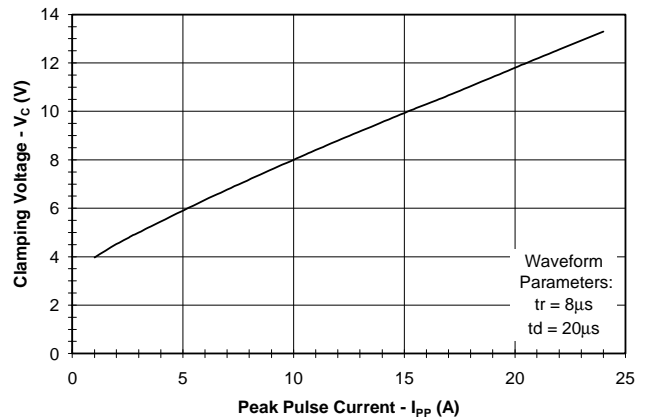

**PROTECTION PRODUCTS**

**Applications Information**

**Device Connection for Protection of Four Data Lines**

Electronic equipment is susceptible to transient disturbances from a variety of sources including: ESD to an open connector or interface, direct or nearby lightning strikes to cables and wires, and charged cables “hot plugged” into I/O ports. The SLVU2.8-4 is designed to protect sensitive components from damage and latch-up which may result from such transient events. The SLVU2.8-4 can be configured to protect two high-speed line pairs. The device is connected as follows:

**1. Protection of two high-speed line pairs:**

The SLVU2.8-4 is designed such that the data lines are routed through the device. The first line pair enters at pins 1 and 2 and exit at pins 8 and 7 respectively. The second line pair enters at pins 3 and 4 and exits at pins 6 and 5. The traces must be connected at the bottom of the device as shown.

**Circuit Board Layout Recommendations for Suppression of ESD.**

Good circuit board layout is critical for the suppression of ESD induced transients. The following guidelines are recommended:

- Place the SLVU2.8-4 near the input terminals or connectors to restrict transient coupling.
- Minimize the path length between the TVS and the protected line.
- Minimize all conductive loops including power and ground loops.
- The ESD transient return path to ground should be kept as short as possible.
- Never run critical signals near board edges.
- Use ground planes whenever possible.

**SLVU2.8-4 Circuit Diagram**

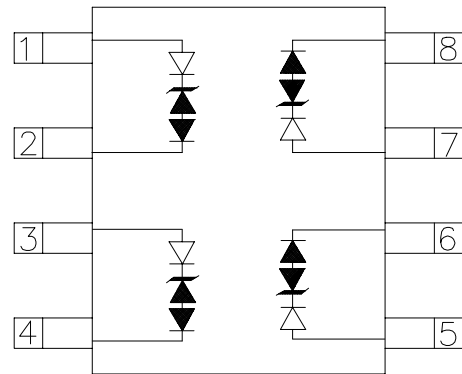

**Low Capacitance Protection of Two Differential Line Pairs**

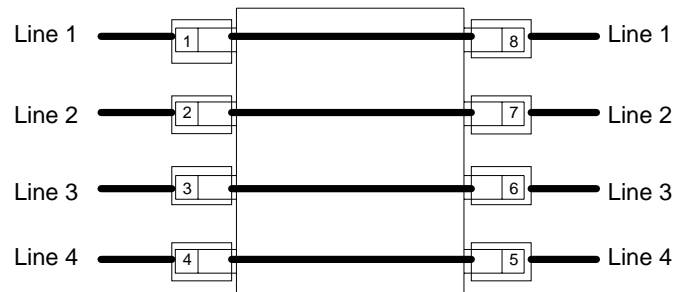

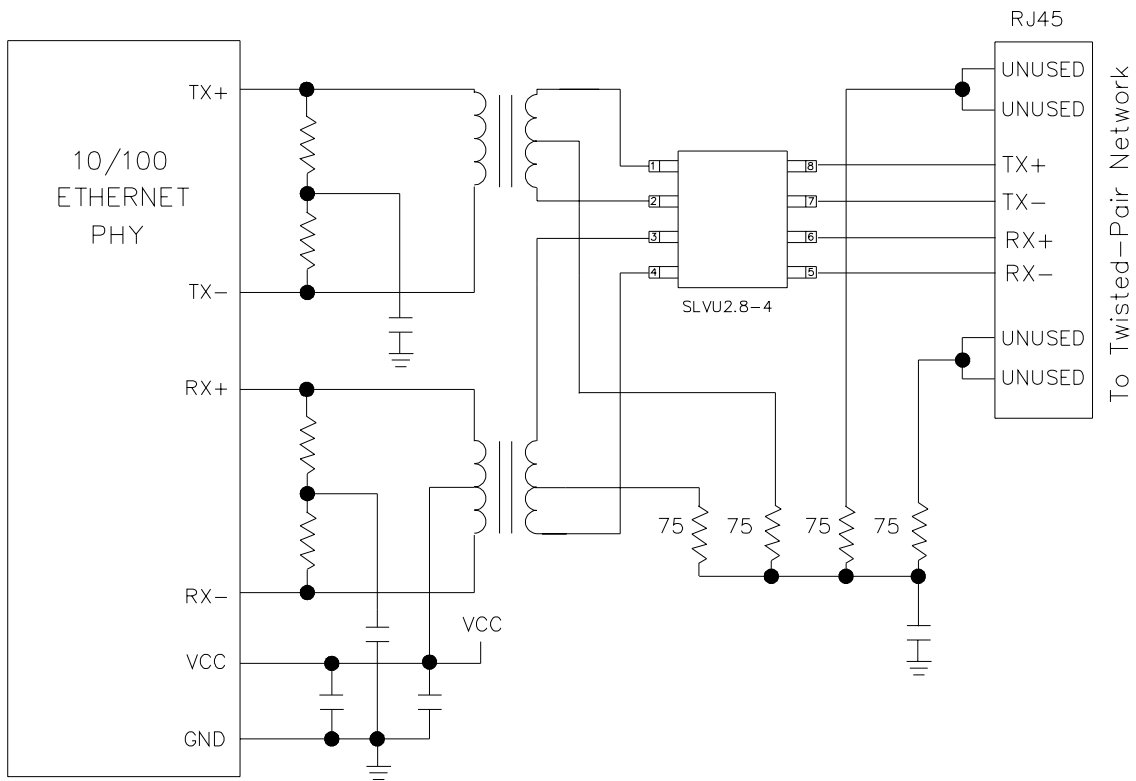
**PROTECTION PRODUCTS**
**Typical Applications**

**10/100 Ethernet Protection Circuit**

PROTECTION PRODUCTS

Applications Information (continued)

**EPD TVS™ Characteristics**

The SLVU2.8-4 is constructed using Semtech’s proprietary EPD technology. The structure of the EPD TVS is vastly different from the traditional pn-junction devices. At voltages below 5V, high leakage current and junction capacitance render conventional avalanche technology impractical for most applications. However, by utilizing the EPD technology, the SLVU2.8-4 can effectively operate at 2.8V while maintaining excellent electrical characteristics.

The EPD TVS employs a complex npnp structure in contrast to the pn structure normally found in traditional silicon-avalanche TVS diodes. The EPD mechanism is achieved by engineering the center region of the device such that the reverse biased junction does not avalanche, but will “punch-through” to a conducting state. This structure results in a device with superior dc electrical parameters at low voltages while maintaining the capability to absorb high transient currents.

The IV characteristic curve of the EPD device is shown in Figure 1. The device represents a high impedance to the circuit up to the working voltage ( $V_{RWM}$ ). During a transient event, the device will begin to conduct as it is biased in the reverse direction. When the punch-through voltage ( $V_{PT}$ ) is exceeded, the device enters a low impedance state, diverting the transient current away from the protected circuit. When the device is conducting current, it will exhibit a slight “snap-back” or negative resistance characteristic due to its structure. This must be considered when connecting the device to a power supply rail. To return to a non-conducting state, the current through the device must fall below the snap-back current (approximately < 50mA).

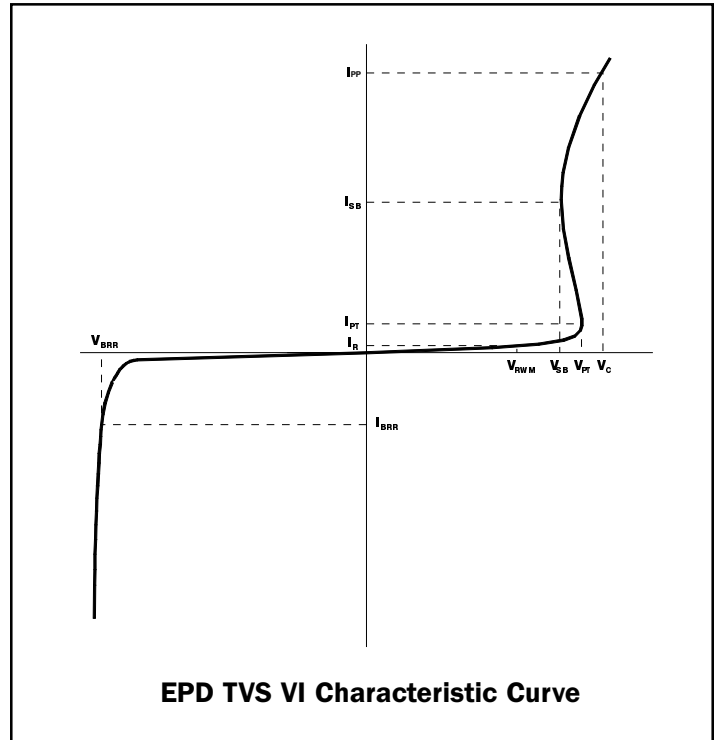

**EPD TVS VI Characteristic Curve**

PROTECTION PRODUCTS

Outline Drawing - S0-8

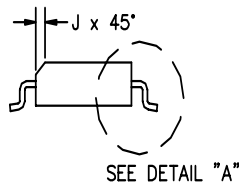
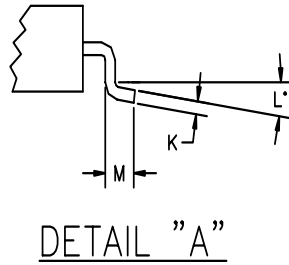
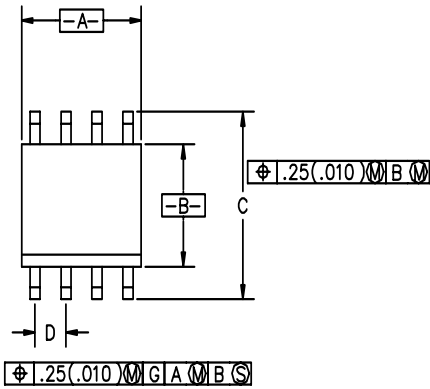

DIM <sup>N</sup>	INCHES		MM		NOTE
	MIN	MAX	MIN	MAX	
A	.188	.197	4.80	5.00	
B	.149	.158	3.80	4.00	
C	.228	.244	5.80	6.20	
D	.050	BSC	1.27	BSC	
E	.013	.020	0.33	0.51	
F	.004	.010	0.10	0.25	
H	.053	.069	1.35	1.75	
J	.011	.019	0.28	0.48	
K	.007	.010	.19	.25	
L	0°	8°	0°	8°	
M	.016	.050	0.40	1.27	

Land Pattern - S0-8

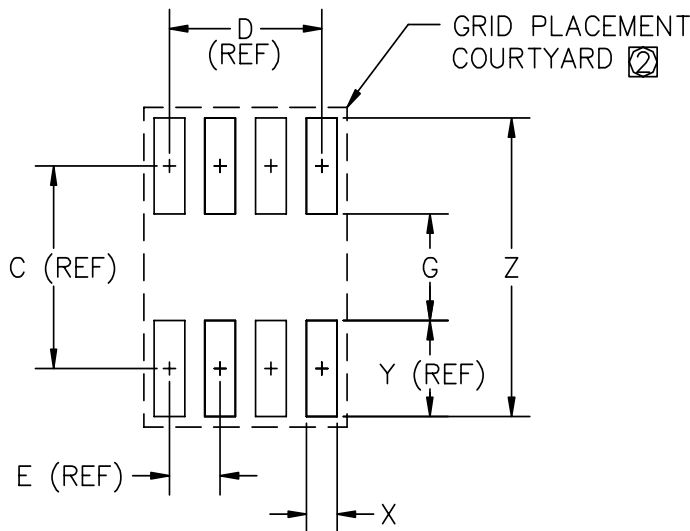

DIM <sup>N</sup>	INCHES		MM		NOTE
	MIN	MAX	MIN	MAX	
C	-	.19	-	5.00	-
D	-	.15	-	3.81	-
E	-	.05	-	1.27	-
G	.10	.11	2.60	2.80	-
X	.02	.03	.60	.80	-
Y	-	.09	-	2.40	-
Z	-	.29	7.20	7.40	-

② GRID PLACEMENT COURTYARD IS 12x16 ELEMENTS (6 mm X 8mm) IN ACCORDANCE WITH THE INTERNATIONAL GRID DETAILED IN IEC PUBLICATION 97.

① CONTROLLING DIMENSION: MILLIMETERS

**PROTECTION PRODUCTS****Ordering Information**

<b>Part Number</b>	<b>Working Voltage</b>	<b>Qty per Reel</b>	<b>Reel Size</b>
SLVU2.8-4.TB	2.8V	500	7 Inch
SLVU2.8-4.TE	2.8V	2,500	13 Inch

Note:

(1) No suffix indicates tube pack.

**Contact Information**

Semtech Corporation  
Protection Products Division  
652 Mitchell Rd., Newbury Park, CA 91320  
Phone: (805)498-2111 FAX (805)498-3804