

L to S BAND LOW NOISE AMPLIFIER  
N-CHANNEL HJ-FET

DESCRIPTION

NE34018 is a n-channel HJ-FET housed in MOLD package.

FEATURES

- Low noise figure  
NF = 0.6 dB TYP. at f = 2 GHz
- High associated gain  
Ga = 16 dB TYP. at f = 2 GHz
- Gate width:  $W_g = 400 \mu\text{m}$
- 4 pins super mini mold
- Tape & reel packaging only available

ORDERING INFORMATION

PART NUMBER	QUANTITY	PACKING STYLE
NE34018-T1	3 Kpcs/Reel.	Embossed tape 8 mm wide. Pin 3 (Source), Pin 4 (Drain) face to perforation side of the tape.
NE34018-T2	3 Kpcs/Reel.	Embossed tape 8 mm wide. Pin 1 (Source), Pin 2 (Gate) face to perforation side of the tape.

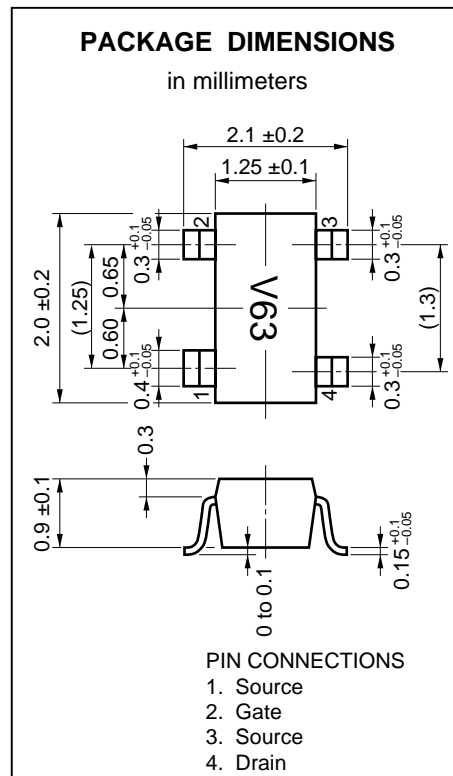

\* Please contact with responsible NEC person, if you require evaluation sample. Unit sample quantity shall be 50 pcs. (Part number for sample order: NE34018)

ABSOLUTE MAXIMUM RATINGS ( $T_A = 25^\circ\text{C}$ )

Drain to Source Voltage	$V_{DS}$	4.0	V
Gate to Source Voltage	$V_{GS}$	-3.0	V
Gate Current	$I_D$	$I_{DSS}$	mA
Total Power Dissipation	$P_{tot}$	150	mW
Channel Temperature	$T_{ch}$	125	$^\circ\text{C}$
Storage Temperature	$T_{stg}$	-65 to +125	$^\circ\text{C}$

**RECOMMENDED OPERATING CONDITION (T<sub>A</sub> = 25 °C)**

CHARACTERISTIC	SYMBOL	MIN.	TYP.	MAX.	UNIT
Drain to Source Voltage	V <sub>DS</sub>		2	3	V
Drain Current	I <sub>D</sub>		5	30	mA
Input Power	P <sub>in</sub>			+10	dBm

**ELECTRICAL CHARACTERISTICS (T<sub>A</sub> = 25 °C)**

CHARACTERISTIC	SYMBOL	MIN.	TYP.	MAX.	UNIT	TEST CONDITIONS
Gate to Source Leak Current	I <sub>GSO</sub>	–	0.5	10	μA	V <sub>GS</sub> = –3 V
Saturated Drain Current	I <sub>DSS</sub>	30		120	mA	V <sub>DS</sub> = 2 V, V <sub>GS</sub> = 0 V
Gate to Source Cut off Voltage	V <sub>GS(off)</sub>	–0.2	–0.8	–2.0	V	V <sub>DS</sub> = 2 V, I <sub>D</sub> = 100 μA
Transconductance	g <sub>m</sub>	30		–	mS	V <sub>DS</sub> = 2 V, I <sub>D</sub> = 5 mA
Noise Figure	NF		0.6	1.0	dB	V <sub>DS</sub> = 2 V, I <sub>D</sub> = 5 mA, f = 2 GHz
Associated Gain	G <sub>a</sub>	14	16		dB	
Power Gain	G <sub>s</sub>		18		dB	
Output Power at 1dB Gain Compression Point	P <sub>(1dB)</sub>		15		dBm	V <sub>DS</sub> = 3 V, I <sub>D</sub> = 30 mA (RF off) f = 2 GHz

**I<sub>DSS</sub> CLASSIFICATION**

RANK	I <sub>DSS</sub> (mA)	MARKING
63	30 to 65	V63
64	60 to 120	V64

TYPICAL CHARACTERISTICS ( $T_A = 25\text{ }^\circ\text{C}$ )

TOTAL POWER DISSIPATION vs. AMBIENT TEMPERATURE

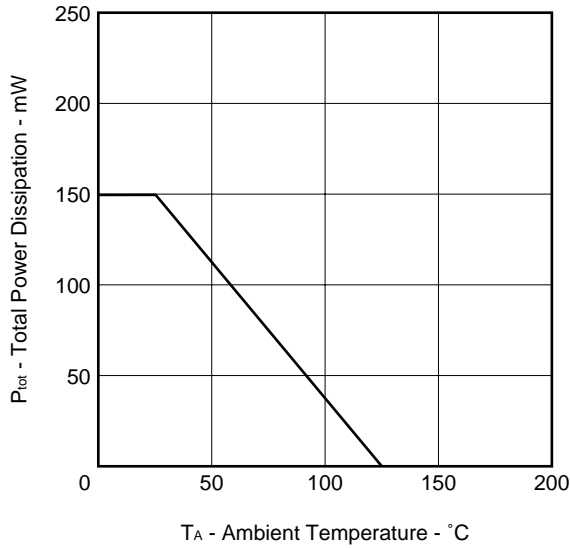

DRAIN CURRENT vs. DRAIN TO SOURCE VOLTAGE

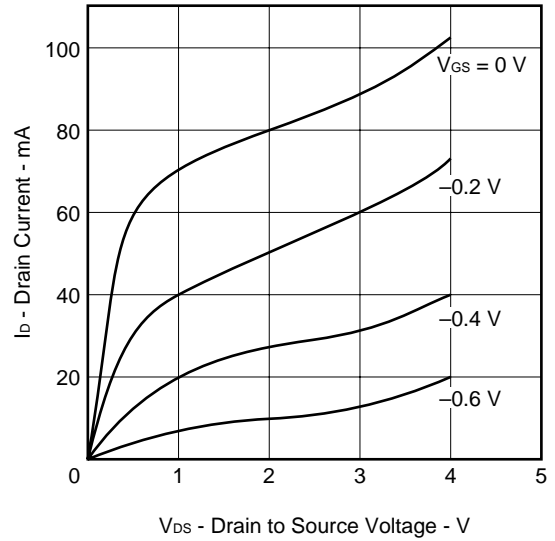

DRAIN CURRENT vs. GATE TO SOURCE VOLTAGE

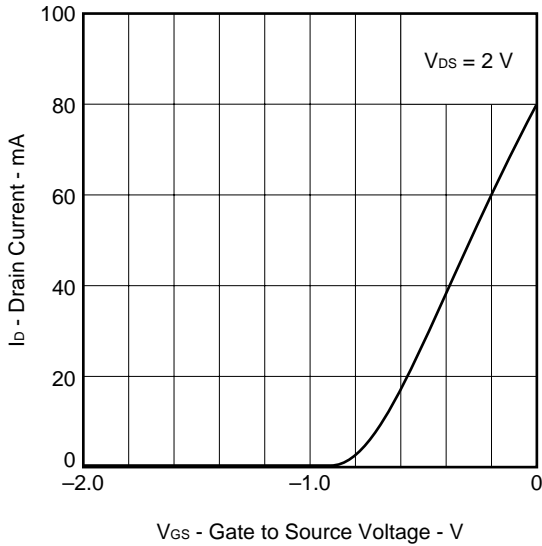

NOISE FIGURE, ASSOCIATED GAIN vs. DRAIN CURRENT

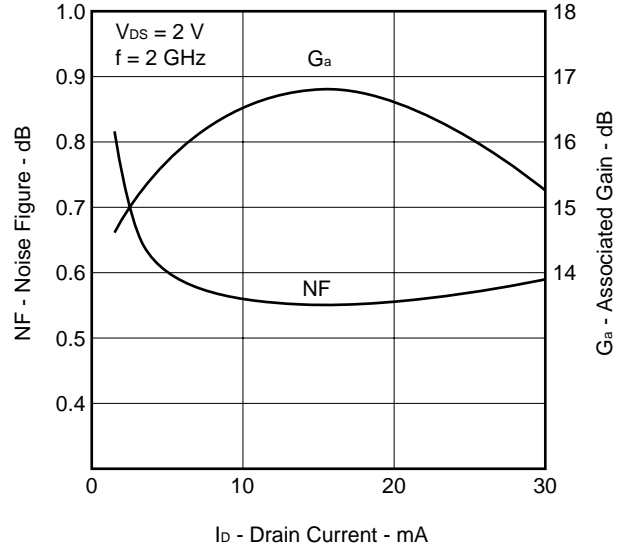

S-PARAMETER

MAG. AND ANG.

$V_{DS} = 2\text{ V}$ ,  $I_D = 5\text{ mA}$

FREQUENCY MHz	S <sub>11</sub>		S <sub>21</sub>		S <sub>12</sub>		S <sub>22</sub>	
	MAG.	ANG. (deg.)	MAG.	ANG. (deg.)	MAG.	ANG. (deg.)	MAG.	ANG. (deg.)
500	.997	-15.9	5.053	165.6	.020	82.6	.805	-9.0
600	.994	-19.1	5.070	162.8	.024	80.1	.801	-10.7
700	.989	-22.0	4.994	160.1	.027	79.0	.800	-12.3
800	.983	-25.1	4.992	157.4	.031	77.0	.798	-13.9
900	.978	-27.9	4.975	154.9	.035	75.1	.797	-15.4
1000	.972	-31.0	4.893	152.0	.039	73.7	.793	-17.0
1100	.954	-33.8	4.879	149.4	.042	71.8	.791	-18.4
1200	.960	-36.1	4.824	147.1	.045	71.0	.792	-19.6
1300	.951	-38.8	4.790	144.6	.048	69.9	.785	-20.9
1400	.945	-41.2	4.746	142.2	.050	68.9	.782	-22.2
1500	.934	-43.7	4.696	139.8	.054	68.2	.780	-23.4
1600	.926	-46.3	4.655	137.4	.056	65.4	.777	-24.4
1700	.914	-48.4	4.588	135.1	.058	65.7	.775	-25.5
1800	.901	-50.7	4.526	132.8	.061	63.9	.769	-26.3
1900	.887	-52.9	4.463	130.7	.063	62.7	.766	-27.3
2000	.807	-58.3	4.308	124.8	.064	58.5	.699	-27.7
2100	.787	-60.6	4.241	122.6	.066	57.1	.697	-28.6
2200	.775	-62.9	4.193	120.4	.067	56.1	.685	-29.8
2300	.755	-64.7	4.122	118.4	.070	55.8	.680	-30.2
2400	.745	-66.8	4.069	116.5	.070	54.8	.675	-31.1
2500	.732	-68.5	4.017	114.7	.072	55.0	.671	-31.9
2600	.720	-70.8	3.977	112.7	.074	54.5	.666	-32.5
2700	.706	-72.8	3.913	110.7	.075	53.1	.657	-33.6
2800	.691	-75.3	3.892	108.9	.077	53.1	.656	-34.1
2900	.677	-77.2	3.833	106.9	.078	51.7	.650	-34.8
3000	.657	-79.5	3.783	105.0	.080	51.5	.642	-35.6

**AMP. PARAMETERS**

V<sub>DS</sub> = 2 V, I<sub>D</sub> = 5 mA

FREQUENCY MHz	G <sub>Umax</sub> dB	G <sub>Amax</sub> dB	S <sub>21</sub>   <sup>2</sup> dB	S <sub>12</sub>   <sup>2</sup> dB	K	Delay ns	Mason's U dB	G <sub>1</sub> dB	G <sub>2</sub> dB
500	40.42		14.07	-34.10	.02	.078		21.81	4.53
600	37.65		14.10	-32.49	.04	.078		19.09	4.46
700	35.02		13.97	-31.28	.05	.074		16.61	4.44
800	33.18		13.97	-30.09	.07	.074		14.81	4.40
900	31.99		13.94	-29.02	.09	.070		13.68	4.37
1000	30.73		13.79	-28.27	.10	.079		12.63	4.31
1100	28.48		13.77	-27.56	.14	.072		10.45	4.26
1200	28.95		13.67	-26.99	.13	.065		11.01	4.28
1300	28.01		13.61	-26.40	.14	.068		10.24	4.16
1400	27.36		13.53	-25.95	.15	.068		9.73	4.11
1500	26.48		13.43	-25.35	.16	.065		8.97	4.08
1600	25.87		13.36	-25.02	.19	.067		8.48	4.02
1700	25.04		13.23	-24.73	.20	.064		7.82	3.98
1800	24.27		13.11	-24.35	.23	.065		7.27	3.88
1900	23.54		12.99	-23.99	.26	.057		6.72	3.83
2000	20.17		12.68	-23.88	.47	.164	27.008	4.57	2.92
2100	19.63		12.55	-23.67	.50	.063	25.640	4.20	2.89
2200	19.19		12.45	-23.48	.52	.059	25.263	3.99	2.75
2300	18.67		12.30	-23.16	.55	.056	24.878	3.67	2.70
2400	18.34		12.19	-23.05	.57	.054	24.607	3.51	2.64
2500	18.00		12.08	-22.91	.59	.049	25.175	3.33	2.59
2600	17.70		11.99	-22.65	.60	.056	25.565	3.17	2.54
2700	17.30		11.85	-22.46	.63	.055	24.387	3.00	2.45
2800	17.07		11.80	-22.24	.63	.050	25.422	2.82	2.45
2900	16.71		11.67	-22.10	.67	.057	24.032	2.66	2.38
3000	16.31		11.56	-21.89	.69	.053	23.850	2.45	2.30

S-PARAMETER

MAG. AND ANG.

$V_{DS} = 2\text{ V}$ ,  $I_D = 10\text{ mA}$

FREQUENCY MHz	S <sub>11</sub>		S <sub>21</sub>		S <sub>12</sub>		S <sub>22</sub>	
	MAG.	ANG. (deg.)	MAG.	ANG. (deg.)	MAG.	ANG. (deg.)	MAG.	ANG. (deg.)
500	.988	-18.2	7.217	163.2	.018	80.7	.722	-9.7
600	.982	-21.8	7.184	160.0	.022	79.7	.717	-11.6
700	.974	-25.0	7.070	156.9	.025	77.5	.717	-13.4
800	.964	-28.4	6.995	153.8	.029	77.4	.711	-15.0
900	.954	-31.5	6.928	150.8	.032	75.0	.710	-16.6
1000	.942	-34.7	6.797	147.9	.035	74.4	.705	-18.1
1100	.924	-37.8	6.707	144.9	.038	71.9	.702	-19.7
1200	.922	-40.4	6.607	142.3	.042	72.7	.700	-20.8
1300	.909	-43.2	6.506	139.5	.044	70.6	.694	-21.9
1400	.897	-45.8	6.387	136.8	.046	70.4	.690	-23.4
1500	.880	-48.4	6.286	134.4	.049	68.6	.688	-24.4
1600	.868	-50.9	6.179	131.7	.052	68.2	.683	-25.3
1700	.851	-53.2	6.055	129.3	.053	67.1	.680	-26.4
1800	.836	-55.3	5.937	126.9	.055	66.5	.675	-27.1
1900	.817	-57.6	5.829	124.7	.058	65.7	.671	-27.8
2000	.735	-63.0	5.570	119.4	.058	61.7	.604	-27.3
2100	.710	-65.4	5.453	117.0	.060	61.2	.600	-28.1
2200	.697	-67.6	5.354	114.8	.061	60.0	.590	-29.1
2300	.675	-69.4	5.242	112.8	.064	59.6	.586	-29.5
2400	.662	-71.5	5.148	110.9	.065	59.4	.580	-30.1
2500	.647	-73.0	5.057	109.0	.067	59.5	.577	-30.6
2600	.634	-75.2	4.977	107.1	.069	58.6	.573	-31.2
2700	.617	-77.3	4.880	105.1	.071	58.7	.567	-32.1
2800	.602	-79.5	4.819	103.4	.073	58.4	.567	-32.5
2900	.584	-81.5	4.734	101.4	.075	57.6	.559	-33.2
3000	.564	-83.6	4.640	99.5	.076	56.6	.553	-33.8

AMP. PARAMETERS

V<sub>DS</sub> = 2 V, I<sub>D</sub> = 10 mA

FREQUENCY MHz	G <sub>Umax</sub> dB	G <sub>Amax</sub> dB	S <sub>21</sub>   <sup>2</sup> dB	S <sub>12</sub>   <sup>2</sup> dB	K	Delay ns	Mason's U dB	G <sub>1</sub> dB	G <sub>2</sub> dB
500	36.72		17.17	-34.88	.08	.089		16.35	3.20
600	34.68		17.13	-33.03	.10	.089		14.42	3.14
700	33.00		16.99	-31.95	.13	.086		12.88	3.13
800	31.44		16.90	-30.71	.13	.087		11.48	3.06
900	30.33		16.81	-29.79	.16	.083		10.48	3.04
1000	29.14		16.65	-29.03	.18	.081		9.51	2.98
1100	27.83		16.53	-28.43	.22	.081		8.35	2.95
1200	27.55		16.40	-27.64	.21	.074		8.23	2.93
1300	26.71		16.27	-27.23	.24	.077		7.59	2.86
1400	25.99		16.11	-26.69	.25	.075		7.08	2.81
1500	25.23		15.97	-26.24	.29	.068		6.48	2.79
1600	24.63		15.82	-25.75	.30	.072		6.08	2.73
1700	23.92		15.64	-25.45	.33	.068		5.58	2.70
1800	23.33		15.47	-25.15	.36	.067		5.21	2.65
1900	22.70		15.31	-24.68	.38	.061		4.78	2.60
2000	20.26		14.92	-24.71	.60	.148	28.512	3.37	1.97
2100	19.72		14.73	-24.48	.64	.066	27.821	3.05	1.94
2200	19.32		14.57	-24.29	.67	.062	26.935	2.89	1.86
2300	18.85		14.39	-23.88	.69	.054	26.358	2.64	1.83
2400	18.52		14.23	-23.71	.71	.054	26.420	2.50	1.78
2500	18.19		14.08	-23.54	.73	.051	26.588	2.36	1.76
2600	17.90		13.94	-23.21	.74	.054	26.416	2.23	1.73
2700	17.53		13.77	-23.02	.76	.056	26.641	2.08	1.69
2800	17.29		13.66	-22.78	.77	.048	27.042	1.95	1.68
2900	16.94		13.50	-22.53	.80	.056	26.181	1.81	1.63
3000	16.58		13.33	-22.43	.83	.053	24.840	1.66	1.59

S-PARAMETER

MAG. AND ANG.

$V_{DS} = 2\text{ V}$ ,  $I_D = 20\text{ mA}$

FREQUENCY MHz	S <sub>11</sub>		S <sub>21</sub>		S <sub>12</sub>		S <sub>22</sub>	
	MAG.	ANG. (deg.)	MAG.	ANG. (deg.)	MAG.	ANG. (deg.)	MAG.	ANG. (deg.)
500	.978	-20.1	9.298	160.9	.017	82.7	.637	-10.0
600	.968	-23.9	9.160	157.3	.021	80.2	.635	-11.8
700	.954	-27.5	9.000	153.9	.023	79.8	.632	-13.7
800	.943	-31.1	8.848	150.5	.026	77.7	.627	-15.3
900	.929	-34.4	8.700	147.3	.029	76.6	.627	-16.8
1000	.913	-37.7	8.501	144.0	.032	74.7	.621	-18.0
1100	.891	-40.8	8.335	141.0	.035	74.7	.618	-19.6
1200	.884	-43.5	8.162	138.0	.037	74.3	.617	-20.5
1300	.865	-46.4	7.972	135.2	.040	74.2	.613	-21.7
1400	.849	-48.9	7.801	132.3	.042	71.9	.607	-23.0
1500	.830	-51.4	7.607	129.8	.045	71.7	.606	-24.0
1600	.815	-54.0	7.440	127.1	.047	71.1	.603	-24.7
1700	.793	-56.3	7.247	124.7	.049	70.0	.599	-25.6
1800	.775	-58.3	7.074	122.2	.051	69.4	.598	-26.2
1900	.754	-60.4	6.913	119.9	.053	68.8	.593	-26.8
2000	.674	-65.8	6.573	115.0	.053	66.1	.528	-25.1
2100	.648	-68.1	6.417	112.7	.056	65.5	.526	-25.7
2200	.632	-70.2	6.265	110.5	.057	64.5	.516	-26.7
2300	.610	-71.9	6.113	108.6	.059	64.6	.515	-26.7
2400	.596	-73.7	5.976	106.7	.061	64.6	.510	-27.3
2500	.579	-75.2	5.849	105.0	.063	65.0	.509	-27.8
2600	.566	-77.1	5.727	103.1	.065	63.8	.507	-28.2
2700	.548	-79.3	5.610	101.1	.068	64.3	.502	-29.1
2800	.532	-81.2	5.499	99.4	.069	63.3	.502	-29.4
2900	.515	-83.0	5.399	97.5	.071	64.1	.498	-30.0
3000	.496	-84.8	5.272	95.7	.073	62.4	.493	-30.4



**AMP. PARAMETERS**

V<sub>DS</sub> = 2 V, I<sub>D</sub> = 20 mA

FREQUENCY MHz	G <sub>Umax</sub> dB	G <sub>Amax</sub> dB	S <sub>21</sub>   <sup>2</sup> dB	S <sub>12</sub>   <sup>2</sup> dB	K	Delay ns	Mason's U dB	G1 dB	G2 dB
500	35.28		19.37	-35.33	.12	.098		13.65	2.26
600	33.54		19.24	-33.71	.16	.098		12.07	2.24
700	31.81		19.09	-32.71	.18	.097		10.51	2.22
800	30.66		18.94	-31.61	.21	.094		9.55	2.17
900	29.62		18.79	-30.78	.24	.088		8.66	2.17
1000	28.49		18.59	-29.78	.28	.092		7.78	2.12
1100	27.38		18.42	-29.14	.31	.085		6.86	2.09
1200	26.91		18.24	-28.63	.32	.082		6.59	2.08
1300	26.08		18.03	-28.04	.34	.079		6.00	2.05
1400	25.38		17.84	-27.49	.38	.079		5.53	2.00
1500	24.70		17.62	-26.88	.40	.071		5.08	1.99
1600	24.13		17.43	-26.49	.42	.073		4.74	1.97
1700	23.43		17.20	-26.16	.46	.068		4.30	1.93
1800	22.90		16.99	-25.88	.49	.070		3.98	1.92
1900	22.33		16.79	-25.46	.52	.062		3.66	1.88
2000	20.40		16.35	-25.44	.72	.137	29.694	2.63	1.42
2100	19.92		16.15	-25.02	.75	.064	28.981	2.37	1.41
2200	19.50		15.94	-24.90	.79	.062	27.785	2.21	1.35
2300	19.08		15.72	-24.53	.81	.052	27.569	2.02	1.34
2400	18.74		15.53	-24.25	.82	.053	27.816	1.91	1.31
2500	18.41		15.34	-23.96	.84	.048	28.156	1.77	1.30
2600	18.13		15.16	-23.71	.85	.053	27.486	1.68	1.29
2700	17.79		14.98	-23.29	.86	.053	28.589	1.55	1.26
2800	17.51		14.80	-23.18	.88	.047	27.386	1.44	1.26
2900	17.22		14.65	-22.93	.89	.054	28.295	1.34	1.24
3000	16.88		14.44	-22.71	.92	.050	26.323	1.22	1.21

**S-PARAMETERS**

MAG. AND ANG.

$V_{DS} = 3\text{ V}$ ,  $I_D = 5\text{ mA}$

FREQUENCY MHz	S <sub>11</sub>		S <sub>21</sub>		S <sub>12</sub>		S <sub>22</sub>	
	MAG.	ANG. (deg.)	MAG.	ANG. (deg.)	MAG.	ANG. (deg.)	MAG.	ANG. (deg.)
500	.991	-15.2	5.038	165.1	.020	79.3	.817	-9.8
600	.984	-18.1	5.040	162.2	.024	79.0	.812	-11.7
700	.982	-20.8	4.984	159.4	.027	76.7	.809	-13.6
800	.973	-23.8	4.958	156.6	.031	77.2	.807	-15.2
900	.970	-26.6	4.958	154.1	.034	74.4	.806	-16.8
1000	.964	-29.0	4.892	151.4	.038	73.4	.803	-18.6
1100	.944	-32.0	4.850	148.6	.040	70.8	.797	-20.1
1200	.947	-34.2	4.791	146.2	.044	70.3	.794	-21.5
1300	.938	-36.7	4.764	143.8	.048	69.6	.791	-23.1
1400	.929	-38.9	4.722	141.4	.050	68.9	.788	-24.3
1500	.920	-41.3	4.675	139.0	.052	67.2	.789	-25.7
1600	.911	-43.6	4.640	136.6	.056	66.5	.786	-27.2
1700	.901	-45.7	4.579	134.4	.058	65.1	.780	-28.3
1800	.890	-47.9	4.527	132.2	.061	64.1	.778	-29.4
1900	.878	-49.8	4.473	130.0	.063	62.9	.775	-30.5
2000	.815	-57.5	4.306	123.9	.063	58.4	.687	-29.1

**AMP. PARAMETERS**

FREQUENCY MHz	G <sub>Umax</sub> dB	G <sub>Amax</sub> dB	$ S_{21} ^2$ dB	$ S_{12} ^2$ dB	K	Delay ns	Mason's U dB	G <sub>1</sub> dB	G <sub>2</sub> dB
500	36.20		14.05	-34.16	.09	.080	39.523	17.38	4.78
600	33.77		14.05	-32.46	.09	.080		15.04	4.69
700	32.94		13.95	-31.29	.11	.077		14.37	4.62
800	31.24		13.91	-30.13	.10	.077		12.75	4.58
900	30.67		13.91	-29.27	.12	.071		12.22	4.55
1000	29.74		13.79	-28.52	.13	.074		11.46	4.49
1100	27.71		13.72	-27.86	.18	.077		9.61	4.38
1200	27.80		13.61	-27.10	.17	.066		9.87	4.32
1300	27.04		13.56	-26.43	.17	.069		9.22	4.26
1400	26.34		13.48	-26.01	.18	.066		8.64	4.22
1500	25.76		13.40	-25.69	.20	.066		8.12	4.24
1600	25.18		13.33	-25.10	.21	.067		7.68	4.18
1700	24.52		13.21	-24.80	.23	.061		7.24	4.07
1800	24.00		13.12	-24.36	.24	.061		6.84	4.05
1900	23.40		13.01	-24.05	.26	.062		6.41	3.99
2000	20.18		12.68	-23.97	.47	.169	27.557	4.73	2.77

**S-PARAMETERS**

MAG. AND ANG.

V<sub>DS</sub> = 3 V, I<sub>D</sub> = 10 mA

FREQUENCY MHz	S <sub>11</sub>		S <sub>21</sub>		S <sub>12</sub>		S <sub>22</sub>	
	MAG.	ANG. (deg.)	MAG.	ANG. (deg.)	MAG.	ANG. (deg.)	MAG.	ANG. (deg.)
500	.982	-17.5	7.163	162.7	.019	82.5	.736	-10.5
600	.973	-20.9	7.082	159.4	.022	79.5	.732	-12.4
700	.965	-24.0	7.001	156.2	.025	76.7	.729	-14.4
800	.953	-27.2	6.905	153.1	.028	75.6	.725	-16.2
900	.944	-30.3	6.849	150.2	.032	74.8	.720	-17.8
1000	.934	-33.0	6.738	147.3	.035	73.4	.717	-19.5
1100	.913	-36.3	6.624	144.1	.037	72.4	.713	-21.2
1200	.909	-38.6	6.514	141.6	.040	70.8	.708	-22.5
1300	.894	-41.3	6.415	138.7	.043	71.0	.706	-24.0
1400	.882	-43.7	6.323	136.2	.046	69.7	.702	-25.2
1500	.866	-46.2	6.219	133.6	.048	67.6	.700	-26.5
1600	.853	-48.5	6.123	131.0	.050	67.0	.697	-27.9
1700	.837	-50.6	6.004	128.8	.052	67.2	.692	-29.0
1800	.823	-52.8	5.897	126.4	.055	66.5	.689	-29.9
1900	.808	-54.7	5.800	124.1	.057	65.4	.685	-31.0
2000	.747	-62.5	5.514	118.6	.058	61.2	.593	-28.2

**AMP. PARAMETERS**

FREQUENCY MHz	G <sub>Umax</sub> dB	G <sub>Amax</sub> dB	S <sub>21</sub>   <sup>2</sup> dB	S <sub>12</sub>   <sup>2</sup> dB	K	Delay ns	Mason's U dB	G <sub>1</sub> dB	G <sub>2</sub> dB
500	35.08		17.10	-34.56	.09	.093		14.59	3.38
600	33.03		17.00	-33.28	.13	.093		12.69	3.34
700	31.88		16.90	-32.21	.16	.088		11.69	3.29
800	30.40		16.78	-30.97	.18	.086		10.38	3.24
900	29.55		16.71	-29.89	.19	.081		9.66	3.18
1000	28.64		16.57	-29.23	.21	.082		8.93	3.14
1100	27.29		16.42	-28.63	.24	.088		7.79	3.08
1200	26.89		16.28	-27.89	.26	.070		7.59	3.02
1300	26.11		16.14	-27.29	.27	.080		6.97	3.00
1400	25.51		16.02	-26.83	.29	.068		6.53	2.95
1500	24.82		15.87	-26.32	.32	.074		6.02	2.92
1600	24.28		15.74	-25.98	.34	.072		5.65	2.89
1700	23.64		15.57	-25.60	.35	.062		5.25	2.83
1800	23.12		15.41	-25.23	.37	.066		4.91	2.80
1900	22.61		15.27	-24.82	.39	.064		4.59	2.75
2000	20.25		14.83	-24.80	.61	.152	28.504	3.55	1.88

**S-PARAMETERS**

MAG. AND ANG.

$V_{DS} = 3\text{ V}$ ,  $I_D = 30\text{ mA}$

FREQUENCY MHz	S <sub>11</sub>		S <sub>21</sub>		S <sub>12</sub>		S <sub>22</sub>	
	MAG.	ANG. (deg.)	MAG.	ANG. (deg.)	MAG.	ANG. (deg.)	MAG.	ANG. (deg.)
500	.974	-20.9	10.260	159.9	.016	82.5	.625	-9.7
600	.961	-24.8	10.103	156.1	.018	80.4	.620	-11.5
700	.947	-28.5	9.901	152.5	.022	79.9	.618	-13.3
800	.931	-32.2	9.688	149.1	.025	78.7	.614	-14.8
900	.915	-35.5	9.505	145.6	.028	76.8	.614	-16.2
1000	.894	-39.0	9.260	142.3	.030	76.4	.608	-17.7
1100	.875	-41.9	9.057	139.2	.032	76.3	.607	-18.9
1200	.863	-44.7	8.850	136.2	.035	74.8	.605	-19.8
1300	.843	-47.5	8.618	133.3	.036	73.8	.599	-20.9
1400	.825	-50.1	8.399	130.4	.039	73.5	.595	-21.9
1500	.806	-52.5	8.182	127.9	.042	72.1	.594	-22.8
1600	.788	-55.2	7.980	125.2	.044	72.6	.593	-23.6
1700	.768	-57.1	7.770	122.6	.046	71.8	.590	-24.4
1800	.747	-59.2	7.550	120.2	.048	72.5	.588	-24.9
1900	.726	-61.2	7.356	118.1	.050	71.2	.586	-25.5
2000	.646	-66.6	6.989	113.2	.050	67.4	.521	-23.5

**AMP. PARAMETERS**

FREQUENCY MHz	GU <sub>max</sub> dB	GA <sub>max</sub> dB	$ S_{21} ^2$ dB	$ S_{12} ^2$ dB	K	Delay ns	Mason's U dB	G1 dB	G2 dB
500	35.31		20.22	-36.03	.15	.103		12.94	2.15
600	33.31		20.09	-34.85	.19	.103		11.12	2.11
700	31.84		19.91	-33.23	.21	.100		9.83	2.09
800	30.56		19.72	-32.13	.25	.097		8.77	2.06
900	29.50		19.56	-31.12	.28	.095		7.88	2.05
1000	28.32		19.33	-30.59	.32	.093		6.98	2.01
1100	27.43		19.14	-29.81	.34	.086		6.29	2.00
1200	26.85		18.94	-29.05	.37	.085		5.93	1.98
1300	26.02		18.71	-28.76	.40	.079		5.38	1.93
1400	25.34		18.48	-28.20	.43	.081		4.96	1.90
1500	24.70		18.26	-27.62	.46	.070		4.55	1.89
1600	24.14		18.04	-27.03	.47	.073		4.21	1.88
1700	23.53		17.81	-26.74	.51	.071		3.87	1.86
1800	22.94		17.56	-26.38	.53	.068		3.54	1.84
1900	22.41		17.33	-26.03	.56	.059		3.25	1.82
2000	20.61		16.89	-25.99	.78	.135	29.365	2.35	1.37

**NOISE PARAMETER**

V<sub>DS</sub> = 2 V, I<sub>D</sub> = 5 mA

Freq (GHz)	NF <sub>min</sub> (dB)	G <sub>a</sub> (dB)	Γ <sub>opt</sub>		R <sub>n</sub> /50
			MAG.	ANG. (deg.)	
0.9	0.51	21.2	0.69	15	0.26
1.0	0.52	20.8	0.68	17	0.25
1.5	0.57	18.2	0.63	25	0.24
2.0	0.61	16.2	0.61	35	0.23
2.5	0.62	14.4	0.56	46	0.21
3.0	0.65	13.3	0.44	59	0.17

V<sub>DS</sub> = 2 V, I<sub>D</sub> = 10 mA

Freq (GHz)	NF <sub>min</sub> (dB)	G <sub>a</sub> (dB)	Γ <sub>opt</sub>		R <sub>n</sub> /50
			MAG.	ANG. (deg.)	
0.9	0.43	22.0	0.62	13	0.20
1.0	0.44	21.6	0.61	14	0.20
1.5	0.49	19.0	0.58	23	0.19
2.0	0.52	16.5	0.57	34	0.18
2.5	0.54	14.9	0.52	45	0.17
3.0	0.57	13.8	0.36	57	0.13

V<sub>DS</sub> = 3 V, I<sub>D</sub> = 10 mA

Freq (GHz)	NF <sub>min</sub> (dB)	G <sub>a</sub> (dB)	Γ <sub>opt</sub>		R <sub>n</sub> /50
			MAG.	ANG. (deg.)	
0.9	0.43	22.2	0.61	11	0.21
1.0	0.44	21.8	0.60	13	0.20
1.5	0.49	19.2	0.57	22	0.20
2.0	0.52	16.7	0.57	33	0.19
2.5	0.54	15.1	0.52	45	0.18
3.0	0.57	14.0	0.37	58	0.14

**RECOMMENDED SOLDERING CONDITIONS**

The following conditions (see table below) must be met when soldering this product.

Please consult with our sales offices in case other soldering process is used, or in case soldering is done under different conditions.

**<TYPES OF SURFACE MOUNT DEVICE>**

For more details, refer to our document "SEMICONDUCTOR DEVICE MOUNTING TECHNOLOGY MANUAL" (C10535E).

Soldering process	Soldering conditions	Symbol
VPS	Package peak temperature: 215 °C, Time: 40 seconds MAX. (200 °C MIN.), Number of times: 3, Number of days: not limited*	VP15-00-3
Wave soldering	Soldering bath temperature: 260 °C MAX., Time: 10 seconds MAX., Number of times: 1, Number of days: not limited*	WS60-00-1
Infrared ray reflow	Peak package's surface temperature: 230 °C below, Reflow time: 30 seconds or below (210 °C or higher), Number of reflow process: 3, Exposure limit*: None	IR30-00-3
Partial heating method	Terminal temperature: 230 °C or below, Flow time: 10 seconds or below, Exposure limit*: None	

\* Exposure limit before soldering after dry-pack package is opened.  
Storage conditions: 25 °C and relative humidity at 65 % or less.

**Note** Do not apply more than a single process at once, except for "Partial heating method".

**PRECAUTION** Avoid high static voltage and electric fields, because this device is Hetero Junction field effect transistor with shottky barrier gate.

[MEMO]

## Caution

**The Great Care must be taken in dealing with the devices in this guide.**

**The reason is that the material of the devices is GaAs (Gallium Arsenide), which is designated as harmful substance according to the law concerned.**

**Keep the law concerned and so on, especially in case of removal.**

No part of this document may be copied or reproduced in any form or by any means without the prior written consent of NEC Corporation. NEC Corporation assumes no responsibility for any errors which may appear in this document.

NEC Corporation does not assume any liability for infringement of patents, copyrights or other intellectual property rights of third parties by or arising from use of a device described herein or any other liability arising from use of such device. No license, either express, implied or otherwise, is granted under any patents, copyrights or other intellectual property rights of NEC Corporation or others.

While NEC Corporation has been making continuous effort to enhance the reliability of its semiconductor devices, the possibility of defects cannot be eliminated entirely. To minimize risks of damage or injury to persons or property arising from a defect in an NEC semiconductor device, customers must incorporate sufficient safety measures in its design, such as redundancy, fire-containment, and anti-failure features.

NEC devices are classified into the following three quality grades:

"Standard", "Special", and "Specific". The Specific quality grade applies only to devices developed based on a customer designated "quality assurance program" for a specific application. The recommended applications of a device depend on its quality grade, as indicated below. Customers must check the quality grade of each device before using it in a particular application.

**Standard:** Computers, office equipment, communications equipment, test and measurement equipment, audio and visual equipment, home electronic appliances, machine tools, personal electronic equipment and industrial robots

**Special:** Transportation equipment (automobiles, trains, ships, etc.), traffic control systems, anti-disaster systems, anti-crime systems, safety equipment and medical equipment (not specifically designed for life support)

**Specific:** Aircrafts, aerospace equipment, submersible repeaters, nuclear reactor control systems, life support systems or medical equipment for life support, etc.

The quality grade of NEC devices is "Standard" unless otherwise specified in NEC's Data Sheets or Data Books. If customers intend to use NEC devices for applications other than those specified for Standard quality grade, they should contact an NEC sales representative in advance.

Anti-radioactive design is not implemented in this product.