

128 × 8-Bit Random-Access Memory

The MCM6810 is a byte-organized memory designed for use in bus-organized systems. It is fabricated with N-channel silicon-gate technology. For ease of use, the device operates from a single power supply, has compatibility with TTL and DTL, and needs no clocks or refreshing because of static operation.

The memory is compatible with the M6800 Microcontroller Family, providing random storage in byte increments. Memory expansion is provided through multiple Chip Select inputs.

- Organized as 128 Bytes of 8 Bits
- Static Operation
- Bidirectional Three-State Data Input/Output
- Six Chip Select Inputs (Four Active Low, Two Active High)
- Single 5-Vol Power Supply
- TTL Compatible
- Maximum Access Time = 450 ns — MCM6810
360 ns — MCM68A10
250 ns — MCM68B10

3

NOT RECOMMENDED FOR NEW DESIGN

This document contains information on a new product. Specifications and information herein are subject to change without notice.

MCM6810 RANDOM ACCESS MEMORY
BLOCK DIAGRAM

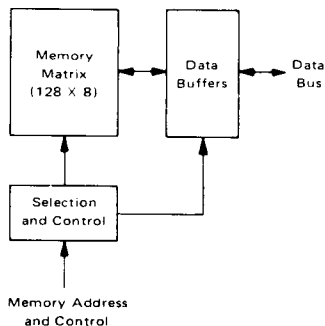

M6800 MICROCOMPUTER FAMILY
BLOCK DIAGRAM

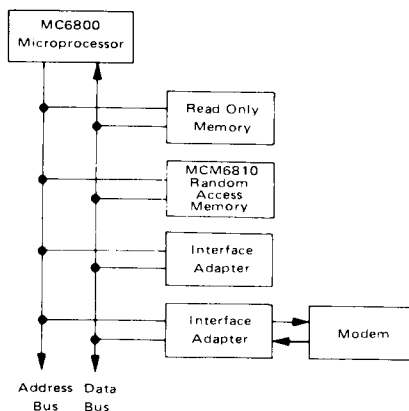

MAXIMUM RATINGS

Rating	Symbol	Value	Unit
Supply Voltage	V_{CC}	-0.3 to +7.0	V
Input Voltage	V_{in}	-0.3 to +7.0	V
Operating Temperature Range MCM6810, MCM68A10, MCM68B10 MCM6810C, MCM68A10C	T_A	T_L to T_H 0 to +70 -40 to +85	°C
Storage Temperature Range	T_{stg}	-65 to +150	°C

This device contains circuitry to protect the inputs against damage due to high static voltages or electric fields; however, it is advised that normal precautions be taken to avoid application of any voltage higher than maximum rated voltages to this high impedance circuit. Reliability of operation is enhanced if unused inputs are tied to an appropriate logic voltage (e.g., either V_{SS} or V_{CC}).

THERMAL CHARACTERISTICS

Characteristic	Symbol	Value	Unit
Thermal Resistance Plastic Cerdip	θ_{JA}	120 65	°C/W

POWER CONSIDERATIONS

The average chip-junction temperature, T_J , in °C can be obtained from:

$$T_J = T_A + (P_D \cdot \theta_{JA}) \tag{1}$$

where:

- T_A = Ambient Temperature, °C
- θ_{JA} = Package Thermal Resistance, Junction-to-Ambient, °C/W
- P_D = $P_{INT} + P_{PORT}$
- P_{INT} = $I_{CC} \times V_{CC}$, Watts — Chip Internal Power
- P_{PORT} = Port Power Dissipation, Watts — User Determined

For most applications $P_{PORT} < P_{INT}$ and can be neglected. P_{PORT} may become significant if the device is configured to drive Darlington bases or sink LED loads.

An approximate relationship between P_D and T_J (if P_{PORT} is neglected) is:

$$P_D = K \div (T_J + 273^\circ\text{C}) \tag{2}$$

Solving equations (1) and (2) for K gives $K = P_D \cdot (T_A + 273^\circ\text{C}) + \theta_{JA} \cdot P_D^2$ (3)

where K is a constant pertaining to the particular part. K can be determined from equation (3) by measuring P_D (at equilibrium) for a known T_A . Using this value of K, the values of P_D and T_J can be obtained by solving equations (1) and (2) iteratively for any value of T_A .



MC6810

BLOCK DIAGRAM

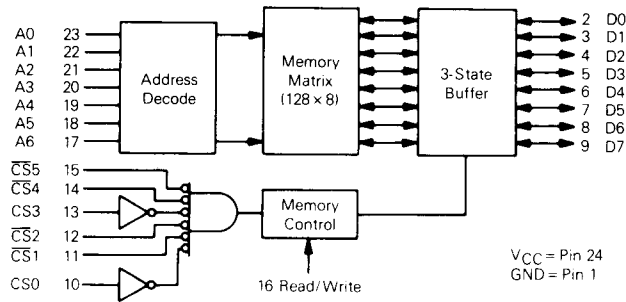

DC ELECTRICAL CHARACTERISTICS ($V_{CC}=5.0\text{ Vdc} \pm 5\%$, $V_{SS}=0$, $T_A=T_L$ to T_H unless otherwise noted)

Characteristic	Symbol	Min	Max	Unit
Input High Voltage	V_{IH}	$V_{SS}+2.0$	V_{CC}	V
Input Low Voltage	V_{IL}	$V_{SS}-0.3$	$V_{SS}+0.8$	V
Input Current (I_{IN} , R/W, \overline{CS}_n) ($V_{IN}=0$ to 5.25 V)	I_{IN}	—	2.5	μA
Output High Voltage ($I_{OH} = -205\ \mu\text{A}$)	V_{OH}	2.4	—	V
Output Low Voltage ($I_{OL} = 1.6\ \text{mA}$)	V_{OL}	—	0.4	V
Output Leakage Current (Three-State) ($CS = 0.8\text{ V}$ or $\overline{CS} = 2.0\text{ V}$, $V_{OUT} = 0.4\text{ V}$ to 2.4 V)	I_{TS}	—	10	μA
Supply Current ($V_{CC} = 5.25\text{ V}$, All Other Pins Grounded)	I_{CC}	—	80	mA
		1.0 MHz	—	
		1.5, 2.0 MHz	100	
Input Capacitance (I_{IN} , R/W, CS_n , \overline{CS}_n) ($V_{IN}=0$, $T_A = 25^\circ\text{C}$, $f = 1.0\text{ MHz}$)	C_{IN}	—	7.5	pF
Output Capacitance (D_n) ($V_{OUT}=0$, $T_A = 25^\circ\text{C}$, $f = 1.0\text{ MHz}$, $CS_0 = 0$)	C_{OUT}	—	12.5	pF

AC TEST LOAD

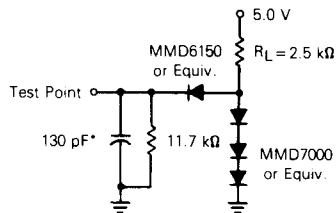

*Includes Jig Capacitance

AC OPERATING CONDITIONS AND CHARACTERISTICS

READ CYCLE ($V_{CC} = 5.0\text{ V} \pm 5\%$, $V_{SS} = 0$, $T_A = T_L$ to T_H unless otherwise noted.)

Characteristic	Symbol	MCM6810		MCM68A10		MCM68B10		Unit
		Min	Max	Min	Max	Min	Max	
Read Cycle Time	$t_{cyc}(R)$	450	—	360	—	250	—	ns
Access Time	t_{acc}	—	450	—	360	—	250	ns
Address Setup Time	t_{AS}	20	—	20	—	20	—	ns
Address Hold Time	t_{AH}	0	—	0	—	0	—	ns
Data Delay Time (Read)	t_{DDR}	—	230	—	220	—	180	ns
Read to Select Delay Time	t_{RCS}	0	—	0	—	0	—	ns
Data Hold from Address	t_{DHA}	10	—	10	—	10	—	ns
Output Hold Time	t_H	10	—	10	—	10	—	ns
Data Hold from Read	t_{DHR}	10	80	10	60	10	60	ns
Read Hold from Chip Select	t_{RH}	0	—	0	—	0	—	ns

READ CYCLE TIMING

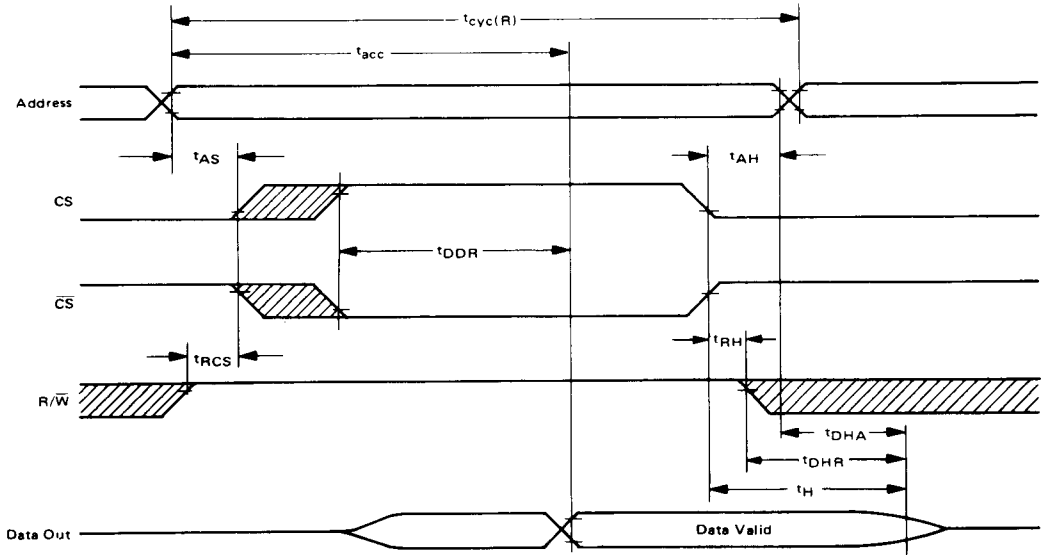

NOTES:

1. Voltage levels shown are $V_L \leq 0.4 \text{ V}$, $V_H \geq 2.4 \text{ V}$, unless otherwise specified.
2. Measurement points shown are 0.8 V and 2.0 V, unless otherwise specified.
3. CS and $\overline{\text{CS}}$ have same timing.

= Don't Care

WRITE CYCLE ($V_{CC} = 5.0 \text{ V} \pm 5\%$, $V_{SS} = 0$, $T_A = T_L$ to T_H unless otherwise noted.)

Characteristic	Symbol	MCM6810		MCM68A10		MCM68B10		Unit
		Min	Max	Min	Max	Min	Max	
Write Cycle Time	$t_{\text{cyc(W)}}$	450	—	360	—	250	—	ns
Address Setup Time	t_{AS}	20	—	20	—	20	—	ns
Address Hold Time	t_{AH}	0	—	0	—	0	—	ns
Chip Select Pulse Width	t_{CS}	300	—	250	—	210	—	ns
Write to Chip Select Delay Time	t_{WCS}	0	—	0	—	0	—	ns
Data Setup Time (Write)	t_{DSW}	190	—	80	—	60	—	ns
Input Hold Time	t_{H}	10	—	10	—	10	—	ns
Write Hold Time from Chip Select	t_{WH}	0	—	0	—	0	—	ns

Motorola reserves the right to make changes without further notice to any products herein to improve reliability, function or design. Motorola does not assume any liability arising out of the application or use of any product or circuit described herein; neither does it convey any license under its patent rights nor the rights of others. Motorola products are not authorized for use as components in life support devices or systems intended for surgical implant into the body or intended to support or sustain life. Buyer agrees to notify Motorola of any such intended end use whereupon Motorola shall determine availability and suitability of its product or products for the use intended. Motorola and are registered trademarks of Motorola, Inc. Motorola, Inc. is an Equal Employment Opportunity/Affirmative Action Employer.

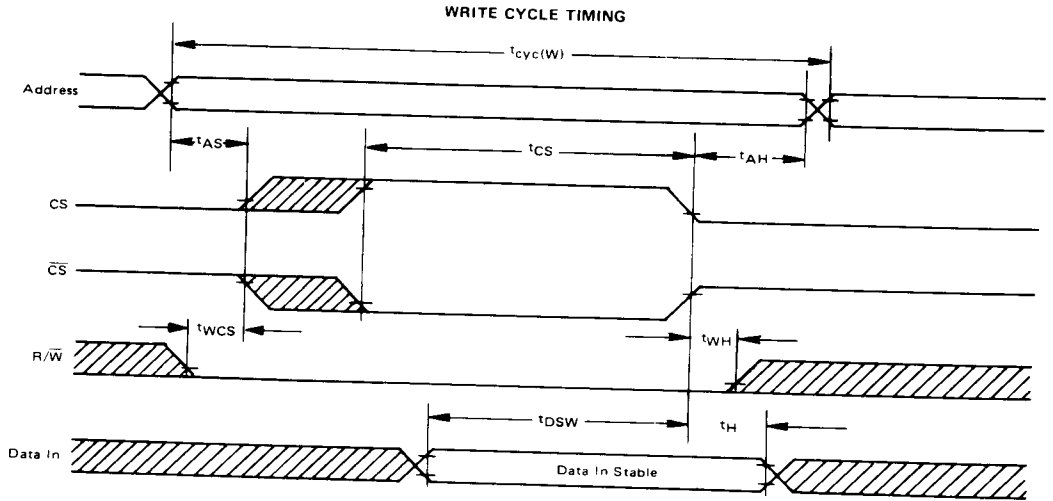

3

NOTES:

1. Voltage levels shown are $V_L \leq 0.4$ V, $V_H \geq 2.4$ V, unless otherwise specified.
2. Measurement points shown are 0.8 V and 2.0 V, unless otherwise specified.
3. CS and CS-bar have same timing.

- Don't Care

ORDERING INFORMATION

Package Type	Frequency (MHz)	Temperature	Order Number
Plastic P Suffix	1.0	0°C to 70°C	MCM6810P
	1.0	-40°C to 85°C	MCM6810CP
	1.5	0°C to 70°C	MCM68A10P
	1.5	-40°C to 85°C	MCM68A10CP
	2.0	0°C to 70°C	MCM68B10P
Cerdip S Suffix	1.0	0°C to 70°C	MCM6810S
	1.0	-40°C to 85°C	MCM6810CS
	1.5	0°C to 70°C	MCM68A10S
	1.5	-40°C to 85°C	MCM68A10CS
	2.0	0°C to 70°C	MCM68B10S

PIN ASSIGNMENTS

