

# 8-bit Proprietary Microcontroller

CMOS

## F<sup>2</sup>MC-8L MB89130/130A Series

### MB89131/P131/133A/P133A/135A/ MB89P135A/PV130A

#### ■ DESCRIPTION

The MB89130/130A series has been developed as a general-purpose version of the F<sup>2</sup>MC\*-8L family consisting of proprietary 8-bit, single-chip microcontrollers.

In addition to a compact instruction set, the microcontrollers contain a great variety of peripheral functions such as timers, a serial interface, an A/D converter, and external interrupts. The MB89130A series also include a remote control transmitting output and wake-up interrupt function.

\* : F<sup>2</sup>MC stands for FUJITSU Flexible Microcontroller.

#### ■ FEATURES

- F<sup>2</sup>MC-8L family CPU core
- Low-voltage operation (when an A/D converter is not used)
- Low current consumption (applicable to the dual-clock system)
- Minimum execution time : 0.95  $\mu$ s at 4.2 MHz
- 21-bit timebase timer
- I/O ports : max. 36 ports
- External interrupt 1 : 3 channels
- External interrupt 2 (wake-up function) : 8 channels (only for the MB89130A series)
- 8-bit serial I/O : 1 channel

(Continued)

#### ■ PACKAGE

48-pin plastic QFP

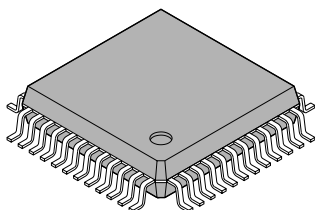

(FPT-48P-M13)

48-pin plastic SH-DIP

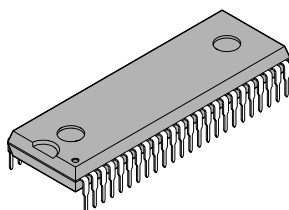

(DIP-48P-M01)

48-pin ceramic MQFP

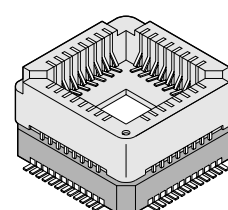

(MQP-48C-P01)

# MB89130/130A Series

(Continued)

- 8/16-bit timer/counter : 1 channel
- 8-bit A/D converter : 4 channels
- Remote control transmitting frequency generator (for the MB89130A series only)
- Low-power consumption modes (stop, sleep, and watch mode)
- QFP-48 package, SH-DIP-48 package
- CMOS technology

## ■ PRODUCT LINEUP

Part number Item	MB89131	MB89133A	MB89135A	MB89P133A	MB89P131
Classification	Mass-produced products (mask ROM products)			One-time PROM products	
ROM size	4 K × 8 bits (internal mask ROM)	8 K × 8 bits (internal mask ROM)	16 K × 8 bits (internal mask ROM)	8 K × 8 bits (internal PROM, to be programmed with general- purpose EPROM programmer)	4 K × 8 bits (internal PROM, to be programmed with general- purpose EPROM programmer)
RAM size	128 × 8 bits	256 × 8 bits			128 × 8 bits
CPU functions	The number of instructions :		136		
	Instruction bit length :		8 bits		
	Instruction length :		1 to 3 bytes		
	Data bit length :		1, 8, 16 bits		
	Minimum execution time :		0.95 μs at 4.2 MHz		
	Minimum interrupt processing time :		8.57 μs at 4.2 MHz		
Ports	Output ports (N-ch open-drain ports) :		4 (All also serve as peripherals.)		
	Output ports (CMOS) :		8		
	I/O ports (CMOS) :		24 (8 ports also serve as peripherals. For MB89130A, 16 ports also serve as.)		
	Total :		36		
8/16-bit timer/ counter	8-bit timer/counter × 2 channels or a 16-bit event counter				
8-bit serial I/O	8 bits LSB/MSB first selectable				
8-bit A/D converter	8-bit resolution × 4 channels A/D conversion mode (minimum conversion time : 42 μs at 4.2 MHz) Sense mode (minimum conversion time : 11.4 μs at 4.2 MHz) Capable of continuous activation by an internal timer Reference voltage input				
External interrupt 1	3 independent channels (edge selection, interrupt vector, source flag) Rising/falling both edges selectable Used also for wake-up from stop/sleep mode. (Edge detection is also permitted in the stop mode.)				

(Continued)

# MB89130/130A Series

Part number Item	MB89131	MB89133A	MB89135A	MB89P133A	MB89P131
External interrupt 2 (wake-up function)	—	8 channels (only for level detection)			—
Remote control transmitting gener- ator	—	1 channel (Pulse width and cycle selectable by program)			—
Standby mode	Sleep, stop, and clock mode				
Process	CMOS				
Operating voltage*	2.2 to 4.0 V (with the dual-clock option) 2.2 to 6.0 V (with the single-clock option)			2.7 V to 6.0 V	

\* : Varies with conditions such as the operating frequency. (See "■ ELECTRICAL CHARACTERISTICS".)

(Continued)

# MB89130/130A Series

(Continued)

Part number Item	MB89P135	MB89PV130A
Classification	One-time PROM products	Piggyback/evaluation product
ROM size	16 K × 8 bits (internal PROM, to be programmed with general-purpose EPROM programmer)	32 K × 8 bits (external ROM)
RAM size	512 × 8 bits	1 K × 8 bits
CPU functions	The number of instructions : 136 Instruction bit length : 8 bits Instruction length : 1 to 3 bytes Data bit length : 1, 8, 16 bits Minimum execution time : 0.95 μs at 4.2 MHz Minimum interrupt processing time : 8.57 μs at 4.2 MHz	
Ports	Output ports (N-ch open-drain ports) : 4 (All also serve as peripherals.) Output ports (CMOS) : 8 I/O ports (CMOS) : 24 (8 ports also serve as peripherals. For MB89130A, 16 ports also serve as peripherals.) Total : 36	
8/16-bit timer/ counter	8-bit timer/counter × 2 channels or a 16-bit event counter	
8-bit serial I/O	8 bits LSB/MSB first selectable	
8-bit A/D converter	8-bit resolution × 4 channels A/D conversion mode (minimum conversion time : 42 μs at 4.2 MHz) Sense mode (minimum conversion time : 11.4 μs at 4.2 MHz) Capable of continuous activation by an internal timer Reference voltage input	
External interrupt 1	3 independent channels (selectable edge, interrupt vector, source flag) Rising/falling both edges selectable Used also for wake-up from the stop/sleep mode. (Edge detection is also permitted in the stop mode.)	
External interrupt 2 (wake-up function)	8 channels (only for level detection)	
Remote control transmitting frequency generator	1 channel (Pulse width and cycle selectable by program)	
Standby mode	Sleep, stop, and clock mode	
Process	CMOS	
Operating voltage	2.7 V to 6.0 V	2.7 V to 6.0 V
EPROM for use	—	MBM27C256A-20TVM

## ■ PACKAGE AND CORRESPONDING PRODUCTS

Package	MB89131	MB89133A	MB89135A	MB89P133A	MB89P131
FPT-48P-M13	○	○	○	○	○
DIP-48P-M01	×	○	×	○	×
MQP-48C-P01	×	×	×	×	×

Package	MB89P135A	MB89PV130A
FPT-48P-M13	○	×
DIP-48P-M01	×	×
MQP-48C-P01	×	○

○ : Available, × : Not available

## ■ DIFFERENCES AMONG PRODUCTS

### 1. Memory Size

Before evaluating using the OTPROM (one-time PROM) products, verify its differences from the product that will actually be used. Take particular care on the following points :

- The number of register banks available is different among the MB89131, MB89133A/135A and MB89P135A/PV130A.
- The stack area, etc., is set at the upper limit of the RAM.

### 2. Current Consumption

- When operated at low speed, the product with an OTPROM will consume more current than the product with a mask ROM.

However, the same is current consumption in sleep/stop modes. (For more information, see “■ ELECTRICAL CHARACTERISTICS”.)

- In the case of the MB89PV130A, added is the current consumed by the EPROM which is connected to the top socket.

### 3. Mask Options

Functions that can be selected as options and how to designate these options vary with product.

Before using options, check “■ MASK OPITONS”.

Take particular care on the following point :

- P40 to P43 must be set to no pull-up resistor when an A/D converter is used.
- For MB89P135A, pull-up resistor option cannot be set for P40 to P43.
- Each option is fixed on the MB89PV130A.

# MB89130/130A Series

## ■ PIN ASSIGNMENT

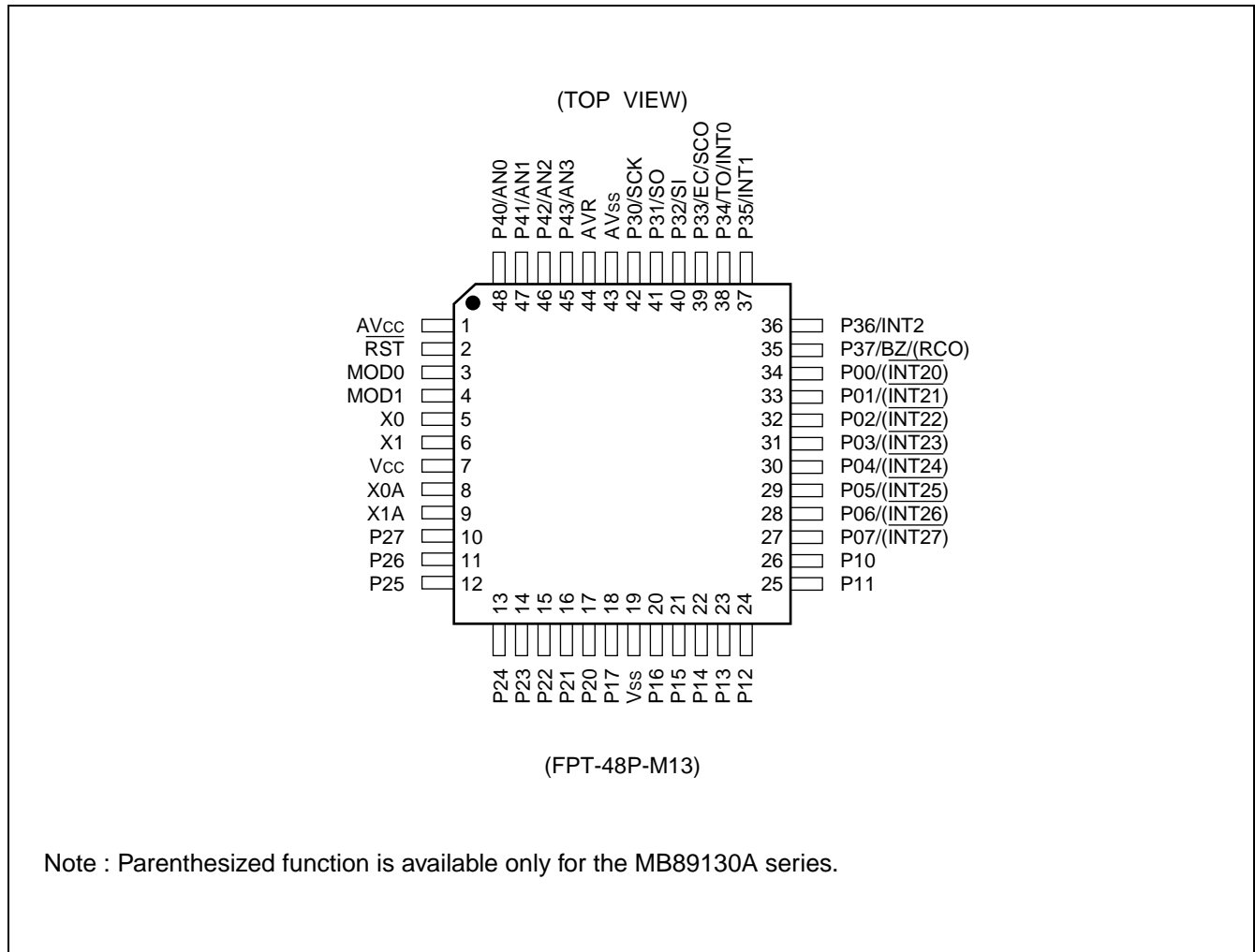

# MB89130/130A Series

(TOP VIEW)

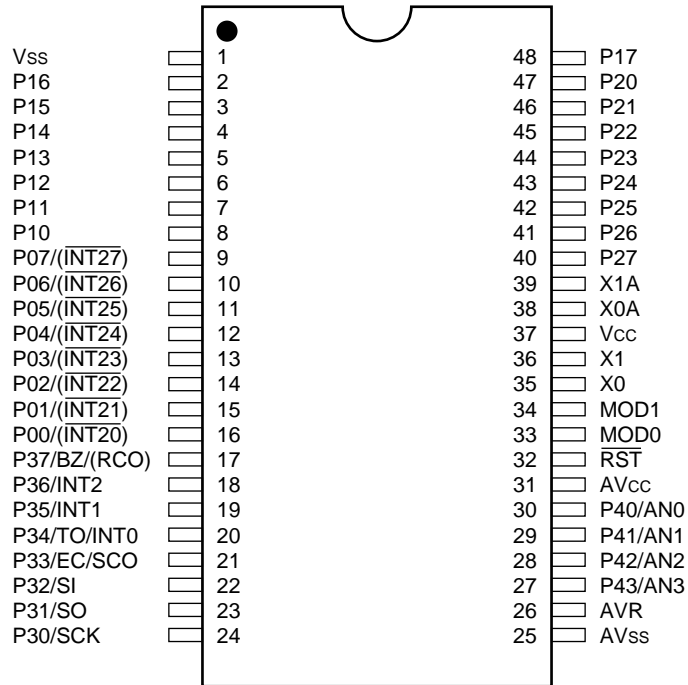

(DIP-48P-M01)

Note : Parenthesized function is available only for the MB89130A series.

# MB89130/130A Series

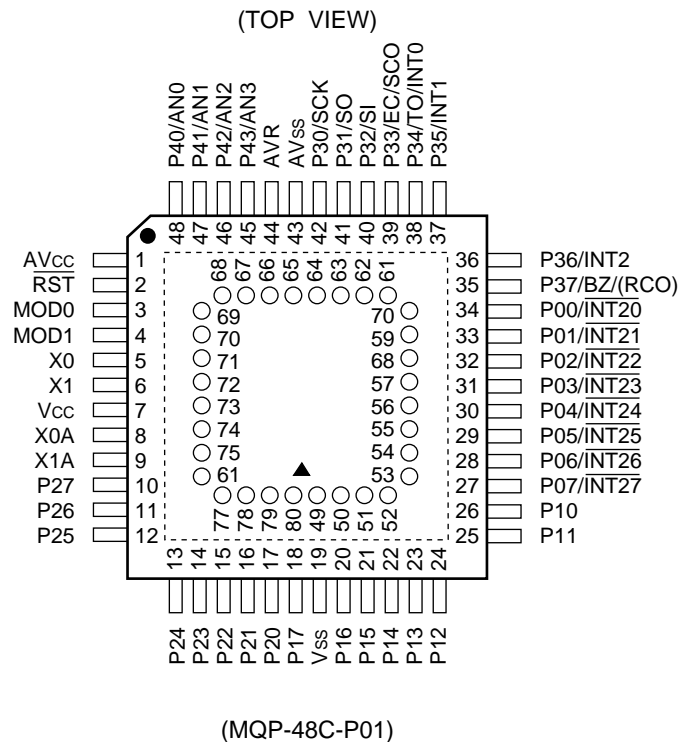

• Pin assignment on package top

Pin no.	Pin name	Pin no.	Pin name	Pin no.	Pin name	Pin no.	Pin name
49	V <sub>PP</sub>	57	N.C.	65	O4	73	$\overline{OE}$
50	A12	58	A2	66	O5	74	N.C.
51	A7	59	A1	67	O6	75	A11
52	A6	60	A0	68	O7	76	A9
53	A5	61	O1	69	O8	77	A8
54	A4	62	O2	70	$\overline{CE}$	78	A13
55	A3	63	O3	71	A10	79	A14
56	N.C.	64	V <sub>SS</sub>	72	N.C.	80	V <sub>CC</sub>

N.C. : Internally connected. Do not use.



# MB89130/130A Series

## ■ PIN DESCRIPTION

Pin no.		Pin name	Circuit type	Function
SH-DIP <sup>*1</sup>	QFP <sup>*2</sup>			
35	5	X0	A	Main clock crystal oscillator pins (max. 4.2 MHz)
36	6	X1		
38	8	X0A	B	Subclock crystal oscillator pins (32.768 kHz)
39	9	X1A		
33	3	MOD0	C	Operation mode selecting pins Connect directly to V <sub>SS</sub> .
34	4	MOD1		
32	2	$\overline{\text{RST}}$	D	Reset I/O pin This pin is of N-ch open-drain output type with pull-up resistor, and a hysteresis input type. The internal circuit is initialized by the input of "L". "L" is output from this pin by an internal reset source as a option.
16 to 9	34 to 27	P00 ( $\overline{\text{INT20}}$ ) to P07 ( $\overline{\text{INT27}}$ )	I	General-purpose I/O ports On the MB89130A series, these ports also serve as an external interrupt input. External interrupt inputs are of hysteresis input type.
8 to 2, 48	26 to 20, 18	P10 to P17	E	General-purpose I/O ports
47 to 40	17 to 10	P20 to P27	G	General-purpose output ports
24	42	P30/SCK	F	General-purpose I/O port Also serves as the clock I/O for the 8-bit serial I/O. This port is of hysteresis input type.
23	41	P31/SO	F	General-purpose I/O port Also serves as a 8-bit serial I/O data output. This port is of hysteresis input type.
22	40	P32/SI	F	General-purpose I/O port Also serves as a 8-bit serial I/O data input. This port is of hysteresis input type.
21	39	P33/EC/SCO	F	General-purpose I/O port Also serves as the external clock input for the 8-bit timer/counter. This port is of hysteresis input type. The system clock output is provided as an option.
20	38	P34/TO/INT0	F	General-purpose I/O port Also serve as the overflow output for the 8-bit timer/counter and an external interrupt input. This port is of hysteresis input type.
19, 18	37, 36	P35/INT1, P36/INT2	F	General-purpose I/O ports Also serves as an external interrupt input. These ports are of hysteresis input type.

\*1 : DIP-48P-M01

\*2 : FPT-48P-M13

(Continued)

# MB89130/130A Series

(Continued)

Pin no.		Pin name	Circuit type	Function
SH-DIP*1	QFP*2			
17	35	P37/BZ/ (RCO)	F	General-purpose I/O port Also serves as a buzzer output. This port is of hysteresis input type. On the MB89130A series, this port also serves as a remote control output.
30 to 27	48 to 45	P40/AN0 to P43/AN3	H	N-ch open-drain output ports Also serve as an analog input for the A/D converter.
37	7	V <sub>cc</sub>	—	Power supply pin
1	19	V <sub>ss</sub>	—	Power supply (GND) pin
31	1	AV <sub>cc</sub>	—	A/D converter power supply pin Use this pin at the same voltage as V <sub>cc</sub> .
26	44	AVR	—	A/D converter reference voltage input pin
25	43	AV <sub>ss</sub>	—	A/D converter power supply pin Use this pin at the same voltage as V <sub>ss</sub> .

\*1 : DIP-48P-M01

\*2 : FPT-48P-M13

# MB89130/130A Series

• External EPROM pins (MB89PV130A only)

Pin no.	Pin name	I/O	Function
49	V <sub>PP</sub>	O	"H" level output pin
50	A12	O	Address output pins
51	A7		
52	A6		
53	A5		
54	A4		
55	A3		
58	A2		
59	A1		
60	A0		
61	O1	I	Data input pins
62	O2		
63	O3		
64	V <sub>SS</sub>	O	Power supply (GND) pin
65	O4	I	Data input pins
66	O5		
67	O6		
68	O7		
69	O8		
70	$\overline{CE}$	O	ROM chip enable pin Outputs "H" during standby.
71	A10	O	Address output pin
73	$\overline{OE}$	O	ROM output enable pin Outputs "L" at all times.
75	A11	O	Address output pins
76	A9		
77	A8		
78	A13		
79	A14		
80	V <sub>CC</sub>	O	EPROM power supply pin
56	N.C.	—	Internally connected pins Be sure to leave them open.
57			
72			
74			

# MB89130/130A Series

## I/O CIRCUIT TYPE

Type	Circuit	Remarks
A	<p>Standby control signal</p>	<ul style="list-style-type: none"> <li>Crystal or ceramic oscillation type (main clock)</li> <li>Circuit for the MB89P133A/P131/P135A/PV130A</li> <li>External clock input selecting versions of MB89131/133A/135A</li> <li>Oscillation feedback resistor of approximately 1 M<math>\Omega</math>/5 V</li> </ul>
	<p>Standby control signal</p>	<ul style="list-style-type: none"> <li>Crystal or ceramic oscillation type (main clock)</li> <li>Crystal or ceramic oscillation selecting versions of MB89131/133A/135A</li> <li>Oscillation feedback resistor of approximately 1 M<math>\Omega</math>/5 V</li> </ul>
B	<p>Standby control signal</p>	<ul style="list-style-type: none"> <li>Crystal and ceramic oscillation type (subclock)</li> <li>Circuit for the MB89131/133A/135A</li> <li>Oscillation feedback resistor of approximately 4.5 M<math>\Omega</math>/5 V</li> </ul>
	<p>Standby control signal</p>	<ul style="list-style-type: none"> <li>Crystal and ceramic oscillation type (subclock)</li> <li>Circuit for the MB89P131/P133A/P135A/PV130A</li> <li>Oscillation feedback resistor of approximately 4.5 M<math>\Omega</math>/5 V</li> </ul>
C		
D		<ul style="list-style-type: none"> <li>Output pull-up resistor (P-ch) of approximately 50 k<math>\Omega</math>/5 V</li> <li>Hysteresis input</li> </ul>

(Continued)

# MB89130/130A Series

(Continued)

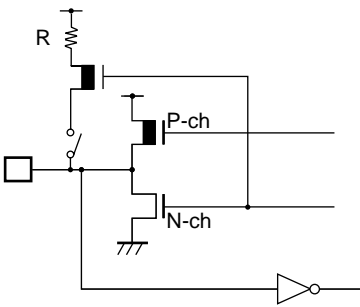
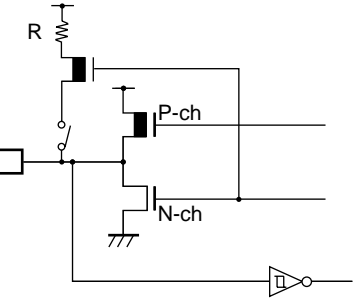
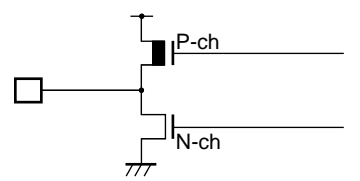
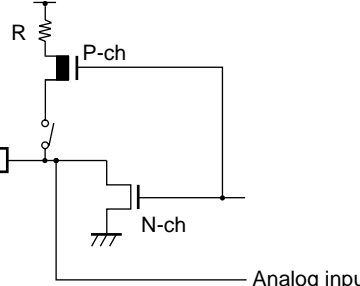
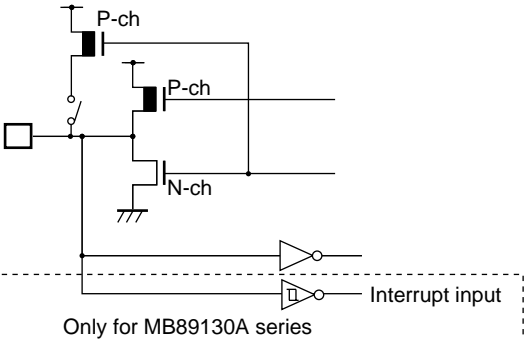
Type	Circuit	Remarks
E		<ul style="list-style-type: none"> <li>• CMOS output</li> <li>• CMOS input</li> </ul>
F		<ul style="list-style-type: none"> <li>• CMOS output</li> <li>• Hysteresis input</li> </ul>
G		<ul style="list-style-type: none"> <li>• CMOS output</li> </ul>
H		<ul style="list-style-type: none"> <li>• N-ch open-drain output</li> <li>• Analog input</li> </ul>
I		<ul style="list-style-type: none"> <li>• CMOS output</li> <li>• CMOS input</li> <li>• The interrupt input is a hysteresis input (available only for the MB89130A series) .</li> </ul>

## ■ HANDLING DEVICES

### 1. Preventing Latchup

Latchup may occur on CMOS ICs if voltage higher than  $V_{CC}$  or lower than  $V_{SS}$  is applied to input and output pins other than medium- and high-voltage pins or if higher than the voltage which shows on “1. Absolute Maximum Ratings” in “■ Electrical Characteristics” is applied between  $V_{CC}$  and  $V_{SS}$ .

When latchup occurs, power supply current increases rapidly and might thermally damage elements. When using, take great care not to exceed the absolute maximum ratings.

Also, take care to prevent the analog power supply ( $AV_{CC}$  and  $AVR$ ) and analog input from exceeding the digital power supply ( $V_{CC}$ ) when the analog system power supply is turned on and off.

### 2. Treatment of Unused Input Pins

Leaving unused input pins open could cause malfunctions. They should be connected to a pull-up or pull-down resistor.

### 3. Treatment of Power Supply Pins on Microcontrollers with A/D Converter

Connect to be  $AV_{CC} = V_{CC}$  and  $AV_{SS} = AVR = V_{SS}$  even if the A/D converter are not in use.

### 4. Treatment of N.C. Pins

Be sure to leave (internally connected) N.C. pins open.

### 5. Power Supply Voltage Fluctuations

Although operation is assured within the rated range of  $V_{CC}$  power supply voltage, a rapid fluctuation of the voltage could cause malfunctions, even if it occurs within the rated range. Stabilizing voltage supplied to the IC is therefore important. As stabilization guidelines, it is recommended to control power so that  $V_{CC}$  ripple fluctuations (P-P value) will be less than 10% of the standard  $V_{CC}$  value at the commercial frequency (50 to 60 Hz) and the transient fluctuation rate will be less than 0.1 V/ms at the time of a momentary fluctuation such as when power is switched.

### 6. Precautions when Using an External Clock

When an external clock is used, oscillation stabilization time is required even for power-on reset (optional) and wake-up from stop mode.

### 7. Turning on the supply voltage (only for the MB89P135A)

Power on sharply up to the option enabling voltage (2 V) within 13 clock cycles after starting of oscillation.

## ■ PROGRAMMING TO THE EPROM ON THE MB89P131

The MB89P131 is an OTPROM version of the MB89131.

### 1. Features

- 4-Kbyte PROM on chip
- Equivalency to the MBM27C256A in EPROM mode (when programmed with the EPROM programmer)

### 2. Memory Space

Memory space in EPROM mode is diagrammed below.

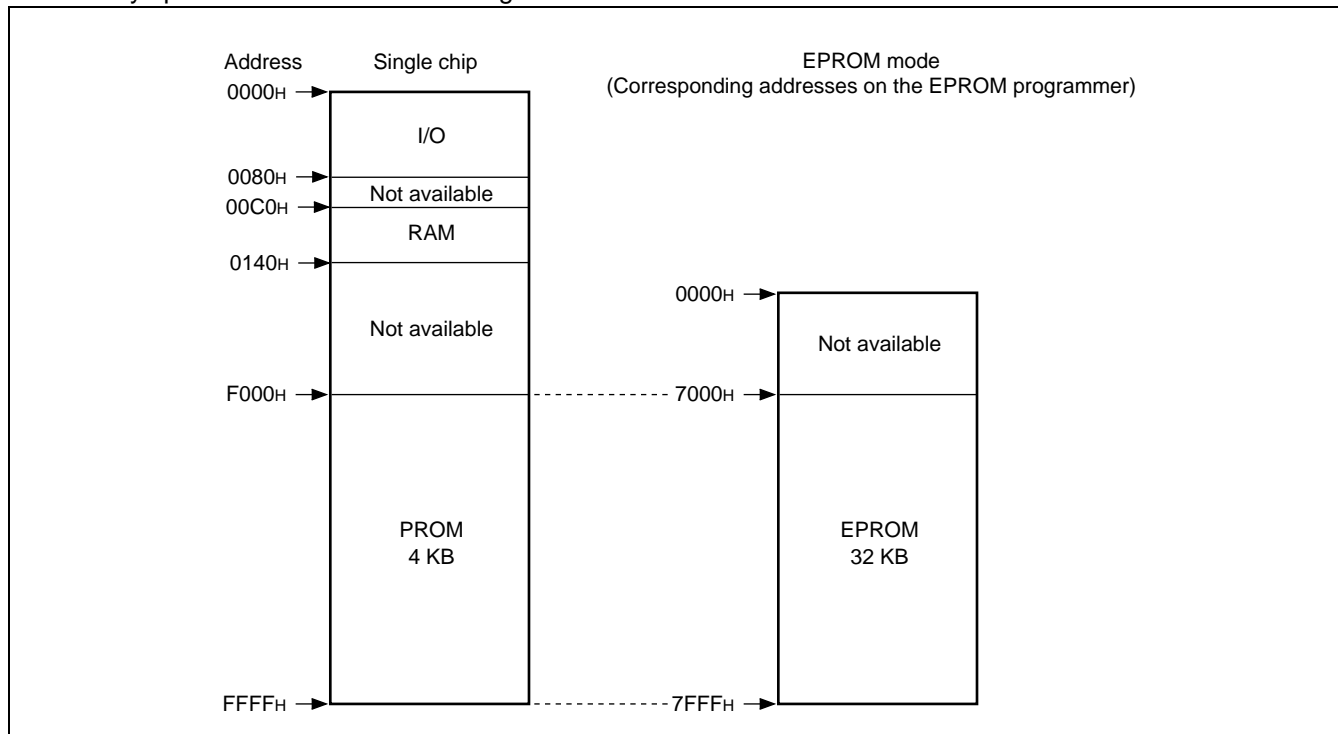

### 3. Programming to the EPROM

In EPROM mode, the MB89P131 functions equivalent to the MBM27C256A. This allows the PROM to be programmed with a general-purpose EPROM programmer (the electronic signature mode cannot be used) by using the dedicated socket adapter.

#### • Programming procedure

- (1) Set the EPROM programmer for the MBM27C256A.
- (2) Load program data into the EPROM programmer at 7000H to 7FFFH (note that addresses F000H to FFFFH while operating as a single chip correspond to 7000H to 7FFFH in EPROM mode) .
- (3) Program with the EPROM programmer.

# MB89130/130A Series

## ■ PROGRAMMING TO THE EPROM ON THE MB89P133A

The MB89P133A is an OTPROM version of the MP89133A.

### 1. Features

- 8-Kbyte PROM on chip
- Equivalency to the MBM27C256A in EPROM mode (when programmed with the EPROM programmer)

### 2. Memory Space

Memory space in EPROM mode is diagrammed below.

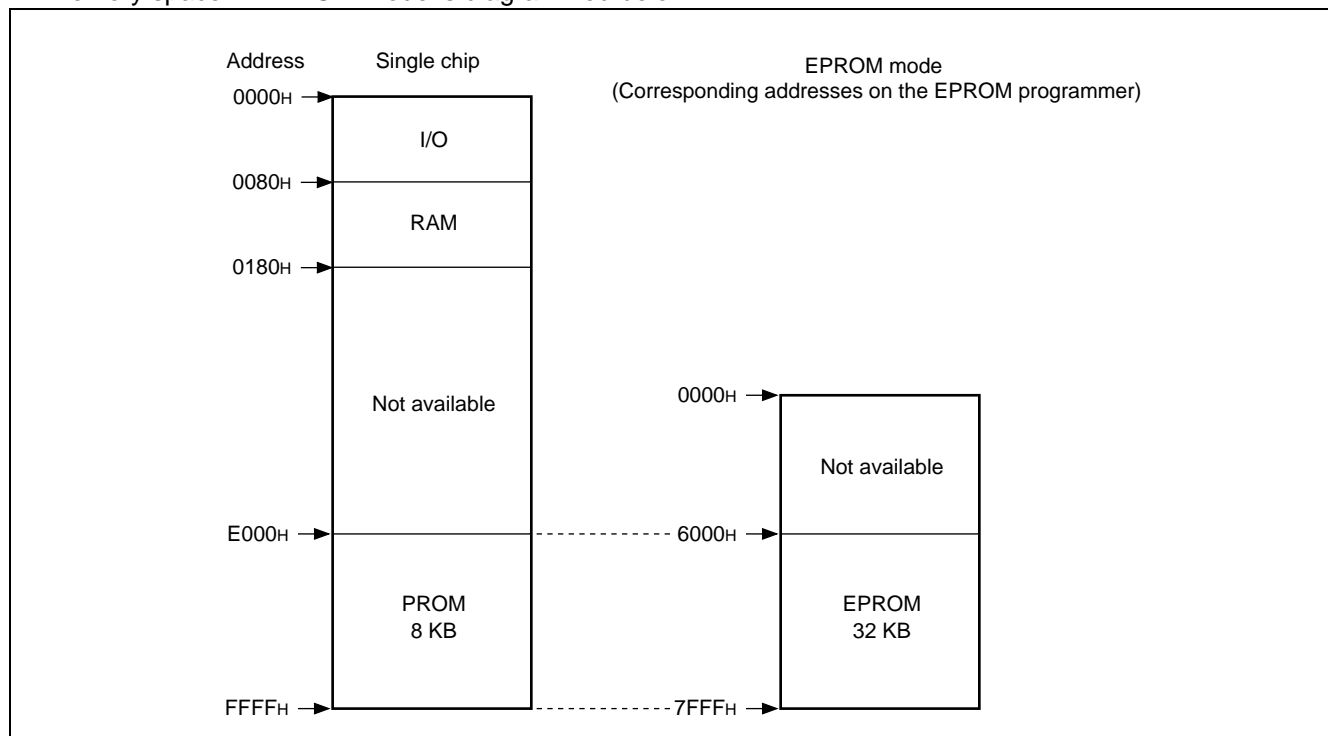

### 3. Programming to the EPROM

In EPROM mode, the MB89P133A functions equivalent to the MBM27C256A. This allows the PROM to be programmed with a general-purpose EPROM programmer (the electronic signature mode cannot be used) by using the dedicated socket adapter.

#### • Programming procedure

- (1) Set the EPROM programmer for the MBM27C256A.
- (2) Load program data into the EPROM programmer at 6000<sub>H</sub> to 7FFF<sub>H</sub> (note that addresses E000<sub>H</sub> to FFFF<sub>H</sub> while operating as a single chip correspond to 6000<sub>H</sub> to 7FFF<sub>H</sub> in EPROM mode) .
- (3) Program with the EPROM programmer.



## ■ PROGRAMMING TO THE EPROM ON THE MB89P135A

The MB89P135A is an OTPROM version of the MB89133A/135A.

### 1. Features

- 16-Kbyte PROM on chip
- Equivalency to the MBM27C256A in EPROM mode (when programmed with the EPROM programmer)

### 2. Memory Space

Memory space in EPROM mode is diagrammed below.

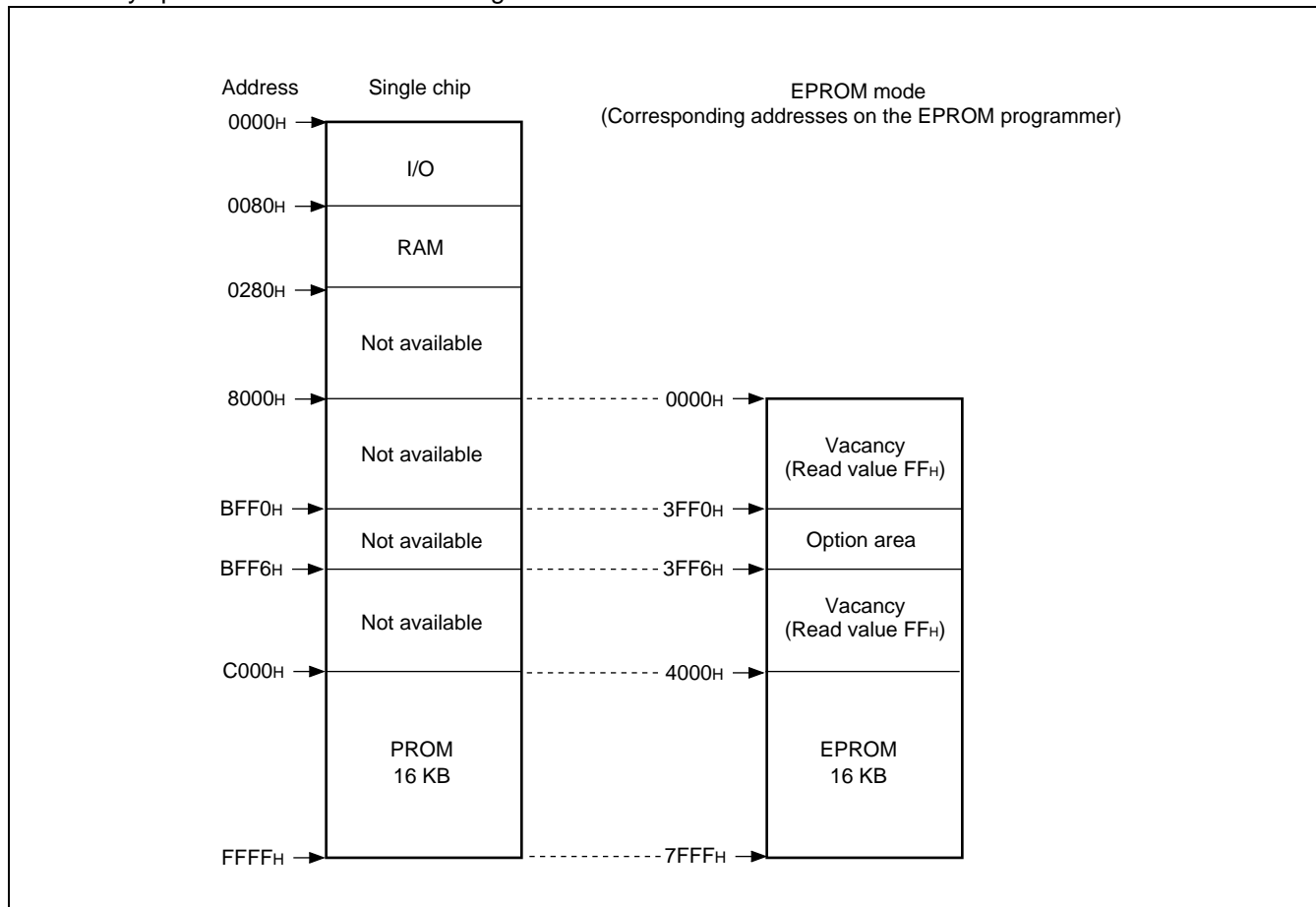

### 3. Programming to the EPROM

In EPROM mode, the MB89P135A functions equivalent to the MBM27C256A. This allows the PROM to be programmed with a general-purpose EPROM programmer (the electronic signature mode cannot be used) by using the dedicated socket adapter.

#### • Programming procedure

- (1) Set the EPROM programmer for the MBM27C256A.
- (2) Load program data into the EPROM programmer at 4000<sub>H</sub> to 7FFF<sub>H</sub> (note that addresses C000<sub>H</sub> to FFFF<sub>H</sub> while operating as a single chip correspond to 4000<sub>H</sub> to 7FFF<sub>H</sub> in EPROM mode) .
- (3) Load option data into the EPROM programmer at 3FF0<sub>H</sub> to 3FF6<sub>H</sub>.
- (4) Program with the EPROM programmer.

# MB89130/130A Series

## 4. Setting OTPROM Options (MB89P135A Only)

The programming procedure is the same as that for the PROM. Options can be set by programming values at the addresses shown on the memory map. The relationship between bits and options is shown on the following bit map :

### • OTPROM option bit map

Ad- dress	Bit 7	Bit 6	Bit 5	Bit 4	Bit 3	Bit 2	Bit 1	Bit 0
3FF0 <sub>H</sub>	Vacancy	Vacancy	Vacancy	Clock mode selection 1 : Single clock 0 : Dual clock	Reset pin output 1 : Yes 0 : No	Power-on reset 1 : Yes 0 : No	Oscillation stabilization time	
	Readable and writable	Readable and writable	Readable and writable				00 : 2 <sup>2</sup> /F <sub>CH</sub> 01 : 2 <sup>12</sup> /F <sub>CH</sub>	10 : 2 <sup>16</sup> /F <sub>CH</sub> 11 : 2 <sup>18</sup> /F <sub>CH</sub>
3FF1 <sub>H</sub>	P07 Pull-up 1 : Yes 0 : No	P06 Pul-up 1 : Yes 0 : No	P05 Pull-up 1 : Yes 0 : No	P04 Pull-up 1 : Yes 0 : No	P03 Pull-up 1 : Yes 0 : No	P02 Pull-up 1 : Yes 0 : No	P01 Pull-up 1 : Yes 0 : No	P00 Pull-up 1 : Yes 0 : No
3FF2 <sub>H</sub>	P17 Pull-up 1 : No 0 : Yes	P16 Pull-up 1 : No 0 : Yes	P15 Pull-up 1 : Yes 0 : No	P14 Pull-up 1 : Yes 0 : No	P13 Pull-up 1 : Yes 0 : No	P12 Pull-up 1 : Yes 0 : No	P11 Pull-up 1 : Yes 0 : No	P10 Pull-up 1 : Yes 0 : No
3FF3 <sub>H</sub>	P37 Pull-up 1 : Yes 0 : No	P36 Pull-up 1 : Yes 0 : No	P35 Pull-up 1 : Yes 0 : No	P34 Pull-up 1 : Yes 0 : No	P33 Pull-up 1 : Yes 0 : No	P32 Pull-up 1 : Yes 0 : No	P31 Pull-up 1 : Yes 0 : No	P30 Pull-up 1 : Yes 0 : No
3FF4 <sub>H</sub>	Vacancy	Vacancy	Vacancy	Vacancy	Vacancy	Vacancy	Vacancy	Vacancy
	Readable and writable	Readable and writable	Readable and writable	Readable and writable	Readable and writable	Readable and writable	Readable and writable	Readable and writable
3FF5 <sub>H</sub>	Vacancy	Vacancy	Vacancy	Vacancy	Vacancy	Vacancy	Vacancy	Vacancy
	Readable and writable	Readable and writable	Readable and writable	Readable and writable	Readable and writable	Readable and writable	Readable and writable	Readable and writable
3FF6 <sub>H</sub>	Vacancy	Vacancy	Vacancy	Vacancy	Vacancy	Vacancy	Vacancy	Vacancy
	Readable and writable	Readable and writable	Readable and writable	Readable and writable	Readable and writable	Readable and writable	Readable and writable	Readable and writable

Note : Each bit is set to '1' as the initialized value, therefore the pull-up option is selected.

## ■ HANDLING THE MB89P131/P133A/P135A

### 1. Recommended Screening Conditions

High-temperature aging is recommended as the pre-assembly screening procedure.

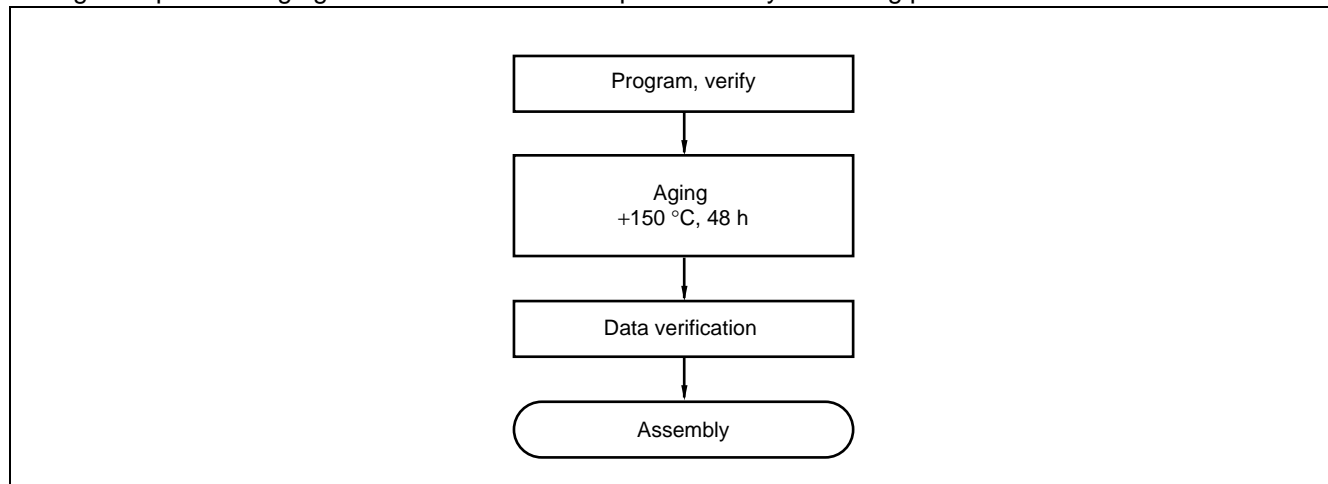

### 2. Programming Yield

Due to its nature, bit programming test can't be conducted as Fujitsu delivery test.  
For this reason, a programming yield of 100% cannot be assured at all times.

### 3. EPROM Programmer Socket Adapter

Part no.	Package	Compatible socket adapter Sun Hayato Co., Ltd.	Recommended programmer manufacturer and programmer name
			Minato Electronics Inc.
			1890A
MB89P131PF	QFP-48	ROM-48QF2-28DP-8L	Recommended
MB89P133APFM			—
MB89P133AP	SH-DIP-48	ROM-48SD-28DP-8L2	—

Inquiry : Sun Hayato Co., Ltd. : TEL (81) -3-3986-0403  
FAX (81) -3-5396-9106

Minato Electronics Inc. : TEL : USA (1) -916-348-6066  
JAPAN (81) -45-591-5611

# MB89130/130A Series

## PROGRAMMING TO THE EPROM WITH PIGGYBACK/EVALUATION DEVICE

### 1. EPROM for Use

MBM27C256A-20TVM

### 2. Programming Socket Adapter

To program to the PROM using an EPROM programmer, use the socket adapter (manufacturer : Sun Hayato Co., Ltd.) listed below :

Package	Socket adapter part number
LCC-32 (Square)	ROM-32LC-28DP-S

Inquiry : Sun Hayato Co., Ltd. : TEL (81) -3-3986-0403  
FAX (81) -3-5396-9106

### 3. Memory Space

Memory space in each mode, such as 32-Kbyte PROM is diagrammed below.

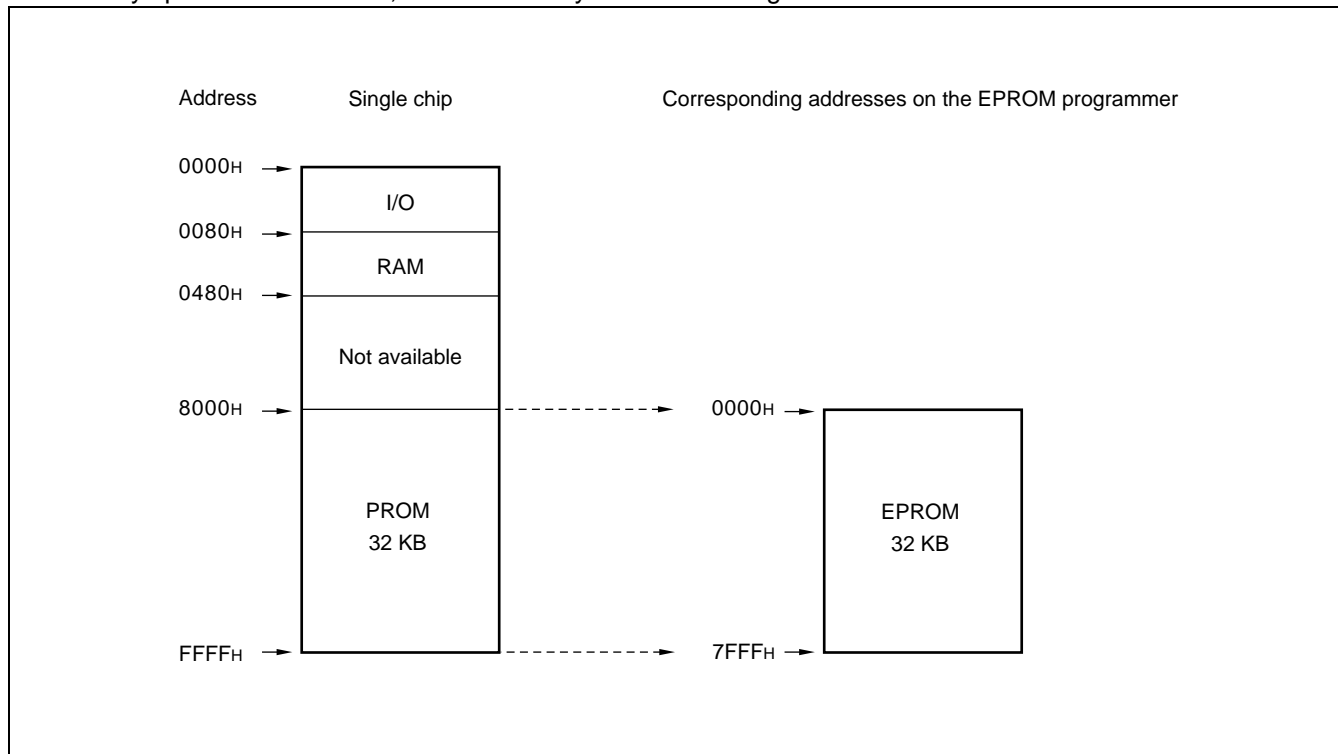

### 4. Programming to the EPROM

- (1) Set the EPROM programmer for the MBM27C256A.
- (2) Load program data into the EPROM programmer at 0000H to 7FFFH.
- (3) Program with the EPROM programmer.

## ■ BLOCK DIAGRAM

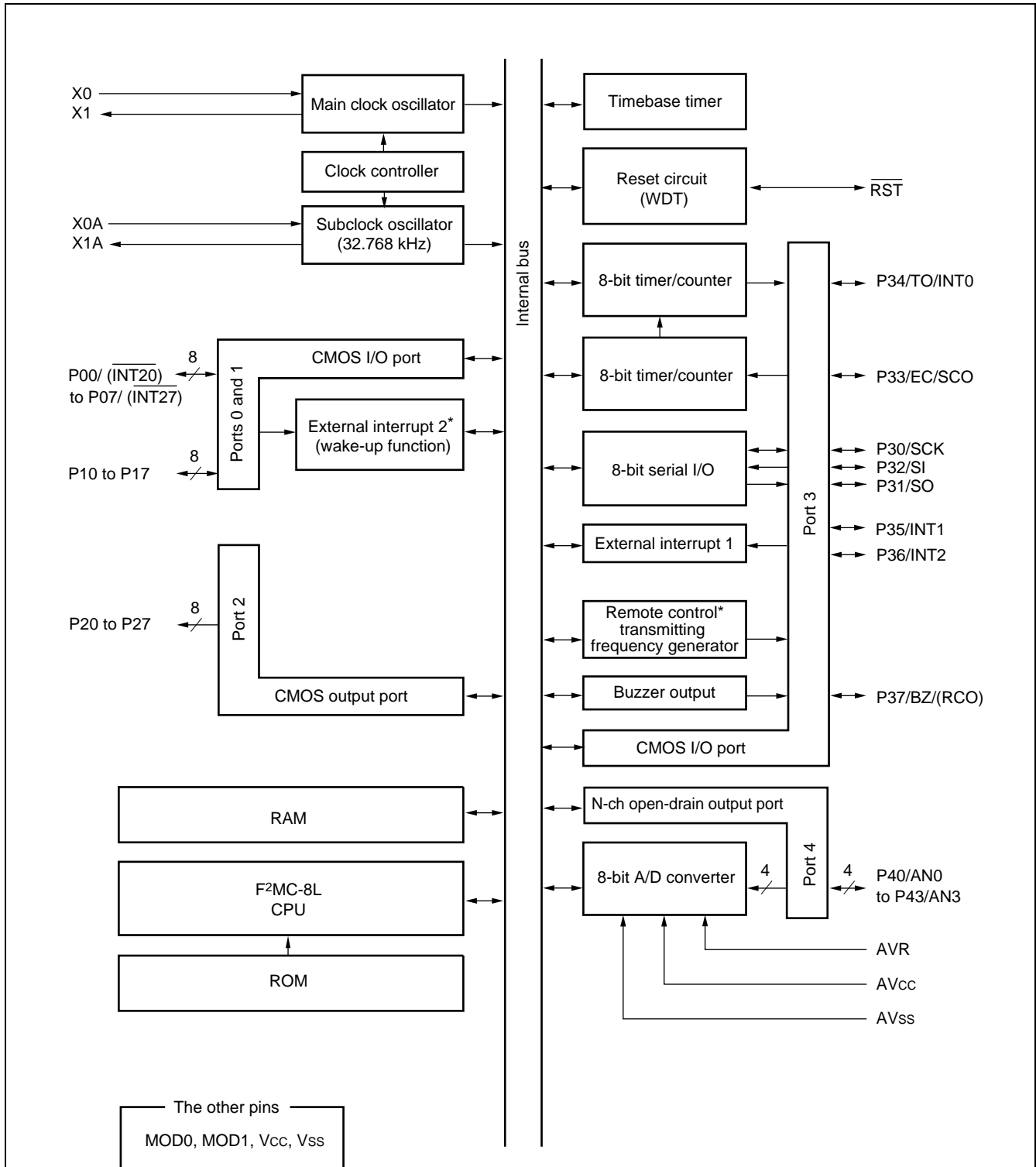

\* : Only for the MB89130A series.

Note : Parenthesized pin function is only for the MB89130A series.

# MB89130/130A Series

## ■ CPU CORE

### 1. Memory Space

The microcontrollers of the MB89130/130A series offer a memory space of 64 Kbytes for storing all of I/O, data, and program areas. The I/O area is allocated from the lowest address. The data area is allocated immediately above the I/O area. The data area can be divided into register, stack, and direct areas according to the application. The program area is allocated from exactly the opposite end, that is, near the highest address. The tables of interrupt reset vectors and vector call instructions are allocated from the highest address within the program area. The memory space of the MB89130/130A series is structured as illustrated below.

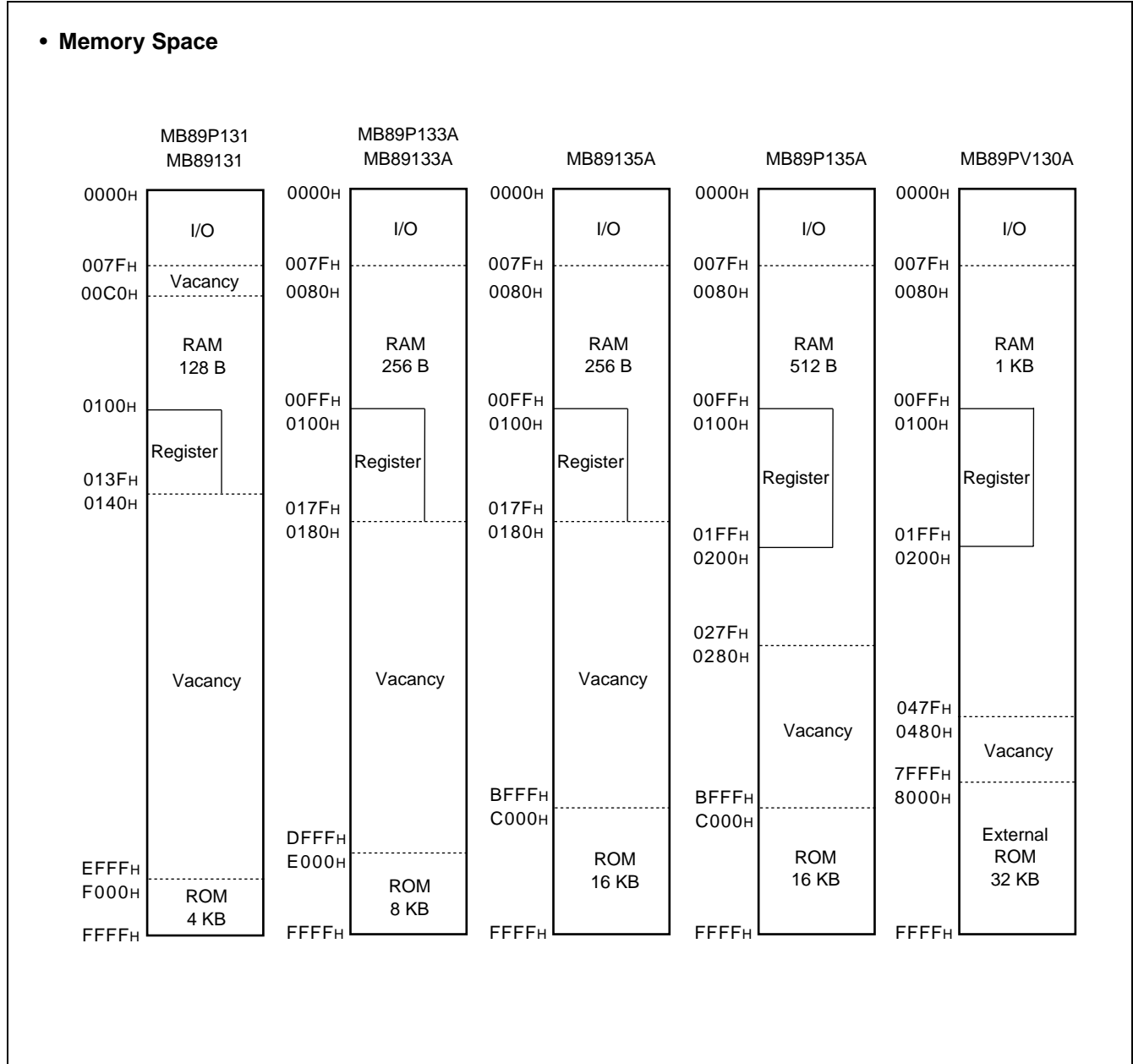

## 2. Registers

The F<sup>2</sup>MC-8L family has two types of registers; dedicated hardware registers in the CPU and general-purpose memory registers. The following registers are provided :

- Program counter (PC) : A 16-bit register for indicating the instruction storage positions.
- Accumulator (A) : A 16-bit temporary register for storing arithmetic operations, etc. When the instruction is an 8-bit data processing instruction, the lower byte is used.
- Temporary accumulator (T) : A 16-bit register which is used for arithmetic operations with the accumulator. When the instruction is an 8-bit data processing instruction, the lower byte is used.
- Index register (IX) : A 16-bit register for index modification
- Extra pointer (EP) : A 16-bit pointer for indicating a memory address
- Stack pointer (SP) : A 16-bit pointer for indicating a stack area
- Program status (PS) : A 16-bit register for storing a register pointer, a condition code

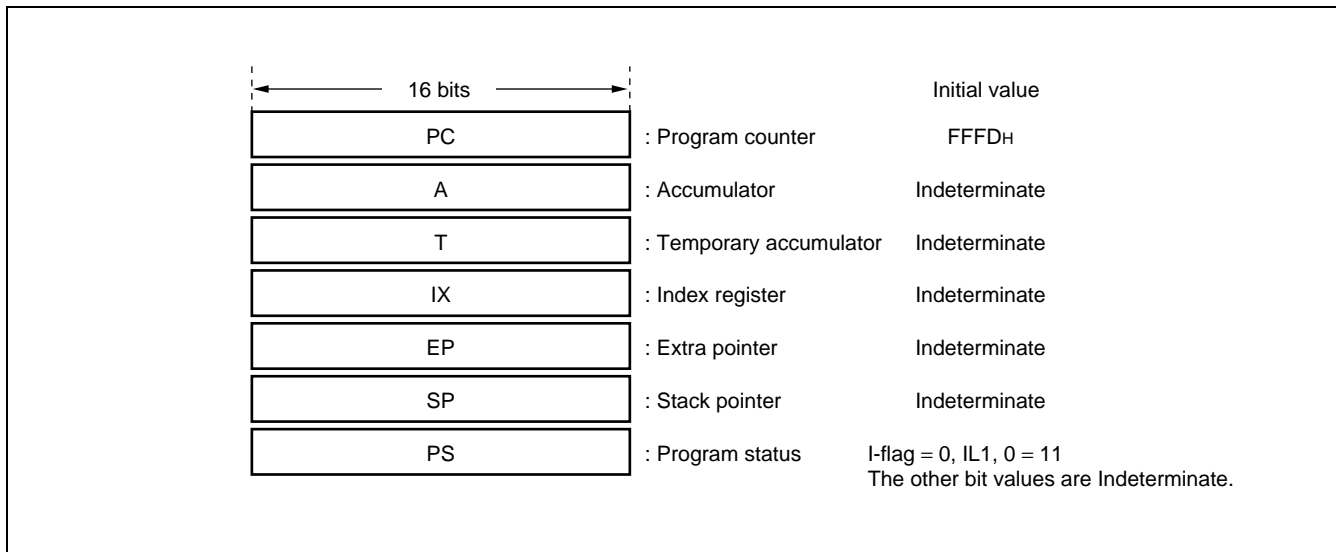

The PS can further be divided into higher 8 bits for use as a register bank pointer (RP) and the lower 8 bits for use as a condition code register (CCR) . (See the diagram below.)

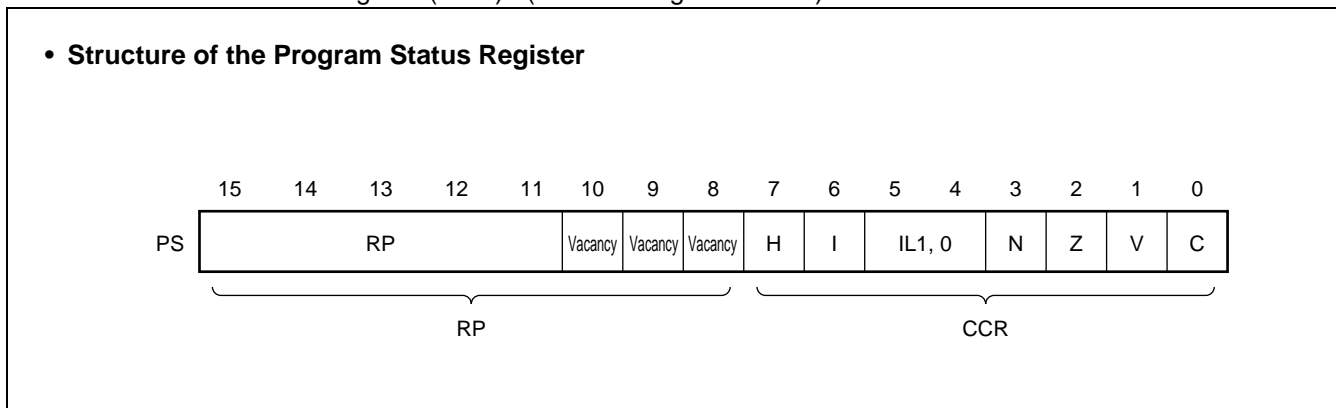

# MB89130/130A Series

The RP indicates the address of the register bank currently in use. The relationship between the pointer contents and the actual address is based on the conversion rule illustrated below.

• **Rule for Conversion of Actual Addresses of the General-purpose Register Area**

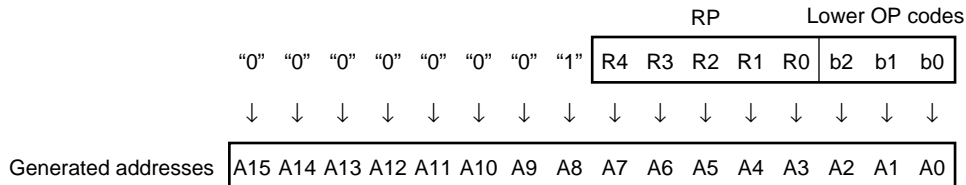

The CCR consists of bits indicating the results of arithmetic operations and the contents of transfer data, and bits for control of CPU operations at the time of an interrupt.

H-flag : Set to '1' when a carry or a borrow from bit 3 to bit 4 occurs as a result of an arithmetic operation. Cleared to '0' otherwise. This flag is for decimal adjustment instructions.

I-flag : Interrupt is enabled when this flag is set to '1'. Interrupt is disabled when the flag is cleared to '0'. Cleared to '0' at the reset.

IL1, 0 : Indicates the level of the interrupt currently allowed. Processes an interrupt only if its request level is higher than the value indicated by this bit.

IL1	ILO	Interrupt level	High-low
0	0	1	High
0	1		↓
1	0	2	
1	1	3	

N-flag : Set to '1' if the MSB becomes '1' as the result of an arithmetic operation. Cleared to '0' otherwise.

Z-flag : Set to '1' when an arithmetic operation results in '0'. Cleared to '0' otherwise.

V-flag : Set to '1' if the complement on '2' overflows as a result of an arithmetic operation. Cleared to '0' if the overflow does not occur.

C-flag : Set to '1' when a carry or a borrow from bit 7 occurs as a result of an arithmetic operation. Cleared to '0' otherwise.

Set to the shift-out value in the case of a shift instruction.



The following general-purpose registers are provided :

General-purpose registers : An 8-bit register for storing data

The general-purpose registers are of 8 bits and located in the register banks of the memory. One bank contains eight registers. Up to a total of 8 banks can be used on the MB89131/P131 and a total of 16 banks can be used on the MB89133A/P133A/135A and a total of 32 banks can be used on the MB89P135A/PV130A. The bank currently in use is indicated by the register bank pointer (RP) .

## • Register Bank Configuration

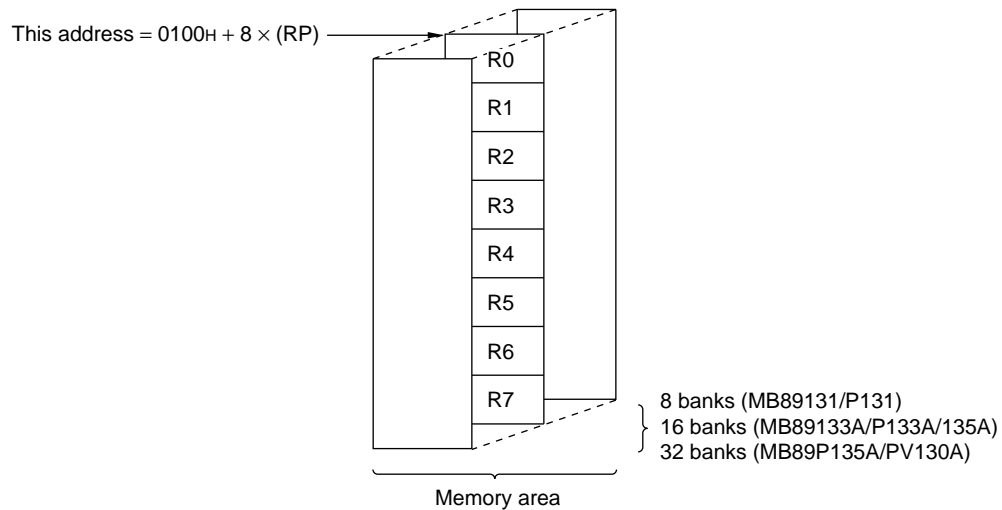

# MB89130/130A Series

## ■ I/O MAP

Address	Read/write	Register name	Register description
00 <sub>H</sub>	(R/W)	PDR0	Port 0 data register
01 <sub>H</sub>	(W)	DDR0	Port 0 data direction register
02 <sub>H</sub>	(R/W)	PDR1	Port 1 data register
03 <sub>H</sub>	(W)	DDR1	Port 1 data direction register
04 <sub>H</sub>	(R/W)	PDR2	Port 2 data register
05 <sub>H</sub>			Vacancy
06 <sub>H</sub>			Vacancy
07 <sub>H</sub>	(R/W)	SYCC	System clock control register
08 <sub>H</sub>	(R/W)	STBC	Standby control register
09 <sub>H</sub>	(R/W)	WDTC	Watchdog timer control register
0A <sub>H</sub>	(R/W)	TBTC	Timebase timer control register
0B <sub>H</sub>	(R/W)	WPCR	Watch prescaler control register
0C <sub>H</sub>	(R/W)	PDR3	Port 3 data register
0D <sub>H</sub>	(W)	DDR3	Port 3 data direction register
0E <sub>H</sub>	(R/W)	PDR4	Port 4 data register
0F <sub>H</sub>	(R/W)	BZCR	Buzzer register
10 <sub>H</sub>			Vacancy
11 <sub>H</sub>			Vacancy
12 <sub>H</sub>	(R/W)	SCGC	Peripheral control clock register
13 <sub>H</sub>			Vacancy
14 <sub>H</sub>	(R/W)	RCR1	Remote control transmitting control register 1*
15 <sub>H</sub>	(R/W)	RCR2	Remote control transmitting control register 2*
16 <sub>H</sub>			Vacancy
17 <sub>H</sub>			Vacancy
18 <sub>H</sub>	(R/W)	T2CR	Timer 2 control register
19 <sub>H</sub>	(R/W)	T1CR	Timer 1 control register
1A <sub>H</sub>	(R/W)	T2DR	Timer 2 data register
1B <sub>H</sub>	(R/W)	T1DR	Timer 1 data register
1C <sub>H</sub>	(R/W)	SMR	Serial mode register
1D <sub>H</sub>	(R/W)	SDR	Serial data register
1E <sub>H</sub>			Vacancy
1F <sub>H</sub>			Vacancy

(Continued)

# MB89130/130A Series

(Continued)

Address	Read/write	Register name	Register description
20 <sub>H</sub>	(R/W)	ADC1	A/D converter control register 1
21 <sub>H</sub>	(R/W)	ADC2	A/D converter control register 2
22 <sub>H</sub>	(R/W)	ADCD	A/D converter data register
23 <sub>H</sub>	(R/W)	EIC1	External interrupt 1 control register 1
24 <sub>H</sub>	(R/W)	EIC2	External interrupt 1 control register 2
25 <sub>H</sub>			Vacancy
26 <sub>H</sub> to 31 <sub>H</sub>			Vacancy
32 <sub>H</sub>	(R/W)	EIE2	External interrupt 2 enable register*
33 <sub>H</sub>	(R/W)	EIF2	External interrupt 2 flag register*
34 <sub>H</sub> to 7B <sub>H</sub>			Vacancy
7C <sub>H</sub>	(W)	ILR1	Interrupt level setting register 1
7D <sub>H</sub>	(W)	ILR2	Interrupt level setting register 2
7E <sub>H</sub>	(W)	ILR3	Interrupt level setting register 3
7F <sub>H</sub>			Vacancy

\* : Only for the MB89130A series

Note : Do not use vacancies.

# MB89130/130A Series

## ■ ELECTRICAL CHARACTERISTICS

### 1. Absolute Maximum Ratings

( $AV_{SS} = V_{SS} = 0.0\text{ V}$ )

Parameter	Symbol	Value		Unit	Remarks
		Min.	Max.		
Power supply voltage	$V_{CC}$ $AV_{CC}$	$V_{SS} - 0.3$	$V_{SS} + 7.2$	V	*
	AVR	$V_{SS} - 0.3$	$V_{SS} + 7.2$	V	AVR must not exceed $V_{CC} + 0.3\text{ V}$
Program voltage	$V_{PP}$	$V_{SS} - 0.6$	$V_{SS} + 13.0$	V	Only for the MB89P131/P133A/ P135A
Input voltage	$V_I$	$V_{SS} - 0.3$	$V_{CC} + 0.3$	V	
Output voltage	$V_O$	$V_{SS} - 0.3$	$V_{CC} + 0.3$	V	
"L" level maximum output current	$I_{OL}$	—	10	mA	
"L" level average output current	$I_{OLAV}$	—	4	mA	Average value (operating current × operating rate)
"L" level total maximum output current	$\Sigma I_{OL}$	—	100	mA	
"L" level total average output current	$\Sigma I_{OLAV}$	—	20	mA	Average value (operating current × operating rate)
"H" level maximum output current	$I_{OH}$	—	-10	mA	
"H" level average output current	$I_{OHAV}$	—	-2	mA	Average value (operating current × operating rate)
"H" level total maximum output current	$\Sigma I_{OH}$	—	-30	mA	
"H" level total average output current	$\Sigma I_{OHAV}$	—	-10	mA	Average value (operating current × operating rate)
Power consumption	$P_D$	—	200	mW	
Operating temperature	$T_A$	-40	+85	°C	
Storage temperature	$T_{stg}$	-55	+150	°C	

\* : Use  $AV_{CC}$  and  $V_{CC}$  set to the same voltage.

Take care so that  $AV_{CC}$  does not exceed  $V_{CC}$ , such as when power is turned on.

**WARNING:** Semiconductor devices can be permanently damaged by application of stress (voltage, current, temperature, etc.) in excess of absolute maximum ratings. Do not exceed these ratings.

## 2. Recommended Operating Conditions

( $V_{SS} = V_{SS} = 0.0\text{ V}$ )

Parameter	Symbol	Value		Unit	Remarks
		Min.	Max.		
Power supply voltage	$V_{CC}$ $AV_{CC}$	2.2*	6.0*	V	Normal operation assurance range* MB89131/133A/135A
		2.7*	6.0*	V	Normal operation assurance range* MB89P131/P133A/135A/PV130A
		1.5	6.0	V	Retains the RAM state in the stop mode
	AVR	2.0	$AV_{CC}$	V	
Operating temperature	$T_A$	-40	+85	°C	

\* : These values vary with the operating frequencies and the analog assurance range. See Figure 1 and 2, and "5. A/D Converter Electrical Characteristics."

**Figure 1 Operating Voltage vs. Main Clock Operating Frequency**  
(MB89P131/P133A/P135A/PV130A, and single-clock MB89131/133/133A/135/135A)

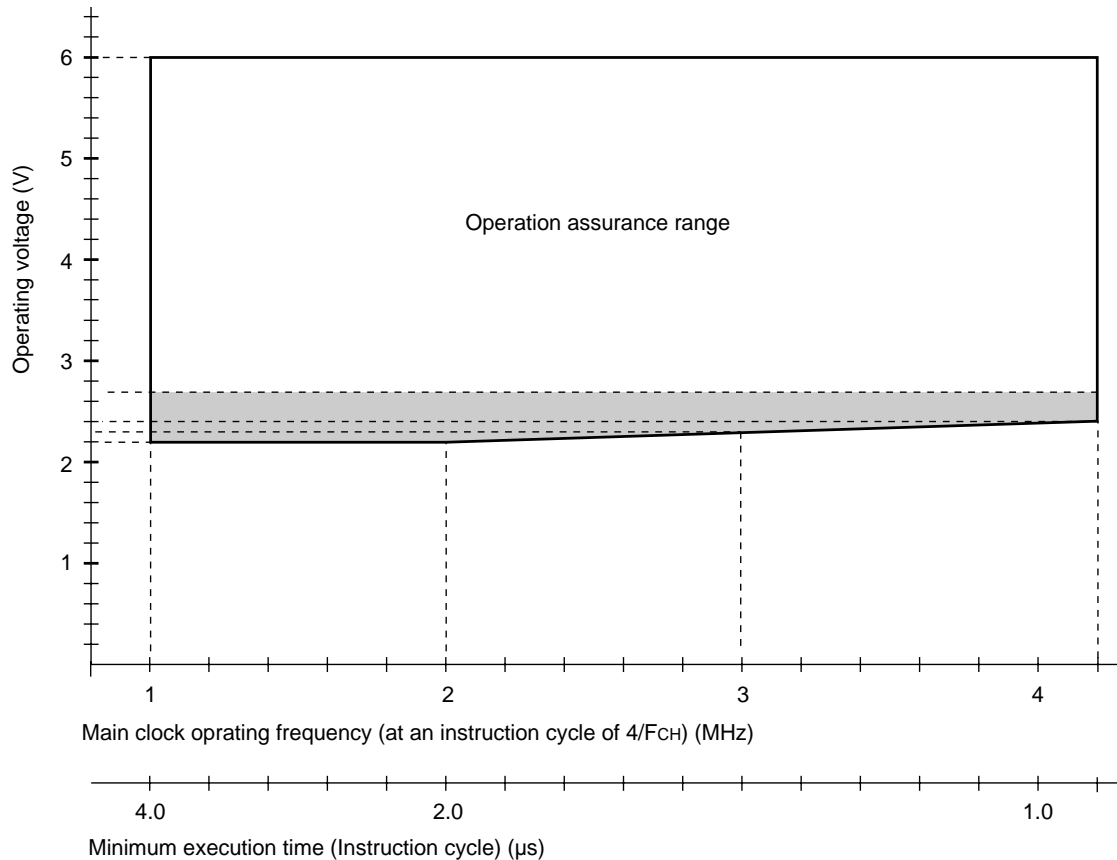

Note : The shaded area is assured only for the MB89131/133/133A/135/135A.

# MB89130/130A Series

**Figure 2 Operating Voltage vs. Main Clock Operating Frequency  
(Dual-clock MB89131/133/133A/135/135A)**

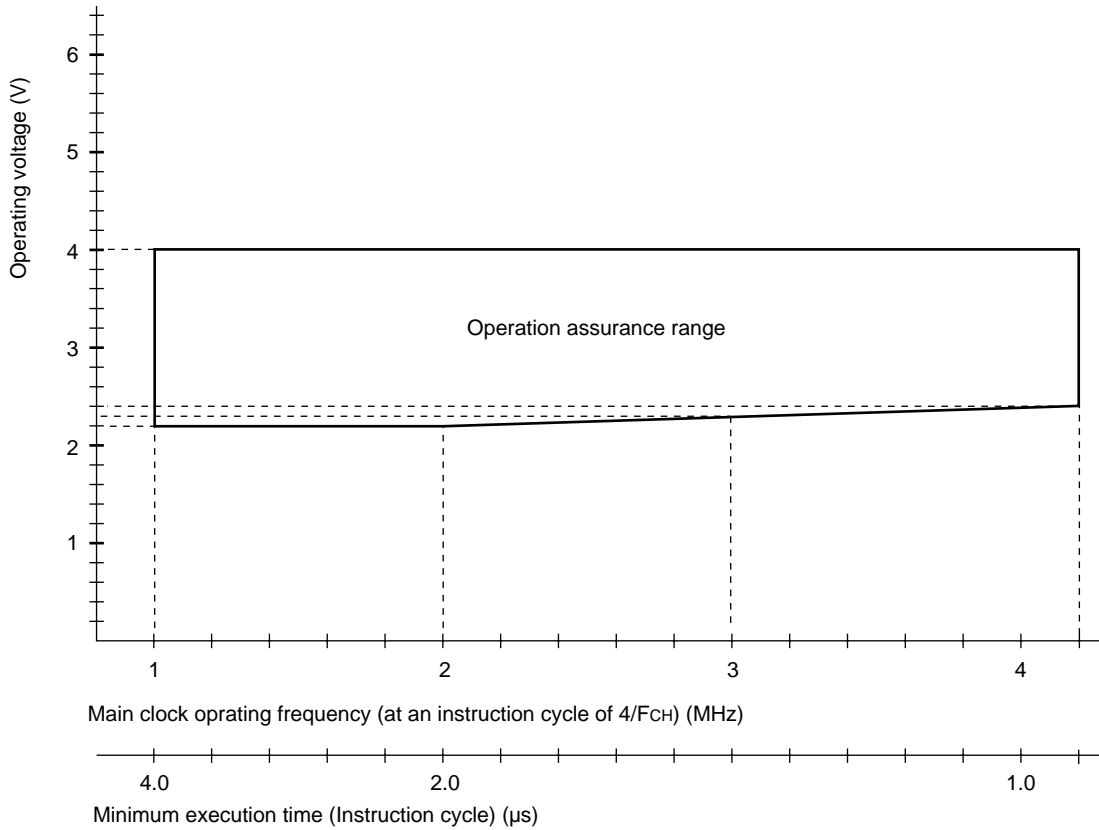

Figure 1 and 2 indicate the operating frequency of the external oscillator at an instruction cycle of  $4/F_{CH}$ . Since the operating voltage range is dependent on the instruction cycle, see minimum execution time if the operating speed is switched using a gear.

**WARNING:** The recommended operating conditions are required in order to ensure the normal operation of the semiconductor device. All of the device's electrical characteristics are warranted when the device is operated within these ranges.

Always use semiconductor devices within their recommended operating condition ranges. Operation outside these ranges may adversely affect reliability and could result in device failure.

No warranty is made with respect to uses, operating conditions, or combinations not represented on the data sheet. Users considering application outside the listed conditions are advised to contact their FUJITSU representatives beforehand.

# MB89130/130A Series

## 3. DC Characteristics

( $V_{CC} = V_{CC} = +5.0\text{ V}$ ,  $V_{SS} = V_{SS} = 0.0\text{ V}$ ,  $T_A = -40\text{ }^\circ\text{C}$  to  $+85\text{ }^\circ\text{C}$ )

Parameter	Symbol	Pin	Condition	Value			Unit	Remarks
				Min.	Typ.	Max.		
“H” level input voltage	$V_{IH}$	P00 to P07, P10 to P17	—	$0.7 V_{CC}$	—	$V_{CC} + 0.3$	V	
	$V_{IHS}$	$\overline{RST}$ , P30 to P37, $\overline{INT20}$ to $\overline{INT27}$		$0.8 V_{CC}$	—	$V_{CC} + 3.0$	V	$\overline{INT20}$ to $\overline{INT27}$ are available only for the MB89130A series.
“L” level input voltage	$V_{IL}$	P00 to P07, P10 to P17		$V_{SS} - 0.3$	—	$0.3 V_{CC}$	V	
	$V_{ILS}$	$\overline{RST}$ , P30 to P37, $\overline{INT20}$ to $\overline{INT27}$		$V_{SS} - 0.3$	—	$0.2 V_{CC}$	V	$\overline{INT20}$ to $\overline{INT27}$ are available only for the MB89130A series.
Open-drain output pin applied voltage	$V_D$	P40 to P43		$V_{CC} - 0.3$	—	$V_{CC} + 0.3$	V	
“H” level output voltage	$V_{OH}$	P00 to P07, P10 to P17, P20 to P27, P30 to P37	$I_{OH} = -2.0\text{ mA}$	2.4	—	—	V	
“L” level output voltage	$V_{OL}$	P00 to P07, P10 to P17, P20 to P27, P30 to P37, P40 to P43	$I_{OL} = 1.8\text{ mA}$	—	—	0.4	V	
	$V_{OL2}$	$\overline{RST}$	$I_{OL} = 4.0\text{ mA}$	—	—	0.6	V	
Input leakage current (Hi-z output leakage current)	$I_{LI1}$	P00 to P07, P10 to P17, P20 to P27, P30 to P37, P40 to P43, MOD0, MOD1	$0.0\text{ V} < V_I < V_{CC}$	—	—	$\pm 5$	$\mu\text{A}$	Without pull-up resistor
Pull-up resistance	$R_{PULL}$	P00 to P07, P10 to P17, P30 to P37, P40 to P43, $\overline{RST}$	$V_I = 0.0\text{ V}$	25	50	100	$\text{k}\Omega$	

(Continued)

# MB89130/130A Series

(Continued)

( $AV_{CC} = V_{CC} = +5.0$  V,  $AV_{SS} = V_{SS} = 0.0$  V,  $T_A = -40$  °C to  $+85$  °C)

Parameter	Symbol	Pin	Condition	Value			Unit	Remarks
				Min.	Typ.	Max.		
Power supply current <sup>*1</sup>	I <sub>CC1</sub>	V <sub>CC</sub> (External clock operation)	F <sub>CH</sub> = 4.00 MHz V <sub>CC</sub> = 5.0 V t <sub>inst</sub> <sup>*2</sup> = 1.0 μs	—	4	7	mA	MB89131/ 133A/135A
				—	6	10	mA	MB89P131/ P133A/P135A
	I <sub>CCS1</sub>		F <sub>CH</sub> = 4.00 MHz V <sub>CC</sub> = 5.0 V t <sub>inst</sub> <sup>*2</sup> = 1.0 μs Main clock sleep mode	—	2	5	mA	
	I <sub>CCL</sub>		F <sub>CL</sub> = 32.768 kHz V <sub>CC</sub> = 3.0 V Subclock mode	—	50	100	μA	MB89131/ 133A/135A
				—	1	3	mA	MB89P131/ P133A/P135A
	I <sub>CCLS</sub>		F <sub>CL</sub> = 32.768 kHz V <sub>CC</sub> = 3.0 V Subclock sleep mode	—	25	50	μA	
	I <sub>CCCT</sub>		F <sub>CL</sub> = 32.768 kHz V <sub>CC</sub> = 3.0 V • Watch mode • Main clock stop mode in dual-clock system	—	—	15	μA	
	I <sub>CCCH</sub>		T <sub>A</sub> = +25 °C • Subclock stop mode • Main clock stop mode in single-clock system	—	—	1	μA	
	I <sub>A</sub>		AV <sub>CC</sub>	F <sub>CH</sub> = 4 MHz, when A/D conversion is operating	—	1	3	mA
I <sub>AH</sub>	AV <sub>CC</sub>	F <sub>CH</sub> = 4 MHz, T <sub>A</sub> = +25 °C, when A/D conversion is not operating	—	—	1	μA		
Input capacitance	C <sub>IN</sub>	Other than AV <sub>CC</sub> , AV <sub>SS</sub> , V <sub>CC</sub> , and V <sub>SS</sub>	f = 1 MHz	—	10	—	pF	

\*1 : The power supply current is measured at the external clock.

\*2 : For information on t<sub>inst</sub>, see “ (4) Instruction Cycle” in “4. AC Characteristics.”



## 4. AC Characteristics

### (1) Reset Timing

( $V_{CC} = +5.0 \text{ V} \pm 10\%$ ,  $AV_{SS} = V_{SS} = 0.0 \text{ V}$ ,  $T_A = -40 \text{ }^\circ\text{C}$  to  $+85 \text{ }^\circ\text{C}$ )

Parameter	Symbol	Condition	Value		Unit	Remarks
			Min.	Max.		
$\overline{\text{RST}}$ "L" pulse width	$t_{\text{LZH}}$	—	$48 t_{\text{HCYL}}^*$	—	ns	

\* :  $t_{\text{HCYL}}$  is the oscillation cycle ( $1/F_{\text{CH}}$ ) to input to the X0 pin.

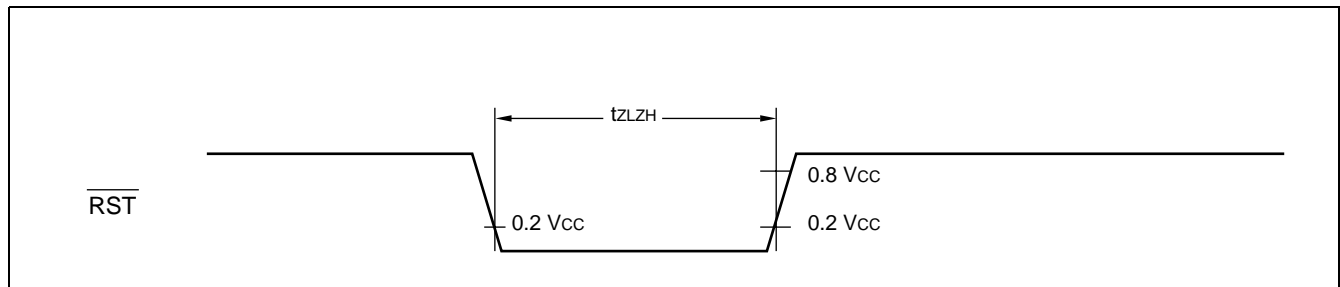

### (2) Power-on Reset

( $AV_{SS} = V_{SS} = 0.0 \text{ V}$ ,  $T_A = -40 \text{ }^\circ\text{C}$  to  $+85 \text{ }^\circ\text{C}$ )

Parameter	Symbol	Condition	Value		Unit	Remarks
			Min.	Max.		
Power supply rising time	$t_{\text{R}}$	—	—	50	ms	Power-on reset function only
Power supply cut-off time	$t_{\text{OFF}}$	—	1	—	ms	Due to repeated operations

Note : Make sure that power supply rises within the oscillation stabilization time selected.

For example, when the main clock is operating at 3 MHz ( $F_{\text{CH}}$ ) and the oscillation stabilization time selecting option has been set to  $2^{12}/F_{\text{CH}}$ , the oscillation stabilization time is 1.4 ms. Therefore, the maximum value of power supply rising time is about 1.4 ms.

Rapid changes in power supply voltage may cause a power-on reset. If power supply voltage needs to be varied in the course of operation, a smooth voltage rise is recommended.

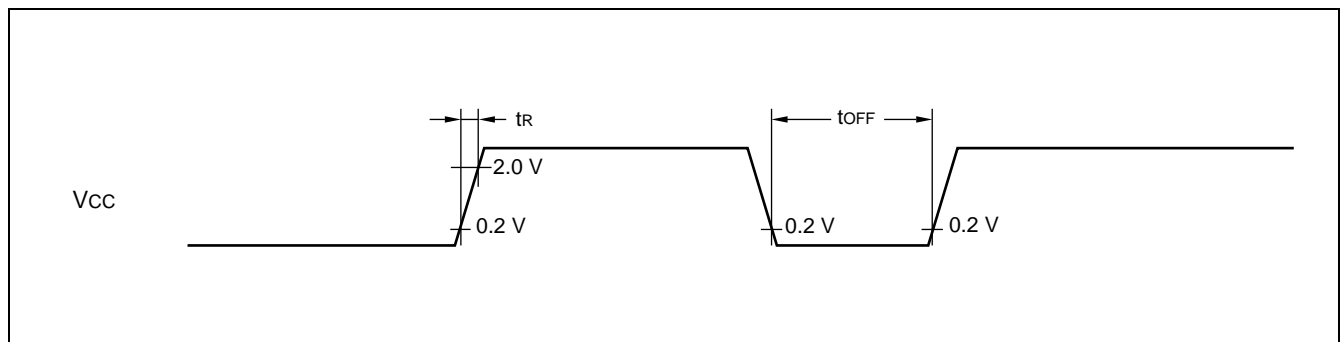

# MB89130/130A Series

## (3) Clock Timing

( $V_{SS} = 0.0 \text{ V}$ ,  $T_A = -40 \text{ }^\circ\text{C}$  to  $+85 \text{ }^\circ\text{C}$ )

Parameter	Symbol	Pin	Value			Unit	Remarks
			Min.	Typ.	Max.		
Input clock frequency	$F_{CH}$	X0, X1	1	—	4.2	MHz	Main clock
	$F_{CL}$	X0A, X1A	—	32.768	—	kHz	Subclock
Clock cycle time	$t_{HCYL}$	X0, X1	238	—	1000	ns	Main clock
	$t_{LCYL}$	X0A, X1A	—	30.5	—	$\mu\text{s}$	Subclock
Input clock pulse width	$P_{WH1}$ $P_{WL1}$	X0	30	—	—	ns	External clock
Input clock rising/falling time	$t_{CR1}$ $t_{CF1}$	X0	—	—	24	ns	External clock

### • X0 and X1 Timing and Conditions of Applied Voltage

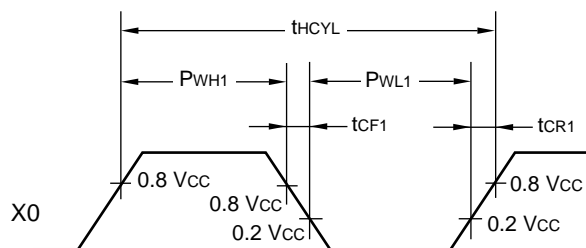

### • Main Clock Conditions

When a crystal or ceramic resonator is used

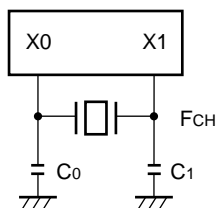

When an external clock is used

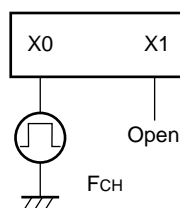

- X0A and X1A Timing and Conditions of Applied Voltage

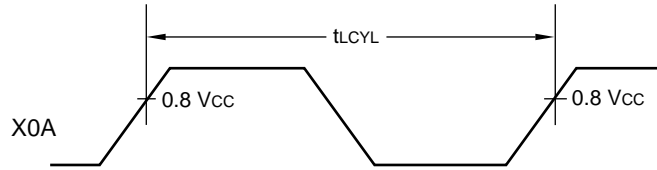

- Subclock Conditions

When a crystal or ceramic resonator is used

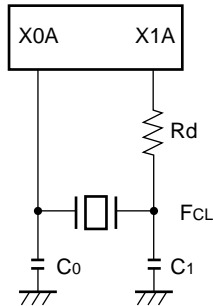

When a single-clock option is used

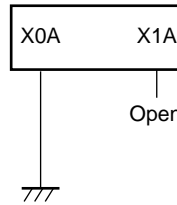

#### (4) Instruction Cycle

Parameter	Symbol	Value	Unit	Remarks
Instruction cycle (minimum execution time)	t <sub>inst</sub>	4/F <sub>CH</sub> , 8/F <sub>CH</sub> , 16/F <sub>CH</sub> , 64/F <sub>CH</sub>	μs	(4/F <sub>CH</sub> ) t <sub>inst</sub> = 1.0 μs when operating at F <sub>CH</sub> = 4 MHz
		2/F <sub>CL</sub>	μs	t <sub>inst</sub> = 61.036 μs when operating at F <sub>CL</sub> = 32.768 kHz

# MB89130/130A Series

## (5) Recommended Resonator Manufacturers

- Sample Application of Piezoelectric Resonator (FAR Family) for Main Clock Oscillation Circuit

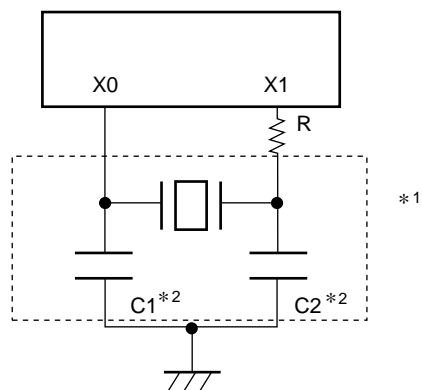

FAR part number*1 (built-in capacitor type)	Frequency (MHz)	Damping resistor	Initial deviation of FAR frequency (T <sub>A</sub> = +25 °C)	Temperature characteristics of FAR frequency (T <sub>A</sub> = -20 °C to +60 °C)	Loading capacitors*2
FAR-C4CC-02000-L00	2.00	1000 Ω	±0.5%	±0.5%	Built-in
FAR-C4□C-02000-□20		510 Ω	±0.5%	±0.5%	
FAR-C4□A-03000-□20	3.00	—	±0.5%	±0.5%	
FAR-C4□A-04000-□01	4.00	1 kΩ	±0.5%	±0.5%	
FAR-C4□A-04000-□21		750 Ω	±0.5%	±0.5%	
FAR-C4CB-04000-M00		—	±0.5%	±0.5%	
FAR-C4□B-04000-□00		—	±0.5%	±0.5%	
FAR-C4□B-04194-□00	4.194	—	±0.5%	±0.5%	

Inquiry : FUJITSU MEDIA DEVICES LIMITED

• Sample Application of Ceramic Resonator for Main Clock Oscillation Circuit

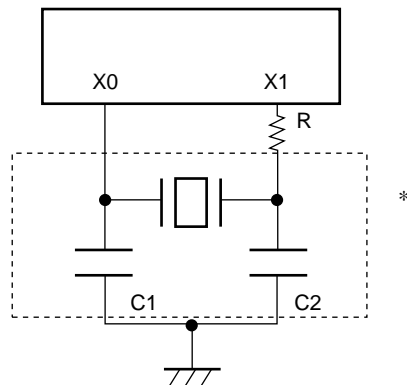

• Mask ROM products

Resonator manufacturer*	Resonator	Frequency (MHz)	C1 (pF)	C2 (pF)	R
Kyocera Corporation	KBR-4.0MKS	4.00	33	33	Not required
Matsushita Electronic Components Co., Ltd.	EFOV4004B	4.00	33 (Built-in)	33 (Built-in)	1.5 kΩ
Murata Mfg. Co., Ltd.	CSBF1000J	1.00	100	100	6.8 kΩ
	CSA4.00MG	4.00	30	30	Not required
	CSA4.00MGU		Built-in	Built-in	Not required
	CST4.00MGW		Built-in	Built-in	Not required
	CST4.00MGWU		Built-in	Built-in	Not required
	CST4.00MGWU040		Built-in	Built-in	Not required
	CST4.00MGWU040		Built-in	Built-in	Not required
	CSTCS4.00MG		Built-in	Built-in	Not required
	CSTCS4.00MGWOC5		Built-in	Built-in	Not required
TDK Corporation	CCR4.0MC3		4.00	Built-in	Built-in

(Continued)

# MB89130/130A Series

(Continued)

• **One-time PROM products**

Resonator manufacturer*	Resonator	Frequency (MHz)	C1 (pF)	C2 (pF)	R
Murata Mfg. Co., Ltd.	CSA3.00MG040	3.00	100	100	Not required
	CST3.00MGW040		Built-in	Built-in	Not required
	CSA4.00MG	4.00	30	30	Not required
	CSA4.00MGU		30	30	Not required
	CST4.00MGWU		Built-in	Built-in	Not required
	CSA4.00MGU040		100	100	Not required
	CST4.00MGWU040		Built-in	Built-in	Not required
CSTCS4.00MG	Built-in	Built-in	Not required		

Inquiry : Kyocera Corporation

- AVX Corporation  
North American Sales Headquarters : TEL 1-803-448-9411
- AVX Limited  
European Sales Headquarters : TEL 44-1252-770000
- AVX/Kyocera H.K. Ltd.  
Asian Sales Headquarters : TEL 852-363-3303

Matsushita Electronic Components Co., Ltd.

- North America  
Panasonic Industrial Co. : TEL 1-201-348-7000
- Canada  
Matsushita Electric of Canada Ltd. : TEL 905-238-2436
- Europe  
Panasonic Industrial Europe (Continental) : TEL 49-40-8549-2048  
Panasonic Industrial Europe (Niederlassung Munchen) : TEL 49-89-4800-7150
- Asia  
Panasonic Industry of Asia, Company : TEL 65-299-8400

Murata Mfg. Co., Ltd.

- Murata Electronics North America, Inc. : TEL 1-404-436-1300
- Murata Europe Management GmbH : TEL 49-911-66870
- Murata Electronics Singapore (Pte.) Ltd. : TEL 65-758-4233

TDK Corporation

- TDK Corporation of America  
Chicago Regional Office : TEL 1-708-803-6100
- TDK Electronics Europe GmbH  
Components Division : TEL 49-2102-9450
- TDK Singapore (PTE) Ltd. : TEL 65-273-5022
- TDK Hongkong Co., Ltd. : TEL 852-736-2238
- Korea Branch, TDK Corporation : TEL 82-2-554-6633

• Sample Application of Crystal Resonator for Subclock Oscillation Circuit

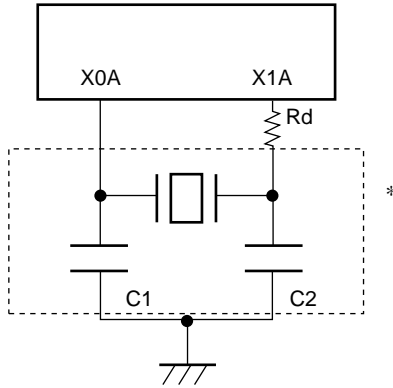

• Mask ROM products

Resonator manufacturer*	Resonator	Frequency (kHz)	C1 (pF)	C2 (pF)	Rd (kΩ)
SII	DS-VT-200	32.768	24	24	680

Inquiry : SII

- Seiko Instruments Inc. (Japan) : TEL 81-43-211-1219
- Seiko Instruments U.S.A. Inc. : TEL 310-517-7770
- Seiko Instruments GmbH : TEL 49-6102-297-122

(6) Serial I/O Timing

( $V_{CC} = +5.0\text{ V} \pm 10\%$ ,  $AV_{SS} = V_{SS} = 0.0\text{ V}$ ,  $T_A = -40\text{ }^\circ\text{C}$  to  $+85\text{ }^\circ\text{C}$ )

Parameter	Symbol	Pin	Condition	Value		Unit	Remarks
				Min.	Max.		
Serial clock cycle time	$t_{SCYC}$	SCK	Internal shift clock mode	$2 t_{inst}^*$	—	$\mu\text{s}$	
SCK $\downarrow \rightarrow$ SO time	$t_{SLOV}$	SCK, SO		-200	200	ns	
Valid SI $\rightarrow$ SCK $\uparrow$	$t_{IVSH}$	SI, SCK		200	—	ns	
SCK $\uparrow \rightarrow$ valid SI hold time	$t_{SHIX}$	SCK, SI		200	—	ns	
Serial clock "H" pulse width	$t_{SHSL}$	SCK	External shift clock mode	$1 t_{inst}^*$	—	$\mu\text{s}$	
Serial clock "L" pulse width	$t_{SLSH}$			$1 t_{inst}^*$	—	$\mu\text{s}$	
SCK $\downarrow \rightarrow$ SO time	$t_{SLOV}$	SCK, SO		0	200	ns	
Valid SI $\rightarrow$ SCK $\uparrow$	$t_{IVSH}$	SI, SCK		200	—	ns	
SCK $\uparrow \rightarrow$ valid SI hold time	$t_{SHIX}$	SCK, SI		200	—	ns	

\* : For information on  $t_{inst}$ , see "(4) Instruction Cycle."

# MB89130/130A Series

## • Internal Shift Clock Mode

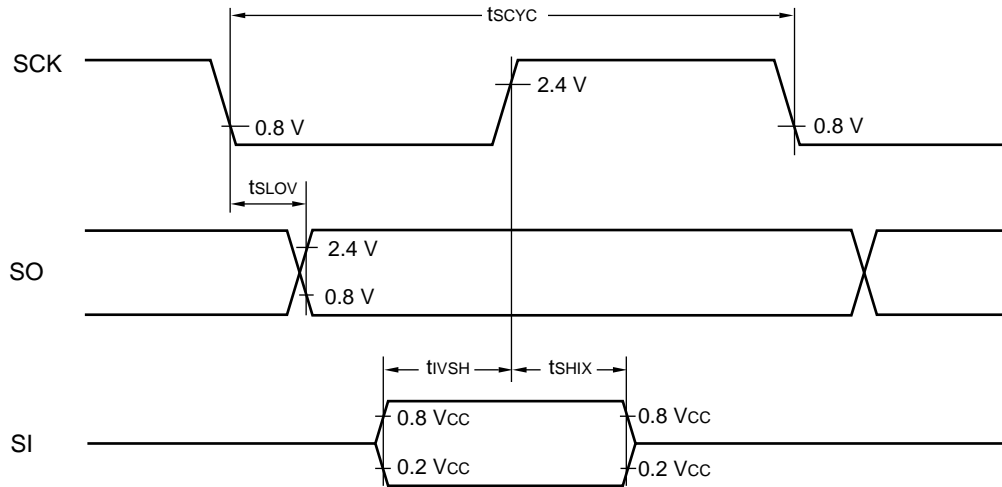

## • External Shift Clock Mode

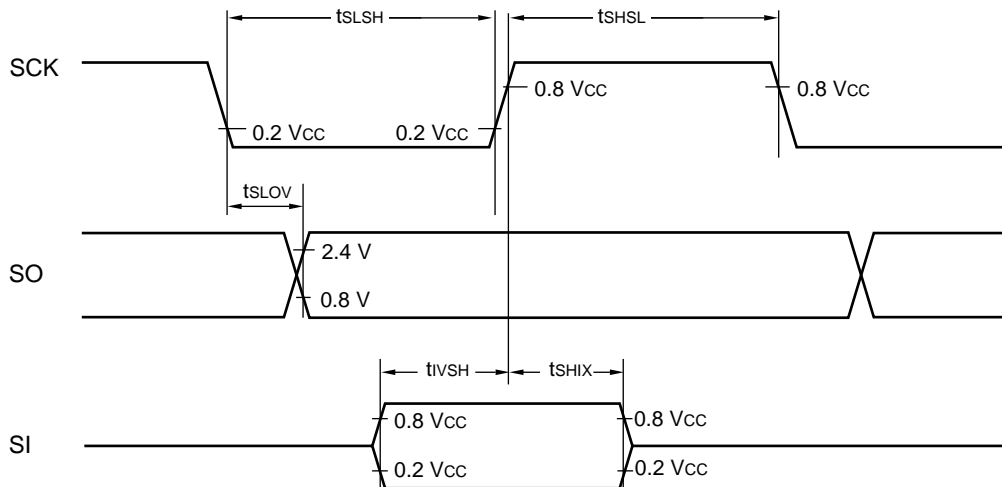



## (7) Peripheral Input Timing

( $V_{CC} = +5.0\text{ V} \pm 10\%$ ,  $AV_{SS} = V_{SS} = 0.0\text{ V}$ ,  $T_A = -40\text{ }^\circ\text{C}$  to  $+85\text{ }^\circ\text{C}$ )

Parameter	Symbol	Pin	Condition	Value		Unit	Remarks
				Min.	Max.		
Peripheral input "H" level pulse width 1	$t_{LH1}$	EC, INT0 to INT2	—	$2 t_{inst}^*$	—	$\mu\text{s}$	
Peripheral input "L" level pulse width 1	$t_{HL1}$			$2 t_{inst}^*$	—	$\mu\text{s}$	

\* : For information on  $t_{inst}$ , see "(4) Instruction Cycle."

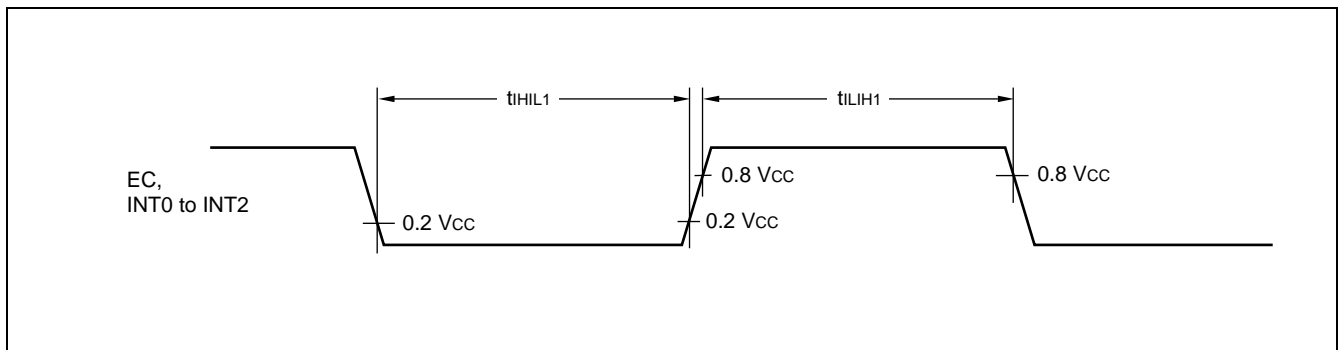

# MB89130/130A Series

## 5. A/D Converter Electrical Characteristics

( $AV_{CC} = V_{CC} = +3.5\text{ V to }+6.0\text{ V}$ ,  $F_{CH} = 3\text{ MHz}$ ,  $AV_{SS} = V_{SS} = 0.0\text{ V}$ ,  $T_A = -40\text{ }^\circ\text{C to }+85\text{ }^\circ\text{C}$ )

Parameter	Symbol	Pin	Condition	Value			Unit	Re- marks
				Min.	Typ.	Max.		
Resolution	—	—	$AVR = AV_{CC} = 5.0\text{ V}$	—	—	8	bit	
Total error			—	—	$\pm 1.5$	LSB		
Linearity error			—	—	$\pm 1.0$	LSB		
Differential linearity error			—	—	$\pm 0.9$	LSB		
Zero transition voltage	$V_{OT}$	—	$AVR = AV_{CC}$	$AV_{SS} - 1.0\text{ LSB}$	$AV_{SS} + 0.5\text{ LSB}$	$AV_{SS} + 2.0\text{ LSB}$	mV	1LSB = AVR/256
Full-scale transition voltage	$V_{FST}$			$AVR - 3.0\text{ LSB}$	$AVR - 1.5\text{ LSB}$	AVR	mV	
Interchannel disparity	—			—	—	0.5	LSB	
A/D mode conversion time	—	—	—	—	$44\ t_{inst}^*$	—	$\mu\text{s}$	
Sense mode conversion time	—			—	$12\ t_{inst}^*$	—	$\mu\text{s}$	
Analog port input current	$I_{AIN}$	AN0 to AN3	—	—	—	10	$\mu\text{A}$	
Analog input voltage	—	—	—	0	—	AVR	V	
Reference voltage	—	—	—	2.0	—	$AV_{CC}$	V	
Reference voltage supply current	$I_R$	AVR	$AVR = AV_{CC} = 5.0\text{ V}$ , when A/D conversion is operating	—	100	300	$\mu\text{A}$	
	$I_{RH}$		$AVR = AV_{CC} = 5.0\text{ V}$ , when A/D conversion is not operating	—	—	1	$\mu\text{A}$	

\* : For information on  $t_{inst}$ , see “(4) Instruction Cycle” in “4. AC Characteristics.”

## 6. A/D Converter Glossary

- Resolution

Analog changes that are identifiable by the A/D converter.

When the number of bits is 8, analog voltage can be divided into  $2^8 = 256$ .

- Linearity error (unit : LSB)

The deviation of the straight line connecting the zero transition point (“0000 0000” ↔ “0000 0001”) with the full-scale transition point (“1111 1111” ↔ “1111 1110”) from actual conversion characteristics

- Differential linearity error (unit : LSB)

The deviation of input voltage needed to change the output code by 1 LSB from the theoretical value

- Total error (unit : LSB)

The difference between theoretical and actual conversion values

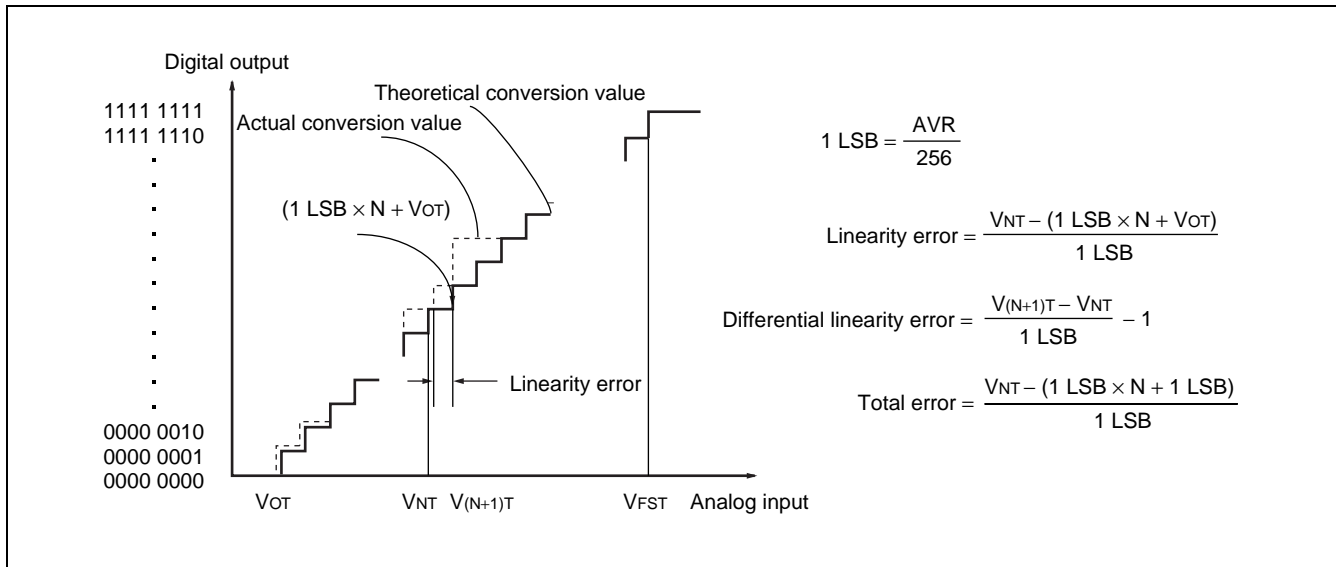

# MB89130/130A Series

## 7. Notes on Using A/D Converter

### • Input impedance of the analog input pins

The A/D converter used for the MB89130/130A series contains a sample hold circuit as illustrated below to fetch analog input voltage into the sample hold capacitor for eight instruction cycles after starting A/D conversion.

For this reason, if the output impedance of the external circuit for the analog input is high, analog input voltage might not stabilize within the analog input sampling period. Therefore, it is recommended to keep the output impedance of the external circuit low (below 10 k $\Omega$ ) .

Note that if the impedance cannot be kept low, it is recommended to connect an external capacitor of approx. 0.1  $\mu$ F for the analog input pin.

### • Analog Input Equivalent Circuit

If the analog input impedance is higher than 10 k $\Omega$ , it is recommended to connect an external capacitor of approx. 0.1  $\mu$ F.

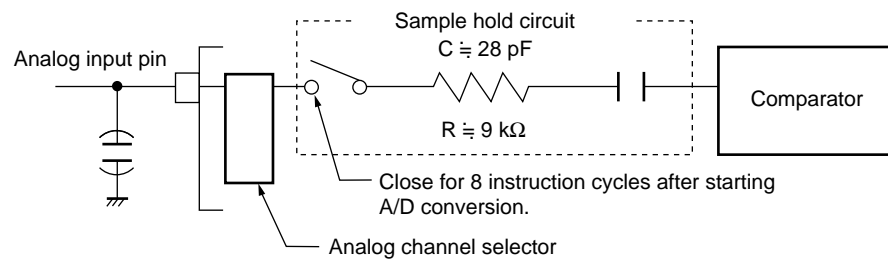

### • Error

The smaller the  $|AVR - AV_{SS}|$ , the greater the error would become relatively.

## EXAMPLE CHARACTERISTICS

(1) "L" Level Output Voltage

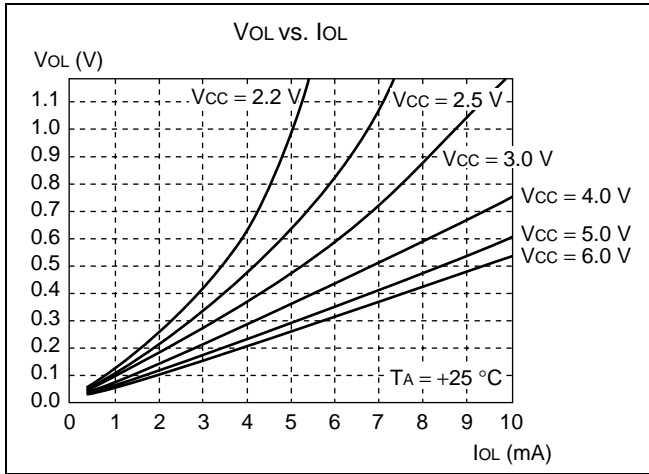

(2) "H" Level Output Voltage

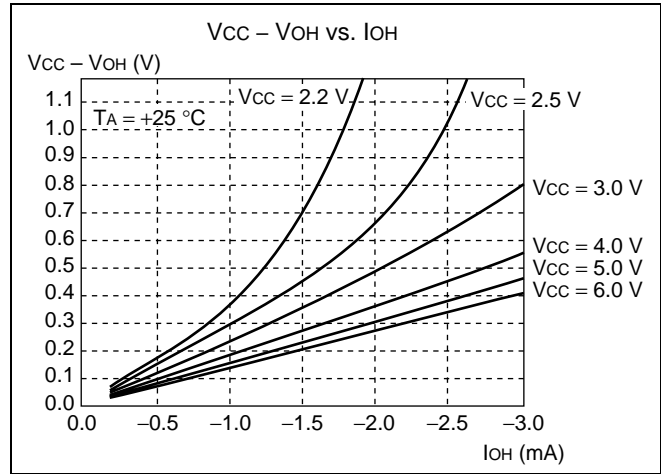

(3) "H" Level Input Voltage/"L" Level Input Voltage (CMOS Input)

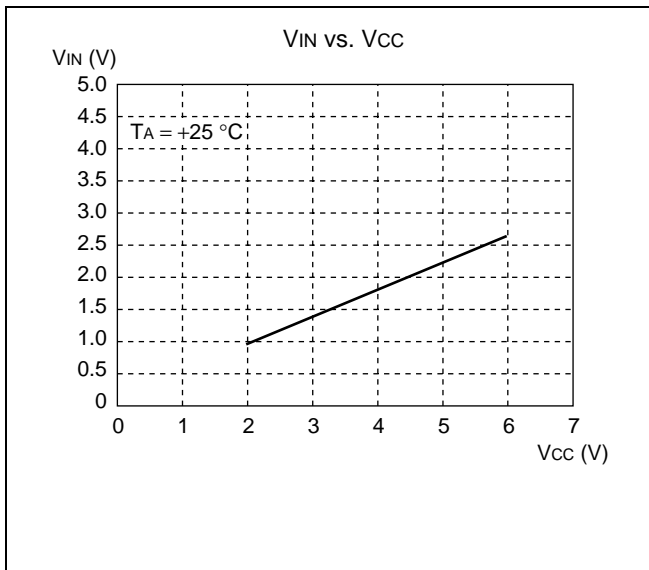

(4) "H" Level Input Voltage/"L" Level Input Voltage (Hysteresis Input)

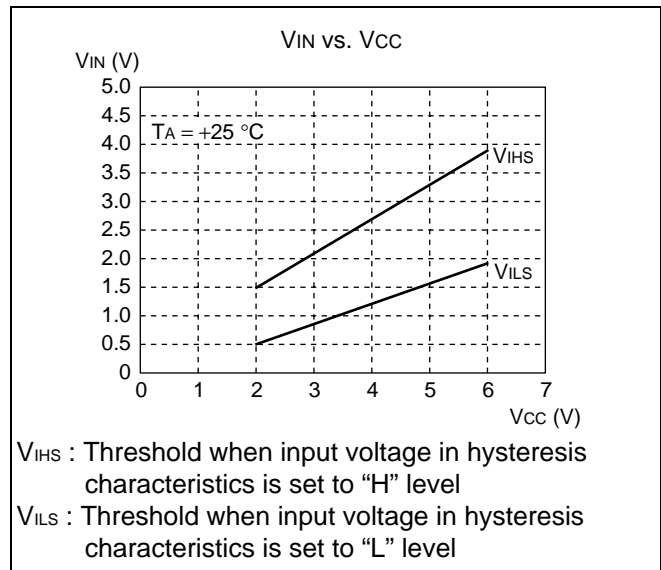

(5) Pull-up Resistance

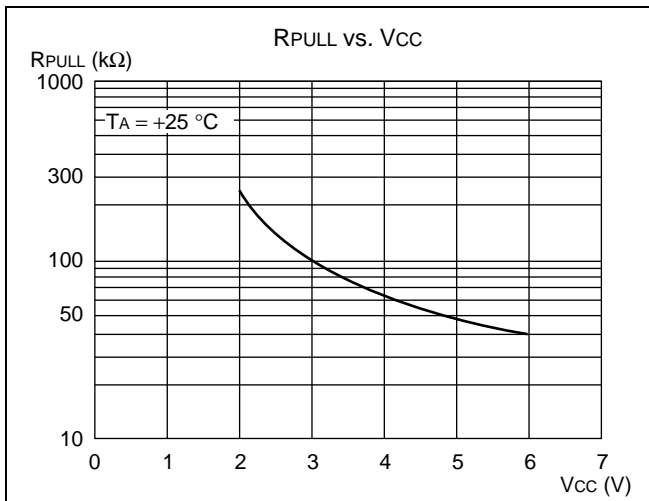

# MB89130/130A Series

## (6) Power Supply Current (External Clock)

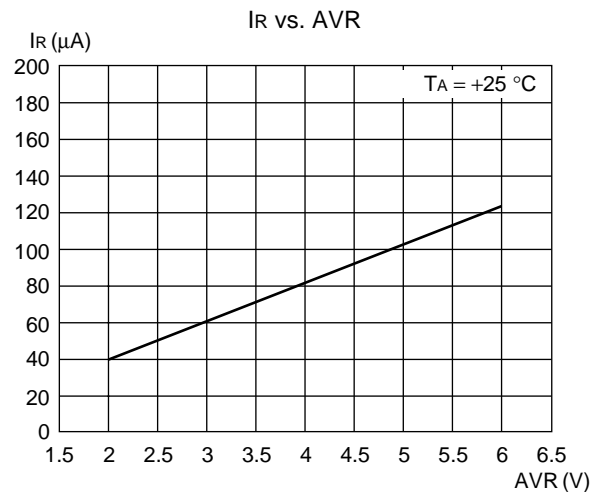
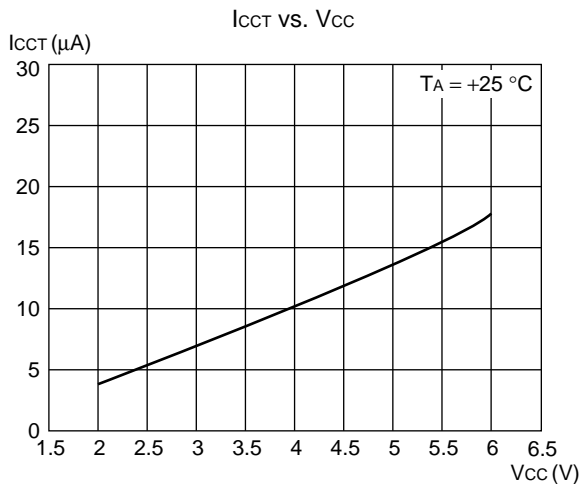
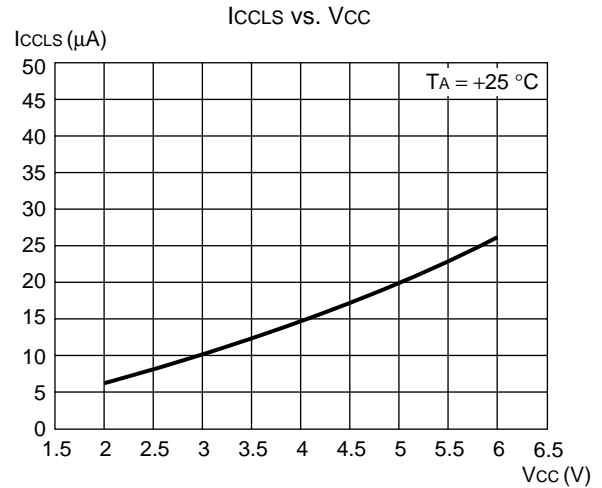
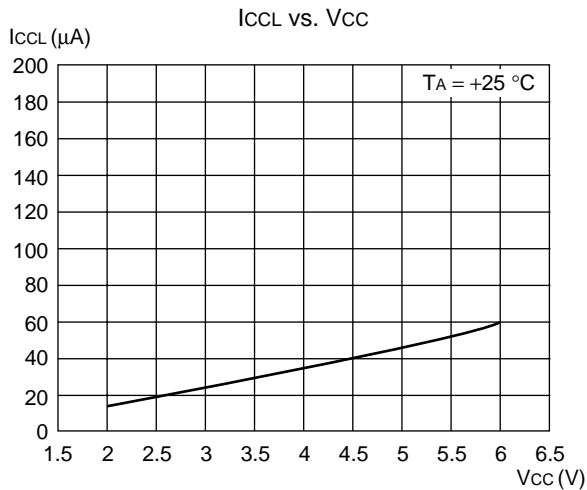
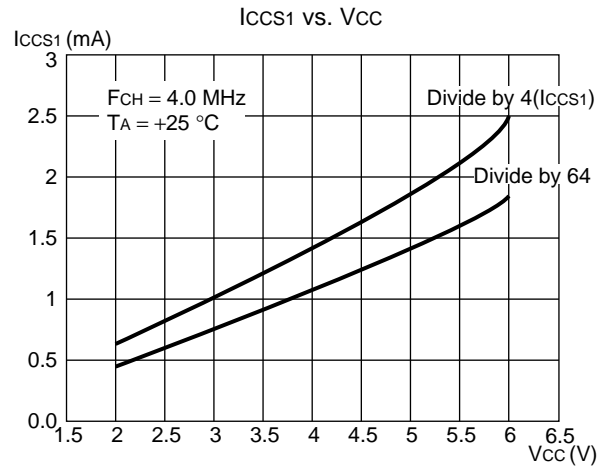
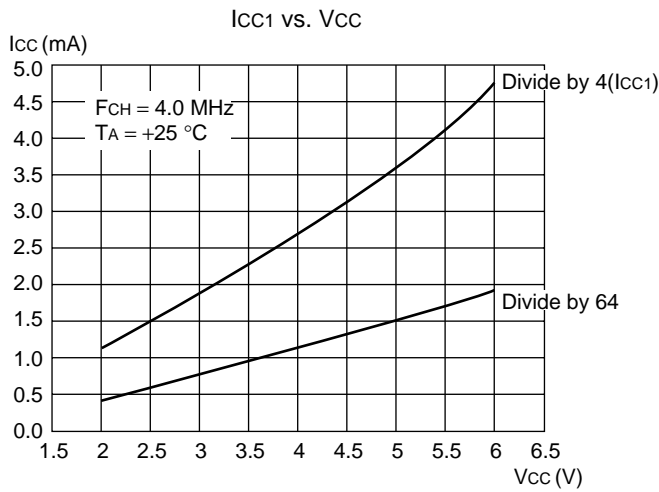

(Continued)

# MB89130/130A Series

(Continued)

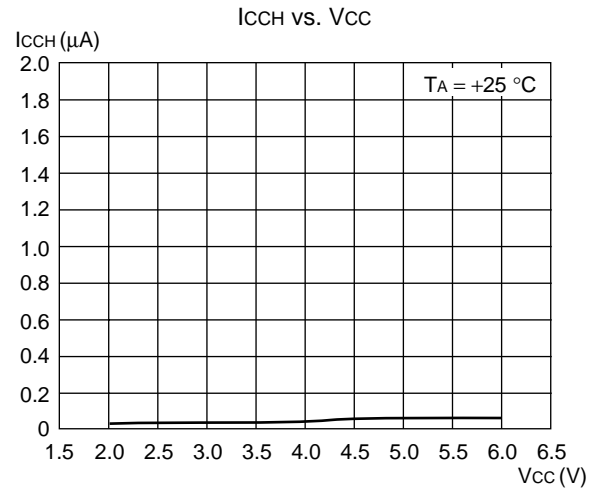
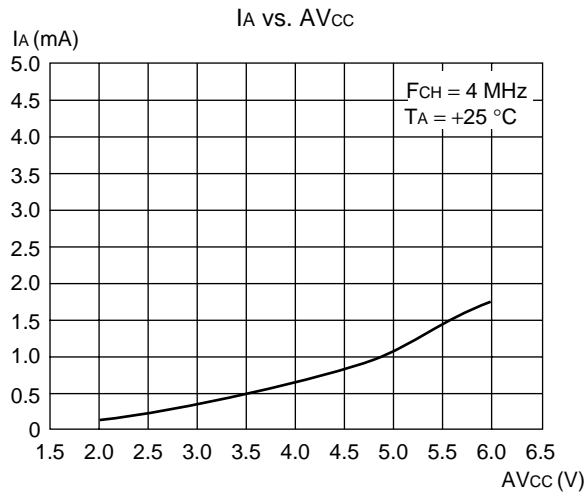

# MB89130/130A Series

## ■ INSTRUCTIONS (136 INSTRUCTIONS)

Execution instructions can be divided into the following four groups:

- Transfer
- Arithmetic operation
- Branch
- Others

Table 1 lists symbols used for notation of instructions.

**Table 1 Instruction Symbols**

Symbol	Meaning
dir	Direct address (8 bits)
off	Offset (8 bits)
ext	Extended address (16 bits)
#vct	Vector table number (3 bits)
#d8	Immediate data (8 bits)
#d16	Immediate data (16 bits)
dir: b	Bit direct address (8:3 bits)
rel	Branch relative address (8 bits)
@	Register indirect (Example: @A, @IX, @EP)
A	Accumulator A (Whether its length is 8 or 16 bits is determined by the instruction in use.)
AH	Upper 8 bits of accumulator A (8 bits)
AL	Lower 8 bits of accumulator A (8 bits)
T	Temporary accumulator T (Whether its length is 8 or 16 bits is determined by the instruction in use.)
TH	Upper 8 bits of temporary accumulator T (8 bits)
TL	Lower 8 bits of temporary accumulator T (8 bits)
IX	Index register IX (16 bits)
EP	Extra pointer EP (16 bits)
PC	Program counter PC (16 bits)
SP	Stack pointer SP (16 bits)
PS	Program status PS (16 bits)
dr	Accumulator A or index register IX (16 bits)
CCR	Condition code register CCR (8 bits)
RP	Register bank pointer RP (5 bits)
Ri	General-purpose register Ri (8 bits, i = 0 to 7)
×	Indicates that the very × is the immediate data. (Whether its length is 8 or 16 bits is determined by the instruction in use.)
(×)	Indicates that the contents of × is the target of accessing. (Whether its length is 8 or 16 bits is determined by the instruction in use.)
((×))	The address indicated by the contents of × is the target of accessing. (Whether its length is 8 or 16 bits is determined by the instruction in use.)

Columns indicate the following:

Mnemonic: Assembler notation of an instruction

~: The number of instructions

#: The number of bytes

Operation: Operation of an instruction

TL, TH, AH: A content change when each of the TL, TH, and AH instructions is executed. Symbols in the column indicate the following:

- “—” indicates no change.
- dH is the 8 upper bits of operation description data.
- AL and AH must become the contents of AL and AH prior to the instruction executed.
- 00 becomes 00.

N, Z, V, C: An instruction of which the corresponding flag will change. If + is written in this column, the relevant instruction will change its corresponding flag.

OP code: Code of an instruction. If an instruction is more than one code, it is written according to the following rule:  
Example: 48 to 4F ← This indicates 48, 49, ... 4F.



**Table 2 Transfer Instructions (48 instructions)**

Mnemonic	~	#	Operation	TL	TH	AH	NZVC	OP code
MOV dir,A	3	2	(dir) ← (A)	-	-	-	-----	45
MOV @IX +off,A	4	2	((IX) +off) ← (A)	-	-	-	-----	46
MOV ext,A	4	3	(ext) ← (A)	-	-	-	-----	61
MOV @EP,A	3	1	((EP)) ← (A)	-	-	-	-----	47
MOV Ri,A	3	1	(Ri) ← (A)	-	-	-	-----	48 to 4F
MOV A,#d8	2	2	(A) ← d8	AL	-	-	++--	04
MOV A,dir	3	2	(A) ← (dir)	AL	-	-	++--	05
MOV A,@IX +off	4	2	(A) ← ((IX) +off)	AL	-	-	++--	06
MOV A,ext	4	3	(A) ← (ext)	AL	-	-	++--	60
MOV A,@A	3	1	(A) ← ((A))	AL	-	-	++--	92
MOV A,@EP	3	1	(A) ← ((EP))	AL	-	-	++--	07
MOV A,Ri	3	1	(A) ← (Ri)	AL	-	-	++--	08 to 0F
MOV dir,#d8	4	3	(dir) ← d8	-	-	-	-----	85
MOV @IX +off,#d8	5	3	((IX) +off) ← d8	-	-	-	-----	86
MOV @EP,#d8	4	2	((EP)) ← d8	-	-	-	-----	87
MOV Ri,#d8	4	2	(Ri) ← d8	-	-	-	-----	88 to 8F
MOVW dir,A	4	2	(dir) ← (AH),(dir + 1) ← (AL)	-	-	-	-----	D5
MOVW @IX +off,A	5	2	((IX) +off) ← (AH), ((IX) +off + 1) ← (AL)	-	-	-	-----	D6
MOVW ext,A	5	3	(ext) ← (AH), (ext + 1) ← (AL)	-	-	-	-----	D4
MOVW @EP,A	4	1	((EP)) ← (AH),(EP) + 1) ← (AL)	-	-	-	-----	D7
MOVW EP,A	2	1	(EP) ← (A)	-	-	-	-----	E3
MOVW A,#d16	3	3	(A) ← d16	AL	AH	dH	++--	E4
MOVW A,dir	4	2	(AH) ← (dir), (AL) ← (dir + 1)	AL	AH	dH	++--	C5
MOVW A,@IX +off	5	2	(AH) ← ((IX) +off), (AL) ← ((IX) +off + 1)	AL	AH	dH	++--	C6
MOVW A,ext	5	3	(AH) ← (ext), (AL) ← (ext + 1)	AL	AH	dH	++--	C4
MOVW A,@A	4	1	(AH) ← ((A)), (AL) ← ((A) + 1)	AL	AH	dH	++--	93
MOVW A,@EP	4	1	(AH) ← ((EP)), (AL) ← ((EP) + 1)	AL	AH	dH	++--	C7
MOVW A,EP	2	1	(A) ← (EP)	-	-	dH	-----	F3
MOVW EP,#d16	3	3	(EP) ← d16	-	-	-	-----	E7
MOVW IX,A	2	1	(IX) ← (A)	-	-	-	-----	E2
MOVW A,IX	2	1	(A) ← (IX)	-	-	dH	-----	F2
MOVW SP,A	2	1	(SP) ← (A)	-	-	-	-----	E1
MOVW A,SP	2	1	(A) ← (SP)	-	-	dH	-----	F1
MOV @A,T	3	1	((A)) ← (T)	-	-	-	-----	82
MOVW @A,T	4	1	((A)) ← (TH),(A) + 1) ← (TL)	-	-	-	-----	83
MOVW IX,#d16	3	3	(IX) ← d16	-	-	-	-----	E6
MOVW A,PS	2	1	(A) ← (PS)	-	-	dH	-----	70
MOVW PS,A	2	1	(PS) ← (A)	-	-	-	++++	71
MOVW SP,#d16	3	3	(SP) ← d16	-	-	-	-----	E5
SWAP	2	1	(AH) ↔ (AL)	-	-	AL	-----	10
SETB dir: b	4	2	(dir): b ← 1	-	-	-	-----	A8 to AF
CLRB dir: b	4	2	(dir): b ← 0	-	-	-	-----	A0 to A7
XCH A,T	2	1	(AL) ↔ (TL)	AL	-	-	-----	42
XCHW A,T	3	1	(A) ↔ (T)	AL	AH	dH	-----	43
XCHW A,EP	3	1	(A) ↔ (EP)	-	-	dH	-----	F7
XCHW A,IX	3	1	(A) ↔ (IX)	-	-	dH	-----	F6
XCHW A,SP	3	1	(A) ↔ (SP)	-	-	dH	-----	F5
MOVW A,PC	2	1	(A) ← (PC)	-	-	dH	-----	F0

Note: During byte transfer to A, T ← A is restricted to low bytes.

Operands in more than one operand instruction must be stored in the order in which their mnemonics are written. (Reverse arrangement of F<sup>2</sup>MC-8 family)

# MB89130/130A Series

Table 3 Arithmetic Operation Instructions (62 instructions)

Mnemonic	~	#	Operation	TL	TH	AH	NZVC	OP code
ADDC A,Ri	3	1	$(A) \leftarrow (A) + (Ri) + C$	-	-	-	++++	28 to 2F
ADDC A,#d8	2	2	$(A) \leftarrow (A) + d8 + C$	-	-	-	++++	24
ADDC A,dir	3	2	$(A) \leftarrow (A) + (dir) + C$	-	-	-	++++	25
ADDC A,@IX +off	4	2	$(A) \leftarrow (A) + ((IX) + off) + C$	-	-	-	++++	26
ADDC A,@EP	3	1	$(A) \leftarrow (A) + ((EP)) + C$	-	-	-	++++	27
ADDCW A	3	1	$(A) \leftarrow (A) + (T) + C$	-	-	dH	++++	23
ADDC A	2	1	$(AL) \leftarrow (AL) + (TL) + C$	-	-	-	++++	22
SUBC A,Ri	3	1	$(A) \leftarrow (A) - (Ri) - C$	-	-	-	++++	38 to 3F
SUBC A,#d8	2	2	$(A) \leftarrow (A) - d8 - C$	-	-	-	++++	34
SUBC A,dir	3	2	$(A) \leftarrow (A) - (dir) - C$	-	-	-	++++	35
SUBC A,@IX +off	4	2	$(A) \leftarrow (A) - ((IX) + off) - C$	-	-	-	++++	36
SUBC A,@EP	3	1	$(A) \leftarrow (A) - ((EP)) - C$	-	-	-	++++	37
SUBCW A	3	1	$(A) \leftarrow (T) - (A) - C$	-	-	dH	++++	33
SUBC A	2	1	$(AL) \leftarrow (TL) - (AL) - C$	-	-	-	++++	32
INC Ri	4	1	$(Ri) \leftarrow (Ri) + 1$	-	-	-	+++-	C8 to CF
INCW EP	3	1	$(EP) \leftarrow (EP) + 1$	-	-	-	----	C3
INCW IX	3	1	$(IX) \leftarrow (IX) + 1$	-	-	-	----	C2
INCW A	3	1	$(A) \leftarrow (A) + 1$	-	-	dH	++--	C0
DEC Ri	4	1	$(Ri) \leftarrow (Ri) - 1$	-	-	-	+++-	D8 to DF
DECW EP	3	1	$(EP) \leftarrow (EP) - 1$	-	-	-	----	D3
DECW IX	3	1	$(IX) \leftarrow (IX) - 1$	-	-	-	----	D2
DECW A	3	1	$(A) \leftarrow (A) - 1$	-	-	dH	++--	D0
MULU A	19	1	$(A) \leftarrow (AL) \times (TL)$	-	-	dH	----	01
DIVU A	21	1	$(A) \leftarrow (T) / (AL), MOD \rightarrow (T)$	dL	00	00	----	11
ANDW A	3	1	$(A) \leftarrow (A) \wedge (T)$	-	-	dH	++R-	63
ORW A	3	1	$(A) \leftarrow (A) \vee (T)$	-	-	dH	++R-	73
XORW A	3	1	$(A) \leftarrow (A) \nabla (T)$	-	-	dH	++R-	53
CMP A	2	1	$(TL) - (AL)$	-	-	-	++++	12
CMPW A	3	1	$(T) - (A)$	-	-	-	++++	13
RORC A	2	1	$\rightarrow C \rightarrow A$	-	-	-	++-+	03
ROLC A	2	1	$C \leftarrow A \leftarrow$	-	-	-	++-+	02
CMP A,#d8	2	2	$(A) - d8$	-	-	-	++++	14
CMP A,dir	3	2	$(A) - (dir)$	-	-	-	++++	15
CMP A,@EP	3	1	$(A) - ((EP))$	-	-	-	++++	17
CMP A,@IX +off	4	2	$(A) - ((IX) + off)$	-	-	-	++++	16
CMP A,Ri	3	1	$(A) - (Ri)$	-	-	-	++++	18 to 1F
DAA	2	1	Decimal adjust for addition	-	-	-	++++	84
DAS	2	1	Decimal adjust for subtraction	-	-	-	++++	94
XOR A	2	1	$(A) \leftarrow (AL) \nabla (TL)$	-	-	-	++R-	52
XOR A,#d8	2	2	$(A) \leftarrow (AL) \nabla d8$	-	-	-	++R-	54
XOR A,dir	3	2	$(A) \leftarrow (AL) \nabla (dir)$	-	-	-	++R-	55
XOR A,@EP	3	1	$(A) \leftarrow (AL) \nabla ((EP))$	-	-	-	++R-	57
XOR A,@IX +off	4	2	$(A) \leftarrow (AL) \nabla ((IX) + off)$	-	-	-	++R-	56
XOR A,Ri	3	1	$(A) \leftarrow (AL) \nabla (Ri)$	-	-	-	++R-	58 to 5F
AND A	2	1	$(A) \leftarrow (AL) \wedge (TL)$	-	-	-	++R-	62
AND A,#d8	2	2	$(A) \leftarrow (AL) \wedge d8$	-	-	-	++R-	64
AND A,dir	3	2	$(A) \leftarrow (AL) \wedge (dir)$	-	-	-	++R-	65

(Continued)

(Continued)

Mnemonic	~	#	Operation	TL	TH	AH	NZVC	OP code
AND A,@EP	3	1	$(A) \leftarrow (AL) \wedge (EP)$	-	-	-	++R-	67
AND A,@IX +off	4	2	$(A) \leftarrow (AL) \wedge ((IX) + \text{off})$	-	-	-	++R-	66
AND A,Ri	3	1	$(A) \leftarrow (AL) \wedge (Ri)$	-	-	-	++R-	68 to 6F
OR A	2	1	$(A) \leftarrow (AL) \vee (TL)$	-	-	-	++R-	72
OR A,#d8	2	2	$(A) \leftarrow (AL) \vee d8$	-	-	-	++R-	74
OR A,dir	3	2	$(A) \leftarrow (AL) \vee (\text{dir})$	-	-	-	++R-	75
OR A,@EP	3	1	$(A) \leftarrow (AL) \vee (EP)$	-	-	-	++R-	77
OR A,@IX +off	4	2	$(A) \leftarrow (AL) \vee ((IX) + \text{off})$	-	-	-	++R-	76
OR A,Ri	3	1	$(A) \leftarrow (AL) \vee (Ri)$	-	-	-	++R-	78 to 7F
CMP dir,#d8	5	3	$(\text{dir}) - d8$	-	-	-	++++	95
CMP @EP,#d8	4	2	$(EP) - d8$	-	-	-	++++	97
CMP @IX +off,#d8	5	3	$((IX) + \text{off}) - d8$	-	-	-	++++	96
CMP Ri,#d8	4	2	$(Ri) - d8$	-	-	-	++++	98 to 9F
INCW SP	3	1	$(SP) \leftarrow (SP) + 1$	-	-	-	----	C1
DECW SP	3	1	$(SP) \leftarrow (SP) - 1$	-	-	-	----	D1

**Table 4 Branch Instructions (17 instructions)**

Mnemonic	~	#	Operation	TL	TH	AH	NZVC	OP code
BZ/BEQ rel	3	2	If $Z = 1$ then $PC \leftarrow PC + \text{rel}$	-	-	-	----	FD
BNZ/BNE rel	3	2	If $Z = 0$ then $PC \leftarrow PC + \text{rel}$	-	-	-	----	FC
BC/BLO rel	3	2	If $C = 1$ then $PC \leftarrow PC + \text{rel}$	-	-	-	----	F9
BNC/BHS rel	3	2	If $C = 0$ then $PC \leftarrow PC + \text{rel}$	-	-	-	----	F8
BN rel	3	2	If $N = 1$ then $PC \leftarrow PC + \text{rel}$	-	-	-	----	FB
BP rel	3	2	If $N = 0$ then $PC \leftarrow PC + \text{rel}$	-	-	-	----	FA
BLT rel	3	2	If $V \vee N = 1$ then $PC \leftarrow PC + \text{rel}$	-	-	-	----	FF
BGE rel	3	2	If $V \vee N = 0$ then $PC \leftarrow PC + \text{rel}$	-	-	-	----	FE
BBC dir: b,rel	5	3	If $(\text{dir: } b) = 0$ then $PC \leftarrow PC + \text{rel}$	-	-	-	-+---	B0 to B7
BBS dir: b,rel	5	3	If $(\text{dir: } b) = 1$ then $PC \leftarrow PC + \text{rel}$	-	-	-	-+---	B8 to BF
JMP @A	2	1	$(PC) \leftarrow (A)$	-	-	-	----	E0
JMP ext	3	3	$(PC) \leftarrow \text{ext}$	-	-	-	----	21
CALLV #vct	6	1	Vector call	-	-	-	----	E8 to EF
CALL ext	6	3	Subroutine call	-	-	-	----	31
XCHW A,PC	3	1	$(PC) \leftarrow (A), (A) \leftarrow (PC) + 1$	-	-	dH	----	F4
RET	4	1	Return from subroutine	-	-	-	----	20
RETI	6	1	Return from interrupt	-	-	-	Restore	30

**Table 5 Other Instructions (9 instructions)**

Mnemonic	~	#	Operation	TL	TH	AH	NZVC	OP code
PUSHW A	4	1		-	-	-	----	40
POPW A	4	1		-	-	dH	----	50
PUSHW IX	4	1		-	-	-	----	41
POPW IX	4	1		-	-	-	----	51
NOP	1	1		-	-	-	----	00
CLRC	1	1		-	-	-	----R	81
SETC	1	1		-	-	-	----S	91
CLRI	1	1		-	-	-	----	80
SETI	1	1		-	-	-	----	90

# MB89130/130A Series

## INSTRUCTION MAP

L	H	0	1	2	3	4	5	6	7	8	9	A	B	C	D	E	F
0	NOP	SWAP	RET	RETI	PUSHW A	PUSHW IX	POPW A	MOV A,ext	MOVW A,PS	CLR	SETI	CLRB dir: 0	BBC dir: 0,rel	INCW A	DECW A	JMP @A	MOVW A,PC
1	MULU A	DIVU A	JMP addr16	CALL addr16	PUSHW IX	PUSHW IX	POPW PS,A	MOV ext,A	MOVW PS,A	CLRC	SETC	CLRB dir: 1	BBC dir: 1,rel	INCW SP	DECW SP	MOVW SPA	MOVW A,SP
2	ROL	CMP A	ADDC A	SUBC A	XCH A,T	XCH A,T	XOR A	AND A	OR A	MOV @A,T	MOV A,@A	CLRB dir: 2	BBC dir: 2,rel	INCW IX	DECW IX	MOVW IX,A	MOVW A,IX
3	ROR	CMPW A	ADDCW A	SUBCW A	XCHW A,T	XCHW A,T	XORW A	ANDW A	ORW A	MOVW @A,T	MOVW A,@A	CLRB dir: 3	BBC dir: 3,rel	INCW EP	DECW EP	MOVW EPA	MOVW A,EP
4	MOV A,#d8	CMP A,#d8	ADDC A,#d8	SUBC A,#d8	XOR A,#d8	XOR A,#d8	XOR A,#d8	AND A,#d8	OR A,#d8	DAA	DAS	CLRB dir: 4	BBC dir: 4,rel	MOVW A,ext	MOVW ext,A	MOVW A,#d16	XCHW A,PC
5	MOV A,dir	CMP A,dir	ADDC A,dir	SUBC A,dir	XOR A,dir	XOR A,dir	XOR A,dir	AND A,dir	OR A,dir	MOV dir,#d8	CMP dir,#d8	CLRB dir: 5	BBC dir: 5,rel	MOVW A,dir	MOVW dir,A	MOVW SP#d16	XCHW A,SP
6	MOV A,@IX+d	CMP A,@IX+d	ADDC A,@IX+d	SUBC A,@IX+d	XOR A,@IX+d	XOR A,@IX+d	XOR A,@IX+d	AND A,@IX+d	OR A,@IX+d	MOV @IX+d,#d8	CMP @IX+d,#d8	CLRB dir: 6	BBC dir: 6,rel	MOVW A,@IX+d	MOVW @IX+d,A	MOVW IX#d16	XCHW A,IX
7	MOV A,@EP	CMP A,@EP	ADDC A,@EP	SUBC A,@EP	XOR A,@EP	XOR A,@EP	XOR A,@EP	AND A,@EP	OR A,@EP	MOV @EP#d8	CMP @EP#d8	CLRB dir: 7	BBC dir: 7,rel	MOVW A,@EP	MOVW @EP,A	MOVW EP#d16	XCHW A,EP
8	MOV A,R0	CMP A,R0	ADDC A,R0	SUBC A,R0	XOR R0,A	MOV R0,A	XOR A,R0	AND A,R0	OR A,R0	MOV R0,#d8	CMP R0,#d8	SETB dir: 0	BBS dir: 0,rel	INC R0	DEC R0	CALLV #0	BNC rel
9	MOV A,R1	CMP A,R1	ADDC A,R1	SUBC A,R1	MOV R1,A	MOV R1,A	XOR A,R1	AND A,R1	OR A,R1	MOV R1,#d8	CMP R1,#d8	SETB dir: 1	BBS dir: 1,rel	INC R1	DEC R1	CALLV #1	BC rel
A	MOV A,R2	CMP A,R2	ADDC A,R2	SUBC A,R2	MOV R2,A	MOV R2,A	XOR A,R2	AND A,R2	OR A,R2	MOV R2,#d8	CMP R2,#d8	SETB dir: 2	BBS dir: 2,rel	INC R2	DEC R2	CALLV #2	BP rel
B	MOV A,R3	CMP A,R3	ADDC A,R3	SUBC A,R3	MOV R3,A	MOV R3,A	XOR A,R3	AND A,R3	OR A,R3	MOV R3,#d8	CMP R3,#d8	SETB dir: 3	BBS dir: 3,rel	INC R3	DEC R3	CALLV #3	BN rel
C	MOV A,R4	CMP A,R4	ADDC A,R4	SUBC A,R4	MOV R4,A	MOV R4,A	XOR A,R4	AND A,R4	OR A,R4	MOV R4,#d8	CMP R4,#d8	SETB dir: 4	BBS dir: 4,rel	INC R4	DEC R4	CALLV #4	BNZ rel
D	MOV A,R5	CMP A,R5	ADDC A,R5	SUBC A,R5	MOV R5,A	MOV R5,A	XOR A,R5	AND A,R5	OR A,R5	MOV R5,#d8	CMP R5,#d8	SETB dir: 5	BBS dir: 5,rel	INC R5	DEC R5	CALLV #5	BZ rel
E	MOV A,R6	CMP A,R6	ADDC A,R6	SUBC A,R6	MOV R6,A	MOV R6,A	XOR A,R6	AND A,R6	OR A,R6	MOV R6,#d8	CMP R6,#d8	SETB dir: 6	BBS dir: 6,rel	INC R6	DEC R6	CALLV #6	BGE rel
F	MOV A,R7	CMP A,R7	ADDC A,R7	SUBC A,R7	MOV R7,A	MOV R7,A	XOR A,R7	AND A,R7	OR A,R7	MOV R7,#d8	CMP R7,#d8	SETB dir: 7	BBS dir: 7,rel	INC R7	DEC R7	CALLV #7	BLT rel

## ■ MASK OPTIONS

No.	Part number	MB89131	MB89133A MB89135A	MB89P131 MB89P133A
	Specifying procedure	Specify when ordering masking	Specify when ordering masking	Specify when ordering masking
1	Pull-up resistors { <ul style="list-style-type: none"> <li>•P00 to P07, P10 to P17,</li> <li>•P30 to P37, P40 to P43</li> </ul>	Selectable by pin (P40 to P43 must be fixed to no pull-up resistor option when an A/D converter is used.)	Selectable by pin (P40 to P43 must be fixed to no pull-up resistor option when an A/D converter is used.)	Selectable by pin (P40 to P43 must be fixed to no pull-up resistor option when an A/D converter is used.)
2	Power-on reset { <ul style="list-style-type: none"> <li>•Power-on reset provided</li> <li>•No power-on reset</li> </ul>	Selectable	Selectable	Selectable
3	Selection of oscillation stabilization time •The oscillation stabilization time initial value is selectable from 4 types given below. 0 : Oscillation stabilization $2^2/F_{CH}$ 1 : Oscillation stabilization $2^{12}/F_{CH}$ 2 : Oscillation stabilization $2^{16}/F_{CH}$ 3 : Oscillation stabilization $2^{18}/F_{CH}$	Selectable	Selectable	Selectable
4	Reset pin output { <ul style="list-style-type: none"> <li>•Reset output enabled</li> <li>•Reset output disabled</li> </ul>	Selectable	Selectable	Selectable
5	Clock mode selection { <ul style="list-style-type: none"> <li>•Single-clock mode</li> <li>•Dual-clock mode</li> </ul>	Selectable	Selectable	Selectable
6	Selection of oscillation circuit type { <ul style="list-style-type: none"> <li>•Crystal or ceramic oscillation type</li> <li>•External clock input type</li> </ul>	Selectable	Selectable	Not required <sup>*1</sup>
7	Peripheral control clock output function <sup>*2</sup> { <ul style="list-style-type: none"> <li>•Not used</li> <li>•Used</li> </ul>	Selectable	Not required <sup>*3</sup>	Not required <sup>*3</sup>

\*1 : Both external clock and oscillation resonator can be used on the OTPROM product.

\*2 : "Used" must be selected when P33 (39 pin) is used as SCO for the peripheral control clock output.

\*3 : The peripheral control clock output function can be used only by software.

# MB89130/130A Series

No.	Part number	MB89P135A	MB89PV130A
	Specifying procedure	Set with EPROM programmer	Setting not possible
1	Pull-up resistors •P00 to P07, P10 to P17, •P30 to P37, P40 to P43	Selectable by pin (P40 to P43 must be fixed to no pull-up resistor option.)	All pins fixed to no pull-up resistor option
2	Power-on reset •Power-on reset provided •No power-on reset	Selectable	Power-on reset provided
3	Selection of oscillation stabilization wait time •The oscillation stabilization time initial value is selectable from 4 types given below. 0 : Oscillation stabilization $2^2/F_{CH}$ 1 : Oscillation stabilization $2^{12}/F_{CH}$ 2 : Oscillation stabilization $2^{16}/F_{CH}$ 3 : Oscillation stabilization $2^{18}/F_{CH}$	Selectable	Oscillation stabilization $2^{18}/F_{CH}$
4	Reset pin output •Reset output enabled •Reset output disabled	Selectable	Reset output enabled
5	Selection of clock mode selection •Single-clock mode •Dual-clock mode	Selectable	Dual-clock mode
6	Selection of oscillation circuit type •Crystal or ceramic oscillation type •External clock input type	Not required <sup>*1</sup>	Not required <sup>*1</sup>
7	Peripheral control clock output function <sup>*2</sup> •Not used •Used	Not required <sup>*3</sup>	Not required <sup>*3</sup>

\*1 : Both external clock and oscillation resonator can be used.

\*2 : "Used" must be selected when P33 (39 pin) is used as SCO for the peripheral control clock output.

\*3 : The peripheral control clock output function can be used only by software.

# MB89130/130A Series

## ■ MB89P131/P133A STANDARD OPTIONS

No.	Product option	MB89P131-101	MB89P133A-201
1	Pull-up resistor	Not provided for any port	Not provided for any port
2	Power-on reset	Provided	Provided
3	Selection of oscillation stabilization time	2 : Oscillation stabilization $2^{16}/F_{CH}$	2 : Oscillation stabilization $2^{16}/F_{CH}$
4	Reset pin output	Enabled	Disabled
5	Selection of clock mode	Dual-clock mode	Dual-clock mode

## ■ ORDERING INFORMATION

Part number	Package	Remarks
MB89131PFM MB89133APFM MB89135APFM MB89P131PFM-101 MB89P133APFM-201 MB89P135APFM	48-pin Plastic QFP (FPT-48P-M13)	
MB89133AP MB89P133AP-201	48-pin Plastic SH-DIP (DIP-48P-M01)	
MB89PV130ACF-ES	48-pin Ceramic MQFP (MQP-48C-P01)	

# MB89130/130A Series

## PACKAGE DIMENSION

48-pin Plastic QFP  
(FPT-48P-M13)

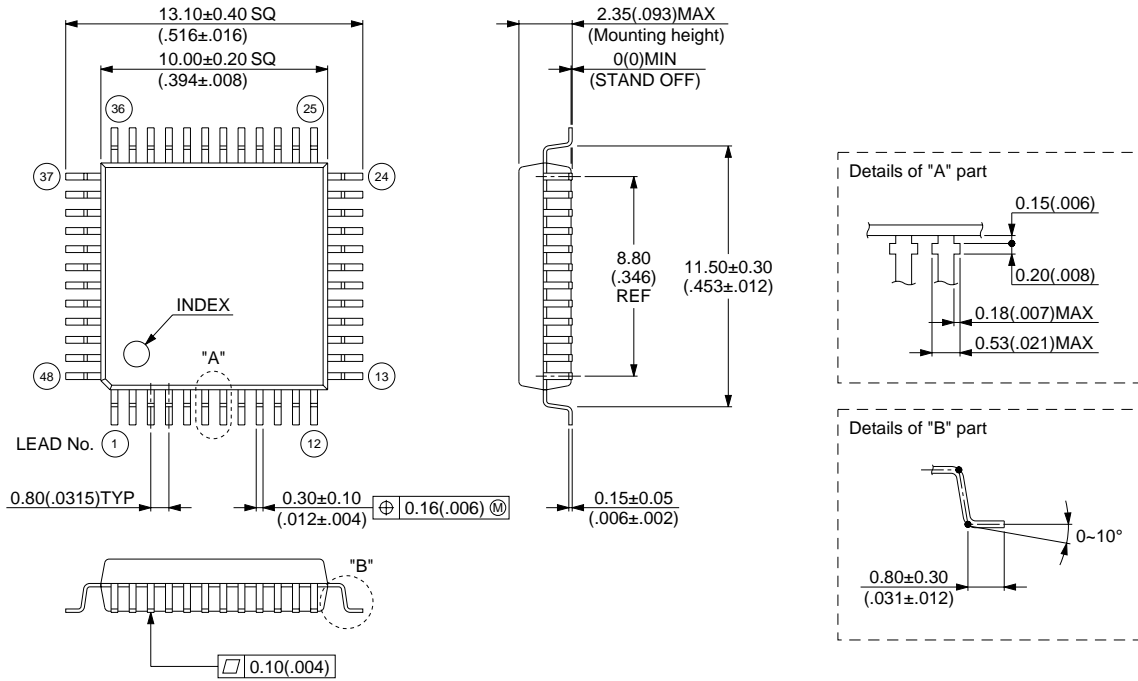

© 1994 FUJITSU LIMITED F48023S-1C-1

Dimensions in mm (inches)

(Continued)



# MB89130/130A Series

48-pin Plastic SH-DIP  
(DIP-48P-M01)

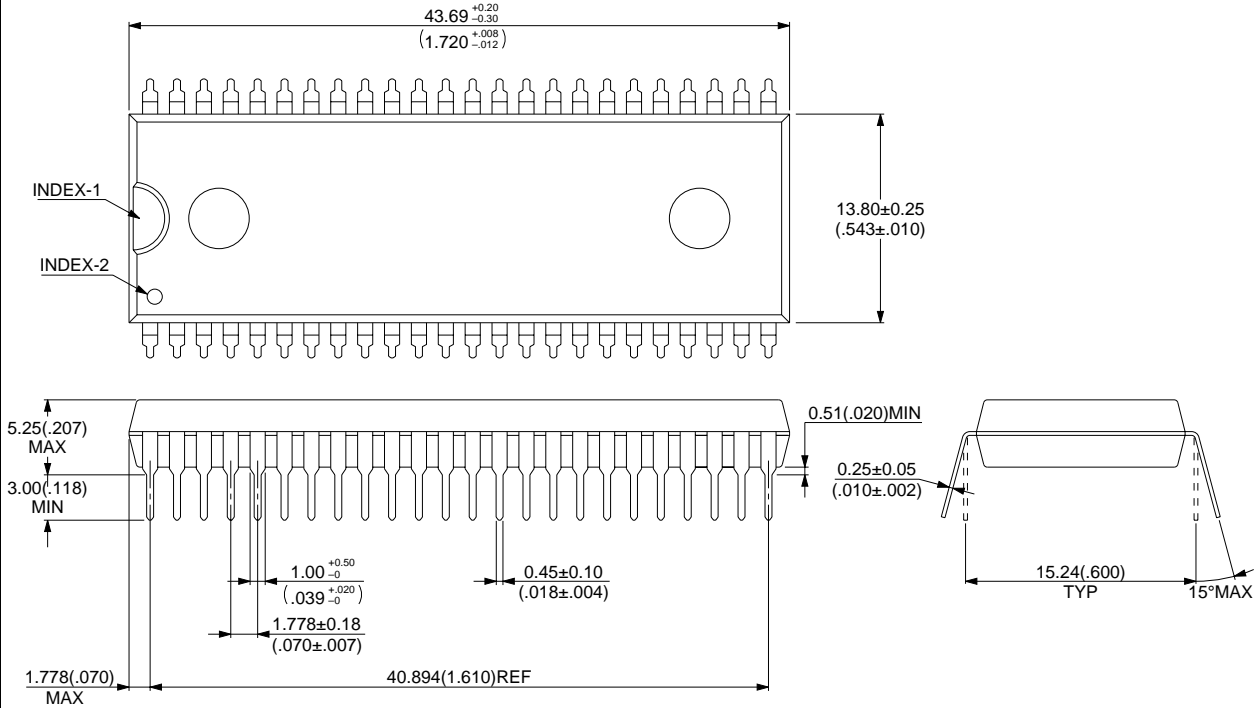

© 1994 FUJITSU LIMITED D48002S-3C-3

Dimensions in mm (inches)

(Continued)

# MB89130/130A Series

(Continued)

48-pin Ceramic MQFP  
(MQP-48C-P01)

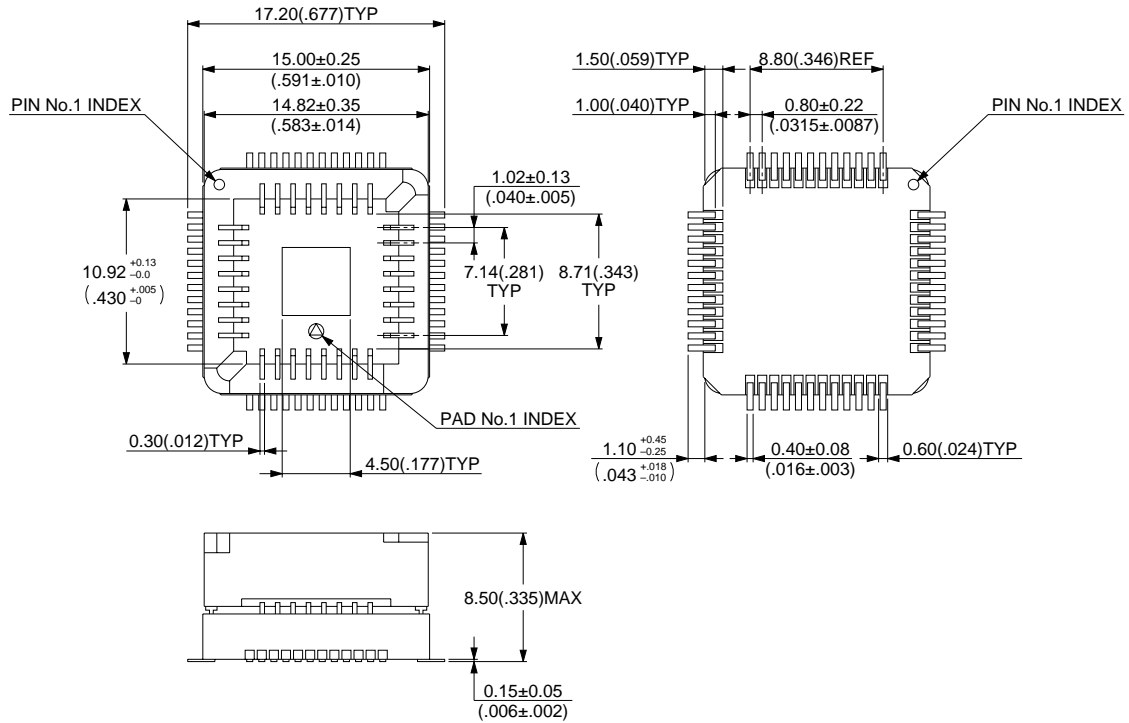

© 1994 FUJITSU LIMITED M48001SC-4-2

Dimensions in mm (inches)

# MB89130/130A Series

## FUJITSU LIMITED

*For further information please contact:*

### Japan

FUJITSU LIMITED  
Corporate Global Business Support Division  
Electronic Devices  
Shinjuku Dai-Ichi Seimei Bldg. 7-1,  
Nishishinjuku 2-chome, Shinjuku-ku,  
Tokyo 163-0721, Japan  
Tel: +81-3-5322-3347  
Fax: +81-3-5322-3386

<http://www.fujitsu.co.jp/>

### North and South America

FUJITSU MICROELECTRONICS, INC.  
3545 North First Street,  
San Jose, CA 95134-1804, U.S.A.  
Tel: +1-408-922-9000  
Fax: +1-408-922-9179

Customer Response Center  
*Mon. - Fri.: 7 am - 5 pm (PST)*  
Tel: +1-800-866-8608  
Fax: +1-408-922-9179

<http://www.fujitsumicro.com/>

### Europe

FUJITSU MICROELECTRONICS EUROPE GmbH  
Am Siebenstein 6-10,  
D-63303 Dreieich-Buchsschlag,  
Germany  
Tel: +49-6103-690-0  
Fax: +49-6103-690-122

<http://www.fujitsu-fme.com/>

### Asia Pacific

FUJITSU MICROELECTRONICS ASIA PTE. LTD.  
#05-08, 151 Lorong Chuan,  
New Tech Park,  
Singapore 556741  
Tel: +65-281-0770  
Fax: +65-281-0220

<http://www.fmap.com.sg/>

### Korea

FUJITSU MICROELECTRONICS KOREA LTD.  
1702 KOSMO TOWER, 1002 Daechi-Dong,  
Kangnam-Gu, Seoul 135-280  
Korea  
Tel: +82-2-3484-7100  
Fax: +82-2-3484-7111

F0008

© FUJITSU LIMITED Printed in Japan

All Rights Reserved.

The contents of this document are subject to change without notice. Customers are advised to consult with FUJITSU sales representatives before ordering.

The information and circuit diagrams in this document are presented as examples of semiconductor device applications, and are not intended to be incorporated in devices for actual use. Also, FUJITSU is unable to assume responsibility for infringement of any patent rights or other rights of third parties arising from the use of this information or circuit diagrams.

The contents of this document may not be reproduced or copied without the permission of FUJITSU LIMITED.

FUJITSU semiconductor devices are intended for use in standard applications (computers, office automation and other office equipments, industrial, communications, and measurement equipments, personal or household devices, etc.).

#### CAUTION:

Customers considering the use of our products in special applications where failure or abnormal operation may directly affect human lives or cause physical injury or property damage, or where extremely high levels of reliability are demanded (such as aerospace systems, atomic energy controls, sea floor repeaters, vehicle operating controls, medical devices for life support, etc.) are requested to consult with FUJITSU sales representatives before such use. The company will not be responsible for damages arising from such use without prior approval.

Any semiconductor devices have inherently a certain rate of failure. You must protect against injury, damage or loss from such failures by incorporating safety design measures into your facility and equipment such as redundancy, fire protection, and prevention of over-current levels and other abnormal operating conditions.

If any products described in this document represent goods or technologies subject to certain restrictions on export under the Foreign Exchange and Foreign Trade Control Law of Japan, the prior authorization by Japanese government should be required for export of those products from Japan.