

FEATURES

- 375ps propagation delay
- 1.6V output swings
- Internal 75KΩ input pull-down resistors
- Available in 8-pin SOIC package

DESCRIPTION

The SY10EL89 is a differential fanout gate specifically designed to drive coaxial cables. The device is especially useful in Digital Video Broadcast applications. For this application, since the system is polarity-free, each output of the device can be used as an independent driver. The driver boasts a voltage gain of approximately 40 and produces output swings twice as large as a standard ECL output. When driving a coaxial cable, proper termination is required at both ends of the line to minimize signal loss. The 1.6V output swings allow for termination at both ends of the cable while maintaining the required 800mV swing at the receiving end of the cable. Because of the larger output swings, the device cannot be terminated into the standard $-2.0V$. All of the DC parameters are tested with a 50Ω to $-3.0V$ load. The driver accepts a standard differential ECL input and can run off the Digital Video Broadcast standard $-5.0V$ supply.

PIN CONFIGURATION/BLOCK DIAGRAM

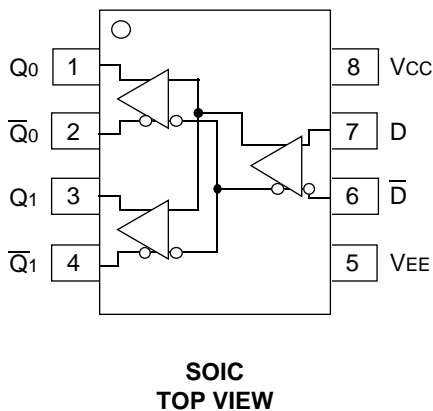

PIN NAMES

Pin	Function
D	Data Inputs
Q0, Q1	Data Outputs

DC ELECTRICAL CHARACTERISTICS

$V_{EE} = V_{EE} (\text{Min.})$ to $V_{EE} (\text{Max.})$; $V_{CC} = \text{GND}$

Symbol	Parameter	$T_A = -40^\circ\text{C}$			$T_A = 0^\circ\text{C}$			$T_A = +25^\circ\text{C}$			$T_A = +85^\circ\text{C}$			Unit
		Min.	Typ.	Max.	Min.	Typ.	Max.	Min.	Typ.	Max.	Min.	Typ.	Max.	
I_{EE}	Power Supply Current	18	23	28	18	23	28	18	23	28	18	23	28	mA
V_{OH}	Output HIGH Voltage ⁽¹⁾	-1.23	-1.10	-0.98	-1.17	-1.05	-0.93	-1.13	-1.02	-0.90	-1.06	-0.96	-0.81	V
V_{OL}	Output LOW Voltage ⁽¹⁾	-2.84	-2.72	-2.58	-2.84	-2.70	-2.56	-2.84	-2.70	-2.56	-2.84	-2.67	-2.51	V
V_{EE}	Power Supply Voltage	-4.75	—	-5.5	-4.75	—	-5.5	-4.75	—	-5.5	-4.75	—	-5.5	V
I_{IH}	Input HIGH Current	—	—	150	—	—	150	—	—	150	—	—	150	μA

NOTE:

- V_{OH} and V_{OL} specified for 50Ω to -3.0V load.

AC ELECTRICAL CHARACTERISTICS

$V_{EE} = V_{EE} (\text{Min.})$ to $V_{EE} (\text{Max.})$; $V_{CC} = \text{GND}$

Symbol	Parameter	$T_A = -40^\circ\text{C}$			$T_A = 0^\circ\text{C}$			$T_A = +25^\circ\text{C}$			$T_A = +85^\circ\text{C}$			Unit
		Min.	Typ.	Max.	Min.	Typ.	Max.	Min.	Typ.	Max.	Min.	Typ.	Max.	
t_{PLH} t_{PHL}	Propagation Delay to Output D	200	340	480	250	340	430	260	350	440	310	400	490	ps
t_{skew}	Within-Device Skew	—	5	20	—	5	20	—	5	20	—	5	20	ps
V_{PP}	Minimum Input Swing ⁽¹⁾	150	—	—	150	—	—	150	—	—	150	—	—	mV
V_{CMR}	Common Mode Range ⁽²⁾	(2)	—	-0.4	(2)	—	-0.4	(2)	—	-0.4	(2)	—	-0.4	V
t_r t_f	Output Rise/Fall Times Q (20% to 80%)	205	330	455	205	330	455	205	330	455	205	330	455	ps

NOTES:

- Minimum input swing for which AC parameters are guaranteed. The device has a DC gain of ≈ 40 .
- The CMR range is referenced to the most positive side of the differential input signal. Normal operation is obtained if the HIGH level falls within the specified range and the peak-to-peak voltage lies between $V_{PP \text{ min.}}$ and 1V . The lower end of the CMR range is dependent on V_{EE} and is equal to $V_{EE} + 3.0\text{V}$.

DC BLOCKING CAPACITORS

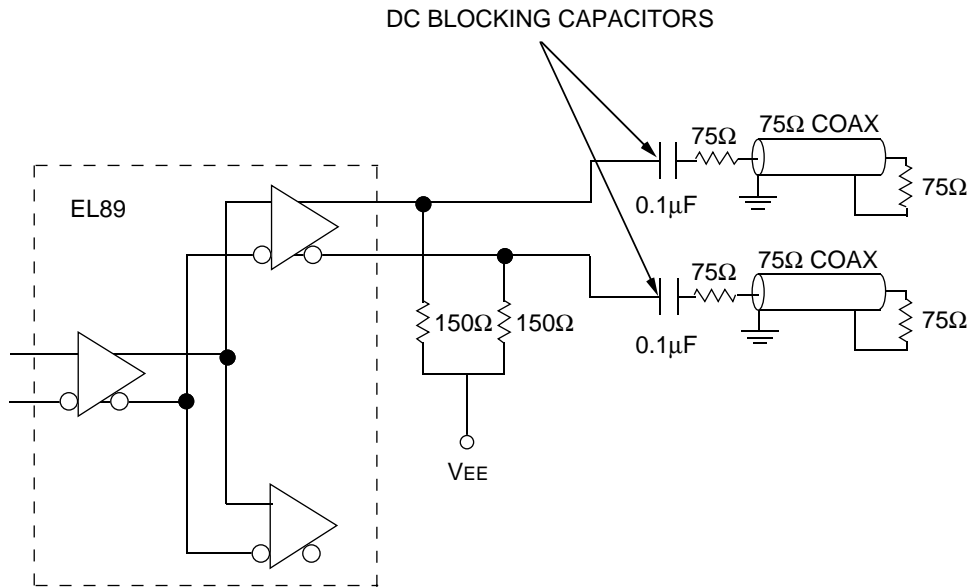
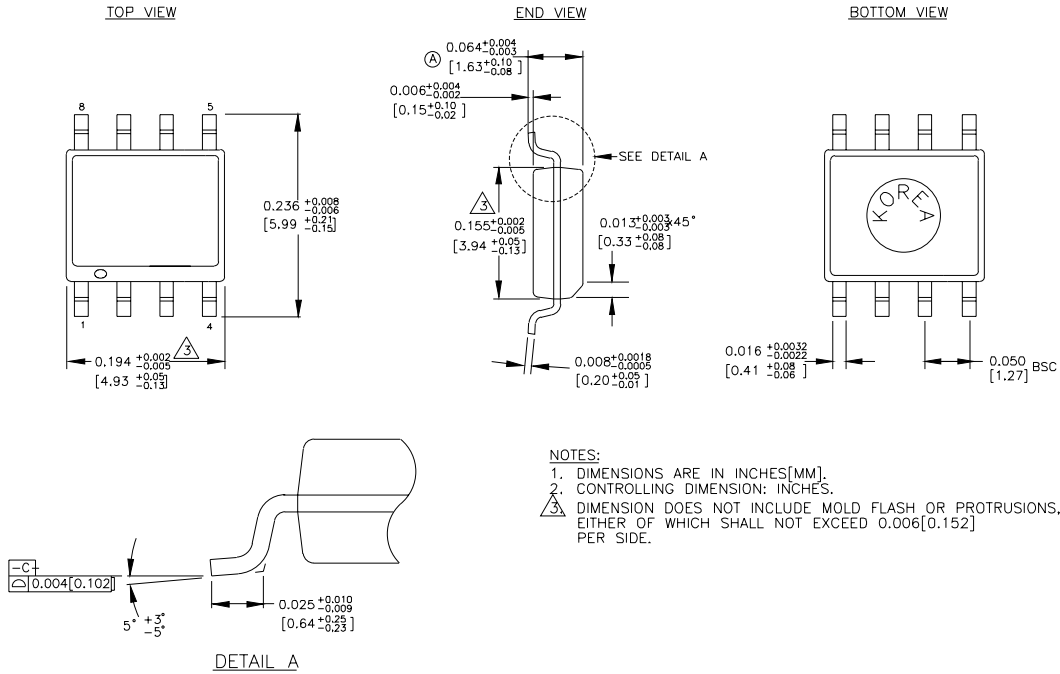

Figure 1. Termination Configuration

PRODUCT ORDERING CODE

Ordering Code	Package Type	Operating Range
SY10EL89ZC	Z8-1	Commercial
SY10EL89ZCTR	Z8-1	Commercial

8 LEAD SOIC .150" WIDE (Z8-1)



Rev. 03

MICREL-SYNERGY 3250 SCOTT BOULEVARD SANTA CLARA CA 95054 USA

TEL + 1 (408) 980-9191 FAX + 1 (408) 914-7878 WEB <http://www.micrel.com>

This information is believed to be accurate and reliable, however no responsibility is assumed by Micrel for its use nor for any infringement of patents or other rights of third parties resulting from its use. No license is granted by implication or otherwise under any patent or patent right of Micrel Inc.

© 2000 Micrel Incorporated