

16-BIT MCU WITH 128K BYTE FLASH MEMORY

PRELIMINARY DATASHEET

- High Performance 16-bit CPU with 4-Stage Pipeline
- 100 ns Instruction Cycle Time at 20MHz CPU Clock
- 500 ns Multiplication (16×16 bit), $1 \mu\text{s}$ Division (32 / 16 bit)
- Enhanced Boolean Bit Manipulation Facilities
- Additional Instructions to Support HLL and Operating Systems
- Register-Based Design with Multiple Variable Register Banks
- Single-Cycle Context Switching Support
- Clock Generation via on-chip PLL or via direct clock input
- Up to 16 MBytes Linear Address Space for Code and Data
- 2K Bytes On-Chip Internal RAM (IRAM)
- 2K Bytes On-Chip Extension RAM (XRAM)
- **128K Bytes On-Chip FLASH memory**
- FLASH Memory organized into 4 banks independently erasable
- Programmable External Bus Characteristics for Different Address Ranges
- 8-Bit or 16-Bit External Data Bus
- Multiplexed or Demultiplexed External Address/Data Buses
- Five Programmable Chip-Select Signals
- Hold- and Hold-Acknowledge Bus Arbitration Support
- 1024 Bytes On-Chip Special Function Register Area
- Idle and Power Down Modes
- 8-Channel Interrupt-Driven Single-Cycle Data Transfer Facilities via Peripheral Event Controller (PEC)
- 16-Priority-Level Interrupt System with 56 Sources, Sample-Rate down to 50 ns
- 16-Channel 10-bit A/D Converter with $9.7 \mu\text{s}$ Conversion Time
- Two 16-Channel Capture/Compare Units

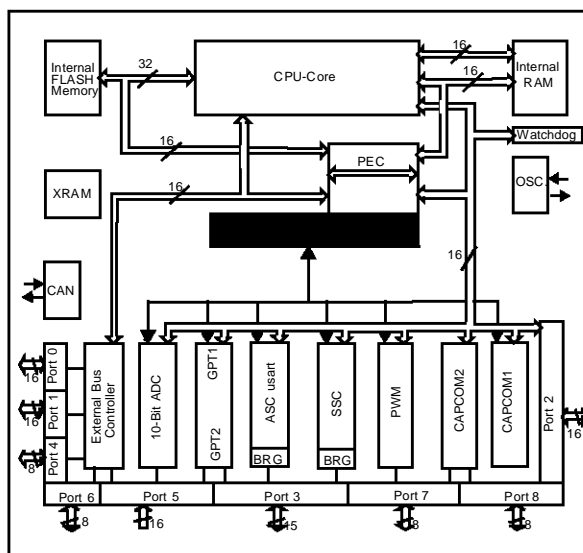

- 4-Channel PWM Unit
- Two Multi-Functional General Purpose Timer Units with 5 Timers
- Two Serial Channels (Synchronous/Asynchronous and High-Speed-Synchronous)
- On-Chip CAN 2.0B Interface with 15 Message Objects (Full-CAN/Basic-CAN)
- Programmable Watchdog Timer
- Up to 111 General Purpose I/O Lines, partly with Selectable Input Thresholds and Hysteresis
- Supported by development tools: C-Compilers, Macro-Assembler Packages, Emulators, Evaluation Boards, HLL-Debuggers, Simulators, Logic Analyzer Disassemblers, Programming Boards
- On-Chip Bootstrap Loader
- 144-Pin PQFP Package

Table of Contents

1	INTRODUCTION	4
2	PIN DATA	5
3	FUNCTIONAL DESCRIPTION	12
4	MEMORY ORGANIZATION	13
5	EXTERNAL BUS CONTROLLER	13
6	FLASH MEMORY	14
6.1	Flash Memory Programming And Erasure	14
6.2	Flash Control Register (FCR)	15
6.3	Flash Memory Security	16
7	CENTRAL PROCESSING UNIT (CPU)	19
8	INTERRUPT SYSTEM	20
9	CAPTURE/COMPARE (CAPCOM) UNITS	24
10	GENERAL PURPOSE TIMER (GPT) UNIT	26
11	PWM MODULE	28
12	WATCHDOG TIMER	29
13	A/D CONVERTER	29
14	SERIAL CHANNELS	30
15	CAN-MODULE	30
16	PARALLEL PORTS	31
17	INSTRUCTION SET SUMMARY	32
18	BOOTSTRAP LOADER	33
19	SPECIAL FUNCTION REGISTER OVERVIEW	34
20	ELECTRICAL CHARACTERISTICS	41
20.1	Absolute Maximum Ratings	41
20.2	Parameter Interpretation	41
20.3	DC Characteristics	42
20.4	A/D Converter Characteristics	45
20.5	AC Characteristics	47
20.5.1	Test Waveforms	47
20.5.2	Definition of Internal Timing	48
20.5.3	Direct Drive	48
20.5.4	Phase Locked Loop	49
20.5.5	External Clock Drive XTAL1	50
20.5.6	Memory Cycle Variables	50
20.5.7	Multiplexed Bus	51

20.5.8	Demultiplexed Bus	57
20.5.9	CLKOUT and READY	63
20.5.10	External Bus Arbitration	65
21	PACKAGE MECHANICAL DATA	68
22	ORDERING INFORMATION	68

1 INTRODUCTION

The ST10F167 is a flash derivative of the SGS-THOMSON ST10 family of full featured single-chip CMOS microcontrollers. It combines high CPU performance with high peripheral functional-

ty and enhanced IO-capabilities. It also provides on-chip high-speed RAM and clock generation via PLL.

Figure 1.1 Logic Symbol

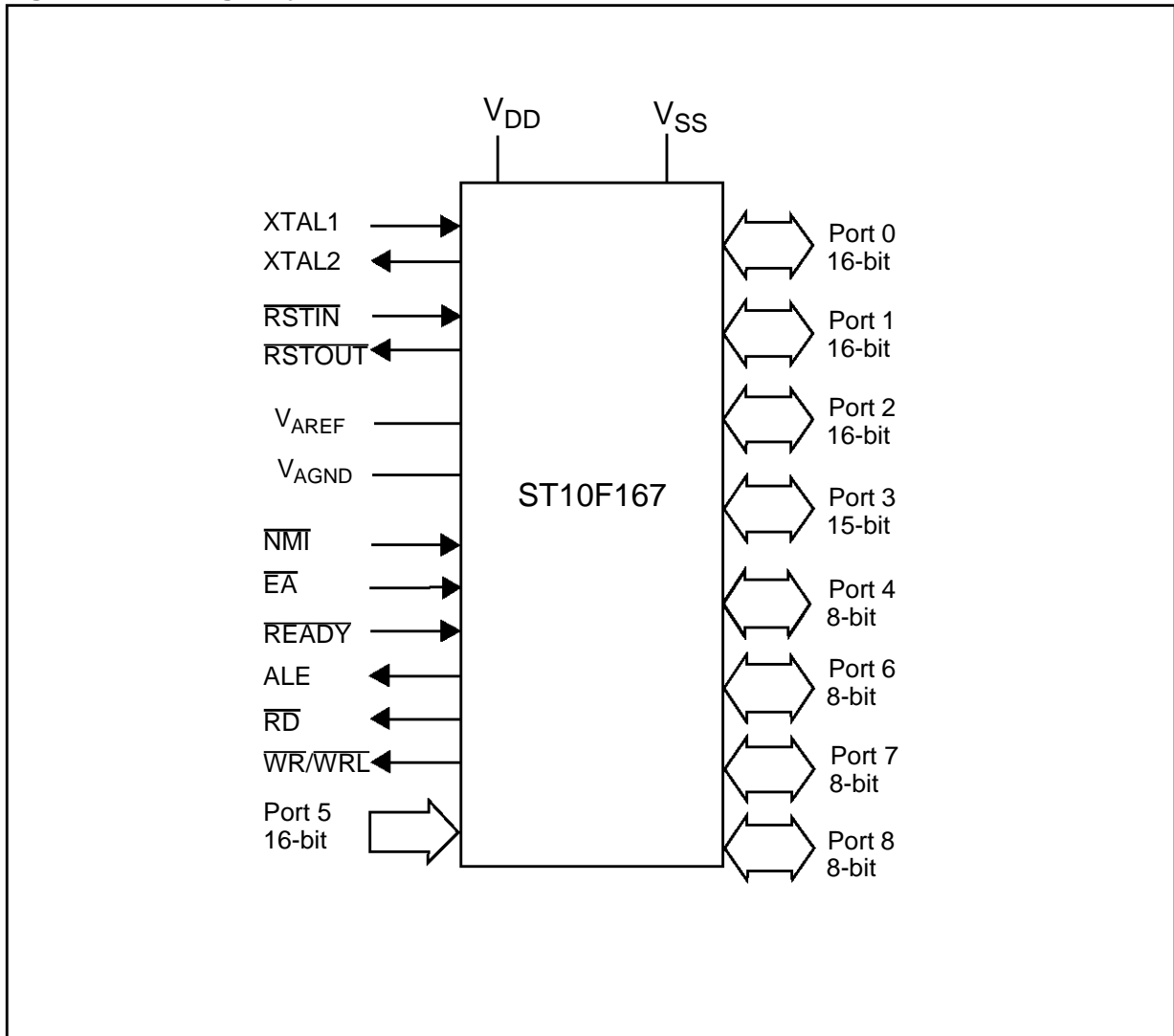

2 PIN DATA

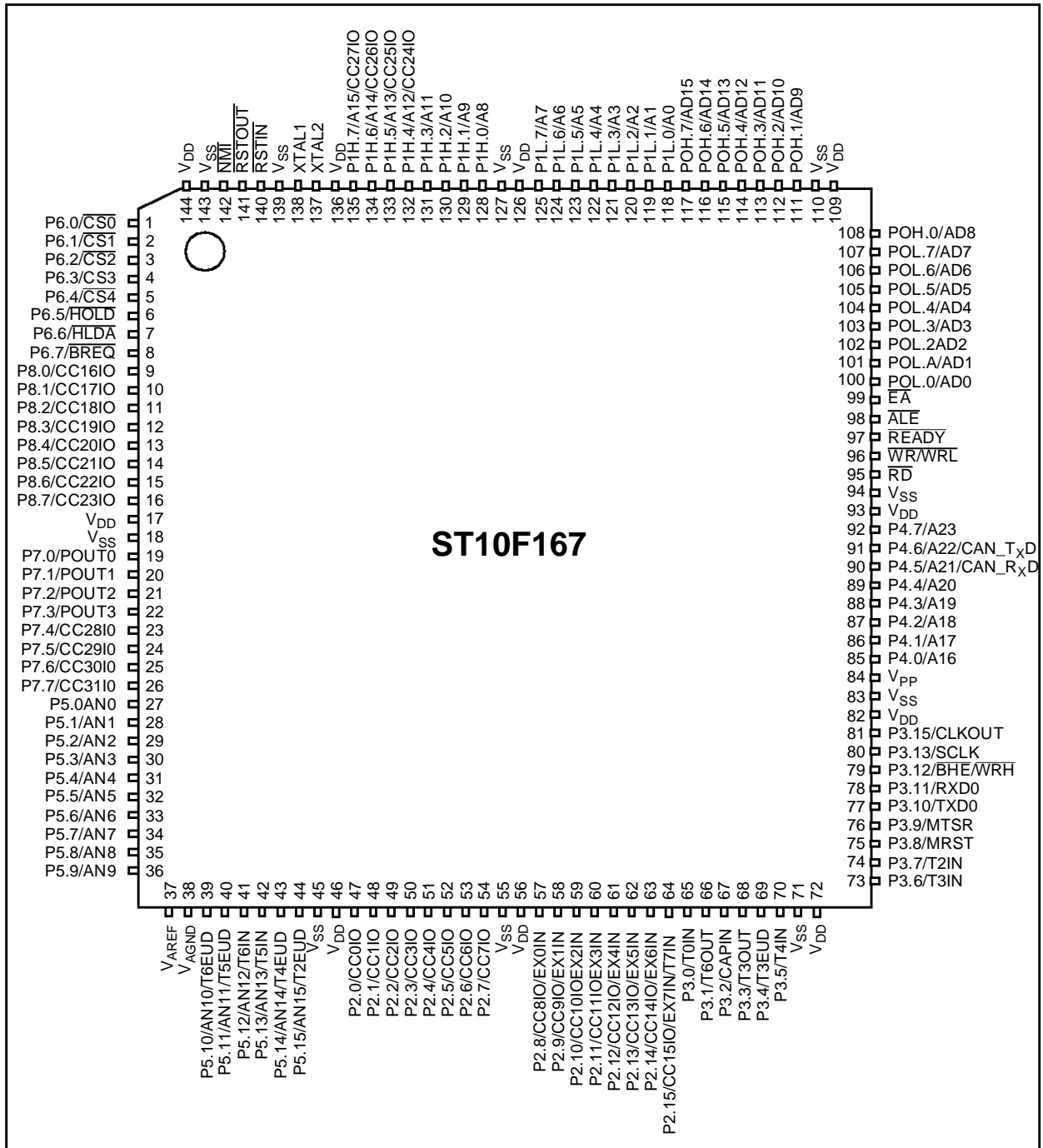

Table 2.1 Pin Definitions and Functions

Symbol	Pin Number	Input (I) Output (O)	Function
P6.0 – P6.7	1 - 8	I/O	Port 6 is an 8-bit bidirectional I/O port. It is bit-wise programmable for input or output via direction bits. For a pin configured as input, the output driver is put into high-impedance state. Port 6 outputs can be configured as push/pull or open drain drivers. The following Port 6 pins also serve for alternate functions:
	1	O	P6.0 $\overline{CS0}$ Chip Select 0 Output

	5	O	P6.4 $\overline{CS4}$ Chip Select 4 Output
	6	I	P6.5 \overline{HOLD} External Master Hold Request Input
	7	O	P6.6 \overline{HLDA} Hold Acknowledge Output
	8	O	P6.7 \overline{BREQ} Bus Request Output
	P8.0 – P8.7	9 - 16	I/O
9		I/O	P8.0 CC16IO CAPCOM2: CC16 Cap.-In/Comp.Out
...	
16		I/O	P8.7 CC23IO CAPCOM2: CC23 Cap.-In/Comp.Out
P7.0 – P7.7	19 - 26	I/O	Port 7 is an 8-bit bidirectional I/O port. It is bit-wise programmable for input or output via direction bits. For a pin configured as input, the output driver is put into high-impedance state. Port 7 outputs can be configured as push/pull or open drain drivers. The input threshold of Port 7 is selectable (TTL or special). The following Port 7 pins also serve for alternate functions:
	19	O	P7.0 POUT0 PWM Channel 0 Output

	22	O	P7.3 POUT3 PWM Channel 3 Output
	23	I/O	P7.4 CC28IO CAPCOM2: CC28 Cap.-In/Comp.Out

26	I/O	P7.7 CC31IO CAPCOM2: CC31 Cap.-In/Comp.Out	

Table 2.1 Pin Definitions and Functions (cont'd)

Symbol	Pin Number	Input (I) Output (O)	Function
P5.0-P5.15	27 – 36	I	Port 5 is a 16-bit input-only port with Schmitt-Trigger characteristics. The pins of Port 5 also serve as the (up to 16) analog input channels for the A/D converter, where P5.x equals ANx (Analog input channel x), or they serve as timer inputs: P5.10 T6EUD GPT2 Timer T6 Ext.Up/Down Ctrl.Input P5.11 T5EUD GPT2 Timer T5 Ext.Up/Down Ctrl.Input P5.12 T6IN GPT2 Timer T6 Count Input P5.13 T5IN GPT2 Timer T5 Count Input P5.14 T4EUD GPT1 Timer T4 Ext.Up/Down Ctrl.Input P5.15 T2EUD GPT1 Timer T2 Ext.Up/Down Ctrl.Input
	39 – 44	I	
	39	I	
	40	I	
	41	I	
	42	I	
	43	I	
	44	I	
P2.0-P2.15	47 – 54	I/O	Port 2 is a 16-bit bidirectional I/O port. It is bit-wise programmable for input or output via direction bits. For a pin configured as input, the output driver is put into high-impedance state. Port 2 outputs can be configured as push/pull or open drain drivers. The input threshold of Port 2 is selectable (TTL or special). The following Port 2 pins also serve for alternate functions: P2.0 CC0IO CAPCOM: CC0 Cap.-In/Comp.Out P2.7 CC7IO CAPCOM: CC7 Cap.-In/Comp.Out P2.8 CC8IO CAPCOM: CC8 Cap.-In/Comp.Out, EX0IN Fast External Interrupt 0 Input P2.15 CC15IO CAPCOM: CC15 Cap.-In/Comp.Out, EX7IN Fast External Interrupt 7 Input T7IN CAPCOM2 Timer T7 Count Input
	57 – 64	I/O	
	47	I/O	
	
	54	I/O	
	57	I/O	
	...	I	
	
	64	I/O	
	...	I	
...	I		

Table 2.1 Pin Definitions and Functions (cont'd)

Symbol	Pin Number	Input (I) Output (O)	Function
P3.0- P3.13, P3.15	65 – 70, 73 – 80, 81	I/O I/O I/O	<p>Port 3 is a 15-bit (P3.14 is missing) bidirectional I/O port. It is bit-wise programmable for input or output via direction bits. For a pin configured as input, the output driver is put into high-impedance state. Port 3 outputs can be configured as push/pull or open drain drivers. The input threshold of Port 3 is selectable (TTL or special).</p> <p>The following Port 3 pins also serve for alternate functions:</p>
	65	I	P3.0 T0IN CAPCOM Timer T0 Count Input
	66	O	P3.1 T6OUT GPT2 Timer T6 Toggle Latch Output
	67	I	P3.2 CAPIN GPT2 Register CAPREL Capture Input
	68	O	P3.3 T3OUT GPT1 Timer T3 Toggle Latch Output
	69	I	P3.4 T3EUD GPT1 Timer T3 Ext.Up/Down Ctrl.Input
	70	I	P3.5 T4IN GPT1 Timer T4 Input for Count/Gate/Reload/Capture
	73	I	P3.6 T3IN GPT1 Timer T3 Count/Gate Input
	74	I	P3.7 T2IN GPT1 Timer T2 Input for Count/Gate/Reload/Capture
	75	I/O	P3.8 MRST SSC Master-Rec./Slave-Transmit I/O
	76	I/O	P3.9 MTSR SSC Master-Transmit/Slave-Rec. O/I
	77	O	P3.10 TxD0 ASC0 Clock/Data Output (Asyn./Syn.)
	78	I/O	P3.11 RxD0 ASC0 Data Input (Asyn.) or I/O (Syn.)
	79	O	P3.12 $\overline{\text{BHE}}$ Ext. Memory High Byte Enable Signal,
		O	$\overline{\text{WRH}}$ Ext. Memory High Byte Write Strobe
	80	I/O	P3.13 SCLK SSC Master Clock Outp./Slave Cl. Inp.
	81	O	P3.15 CLKOUT System Clock Output (=CPU Clock)
P4.0 –P4.7	85 - 92	I/O	<p>Port 4 is an 8-bit bidirectional I/O port. It is bit-wise programmable for input or output via direction bits. For a pin configured as input, the output driver is put into high-impedance state.</p> <p>In case of an external bus configuration, Port 4 can be used to output the segment address lines:</p>
	85	O	P4.0 A16 Least Significant Segment Addr. Line
	90	O	P4.5 A21 Segment Address Line,
		I	CAN_RxD CAN Receive Data Input
	91	O	P4.6 A22 Segment Address Line,
		O	CAN_TxD CAN Transmit Data Output
	92	O	P4.7 A23 Most Significant Segment Addr. Line
$\overline{\text{RD}}$	95	O	External Memory Read Strobe. $\overline{\text{RD}}$ is activated for every external instruction or data read access.

Table 2.1 Pin Definitions and Functions (cont'd)

Symbol	Pin Number	Input (I) Output (O)	Function
$\overline{WR}/\overline{WRL}$	96	O	External Memory Write Strobe. In \overline{WR} -mode this pin is activated for every external data write access. In \overline{WRL} -mode this pin is activated for low byte data write accesses on a 16-bit bus, and for every data write access on an 8-bit bus. See WRCFG in register SYSCON for mode selection.
READY	97	I	Ready Input. When the Ready function is enabled, a high level at this pin during an external memory access will force the insertion of memory cycle time waitstates until the pin returns to a low level.
ALE	98	O	Address Latch Enable Output. Can be used for latching the address into external memory or an address latch in the multiplexed bus modes.
\overline{EA}	99	I	External Access Enable pin. A low level at this pin during and after Reset forces the ST10F167 to begin instruction execution out of external memory. A high level forces execution out of the internal Flash Memory.
PORT0: POL.0- POL.7, POH.0- POH.7	100-107 108, 111-117	I/O	<p>PORT0 consists of the two 8-bit bidirectional I/O ports POL and POH. It is bit-wise programmable for input or output via direction bits. For a pin configured as input, the output driver is put into high-impedance state.</p> <p>In case of an external bus configuration, PORT0 serves as the address (A) and address/data (AD) bus in multiplexed bus modes and as the data (D) bus in demultiplexed bus modes.</p> <p>Demultiplexed bus modes: Data Path Width:8-bit 16-bit POL.0 – POL.7:D0 – D7D0 - D7 POH.0 – POH.7:I/O D8 - D15</p> <p>Multiplexed bus modes: Data Path Width:8-bit 16-bit POL.0 – POL.7:AD0 – AD7AD0 - AD7 POH.0 – POH.7:A8 - A15AD8 - AD15</p>

Table 2.1 Pin Definitions and Functions (cont'd)

Symbol	Pin Number	Input (I) Output (O)	Function
PORT1: P1L.0 – P1L.7, P1H.0 - P1H.7	118 – 125 128 – 135	I/O	PORT1 consists of the two 8-bit bidirectional I/O ports P1L and P1H. It is bit-wise programmable for input or output via direction bits. For a pin configured as input, the output driver is put into high-impedance state. PORT1 is used as the 16-bit address bus (A) in demultiplexed bus modes and also after switching from a demultiplexed bus mode to a multiplexed bus mode. The following PORT1 pins also serve for alternate functions:
	132	I	P1H.4 CC24IO CAPCOM2: CC24 Capture Input
	133	I	P1H.5 CC25IO CAPCOM2: CC25 Capture Input
	134	I	P1H.6 CC26IO CAPCOM2: CC26 Capture Input
	135	I	P1H.7 CC27IO CAPCOM2: CC27 Capture Input
XTAL1	138	I	XTAL1: Input to the oscillator amplifier and input to the internal clock generator
XTAL2	137	O	XTAL2: Output of the oscillator amplifier circuit. To clock the device from an external source, drive XTAL1, while leaving XTAL2 unconnected. Minimum and maximum high/low and rise/fall times specified in the AC Characteristics must be observed.
RSTIN	140	I	Reset Input with Schmitt-Trigger characteristics. A low level at this pin for a specified duration while the oscillator is running resets the ST10F167. An internal pullup resistor permits power-on reset using only a capacitor connected to V_{SS} .
RSTOUT	141	O	Internal Reset Indication Output. This pin is set to a low level when the part is executing, either a hardware, a software or a watchdog timer reset. RSTOUT remains low until the EINIT (end of initialization) instruction is executed.
NMI	142	I	Non-Maskable Interrupt Input. A high to low transition at this pin causes the CPU to vector to the NMI trap routine. When the PWRDN (power down) instruction is executed, the $\overline{\text{NMI}}$ pin must be low in order to force the ST10F167 to go into power down mode. If $\overline{\text{NMI}}$ is high, when PWRDN is executed, the part will continue to run in normal mode. If not used, pin $\overline{\text{NMI}}$ should be pulled high externally.
V_{AREF}	37	-	Reference voltage for the A/D converter.
V_{AGND}	38	-	Reference ground for the A/D converter.
V_{PP}	84	-	Flash programming voltage. This pin accepts the programming voltage for the on-chip flash EPROM of the ST10F167.

Table 2.1 Pin Definitions and Functions (cont'd)

Symbol	Pin Number	Input (I) Output (O)	Function
V_{DD}	46, 82, 136	-	Digital Supply Voltage for internal circuitry: + 5 V during normal operation and idle mode. ≥ 2.5 V during power down mode
	17, 56, 72, 93, 109,126, 144	-	Digital Supply Voltage for port drivers: + 5 V during normal operation and idle mode
V_{SS}	45, 83, 139	-	Digital Ground for internal circuitry.
	18, 55, 71, 94, 110,127, 143	-	Digital Ground for port drivers.

4 MEMORY ORGANIZATION

The memory space of the ST10F167 is configured in a Von-Neumann architecture. Code memory, data memory, registers and I/O ports are organized within the same linear address space which includes 16 MBytes. The entire memory space can be accessed bitwise or wordwise. Particular portions of the on-chip memory have additionally been made directly bit addressable.

The ST10F167 provides 128KBytes of on-chip flash memory.

2 KBytes of on-chip Internal RAM are provided as a storage for user defined variables, for the system stack, general purpose register banks and even for code. A register bank can consist of up to 16 worldwide (R0 to R15) and/or bitwise (RL0, RH0, ..., RL7, RH7) so-called General Purpose Registers (GPRs).

1024 bytes (2 * 512 bytes) of the address space are reserved for the Special Function Register areas (SFR space and ESFR space). SFRs are worldwide registers which are used for controlling and monitoring functions of the different on-chip units. Unused SFR addresses are reserved for other/future members of the ST10 family.

2 KBytes of on-chip Extension RAM (XRAM) are provided to store user data, user stacks or code. The XRAM is accessed like external memory and cannot be used for the system stack or register banks, and is not bit-addressable. The XRAM allows 16-bit accesses with maximum speed.

In order to meet the needs of designs where more memory is required than is provided on chip, up to 16 MBytes of external RAM and/or ROM can be connected to the microcontroller.

5 EXTERNAL BUS CONTROLLER

All of the external memory accesses are performed by a particular on-chip External Bus Controller (EBC). It can be programmed either to Single Chip Mode when no external memory is required, or to one of four different external memory access modes, which are as follows:

- 16-/18-/20-/24-bit Addresses, 16-bit Data, Demultiplexed
- 16-/18-/20-/24-bit Addresses, 16-bit Data, Multiplexed
- 16-/18-/20-/24-bit Addresses, 8-bit Data, Multiplexed
- 16-/18-/20-/24-bit Addresses, 8-bit Data, Demultiplexed

In the demultiplexed bus modes, addresses are output on PORT1 and data is input/output on PORT0. In the multiplexed bus modes both addresses and data use PORT0 for input/output.

Important timing characteristics of the external bus interface (Memory Cycle Time, Memory Tri-State Time, Length of ALE and Read Write Delay) have been made programmable. This gives the choice of a wide range of different types of memories and external peripherals. In addition, different address ranges may be accessed with different bus characteristics. Up to 5 external \overline{CS} signals (4 windows plus default) can be generated in order to save external glue logic. Access to very slow memories is supported via a particular 'Ready' function. A $\overline{HOLD}/\overline{HLDA}$ protocol is available for bus arbitration.

For applications which require less than 16 MBytes of external memory space, this address space can be restricted to 1 MByte, 256 KByte or to 64 KByte. In this case Port 4 outputs four, two or no address lines. If an address space of 16 MBytes is used, it outputs all 8 address lines.

6 FLASH MEMORY

The ST10F167 provides 128KBytes of on-chip, electrically erasable and re-programmable Flash EPROM. The flash memory is organized in 32 bit wide blocks. This allows double word instructions to be fetched in one machine cycle. The flash memory can be used for both code and data storage. The flash memory is organised into four banks of sizes 8K, 24K, 48K and 48Kbytes (table 6.1). Each of these banks can be erased independently. This prevents unnecessary re-programming of the whole flash memory when only a partial re-programming is required.

The first 32K bytes of the FLASH memory are located in segment 0 (0h to 007FFFh) during reset, and include the reset and interrupt vectors. The rest of the FLASH memory is mapped in segments 1 and 2 (018000h to 02FFFFh). For flexibility, the first 32K bytes of the FLASH memory may be remapped to segment 1 (010000h to 017FFFh) during initialization. This allows the interrupt vectors to be programmed from the external memory, while retaining the common routines and constants that are programmed into the FLASH memory.

Table 6.1 FLASH Memory Bank Organisation

Bank	Addresses (Segment 0)	Size (bytes)
0	000000h to 07FFFh and 018000h to 01BFFFh	48K
1	01C000h to 027FFFh	48K
2	028000h to 02DFFFh	24K
3	02E000h to 02FFFFh	8K

6.1 Flash Memory Programming And Erasure

The FLASH memory is programmed using the PRESTO F Program Write algorithm. Erasure of the FLASH memory is performed in the program mode using the PRESTO F Erase algorithm.

Timing of the Write/Erase cycles is automatically generated by a programmable timer and comple-

tion is indicated by a flag. A second flag indicates that the V_{PP} voltage was correct for the whole programming cycle. This guarantees that a good write/erase operation has been carried out.

The FLASH parameters are detailed below.

Table 6.2 Flash Parameters

Parameter	Units	Min	Typical	Max
Word Programming Time	μsec	12.8	12.8	1250
Bank Erasing Time	sec		0.5	30
Endurance	cycles	1000		
Flash Vpp	volts	11.4		12.6

6.2 Flash Control Register (FCR)

In the standard operation mode, the FLASH memory can be accessed in the same way as the normal mask-programmable on-chip ROM. All, appropriate, direct and indirect addressing modes can be used for reading the FLASH memory.

All programming or erase operations are controlled via a 16-bit register, the FCR. The FCR is not an SFR or GPR. To prevent inadvertent writing to the FLASH memory, the FCR is locked and inactive during the standard operation mode. The FLASH memory writing mode must be entered, before a valid access to the FCR is provided. This is done via a special key code instruction sequence.

The FCR is virtually mapped into the active address space of the Flash memory. It can only be accessed with direct 16-bit (mem) addressing modes. Since the FCR is neither byte, nor bit-addressable, only word operand instructions can be used for FCR accesses. By default, the FCR can be accessed with any even address from 000000h to 07FFFEh and 018000h to 02FFFEh. If the first 32K byte Block of the FLASH memory is mapped to segment 1, the corresponding even FCR addresses are 010000h to 017FFEh. Note that DPP referencing and DPP contents must be considered for FCR accesses. If an FCR access is attempted via an odd address, an illegal operand access hardware trap will occur.

FCR

Flash Control Register

Reset Condition: 0000h (Read)

b15 = **FWMSET**: *Flash Writing Mode Set*. This bit is set to "1" automatically once the Flash writing mode is entered. To exit from the Flash writing mode, FWMSET must be set to "0". Since only word values can be written to FCR, care must be taken that FWMSET is not cleared inadvertently. Therefore, for any command written to FCR (except for the return to the Flash standard mode),

FWMSET must be set to "1". Reset condition of FWMSET is "0".

b14-b10 = **Reserved**: these bits are reserved for future development, they must be written to "0".

b9-b8 = **BE0,1**: *Bank erase select*. These bits select the Flash memory bank to be erased. The physical addresses of bank 0 depends on the which Flash memory map has been chosen. In Flash operating modes, other than the erasing mode, these bits are not significant. At reset BE1,0 are set to "00".

b7 = **WDWW**: *Word/double word write*. This bit determines the word width used for programming operations: 16-bit (WDWW = 0) or 32-bit (WDWW = "1"). In Flash operation modes, other than the programming mode, this bit is not significant. At reset, WDWW is set to "0".

b6-b5 = **CKCTL0,1**: *Flash Timer Clock Control*. These two bits control the width (TPRG) of the programming or erase pulses applied to the Flash memory cells during the operation. TPRG varies in an inverse ratio to the clock frequency. To avoid putting the Flash memory under critical stress conditions, the width of one single programming or erase pulse and the programming or erase time, must not exceed defined values. Thus the maximum number of programming or erase attempts, depends on the system clock frequency.

RESET state: 00.

b4 = **VPPRIV**: *V_{PP} Revelation bit*. This read-only bit reflects the state of the V_{PP} voltage in the Flash writing mode. If VPPRIV is set to "0", this indicates that V_{PP} is below the threshold necessary for reliable programming. The normal reaction to this indication is to check the V_{PP} power supply and to then repeat the intended operation. If the V_{PP} voltage is above a sufficient margin, VPPRIV will be set to "1". The reset state of the VPPRIV bit depends on the state of the external V_{PP} voltage at the V_{PP} pin.

b3 = **FCVPP**: *Flash V_{PP} control bit*. This read-only bit indicates that the V_{PP} voltage fell below the valid threshold value during a Flash programming or erase operation. If FCVPP is set to "1" after such an operation has finished, it can mean that the operation was not successful. The V_{PP} power supply should be checked and the operation repeated. If FCVPP is set to "0", no critical discontinuity in V_{PP} occurred. At reset FCVPP is set to "0".

b2 = **FBUSY**: *Flash busy bit*. This read-only bit indicates that a Flash programming or erase operation is in progress. FBUSY is set to "1" by hardware, as soon as the programming or erase command is given. At reset FBUSY is set to "0". Note that this bit position is also occupied by the write-only bit RPROT.

b2 = **RPROT**: *Protection enable bit*. This bit set at 1, anded with the OTP protection bit, disables any access to the Flash, by instructions fetched from the external memory space, or from the internal RAM. This write-only bit, is only significant if the general Flash memory protection is enabled. If the protection is enabled, the setting of RPROT determines whether the Flash protection is active (RPROT="1") or inactive (RPROT="0"). RPROT is the only FCR bit which can be modified even in the Flash standard operation mode, but only by an in-

struction executed from the Flash memory itself. At reset, RPROT is set to "1". Note that this bit position is also occupied by the read-only bit FBUSY.

b1 = **FEE**: *Flash erase/program selection*. This bit selects the Flash write operation to be performed: erase (FEE="1") or programming (FEE="0"). Together with bits FWE and FWMSET, bit FEE determines the operation mode of the Flash memory. Note that setting bits FWE and FEE causes the corresponding Flash operation mode to be selected but does not launch the execution of the selected operation. If bit FWE was set to "0", the setting of FEE is insignificant. At reset, FEE is set to "0".

b0 = **FWE**: *Flash write/read enable*. This bit determines whether FLASH write operations are enabled (FWE=1) or disabled (FWE=0). By definition, a FLASH write operation can be either programming or erasure. Together with bits FEE and FWMSET, bit FWE determines the operation mode of the Flash memory. Note that setting bits FWE and FEE causes the corresponding Flash operation mode to be selected but does not launch the execution of the selected operation. If bit FWE was set to "1", any read access on a Flash memory location means a particular program-verify or erase-verify read operation. Flash write operations are disabled at reset.

6.3 Flash Memory Security

Security and reliability have been enhanced by built-in features: a key code sequence is used to enter the Write/Erase mode preventing false write cycles, a programmable option (set by the programming board) prevents access to the FLASH memory from the internal RAM or from External

Memory. If the security option is set, the FLASH memory can only be accessed from a program within the FLASH memory area. This protection can only be disabled by instructions executed from the FLASH memory.

Figure 6.1 PRESTO F Write Algorithm

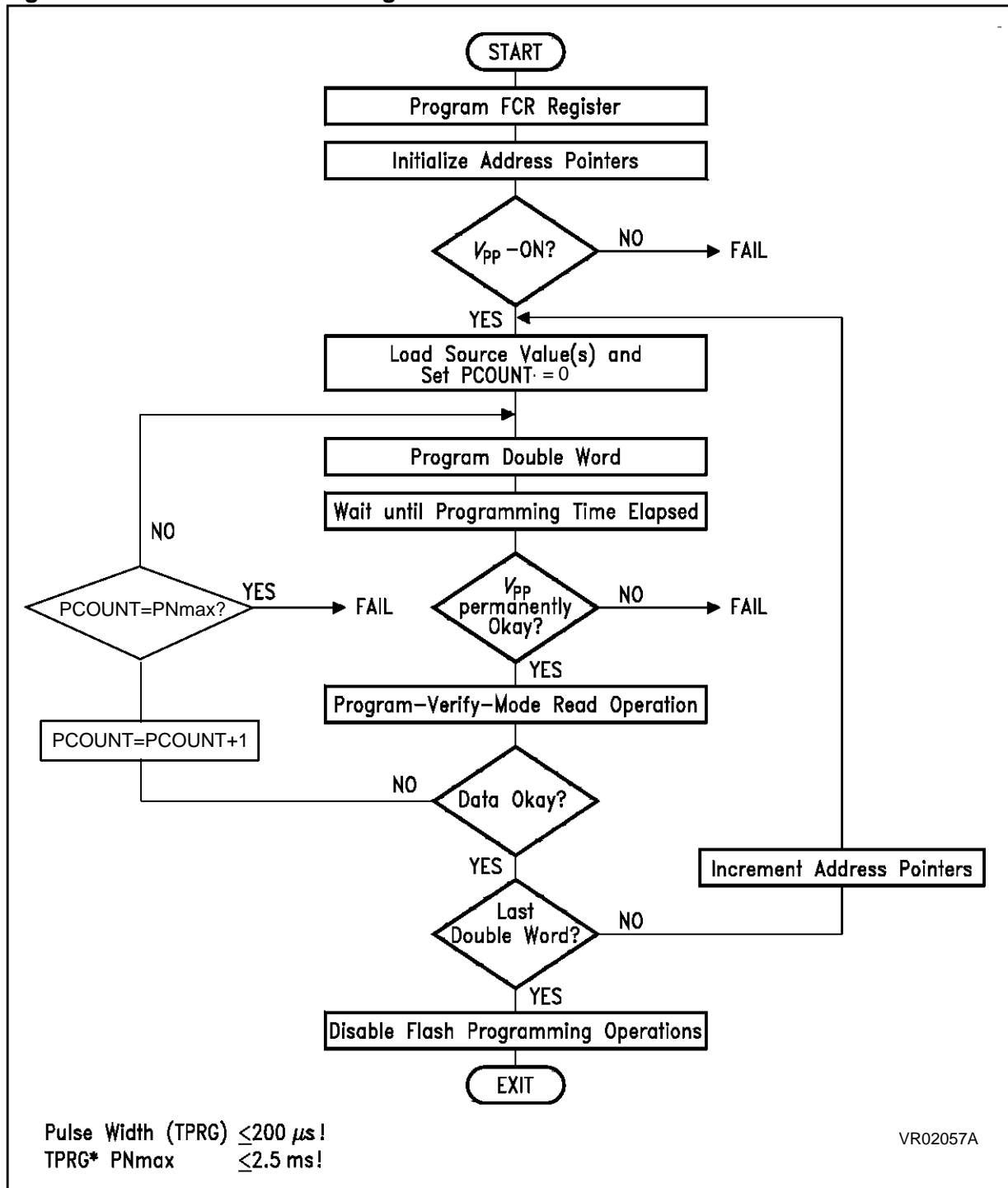
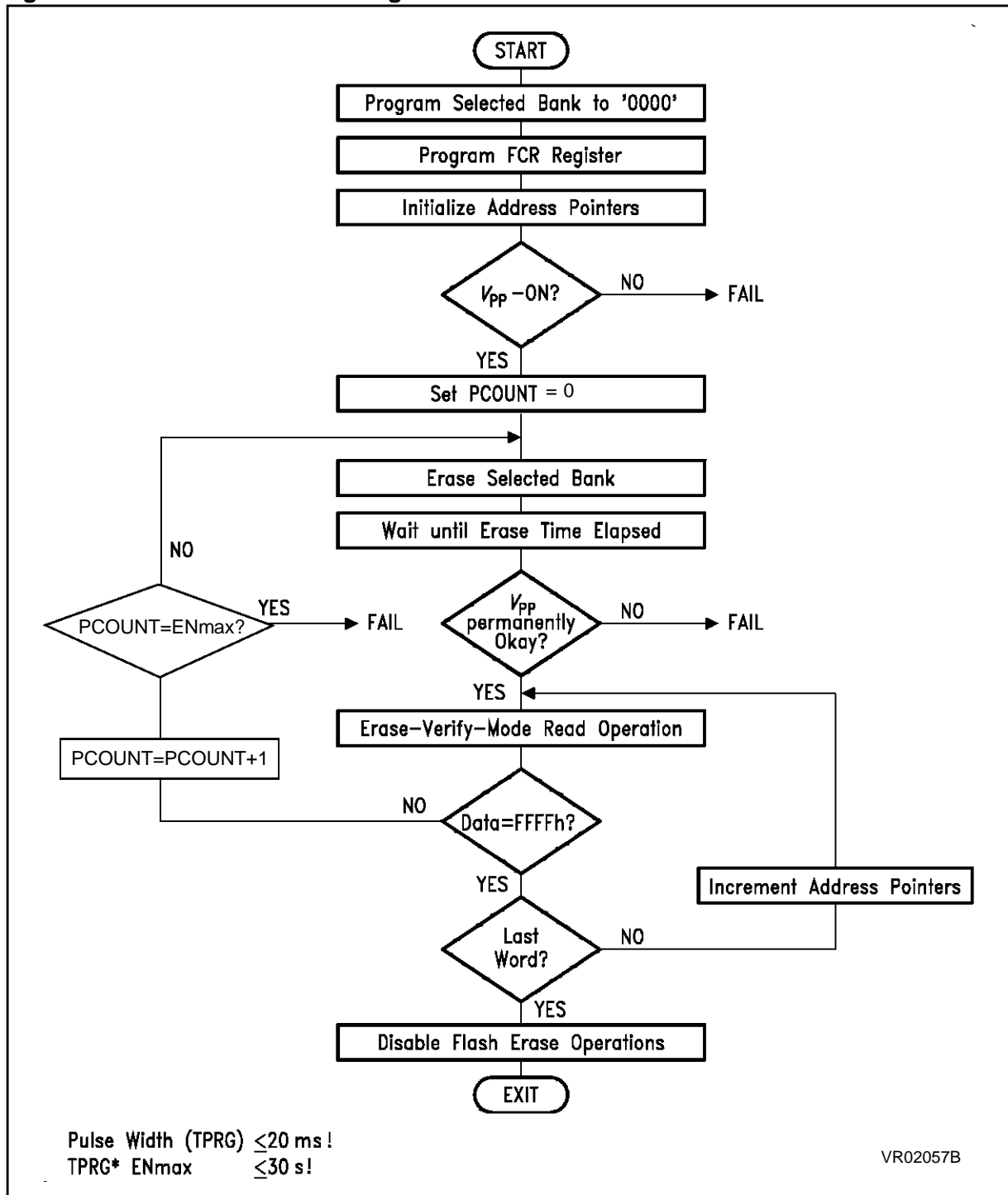
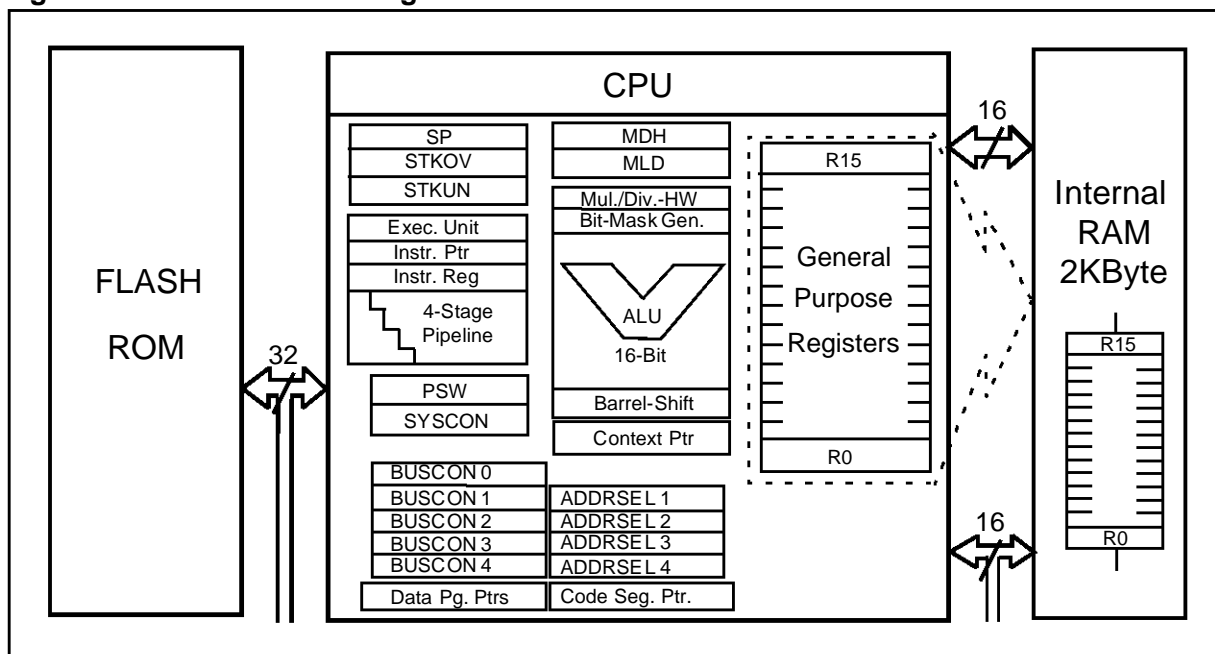

Figure 6.2 PRESTO F Erase Algorithm



7 CENTRAL PROCESSING UNIT (CPU)

Figure 7.1 CPU Block Diagram



The main core of the CPU consists of a 4-stage instruction pipeline, a 16-bit arithmetic and logic unit (ALU) and dedicated SFRs. has been added for a separate multiply and divide unit, a bit-mask generator and a barrel shifter.

Based on these hardware provisions, most of the ST10F167's instructions can be executed in one machine cycle. This requires 100ns at 20MHz CPU clock. For example, shift and rotate instructions are always processed during one machine cycle independent of the number of bits to be shifted. All multiple-cycle instructions have been optimized for speed: branches in 2 cycles, a 16×16 bit multiplication in 5 cycles and a $32/16$ bit division in 10 cycles. The 'Jump Cache' pipeline optimization, reduces the execution time of repeatedly performed jumps in a loop, from 2 cycles to 1 cycle.

The CPU includes an actual register context. This consists of up to 16 worldwide GPRs which are physically allocated within the on-chip RAM area. A Context Pointer (CP) register determines the base address of the active register bank to be accessed by the CPU at a time. The number of register banks is only restricted by the available internal RAM space. For easy parameter passing, a register bank may overlap others.

A system stack of up to 2048 bytes is provided as a storage for temporary data. The system stack is allocated in the on-chip RAM area, and it is accessed by the CPU via the stack pointer (SP) register. Two separate SFRs, STKOV and STKUN, are implicitly compared against the stack pointer value upon each stack access for the detection of a stack overflow or underflow.

An efficient instruction set allows maximum use of the CPU. The instruction set is classified into the following groups:

- Arithmetic Instructions
- Logical Instructions
- Boolean Bit Manipulation Instructions
- Compare and Loop Control Instructions
- Shift and Rotate Instructions
- Prioritize Instruction
- Data Movement Instructions
- System Stack Instructions
- Jump and Call Instructions
- Return Instructions
- System Control Instructions
- Miscellaneous Instructions

The basic instruction length is either 2 or 4 bytes. Possible operand types are bits, bytes and words. A variety of direct, indirect or immediate addressing modes exist.

8 INTERRUPT SYSTEM

With an interrupt response time from 250ns to 600ns (in the case of internal program execution), the ST10F167 reacts quickly to the occurrence of non-deterministic events

The architecture of the ST10F167 supports several mechanisms for fast and flexible response to service requests that can be generated from various sources internal or external to the microcontroller. Any of these interrupt requests can be programmed to being serviced by the Interrupt Controller or by the Peripheral Event Controller (PEC).

In a standard interrupt service, program execution is suspended and a branch to the interrupt vector table is performed. For a PEC service, just one cycle is 'stolen' from the current CPU activity. A PEC service is a single byte or word data transfer between any two memory locations with an additional increment of either the PEC source or the destination pointer. An individual PEC transfer counter is decremented for each PEC service, except for the continuous transfer mode. When this counter reaches zero, a standard interrupt is performed to the corresponding source related vector location. PEC services are suited to, for example, the transmission or reception of blocks of data. The

ST10F167 has 8 PEC channels, each of which offers fast interrupt-driven data transfer capabilities.

A separate control register which contains an interrupt request flag, an interrupt enable flag and an interrupt priority bitfield, exists for each of the possible interrupt sources. Via its related register, each source can be programmed to one of sixteen interrupt priority levels. Once having been accepted by the CPU, an interrupt service can only be interrupted by a higher prioritized service request. For the standard interrupt processing, each of the possible interrupt sources has a dedicated vector location.

Fast external interrupt inputs are provided to service external interrupts with high precision requirements. These fast interrupt inputs, feature programmable edge detection (rising edge, falling edge or both edges).

Software interrupts are supported by means of the 'TRAP' instruction in combination with an individual trap (interrupt) number.

Table 8.1 shows all of the possible ST10F167 interrupt sources and the corresponding hardware-related interrupt flags, vectors, vector locations and trap (interrupt) numbers

Table 8.1 Interrupt Sources, Flags, Vector and Trap Numbers

Source of Interrupt or PEC Service Request	Request Flag	Enable Flag	Interrupt Vector	Vector Location	Trap Number
CAPCOM Register 0	CC0IR	CC0IE	CC0INT	00'0040h	10h
CAPCOM Register 1	CC1IR	CC1IE	CC1INT	00'0044h	11h
CAPCOM Register 2	CC2IR	CC2IE	CC2INT	00'0048h	12h
CAPCOM Register 3	CC3IR	CC3IE	CC3INT	00'004Ch	13h
CAPCOM Register 4	CC4IR	CC4IE	CC4INT	00'0050h	14h
CAPCOM Register 5	CC5IR	CC5IE	CC5INT	00'0054h	15h
CAPCOM Register 6	CC6IR	CC6IE	CC6INT	00'0058h	16h
CAPCOM Register 7	CC7IR	CC7IE	CC7INT	00'005Ch	17h
CAPCOM Register 8	CC8IR	CC8IE	CC8INT	00'0060h	18h
CAPCOM Register 9	CC9IR	CC9IE	CC9INT	00'0064h	19h
CAPCOM Register 10	CC10IR	CC10IE	CC10INT	00'0068h	1Ah
CAPCOM Register 11	CC11IR	CC11IE	CC11INT	00'006Ch	1Bh
CAPCOM Register 12	CC12IR	CC12IE	CC12INT	00'0070h	1Ch
CAPCOM Register 13	CC13IR	CC13IE	CC13INT	00'0074h	1Dh
CAPCOM Register 14	CC14IR	CC14IE	CC14INT	00'0078h	1Eh
CAPCOM Register 15	CC15IR	CC15IE	CC15INT	00'007Ch	1Fh
CAPCOM Register 16	CC16IR	CC16IE	CC16INT	00'00C0h	30h
CAPCOM Register 17	CC17IR	CC17IE	CC17INT	00'00C4h	31h
CAPCOM Register 18	CC18IR	CC18IE	CC18INT	00'00C8h	32h
CAPCOM Register 19	CC19IR	CC19IE	CC19INT	00'00CCh	33h
CAPCOM Register 20	CC20IR	CC20IE	CC20INT	00'00D0h	34h
CAPCOM Register 21	CC21IR	CC21IE	CC21INT	00'00D4h	35h
CAPCOM Register 22	CC22IR	CC22IE	CC22INT	00'00D8h	36h
CAPCOM Register 23	CC23IR	CC23IE	CC23INT	00'00DCh	37h
CAPCOM Register 24	CC24IR	CC24IE	CC24INT	00'00E0h	38h
CAPCOM Register 25	CC25IR	CC25IE	CC25INT	00'00E4h	39h
CAPCOM Register 26	CC26IR	CC26IE	CC26INT	00'00E8h	3Ah
CAPCOM Register 27	CC27IR	CC27IE	CC27INT	00'00ECh	3Bh
CAPCOM Register 28	CC28IR	CC28IE	CC28INT	00'00E0h	3Ch
CAPCOM Register 29	CC29IR	CC29IE	CC29INT	00'0110h	44h
CAPCOM Register 30	CC30IR	CC30IE	CC30INT	00'0114h	45h
CAPCOM Register 31	CC31IR	CC31IE	CC31INT	00'0118h	46h
CAPCOM Timer 0	T0IR	T0IE	T0INT	00'0080h	20h
CAPCOM Timer 1	T1IR	T1IE	T1INT	00'0084h	21h
CAPCOM Timer 7	T7IR	T7IE	T7INT	00'00F4h	3Dh
CAPCOM Timer 8	T8IR	T8IE	T8INT	00'00F8h	3Eh

Table 8.1 Interrupt Sources, Flags, Vector and Trap Numbers (cont'd)

Source of Interrupt or PEC Service Request	Request Flag	Enable Flag	Interrupt Vector	Vector Location	Trap Number
GPT1 Timer 2	T2IR	T2IE	T2INT	00'0088h	22h
GPT1 Timer 3	T3IR	T3IE	T3INT	00'008Ch	23h
GPT1 Timer 4	T4IR	T4IE	T4INT	00'0090h	24h
GPT2 Timer 5	T5IR	T5IE	T5INT	00'0094h	25h
GPT2 Timer 6	T6IR	T6IE	T6INT	00'0098h	26h
GPT2 CAPREL Register	CRIR	CRIE	CRINT	00'009Ch	27h
A/D Conversion Complete	ADCIR	ADCIE	ADCINT	00'00A0h	28h
A/D Overrun Error	ADEIR	ADEIE	ADEINT	00'00A4h	29h
ASC0 Transmit	S0TIR	S0TIE	S0TINT	00'00A8h	2Ah
ASC0 Transmit Buffer	S0TBIR	S0TBIE	S0TBINT	00'011Ch	47h
ASC0 Receive	S0RIR	S0RIE	S0RINT	00'00ACh	2Bh
ASC0 Error	S0EIR	S0EIE	S0EINT	00'00B0h	2Ch
SSC Transmit	SCTIR	SCTIE	SCTINT	00'00B4h	2Dh
SSC Receive	SCRIR	SCRIE	SCRINT	00'00B8h	2Eh
SSC Error	SCEIR	SCEIE	SCEINT	00'00BCh	2Fh
PWM Channel 0...3	PWMIR	PWMIE	PWMINT	00'00FCh	3Fh
CAN Interface	XP0IR	XP0IE	XP0INT	00'0100h	40h
X-Peripheral Node	XP1IR	XP1IE	XP1INT	00'0104h	41h
X-Peripheral Node	XP2IR	XP2IE	XP2INT	00'0108h	42h
PLL Unlock	XP3IR	XP3IE	XP3INT	00'010Ch	43h

Note: Two X-Peripheral nodes can accept interrupt requests from integrated X-Bus peripherals. Nodes, where no X-Peripherals are connected, may be used to generate software controlled interrupt requests by setting the respective XPhIR bit.

The ST10F167 provides an excellent mechanism to identify and to process exceptions or error conditions that arise during run-time, 'Hardware Traps'. Hardware traps cause an immediate non-maskable system reaction which is similar to a standard interrupt service (branching to a dedicated vector table location). The occurrence of a hardware trap is additionally signified by an individual bit in the trap flag register (TFR). Except

when another higher prioritized trap service is in progress, a hardware trap will interrupt any actual program execution. In turn, hardware trap services can normally not be interrupted by standard or PEC interrupts

Table 8.2 shows all of the possible exceptions or error conditions that can arise during run-time.

Table 8.2 Exceptions or Error Conditions During Runtime

Exception Condition	Trap Flag	Trap Vector	Vector Location	Trap Number	Trap Priority
Reset Functions: •Hardware Reset •Software Reset •Watchdog Timer Overflow		RESET RESET RESET	00'0000h 00'0000h 00'0000h	00h 00h 00h	III III III
Class A Hardware Traps: •Non-Maskable Interrupt •Stack Overflow •Stack Underflow	NMI STKOF STKUF	NMITRAP STOTRP STUTRP	00'0008h 00'0010h 00'0018h	02h 04h 06h	II II II
Class B Hardware Traps: •Undefined Opcode •Protected Instruction Fault •Illegal Word Operand Access •Illegal Instruction Access •Illegal External Bus Access	UNDOPC PRTFLT ILLOPA ILLINA ILLBUS	BTRAP BTRAP BTRAP BTRAP BTRAP	00'0028h 00'0028h 00'0028h 00'0028h 00'0028h	0Ah 0Ah 0Ah 0Ah 0Ah	I I I I I
Reserved			[2Ch – 3Ch]	[0Bh – 0Fh]	
Software Traps •TRAP Instruction			Any [00'0000h – 00'01FCh] in steps of 4h	Any [00h – 7Fh]	Current CPU Priority

9 CAPTURE/COMPARE (CAPCOM) UNITS

The CAPCOM units support generation and control of timing sequences on up to 32 channels. It has a maximum resolution of 400 ns at 20MHz system clock. The CAPCOM units are typically used to handle high speed I/O tasks such as pulse and waveform generation, pulse width modulation (PMW), Digital to Analog (D/A) conversion, software timing, or time recording relative to external events.

Four 16-bit timers (T0/T1, T7/T8) with reload registers, provide two independent time bases for the capture/compare register array.

The input clock for the timers is programmable to several pre-scaled values of the internal system clock, or may be derived from an overflow/underflow of timer T6 in module GPT2. This provides a wide range of variation for the timer period and resolution and allows precise adjustments to the application specific requirements. In addition, external count inputs for CAPCOM timers T0 and T7 allow event scheduling for the capture/compare registers relative to external events.

Both of the two capture/compare register arrays contain 16 dual purpose capture/compare regis-

ters, each of which may be individually allocated to either CAPCOM timer T0 or T1 (T7 or T8, respectively), and programmed for capture or compare function. Each register has one port pin associated with it which serves as an input pin for triggering the capture function, or as an output pin (except for CC24...CC27) to indicate the occurrence of a compare event.

When a capture/compare register has been selected for capture mode, the current contents of the allocated timer will be latched ('captured') into the capture/compare register in response to an external event at the port pin which is associated with this register. In addition, a specific interrupt request for this capture/compare register is generated. Either a positive, a negative, or both a positive and a negative external signal transition at the pin can be selected as the triggering event. The contents of all registers which have been selected for one of the five compare modes are continuously compared with the contents of the allocated timers. When a match occurs between the timer value and the value in a capture/compare register, specific actions will be taken, based on the selected compare mode.

Table 9.1 Compare Mode Function

Compare Modes	Function
Mode 0	Interrupt-only compare mode; several compare interrupts per timer period are possible
Mode 1	Pin toggles on each compare match; several compare events per timer period are possible
Mode 2	Interrupt-only compare mode; only one compare interrupt per timer period is generated
Mode 3	Pin set '1' on match; pin reset '0' on compare time overflow; only one compare event per timer period is generated
Double Register Mode	Two registers operate on one pin; pin toggles on each compare match; several compare events per timer period are possible.

Figure 9.1 CAPCOM Unit Block Diagram

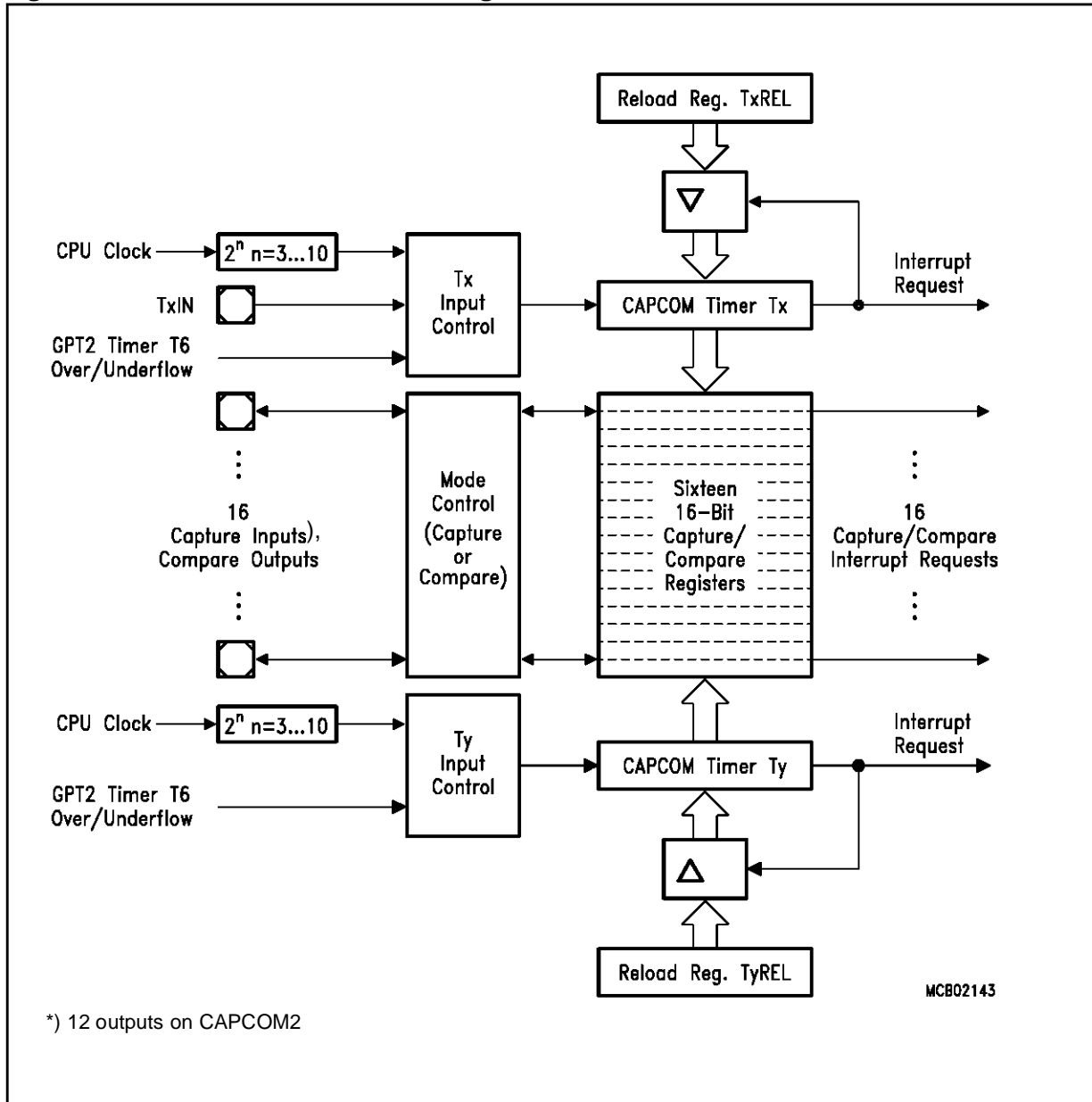

10 GENERAL PURPOSE TIMER (GPT) UNIT

The GPT unit is a flexible multifunctional timer/counter structure. It may be used for many different time-related tasks such as: event timing and counting, pulse width and duty cycle measurements, pulse generation or pulse multiplication.

The GPT unit incorporates five 16-bit timers which are organized in two separate modules, GPT1 and GPT2. Each timer, in each module may operate independently in a number of different modes, or may be concatenated with another timer of the same module.

Each of the three timers T2, T3, T4 of module GPT1 can be configured individually for one of three basic modes of operation: Timer, Gated Timer, and Counter Mode. In Timer Mode, the input clock for a timer is derived from the CPU clock, divided by a programmable prescaler. Counter Mode allows a timer to be clocked in reference to external events. Pulse width or duty cycle measurement is supported in Gated Timer Mode where the operation of a timer is controlled by the 'gate' level on an external input pin. Each timer has one associated port pin (TxIN) which serves as gate or clock input. The maximum resolution of the timers in module GPT1 is 400ns (@ 20MHz CPU clock).

The count direction (up/down) for each timer is programmable by software or may be altered dynamically by an external signal on a port pin (TxEUD) to facilitate, for example, position tracking.

Timers T3 and T4 have output toggle latches (TxOTL) which change their state on each timer overflow/underflow. The state of these latches may be output on port pins (TxOUT) for time-out monitoring by external hardware components, or may be used internally to clock timers T2 and T4 for measuring long time periods with high resolution.

In addition to their basic operating modes, timers T2 and T4 may be configured as reload or capture

registers for timer T3. When used as capture or reload registers, timers T2 and T4 are stopped. The contents of timer T3 are captured into T2 or T4 in response to a signal at their associated input pins (TxIN). Timer T3 is reloaded with the contents of T2 or T4, triggered, either by an external signal, or by a selectable state transition of its toggle latch T3OTL. When both T2 and T4 are configured to alternately reload T3 on opposite state transitions of T3OTL with the low and high times of a PWM signal, this signal can be constantly generated without software intervention.

With its maximum resolution of 160 ns (@ 20MHz), the GPT2 module provides precise event control and time measurement. It includes two timers (T5, T6) and a capture/reload register (CAPREL). Both timers can be clocked with an input clock which is derived from the CPU clock via a programmable prescaler or with external signals. The count direction (up/down) for each timer is programmable by software or may additionally be altered dynamically by an external signal on a port pin (TxEUD). Concatenation of the timers is supported via the output toggle latch (T6OTL) of timer T6, which changes its state on each timer overflow/underflow.

The state of this latch may be used to clock timer T5, or it may be output on a port pin (T6OUT). The overflows/underflows of timer T6 can additionally be used to clock the CAPCOM timers T0 or T1, and to cause a reload from the CAPREL register. The CAPREL register may capture the contents of timer T5 based on an external signal transition on the corresponding port pin (CAPIN), and timer T5 may optionally be cleared after the capture procedure. This allows absolute time differences to be measured or pulse multiplication to be performed without software overhead.

Figure 10.1 Block Diagram of GPT1

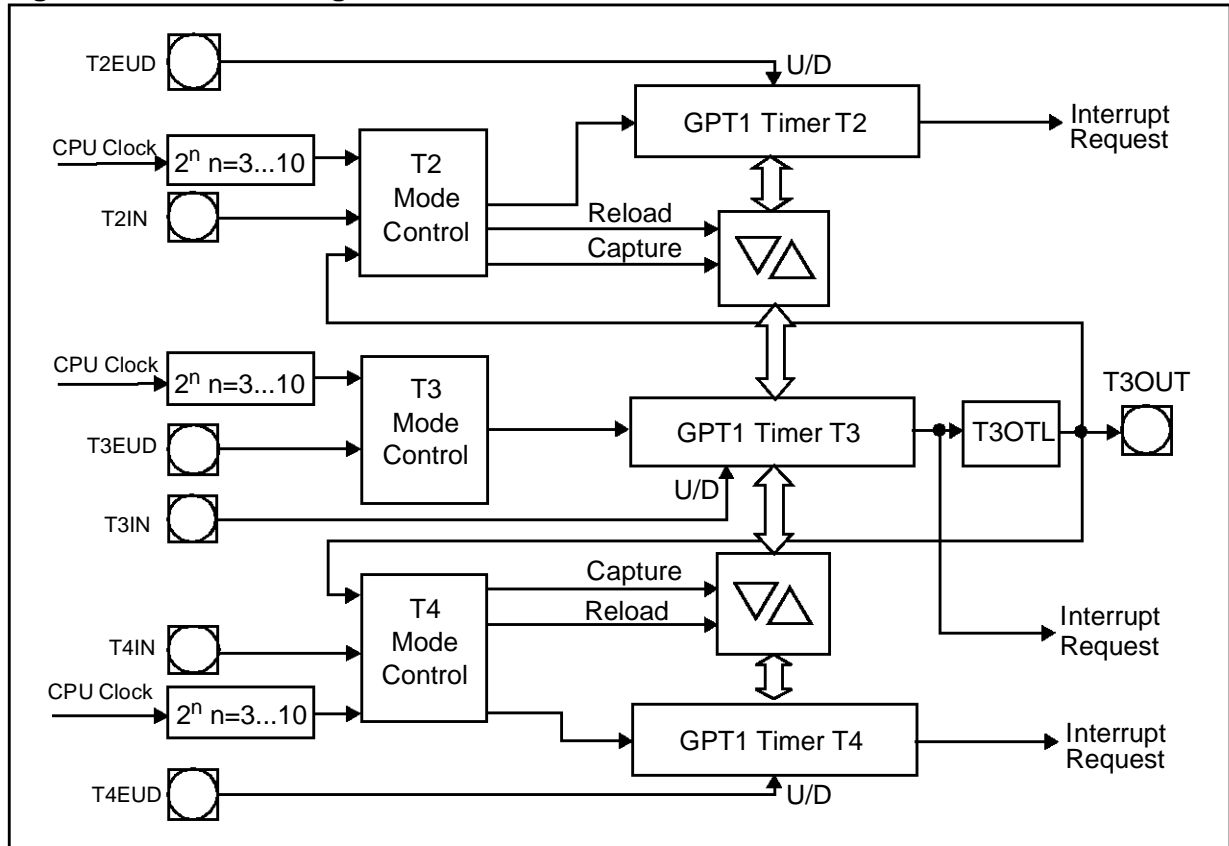
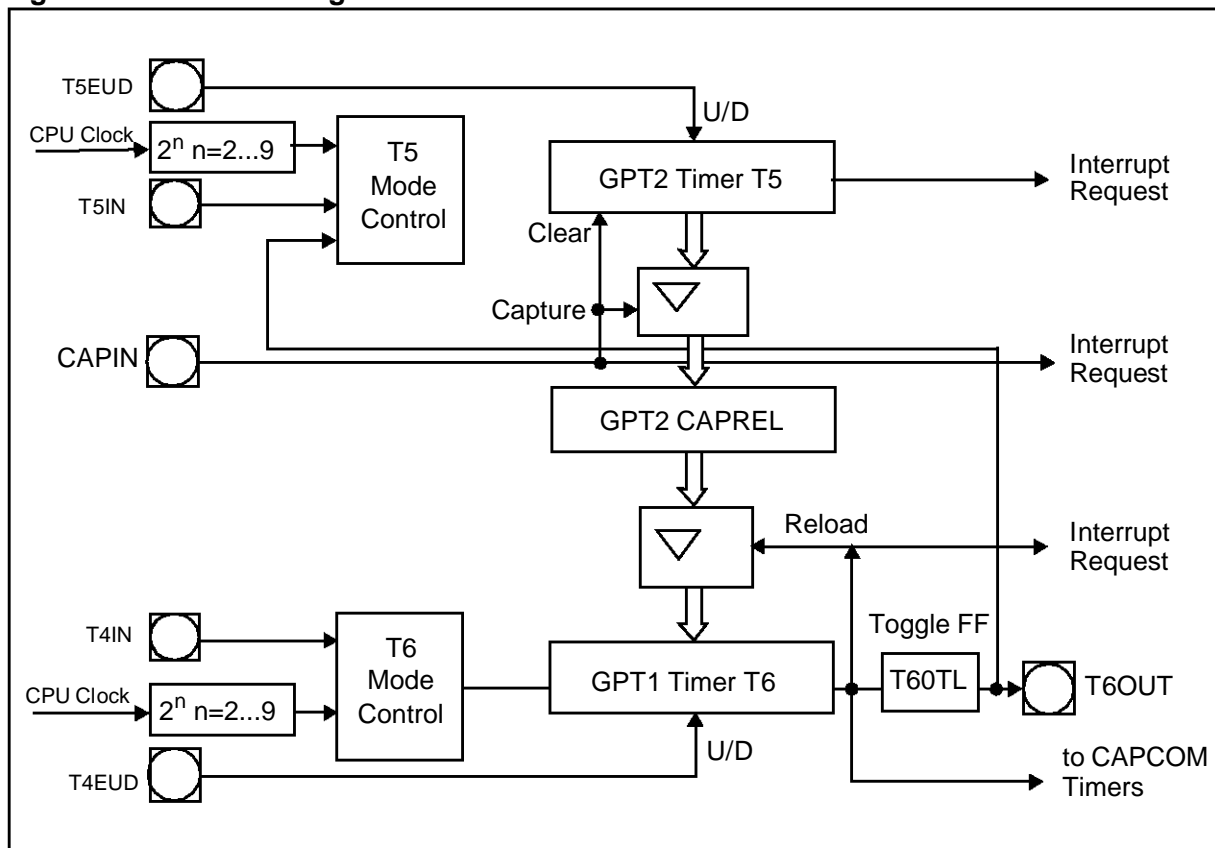

Figure 10.2 Block Diagram of GPT2



11 PWM MODULE

The Pulse Width Modulation Module can generate up to four PWM output signals using edge-aligned or centre-aligned PWM. In addition the PWM module can generate PWM burst signals and single shot outputs. The frequency range of the PWM

signals is from 4.8 Hz to 1 MHz (referred to a CPU clock of 20 MHz), depending on the resolution of the PWM output signal. The level of the output signals is selectable and the PWM module can generate interrupt requests.

12 WATCHDOG TIMER

The Watchdog Timer is a fail-safe mechanism. It limits the maximum malfunction time of the controller

The Watchdog Timer is always enabled after a reset of the chip, and can only be disabled in the time interval until the EINIT (end of initialization) instruction has been executed. In this way the chip's start-up procedure is always monitored. The software must be designed to service the Watchdog Timer before it overflows. If, due to hardware or software related failures, the software fails to do so, the Watchdog Timer overflows and generates an internal hardware reset and pulls the $\overline{\text{RSTOUT}}$

pin low in order to allow external hardware components to be reset.

The Watchdog Timer is a 16-bit timer, clocked with the system clock divided either by 2 or by 128. The high byte of the Watchdog Timer register can be set to a pre-specified reload value (stored in WDTREL) in order to allow further variation of the monitored time interval. Each time it is serviced by the application software, the high byte of the Watchdog Timer is reloaded. Therefore, time intervals between 25 μ s and 420ms can be monitored (@ 20 MHz). The default Watchdog Timer interval after reset is 6.55 ms (@ 20 MHz).

13 A/D CONVERTER

A 10-bit A/D converter with 16 multiplexed input channels and a sample and hold circuit has been integrated on-chip for analog signal measurement. It uses a successive approximation method. The sample time (for loading the capacitors) and conversion time is programmable and can be modified for the external circuitry.

Overflow error detection/protection is provided for the conversion result register (ADDAT). When the result of a previous conversion has not been read from the result register at the time the next conversion is complete, either an interrupt request is generated, or the next conversion is suspended, until the previous result has been read.

For applications which require less than 16 analog input channels, the remaining channel inputs can be used as digital input port pins.

The A/D converter of the ST10F167 supports four different conversion modes. In the standard Single Channel conversion mode, the analog level on a specified channel is sampled once and converted to a digital result. In the Single Channel Continuous mode, the analog level on a specified channel is repeatedly sampled and converted without soft-

ware intervention. In the Auto Scan mode, the analog levels on a prespecified number of channels are sequentially sampled and converted. In the Auto Scan Continuous mode, the number of prespecified channels is repeatedly sampled and converted. In addition, the conversion of a specific channel can be inserted (injected) into a running sequence without disturbing this sequence. This is called Channel Injection Mode.

The Peripheral Event Controller (PEC) may be used to automatically store the conversion results into a table in memory for later evaluation, without the overhead of interrupt routines for each data transfer.

After each reset and also during normal operation, the ADC automatically performs calibration cycles. This automatic self-calibration constantly adjusts the converter to the changing operating conditions (e.g. temperature) and compensates process variations.

These calibration cycles are part of the conversion cycle. They do not affect the normal operation of the A/D converter.

14 SERIAL CHANNELS

Serial communication with other microcontrollers, processors, terminals or external peripheral components is provided by two serial interfaces. An Asynchronous/Synchronous Serial Channel (ASC0) and a High-Speed Synchronous Serial Channel (SSC).

ASC0 supports full-duplex asynchronous communication up to 625 Kbaud and half-duplex synchronous communication up to 2.5 Mbaud @ 20MHz system clock.

The SSC allows half duplex synchronous communication up to 5 Mbaud @ 20MHz system clock.

Two dedicated baud rate generators are used to set up standard baud rates without oscillator tuning. For transmission, reception, and erroneous reception, 3 separate interrupt vectors are provided for each serial channel.

In asynchronous mode, 8- or 9-bit data frames are transmitted or received, preceded by a start bit and terminated by one or two stop bits. For multi-processor communication, a mechanism to distin-

guish address from data bytes has been included (8-bit data + wake up bit mode).

In synchronous mode, the ASC0 transmits or receives bytes (8 bits) synchronously to a shift clock which is generated by the ASC0. The SSC transmits or receives characters of 2...16 bits length synchronously to a shift clock. The shift clock can be generated by the SSC (master mode) or by an external master (slave mode). The SSC can start shifting with the LSB or with the MSB, while the ASC0 always shifts the LSB first. A loop back option is available for testing purposes.

A number of optional hardware error detection capabilities have been included to increase the reliability of data transfers. A parity bit can automatically be generated on transmission or be checked on reception. 'framing error detection' recognizes data frames with missing stop bits. An overrun error is generated if the last character received was not read out of the receive buffer register, on the reception of a new character.

15 CAN-MODULE

The integrated CAN-Module performs the autonomous transmission and reception of CAN frames in accordance with the CAN specification V2.0 part B (active). The on-chip CAN-Module can receive and transmit standard frames with 11-bit identifiers as well as extended frames with 29-bit identifiers.

The module provides full CAN functionality for up to 15 message objects. Message object 15 may be configured for Basic CAN functionality. Both modes provide separate masks for acceptance fil-

tering which allows to accept a number of identifiers in Full CAN mode and also allows to disregard a number of identifiers in Basic CAN mode. All message objects can be updated independent from the other objects and are equipped for the maximum message length of 8 bytes.

The bit timing is derived from the XCLK and is programmable up to a data rate of 1 Mbaud. The CAN-Module uses two pins to interface to a bus transceiver.

16 PARALLEL PORTS

The ST10F167 provides up to 77 I/O lines which are organized into eight input/output ports and one input port. All port lines are bit-addressable, and all input/output lines are individually (bit-wise) programmable as inputs or outputs via direction registers. The I/O ports are true bidirectional ports which are switched to high impedance state when configured as inputs. The output drivers of three I/O ports can be configured (pin by pin) for push/pull operation or open-drain operation via control registers. During the internal reset, all port pins are configured as inputs.

The input threshold of Port 2, Port 3, Port 7 and Port 8 is selectable (TTL or CMOS like). The special CMOS like input threshold reduces noise sensitivity due to the input hysteresis. The input threshold may be selected individually for each byte of the respective ports.

All port lines have programmable alternate input or output functions associated with them. PORT0 and PORT1 may be used as address and data lines when accessing external memory, while Port 4 outputs the additional segment address bits A23/19/17...A16 in systems where segmentation is enabled to access more than 64KBytes of memory. Port 2, Port 8 and Port 7 are associated with the capture inputs or compare outputs of the CAP-COM units and/or with the outputs of the PWM module. Port 6 provides optional bus arbitration signals ($\overline{\text{BREQ}}$, $\overline{\text{HLD A}}$, $\overline{\text{HOLD}}$) and chip select signals. Port 3 includes alternate functions of timers, serial interfaces, the optional bus control signal $\overline{\text{BHE}}$ and the system clock output (CLKOUT). Port 5 is used for the analog input channels to the A/D converter or timer control signals.

All port lines that are not used for these alternate functions may be used as general purpose IO lines.

17 INSTRUCTION SET SUMMARY

The table below lists the instruction set of the ST10F167. More detailed information such as address modes, instruction operation, parameters for

conditional execution of instructions, opcodes and a detailed description of each instruction can be found in the “ST10 Programming Manual”..

Table 17.1 Instruction Set

Mnemonic	Description	Bytes
ADD(B)	Add word (byte) operands	2 / 4
ADDC(B)	Add word (byte) operands with Carry	2 / 4
SUB(B)	Subtract word (byte) operands	2 / 4
SUBC(B)	Subtract word (byte) operands with Carry	2 / 4
MUL(U)	(Un)Signed multiply direct GPR by direct GPR (16-16-bit)	2
DIV(U)	(Un)Signed divide register MDL by direct GPR (16-/16-bit)	2
DIVL(U)	(Un)Signed long divide reg. MD by direct GPR (32-/16-bit)	2
CPL(B)	Complement direct word (byte) GPR	2
NEG(B)	Negate direct word (byte) GPR	2
AND(B)	Bitwise AND, (word/byte operands)	2 / 4
OR(B)	Bitwise OR, (word/byte operands)	2 / 4
XOR(B)	Bitwise XOR, (word/byte operands)	2 / 4
BCLR	Clear direct bit	2
BSET	Set direct bit	2
BMOV(N)	Move (negated) direct bit to direct bit	4
BAND, BOR, BXOR	AND/OR/XOR direct bit with direct bit	4
BCMP	Compare direct bit to direct bit	4
BFLDH/L	Bitwise modify masked high/low byte of bit-addressable direct word memory with immediate data	4
CMP(B)	Compare word (byte) operands	2 / 4
CMPD1/2	Compare word data to GPR and decrement GPR by 1/2	2 / 4
CMPI1/2	Compare word data to GPR and increment GPR by 1/2	2 / 4
PRIOR	Determine number of shift cycles to normalize direct word GPR and store result in direct word GPR	2
SHL / SHR	Shift left/right direct word GPR	2
ROL / ROR	Rotate left/right direct word GPR	2
ASHR	Arithmetic (sign bit) shift right direct word GPR	2
MOV(B)	Move word (byte) data	2 / 4
MOVBS	Move byte operand to word operand with sign extension	2 / 4
MOVBZ	Move byte operand to word operand. with zero extension	2 / 4
JMPA, JMPI, JMPR	Jump absolute/indirect/relative if condition is met	4
JMPS	Jump absolute to a code segment	4
J(N)B	Jump relative if direct bit is (not) set	4

Table 17.1 Instruction Set (cont'd)

Mnemonic	Description	Bytes
JBC	Jump relative and clear bit if direct bit is set	4
JNBS	Jump relative and set bit if direct bit is not set	4
CALLA, CALLI, CALLR	Call absolute/indirect/relative subroutine if condition is met	4
CALLS	Call absolute subroutine in any code segment	4
PCALL	Push direct word register onto system stack and call absolute subroutine	4
TRAP	Call interrupt service routine via immediate trap number	2
PUSH, POP	Push/pop direct word register onto/from system stack	2
SCXT	Push direct word register onto system stack and update register with word operand	4
RET	Return from intra-segment subroutine	2
RETS	Return from inter-segment subroutine	2
RETP	Return from intra-segment subroutine and pop direct word register from system stack	2
RETI	Return from interrupt service subroutine	2
SRST	Software Reset	4
IDLE	Enter Idle Mode	4
PWRDN	Enter Power Down Mode (assumes $\overline{\text{NMI}}$ -pin low)	4
SRVWDT	Service Watchdog Timer	4
DISWDT	Disable Watchdog Timer	4
EINIT	Signify End-of-Initialization on RSTOUT-pin	4
ATOMIC	Begin ATOMIC sequence	2
EXTR	Begin EXTENDED Register sequence	2
EXTP(R)	Begin EXTENDED Page (and Register) sequence	2 / 4
EXTS(R)	Begin EXTENDED Segment (and Register) sequence	2 / 4
NOP	Null operation	2

18 BOOTSTRAP LOADER

To activate the Boot-strap loader, a hardware reset with $\overline{\text{RSTIN}}$ pin low and an external pull-up resistor connected to the ALE pin, is applied. This forces the chip into a special test mode. The program execution starts from 1K bytes ROM, mapped from 0 to 3FF hex which is not accessible in normal execution mode.

This test ROM contains a one-time programmable flash EPROM, loaded with a self-test program plus the Boot-strap loader program. When the Boot-

strap loader mode is activated, an instruction fetch is performed from the test ROM regardless of the configuration selected with the EBC0, EBC1 and $\overline{\text{BUSACT}}$ pins. The reset vector in the test ROM branches to the self-test program, while the Non-Maskable Interrupt vector ($\overline{\text{NMI}}$) branches to the Boot-strap loader routine.

The self-test routine execution time is approximately 10ms. It terminates with a software reset instruction (SRST), where the chip is restarted ac-

ording to the EBC0, EBC1 and $\overline{\text{BUSACT}}$ pin configurations. The state of the ALE pin is not taken into account for software reset. To trigger the Boot-strap loader program, it is necessary to activate the Non Maskable Interrupt by forcing a low level on the $\overline{\text{NMI}}$ pin before the end of the self-test routine

The identification byte sent by the ST10F167 is D5h. Note that the bootstrap loader of all ST10 devices which include identification registers will return D5h as the identification byte. The startup code loaded with bootstrap loader will dump identification registers for complete chip identification from the host.

19 SPECIAL FUNCTION REGISTER OVERVIEW

The following table lists all ST10F167 SFRs in alphabetical order.

Bit-addressable SFRs are marked with the letter “b” in column “Name”. SFRs within the **Extended SFR-Space** (ESFRs) are marked with the letter “E” in column “Physical Address”.

An SFR can be specified via its individual mnemonic name. Depending on the selected addressing mode, an SFR can be accessed via its physical address (using the Data Page Pointers), or via its short 8-bit address (without using the Data Page Pointers).

Table 19.1 Special Function Register List

Name	Physical Address	8-Bit Address	Description	Reset Value
ADCIC b	FF98h	CCh	A/D Converter End of Conversion Interrupt Cont Reg	0000h
ADCON b	FFA0h	D0h	A/D Converter Control Register	0000h
ADDAT	FEA0h	50h	A/D Converter Result Register	0000h
ADDAT2	F0A0h E	50h	A/D Converter 2 Result Register	0000h
ADDRSEL1	FE18h	0Ch	Address Select Register 1	0000h
ADDRSEL2	FE1Ah	0Dh	Address Select Register 2	0000h
ADDRSEL3	FE1Ch	0Eh	Address Select Register 3	0000h
ADDRSEL4	FE1Eh	0Fh	Address Select Register 4	0000h
ADEIC b	FF9Ah	CDh	A/D Converter Overrun Error Interrupt Control Reg	0000h
BUSCON0 b	FF0Ch	86h	Bus Configuration Register 0	0XX0h
BUSCON1 b	FF14h	8Ah	Bus Configuration Register 1	0000h
BUSCON2 b	FF16h	8Bh	Bus Configuration Register 2	0000h
BUSCON3 b	FF18h	8Ch	Bus Configuration Register 3	0000h
BUSCON4 b	FF1Ah	8Dh	Bus Configuration Register 4	0000h
CAPREL	FE4Ah	25h	GPT2 Capture/Reload Register	0000h
CC0	FE80h	40h	CAPCOM Register 0	0000h
CC0IC b	FF78h	BCh	CAPCOM Register 0 Interrupt Control Register	0000h
CC1	FE82h	41h	CAPCOM Register 1	0000h
CC1IC b	FF7Ah	BDh	CAPCOM Register 1 Interrupt Control Register	0000h
CC2	FE84h	42h	CAPCOM Register 2	0000h
CC2IC b	FF7Ch	BEh	CAPCOM Register 2 Interrupt Control Register	0000h

Table 19.1 Special Function Register List (cont'd)

Name	Physical Address	8-Bit Address	Description	Reset Value
CC3	FE86h	43h	CAPCOM Register 3	0000h
CC3IC b	FF7Eh	BFh	CAPCOM Register 3 Interrupt Control Register	0000h
CC4	FE88h	44h	CAPCOM Register 4	0000h
CC4IC b	FF80h	C0h	CAPCOM Register 4 Interrupt Control Register	0000h
CC5	FE8Ah	45h	CAPCOM Register 5	0000h
CC5IC b	FF82h	C1h	CAPCOM Register 5 Interrupt Control Register	0000h
CC6	FE8Ch	46h	CAPCOM Register 6	0000h
CC6IC b	FF84h	C2h	CAPCOM Register 6 Interrupt Control Register	0000h
CC7	FE8Eh	47h	CAPCOM Register 7	0000h
CC7IC b	FF86h	C3h	CAPCOM Register 7 Interrupt Control Register	0000h
CC8	FE90h	48h	CAPCOM Register 8	0000h
CC8IC b	FF88h	C4h	CAPCOM Register 8 Interrupt Control Register	0000h
CC9	FE92h	49h	CAPCOM Register 9	0000h
CC9IC b	FF8Ah	C5h	CAPCOM Register 9 Interrupt Control Register	0000h
CC10	FE94h	4Ah	CAPCOM Register 10	0000h
CC10IC b	FF8Ch	C6h	CAPCOM Register 10 Interrupt Control Register	0000h
CC11	FE96h	4Bh	CAPCOM Register 11	0000h
CC11IC b	FF8Eh	C7h	CAPCOM Register 11 Interrupt Control Register	0000h
CC12	FE98h	4Ch	CAPCOM Register 12	0000h
CC12IC b	FF90h	C8h	CAPCOM Register 12 Interrupt Control Register	0000h
CC13	FE9Ah	4Dh	CAPCOM Register 13	0000h
CC13IC b	FF92h	C9h	CAPCOM Register 13 Interrupt Control Register	0000h
CC14	FE9Ch	4Eh	CAPCOM Register 14	0000h
CC14IC b	FF94h	CAh	CAPCOM Register 14 Interrupt Control Register	0000h
CC15	FE9Eh	4Fh	CAPCOM Register 15	0000h
CC15IC b	FF96h	CBh	CAPCOM Register 15 Interrupt Control Register	0000h
CC16	FE60h	30h	CAPCOM Register 16	0000h
CC16IC b	F160h E	B0h	CAPCOM Register 16 Interrupt Control Register	0000h
CC17	FE62h	31h	CAPCOM Register 17	0000h
CC17IC b	F162h E	B1h	CAPCOM Register 17 Interrupt Control Register	0000h
CC18	FE64h	32h	CAPCOM Register 18	0000h
CC18IC b	F164h E	B2h	CAPCOM Register 18 Interrupt Control Register	0000h
CC19	FE66h	33h	CAPCOM Register 19	0000h
CC19IC b	F166h E	B3h	CAPCOM Register 19 Interrupt Control Register	0000h
CC20	FE68h	34h	CAPCOM Register 20	0000h
CC20IC b	F168h E	B4h	CAPCOM Register 20 Interrupt Control Register	0000h

Table 19.1 Special Function Register List (cont'd)

Name	Physical Address	8-Bit Address	Description	Reset Value
CC21	FE6Ah	35h	CAPCOM Register 21	0000h
CC21IC b	F16Ah E	B5h	CAPCOM Register 21 Interrupt Control Register	0000h
CC22	FE6Ch	36h	CAPCOM Register 22	0000h
CC22IC b	F16Ch E	B6h	CAPCOM Register 22 Interrupt Control Register	0000h
CC23	FE6Eh	37h	CAPCOM Register 23	0000h
CC23IC b	F16Eh E	B7h	CAPCOM Register 23 Interrupt Control Register	0000h
CC24	FE70h	38h	CAPCOM Register 24	0000h
CC24IC b	F170h E	B8h	CAPCOM Register 24 Interrupt Control Register	0000h
CC25	FE72h	39h	CAPCOM Register 25	0000h
CC25IC b	F172h E	B9h	CAPCOM Register 25 Interrupt Control Register	0000h
CC26	FE74h	3Ah	CAPCOM Register 26	0000h
CC26IC b	F174h E	BAh	CAPCOM Register 26 Interrupt Control Register	0000h
CC27	FE76h	3Bh	CAPCOM Register 27	0000h
CC27IC b	F176h E	BBh	CAPCOM Register 27 Interrupt Control Register	0000h
CC28	FE78h	3Ch	CAPCOM Register 28	0000h
CC28IC b	F178h E	BCh	CAPCOM Register 28 Interrupt Control Register	0000h
CC29	FE7Ah	3Dh	CAPCOM Register 29	0000h
CC29IC b	F184h E	C2h	CAPCOM Register 29 Interrupt Control Register	0000h
CC30	FE7Ch	3Eh	CAPCOM Register 30	0000h
CC30IC b	F18Ch E	C6h	CAPCOM Register 30 Interrupt Control Register	0000h
CC31	FE7Eh	3Fh	CAPCOM Register 31	0000h
CC31IC b	F194h E	CAh	CAPCOM Register 31 Interrupt Control Register	0000h
CCM0 b	FF52h	A9h	CAPCOM Mode Control Register 0	0000h
CCM1 b	FF54h	AAh	CAPCOM Mode Control Register 1	0000h
CCM2 b	FF56h	ABh	CAPCOM Mode Control Register 2	0000h
CCM3 b	FF58h	ACH	CAPCOM Mode Control Register 3	0000h
CCM4 b	FF22h	91h	CAPCOM Mode Control Register 4	0000h
CCM5 b	FF24h	92h	CAPCOM Mode Control Register 5	0000h
CCM6 b	FF26h	93h	CAPCOM Mode Control Register 6	0000h
CCM7 b	FF28h	94h	CAPCOM Mode Control Register 7	0000h
CP	FE10h	08h	CPU Context Pointer Register	FC00h
CRIC b	FF6Ah	B5h	GPT2 CAPREL Interrupt Control Register	0000h
CSP	FE08h	04h	CPU Code Segment Pointer Register (read only)	0000h
DP0L b	F100h E	80h	P0L Direction Control Register	00h
DP0H b	F102h E	81h	P0H Direction Control Register	00h
DP1L b	F104h E	82h	P1L Direction Control Register	00h

Table 19.1 Special Function Register List (cont'd)

Name	Physical Address	8-Bit Address	Description	Reset Value
DP1H	b F106h E	83h	P1H Direction Control Register	00h
DP2	b FFC2h	E1h	Port 2 Direction Control Register	0000h
DP3	b FFC6h	E3h	Port 3 Direction Control Register	0000h
DP4	b FFCAh	E5h	Port 4 Direction Control Register	00h
DP6	b FFCEh	E7h	Port 6 Direction Control Register	00h
DP7	b FFD2h	E9h	Port 7 Direction Control Register	00h
DP8	b FFD6h	EBh	Port 8 Direction Control Register	00h
DPP0	FE00h	00h	CPU Data Page Pointer 0 Register (10 bits)	0000h
DPP1	FE02h	01h	CPU Data Page Pointer 1 Register (10 bits)	0001h
DPP2	FE04h	02h	CPU Data Page Pointer 2 Register (10 bits)	0002h
DPP3	FE06h	03h	CPU Data Page Pointer 3 Register (10 bits)	0003h
EXICON	b F1C0h E	E0h	External Interrupt Control Register	0000h
MDC	b FF0Eh	87h	CPU Multiply Divide Control Register	0000h
MDH	FE0Ch	06h	CPU Multiply Divide Register – High Word	0000h
MDL	FE0Eh	07h	CPU Multiply Divide Register – Low Word	0000h
ODP2	b F1C2h E	E1h	Port 2 Open Drain Control Register	0000h
ODP3	b F1C6h E	E3h	Port 3 Open Drain Control Register	0000h
ODP6	b F1CEh E	E7h	Port 6 Open Drain Control Register	00h
ODP7	b F1D2h E	E9h	Port 7 Open Drain Control Register	00h
ODP8	b F1D6h E	EBh	Port 8 Open Drain Control Register	00h
ONES	FF1Eh	8Fh	Constant Value 1's Register (read only)	FFFFh
P0L	b FF00h	80h	Port 0 Low Register (Lower half of PORT0)	00h
P0H	b FF02h	81h	Port 0 High Register (Upper half of PORT0)	00h
P1L	b FF04h	82h	Port 1 Low Register (Lower half of PORT1)	00h
P1H	b FF06h	83h	Port 1 High Register (Upper half of PORT1)	00h
P2	b FFC0h	E0h	Port 2 Register	0000h
P3	b FFC4h	E2h	Port 3 Register	0000h
P4	b FFC8h	E4h	Port 4 Register (8 bits)	00h
P5	b FFA2h	D1h	Port 5 Register (read only)	XXXXh
P6	b FFCh	E6h	Port 6 Register (8 bits)	00h
P7	b FFD0h	E8h	Port 7 Register (8 bits)	00h
P8	b FFD4h	EAh	Port 8 Register (8 bits)	00h
PECC0	FEC0h	60h	PEC Channel 0 Control Register	0000h
PECC1	FEC2h	61h	PEC Channel 1 Control Register	0000h
PECC2	FEC4h	62h	PEC Channel 2 Control Register	0000h
PECC3	FEC6h	63h	PEC Channel 3 Control Register	0000h

Table 19.1 Special Function Register List (cont'd)

Name	Physical Address	8-Bit Address	Description	Reset Value
PECC4	FEC8h	64h	PEC Channel 4 Control Register	0000h
PECC5	FECAh	65h	PEC Channel 5 Control Register	0000h
PECC6	FECCh	66h	PEC Channel 6 Control Register	0000h
PECC7	FECEh	67h	PEC Channel 7 Control Register	0000h
PICON	F1C4h E	E2h	Port Input Threshold Control Register	0000h
PP0	F038h E	1Ch	PWM Module Period Register 0	0000h
PP1	F03Ah E	1Dh	PWM Module Period Register 1	0000h
PP2	F03Ch E	1Eh	PWM Module Period Register 2	0000h
PP3	F03Eh E	1Fh	PWM Module Period Register 3	0000h
PSW b	FF10h	88h	CPU Program Status Word	0000h
PT0	F030h E	18h	PWM Module Up/Down Counter 0	0000h
PT1	F032h E	19h	PWM Module Up/Down Counter 1	0000h
PT2	F034h E	1Ah	PWM Module Up/Down Counter 2	0000h
PT3	F036h E	1Bh	PWM Module Up/Down Counter 3	0000h
PW0	FE30h	18h	PWM Module Pulse Width Register 0	0000h
PW1	FE32h	19h	PWM Module Pulse Width Register 1	0000h
PW2	FE34h	1Ah	PWM Module Pulse Width Register 2	0000h
PW3	FE36h	1Bh	PWM Module Pulse Width Register 3	0000h
PWMCON0b	FF30h	98h	PWM Module Control Register 0	0000h
PWMCON1b	FF32h	99h	PWM Module Control Register 1	0000h
PWMIC b	F17Eh E	BFh	PWM Module Interrupt Control Register	0000h
RP0H b	F108h E	84h	System Startup Configuration Register (Rd. only)	XXh
S0BG	FEB4h	5Ah	Serial Channel 0 Baud Rate Generator Reload Reg	0000h
S0CON b	FFB0h	D8h	Serial Channel 0 Control Register	0000h
S0EIC b	FF70h	B8h	Serial Channel 0 Error Interrupt Control Register	0000h
S0RBUF	FEB2h	59h	Serial Channel 0 Receive Buffer Register (read only)	XXh
S0RIC b	FF6Eh	B7h	Serial Channel 0 Receive Interrupt Control Register	0000h
S0TBIC b	F19Ch E	CEh	Serial Channel 0 Transmit Buffer Interrupt Control Register	0000h
S0TBUF	FEB0h	58h	Serial Channel 0 Transmit Buffer Register (write only)	00h
S0TIC b	FF6Ch	B6h	Serial Channel 0 Transmit Interrupt Control Register	0000h
SP	FE12h	09h	CPU System Stack Pointer Register	FC00h
SSCBR	F0B4h E	5Ah	SSC Baudrate Register	0000h
SSCCON b	FFB2h	D9h	SSC Control Register	0000h
SSCEIC b	FF76h	BBh	SSC Error Interrupt Control Register	0000h
SSCRB	F0B2h E	59h	SSC Receive Buffer (read only)	XXXXh

Table 19.1 Special Function Register List (cont'd)

Name	Physical Address	8-Bit Address	Description	Reset Value
SSCRIC	b FF74h	BAh	SSC Receive Interrupt Control Register	0000h
SSCTB	F0B0h E	58h	SSC Transmit Buffer (write only)	0000h
SSCTIC	b FF72h	B9h	SSC Transmit Interrupt Control Register	0000h
STKOV	FE14h	0Ah	CPU Stack Overflow Pointer Register	FA00h
STKUN	FE16h	0Bh	CPU Stack Underflow Pointer Register	FC00h
SYSCON	b FF12h	89h	CPU System Configuration Register	0xx0h ¹⁾
T0	FE50h	28h	CAPCOM Timer 0 Register	0000h
T01CON	b FF50h	A8h	CAPCOM Timer 0 and Timer 1 Control Register	0000h
T0IC	b FF9Ch	CEh	CAPCOM Timer 0 Interrupt Control Register	0000h
T0REL	FE54h	2Ah	CAPCOM Timer 0 Reload Register	0000h
T1	FE52h	29h	CAPCOM Timer 1 Register	0000h
T1IC	b FF9Eh	CFh	CAPCOM Timer 1 Interrupt Control Register	0000h
T1REL	FE56h	2Bh	CAPCOM Timer 1 Reload Register	0000h
T2	FE40h	20h	GPT1 Timer 2 Register	0000h
T2CON	b FF40h	A0h	GPT1 Timer 2 Control Register	0000h
T2IC	b FF60h	B0h	GPT1 Timer 2 Interrupt Control Register	0000h
T3	FE42h	21h	GPT1 Timer 3 Register	0000h
T3CON	b FF42h	A1h	GPT1 Timer 3 Control Register	0000h
T3IC	b FF62h	B1h	GPT1 Timer 3 Interrupt Control Register	0000h
T4	FE44h	22h	GPT1 Timer 4 Register	0000h
T4CON	b FF44h	A2h	GPT1 Timer 4 Control Register	0000h
T4IC	b FF64h	B2h	GPT1 Timer 4 Interrupt Control Register	0000h
T5	FE46h	23h	GPT2 Timer 5 Register	0000h
T5CON	b FF46h	A3h	GPT2 Timer 5 Control Register	0000h
T5IC	b FF66h	B3h	GPT2 Timer 5 Interrupt Control Register	0000h
T6	FE48h	24h	GPT2 Timer 6 Register	0000h
T6CON	b FF48h	A4h	GPT2 Timer 6 Control Register	0000h
T6IC	b FF68h	B4h	GPT2 Timer 6 Interrupt Control Register	0000h
T7	F050h E	28h	CAPCOM Timer 7 Register	0000h
T78CON	b FF20h	90h	CAPCOM Timer 7 and 8 Control Register	0000h
T7IC	b F17Ah E	BEh	CAPCOM Timer 7 Interrupt Control Register	0000h
T7REL	F054h E	2Ah	CAPCOM Timer 7 Reload Register	0000h
T8	F052h E	29h	CAPCOM Timer 8 Register	0000h
T8IC	b F17Ch E	BFh	CAPCOM Timer 8 Interrupt Control Register	0000h
T8REL	F056h E	2Bh	CAPCOM Timer 8 Reload Register	0000h
TFR	b FFACCh	D6h	Trap Flag Register	0000h

Table 19.1 Special Function Register List (cont'd)

Name	Physical Address	8-Bit Address	Description	Reset Value
WDT	FEAEh	57h	Watchdog Timer Register (read only)	0000h
WDTCON	FFAEh	D7h	Watchdog Timer Control Register	000Xh ²⁾
XP0IC b	F186h E	C3h	CAN Module Interrupt Control Register	0000h
XP1IC b	F18Eh E	C7h	X-Peripheral 1 Interrupt Control Register	0000h
XP2IC b	F196h E	CBh	X-Peripheral 2 Interrupt Control Register	0000h
XP3IC b	F19Eh E	CFh	PLL Interrupt Control Register	0000h
ZEROS b	FF1Ch	8Eh	Constant Value 0's Register (read only)	0000h

Notes 1: The system configuration is selected during reset.

2: Bit WDTR indicates a watchdog timer triggered reset.

3: The Interrupt Control Registers XPnIC, control interrupt requests from integrated X-Bus peripherals. Nodes, where no X-Peripherals are connected, may be used to generate software controlled interrupt requests by setting the respective XPnIR bit.

20 ELECTRICAL CHARACTERISTICS

20.1 Absolute Maximum Ratings

Ambient temperature under bias (T_A): ST10F167.....	-40 to +85 °C
Storage temperature (T_{ST}).....	-65 to +150 °C
Voltage on V_{DD} pins with respect to ground (V_{SS}).....	-0.5 to +6.5 V
Voltage on any pin with respect to ground (V_{SS}).....	-0.3 to V_{DD} +0.3 V
Input current on any pin during overload condition.....	-10 to +10 mA
Absolute sum of all input currents during overload condition.....	100 mA
Power dissipation.....	1.5 W

Note: Stresses above those listed under “Absolute Maximum Ratings” may cause permanent damage to the device. This is a stress rating only and functional operation of the device at these or any other conditions above those indicated in the operational sections of this specification is not guaranteed. Exposure to absolute maximum rating conditions for extended periods may affect device reliability. During overload conditions ($V_{IN} > V_{DD}$ or $V_{IN} < V_{SS}$) the voltage on pins with respect to ground (V_{SS}) must not exceed the values defined by the Absolute Maximum Ratings.

20.2 Parameter Interpretation

The parameters listed in the Electrical Characteristics tables, 20.1 to 20.9, represent the characteristics of the ST10F167 and its demands on the system.

Where the ST10F167 logic provides signals with their respective timing characteristics, the symbol

“CC” for Controller Characteristics, is included in the “Symbol” column.

Where the external system must provide signals with their respective timing characteristics to the ST10F167, the symbol “SR” for System Requirement, is included in the “Symbol” column.

20.3 DC Characteristics

$V_{DD} = 5\text{ V} \pm 5\%$, $V_{SS} = 0$, $f_{CPU} = 20\text{MHz}$, Reset active, $T_A = -40$ to $+85\text{ }^\circ\text{C}$

Table 20.1 DC Parametric

Parameter	Symbol	Limit Values		Unit	Test Condition
		min.	max.		
Input low voltage (TTL)	V_{ILSR}	-0.5	$0.2 V_{DD}$ -0.1	V	-
Input low voltage (Special Threshold)	$V_{ILS}SR$	-0.5	2.0	V	-
Input high voltage, all except \overline{RSTIN} and XTAL1 (TTL)	V_{IHSR}	$0.2 V_{DD}$ +0.9	$V_{DD} + 0.5$	V	-
Input high voltage \overline{RSTIN}	$V_{IH1}SR$	$0.6 V_{DD}$	$V_{DD} + 0.5$	V	-
Input high voltage XTAL1	$V_{IH2}SR$	$0.7 V_{DD}$	$V_{DD} + 0.5$	V	-
Input high voltage (Special Threshold)	$V_{IHS}SR$	$0.8 V_{DD}$ -0.2	$V_{DD} + 0.5$	V	-
Input Hysteresis (Special Threshold)	HYS	400	-	mV	-
Output low voltage (PORT0, PORT1, Port 4, ALE, \overline{RD} , WR, BHE, CLKOUT, RSTOUT)	V_{OLCC}	-	0.45	V	$I_{OL} = 2.4\text{ mA}$
Output low voltage (all other outputs)	$V_{OL1}CC$	-	0.45	V	$I_{OL1} = 1.6\text{ mA}$
Output high voltage (PORT0, PORT1, Port 4, ALE, \overline{RD} , WR, BHE, CLKOUT, RSTOUT)	V_{OHCC}	$0.9 V_{DD}$ 2.4	-	V	$I_{OH} = -500\text{ }\mu\text{A}$ $I_{OH} = -2.4\text{ mA}$
Output high voltage ¹⁾ (all other outputs)	$V_{OH1}CC$	$0.9 V_{DD}$ 2.4	-	V V	$I_{OH} = -250\text{ }\mu\text{A}$ $I_{OH} = -1.6\text{ mA}$
Input leakage current (Port 5)	$I_{OZ1}CC$	-	± 1	μA	$0.45\text{V} < V_{IN} < V_{DD}$
Input leakage current (all other)	$I_{OZ2}CC$	-	± 1	μA	$0.45\text{V} < V_{IN} < V_{DD}$
Overload current	$I_{OV}SR$	-	± 5	mA	5) 8)
\overline{RSTIN} pullup resistor	$R_{RST}CC$	50	250	k Ω	-
Read/Write inactive current ⁴⁾	I_{RWH} ²⁾	-	-40	μA	$V_{OUT} = 2.4\text{ V}$
Read/Write active current ⁴⁾	I_{RWL} ³⁾	-500	-	μA	$V_{OUT} = V_{OLmax}$
ALE inactive current ⁴⁾	I_{ALEL} ²⁾	-	30	μA	$V_{OUT} = V_{OLmax}$
ALE active current ⁴⁾	I_{ALEH} ³⁾	500	-	μA	$V_{OUT} = 2.4\text{ V}$
Port 6 inactive current ⁴⁾	I_{P6H} ²⁾	-	-40	μA	$V_{OUT} = 2.4\text{ V}$
Port 6 active current ⁴⁾	I_{P6L} ³⁾	-500	-	μA	$V_{OUT} = V_{OL1max}$

Table 20.1 DC Parametric (cont'd)

Parameter	Symbol	Limit Values		Unit	Test Condition
		min.	max.		
PORT0 configuration current ⁴⁾	I_{POH} ²⁾	–	-10	μA	$V_{IN} = V_{IHmin}$
	I_{POL} ³⁾	-100	–	μA	$V_{IN} = V_{ILmax}$
XTAL1 input current	I_{IL} CC	–	± 20	μA	$0\text{ V} < V_{IN} < V_{DD}$
Pin capacitance ⁵⁾ (digital inputs/outputs)	C_{IO} CC	–	10	pF	$f = 1\text{ MHz}$ $T_A = 25\text{ }^\circ\text{C}$
Power supply current	I_{CC}	–	120 + $5 * f_{CPU}$	mA	$\overline{RSTIN} = V_{IL}$ f_{CPU} in [MHz] ⁶⁾
Idle mode supply current	I_{ID}	–	40 + $2 * f_{CPU}$	mA	$\overline{RSTIN} = V_{IH1}$ f_{CPU} in [MHz] ⁶⁾
Power-down mode supply current	I_{PD}	–	100	μA	$V_{DD} = 5.25\text{ V}$ ⁷⁾
V_{PP} Read Current	I_{PPR}	-	200	μA	$V_{PP} < V_{DD}$
V_{PP} Write Current	I_{PPW}	-	50	mA	at 20MHz 32-Bit programming $V_{PP} = 12\text{ V}$
V_{PP} during Write/Read	V_{PP}	11.4	12.6	V	

- Notes
- 1: This specification is not valid for outputs which are switched to open drain mode. In this case the respective output will float and the voltage results from the external circuitry.
 - 2: The maximum current may be drawn while the respective signal line remains inactive.
 - 3: The minimum current must be drawn in order to drive the respective signal line active.
 - 4: This specification is only valid during Reset, or during Hold- or Adapt-mode. Port 6 pins are only affected, if they are used for \overline{CS} output and the open drain function is not enabled.
 - 5: Not 100% tested, guaranteed by design characterization.
 - 6: The supply current is a function of the operating frequency. This dependency is illustrated in the figure below.
These parameters are tested at V_{DDmax} and 20 MHz CPU clock with all outputs disconnected and all inputs at V_{IL} or V_{IH} .
 - 7: This parameter is tested including leakage currents. All inputs (including pins configured as inputs) at 0 V to 0.1 V or at $V_{DD} - 0.1\text{ V}$ to V_{DD} , $V_{REF} = 0\text{ V}$, all outputs (including pins configured as outputs) disconnected.
 - 8: Overload conditions occur if the standard operating conditions are exceeded, i.e. the voltage on any pin exceeds the specified range (i.e. $V_{OV} > V_{DD} + 0.5\text{ V}$ or $V_{OV} < V_{SS} - 0.5\text{ V}$). The absolute sum of input overload currents on all port pins may not exceed **50 mA**.
 - 9: Power Down Current is to be defined.

Figure 20.1 Supply/Idle Current as a Function of Operating Frequency

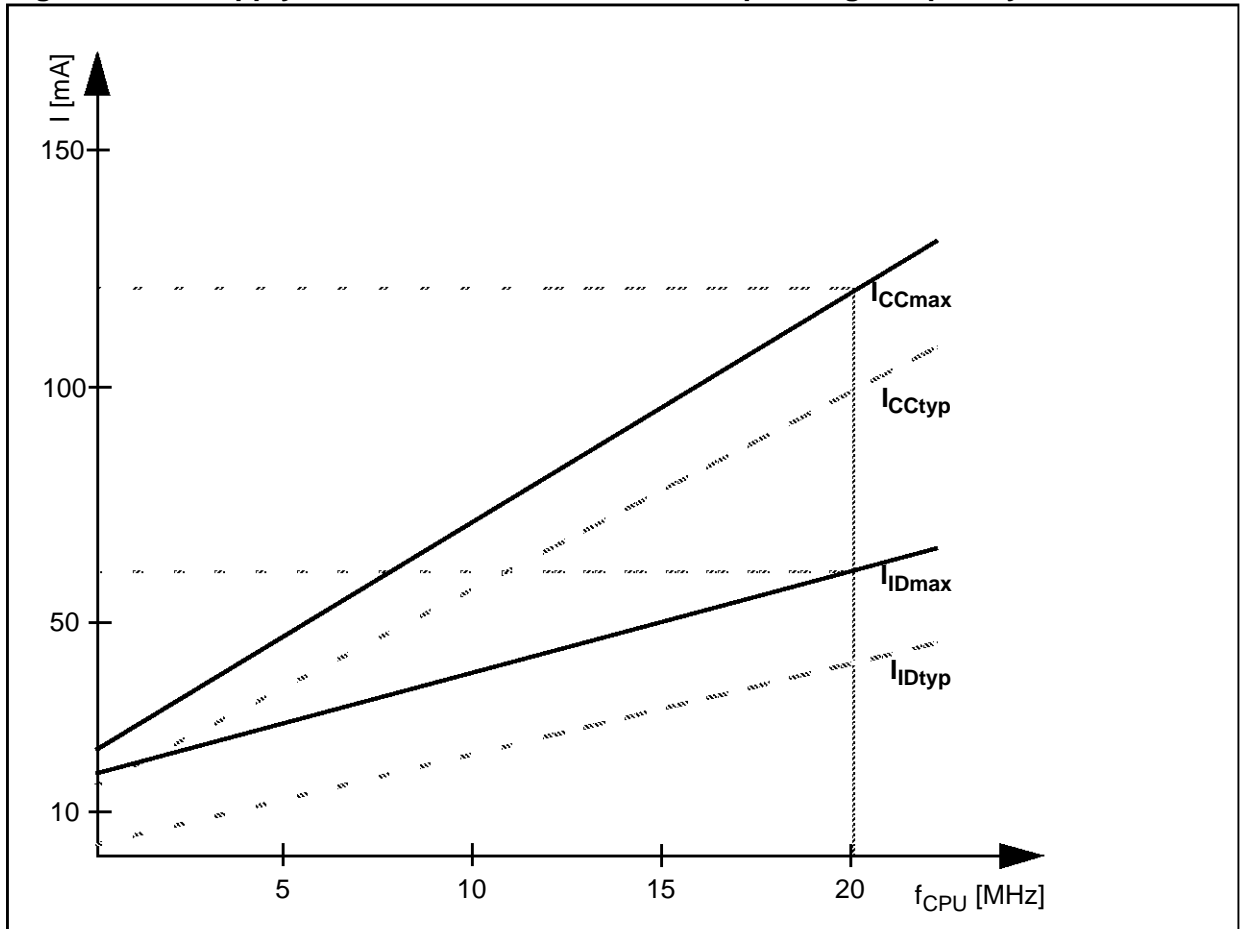

20.4 A/D Converter Characteristics

$V_{DD} = 5\text{ V} \pm 5\%$, $V_{SS} = 0\text{ V}$, $T_A = -40\text{ to }+85\text{ }^\circ\text{C}$

$4.0\text{ V} \leq V_{AREF} \leq V_{DD} + 0.1\text{ V}$, $V_{SS} - 0.1\text{ V} \leq V_{AGND} \leq V_{SS} + 0.2\text{ V}$

Table 20.2 A/D Converter Characteristics

Parameter	Symbol		Limit Values		Unit	Test Condition
			min.	max.		
Analog input voltage range	V_{AIN}	SR	V_{AGND}	V_{AREF}	V	1)
Sample time	t_S	CC	–	$2 t_{SC}$		2) 4)
Conversion time	t_C	CC	–	$14 t_{CC} + t_S + 4TCL$		3) 4)
Total unadjusted error	TUE	CC	–	± 3	LSB	5)
Internal resistance of reference voltage source	R_{AREF}	SR	–	$t_{CC} / 165 - 0.25$	$k\Omega$	t_{CC} in [ns] 6) 7)
Internal resistance of analog source	R_{ASRC}	SR	–	$t_S / 330 - 0.25$	$k\Omega$	t_S in [ns] 2) 7)
ADC input capacitance	C_{AIN}	CC	–	33	pF	7)

Sample time and conversion time of the ST10F167's ADC are programmable. Table 20.3 shows the timing calculations.

Table 20.3 Sample and Conversion Time Calculations

ADCON.15 14 (ADCTC)	Conversion clock t_{CC}	ADCON.13 12 (ADSTC)	Sample clock t_{SC}
00	TCL * 24	00	t_{CC}
01	Reserved, do not use	01	$t_{CC} * 2$
10	TCL * 96	10	$t_{CC} * 4$
11	TCL * 48	11	$t_{CC} * 8$

Notes 1: V_{AIN} may exceed V_{AGND} or V_{AREF} up to the absolute maximum ratings. However, the conversion result in these cases will be X000_H or X3FF_H, respectively.

2: During the sample time the input capacitance C_I can be charged/discharged by the external source. The internal resistance of the analog source must allow the capacitance to reach its final voltage level within t_S . After the end of the sample time t_S , changes of the analog input voltage have no effect on the conversion result.

Values for the sample clock t_{SC} depend on programming and can be taken from the table above.

3: This parameter includes the sample time t_S , the time for determining the digital result and the time to load the result register with the conversion result.

Values for the conversion clock t_{CC} depend on programming and can be taken from the table above.

4: This parameter depends on the ADC control logic. It is not a real maximum value, but rather a

fixum.

5:TUE is tested at $V_{AREF}=5.0V$, $V_{AGND}=0V$, $V_{DD}=4.9V$. It is guaranteed by design characterization for all other voltages within the defined voltage range.

The specified TUE is guaranteed only if an overload condition (see I_{OV} specification) occurs on maximum 2 not selected analog input pins and the absolute sum of input overload currents on all analog input pins does not exceed 10 mA.

During the reset calibration sequence the maximum TUE may be ± 4 LSB.

6:During the conversion the ADC's capacitance must be repeatedly charged or discharged. The internal resistance of the reference voltage source must allow the capacitance to reach its respective voltage level within t_{CC} . The maximum internal resistance results from the programmed conversion timing.

7:Not 100% tested, guaranteed by design characterization.

20.5 AC Characteristics

20.5.1 Test Waveforms

Figure 20.2 Input Output Waveforms

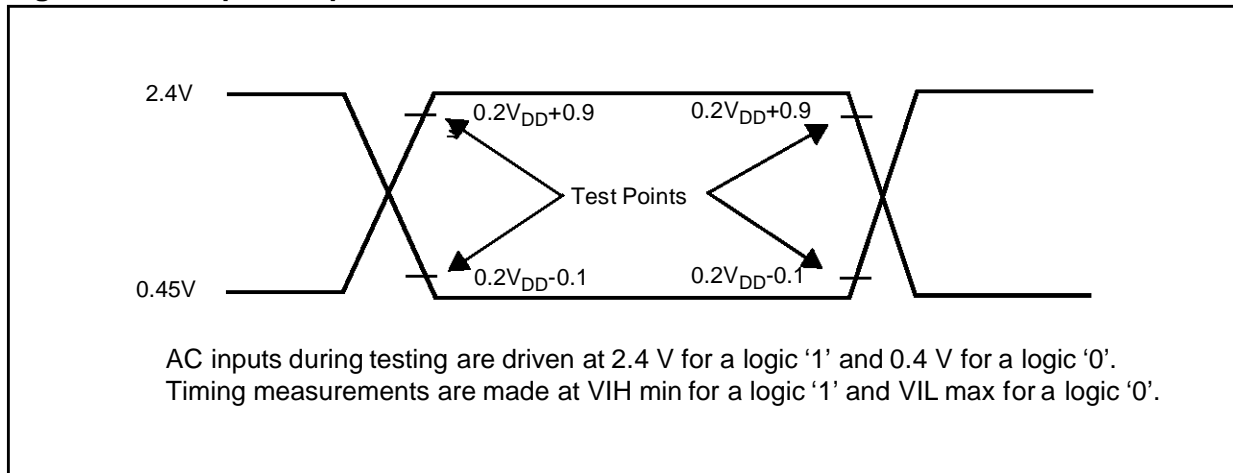
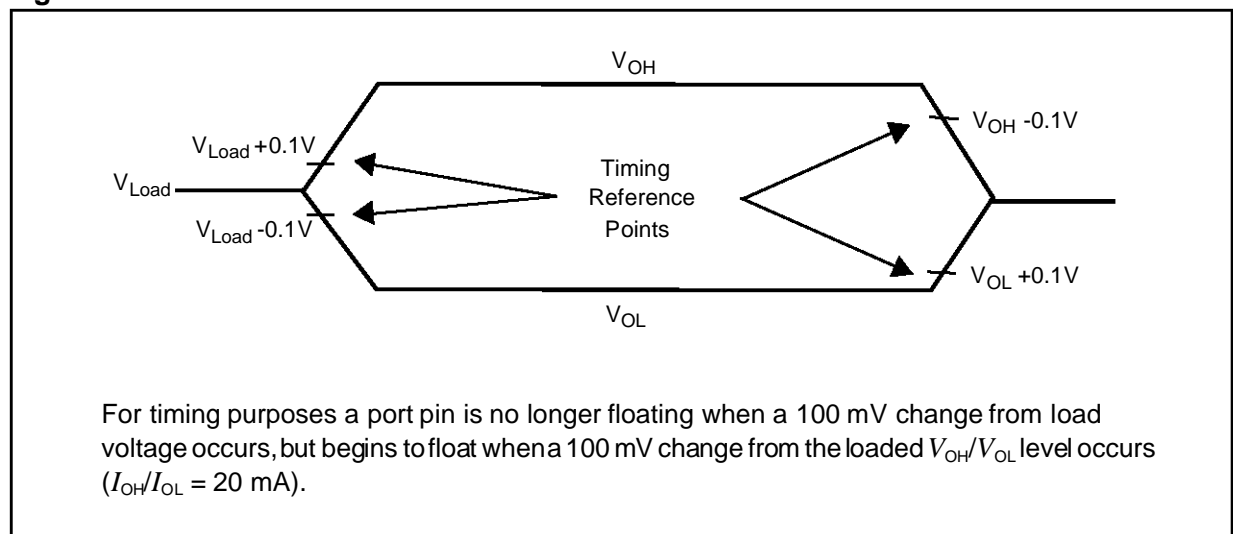

Figure 20.3 Float Waveforms



20.5.2 Definition of Internal Timing

The internal operation of the ST10F167 is controlled by the internal CPU clock f_{CPU} . Both edges of the CPU clock can trigger internal (e.g. pipeline) or external (e.g. bus cycles) operations.

The specification of the external timing (AC Characteristics) therefore depends on the time between two consecutive edges of the CPU clock, called "TCL" (see Figure 20.4).

The CPU clock signal can be generated via different mechanisms. The duration of TCLs and their variation (and also the derived external timing) depends on the mechanism used to generate f_{CPU} . This influence must be taken into consideration when calculating the timings for the ST10F167.

Figure 20.4 Generation Mechanisms for the CPU Clock

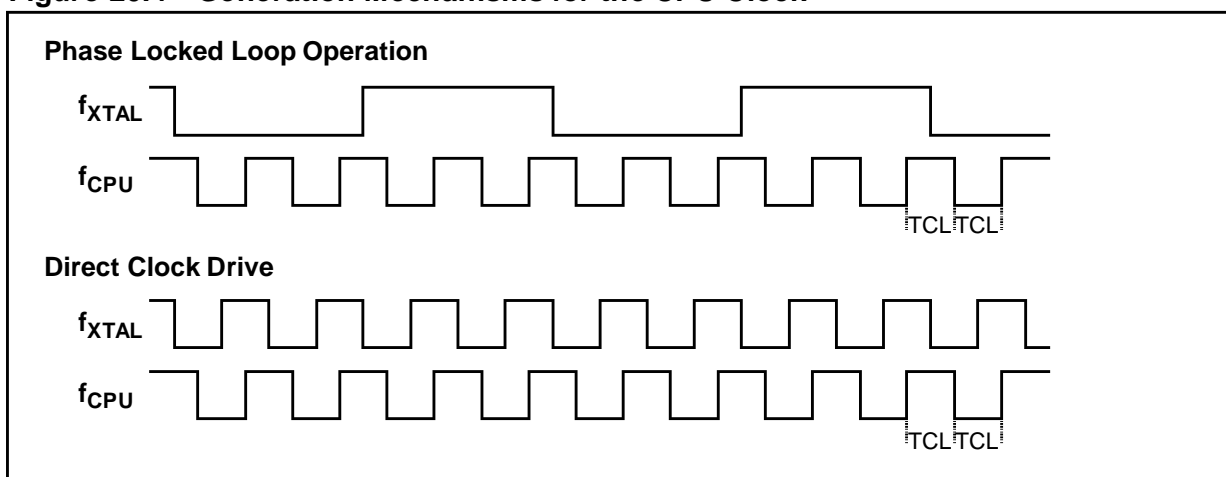

20.5.3 Direct Drive

When pin P0.15 (P0H.7) is low ('0') during reset the on-chip phase locked loop is disabled and the CPU clock is directly driven from the oscillator with the input clock signal.

The frequency of f_{CPU} directly follows the frequency of f_{XTAL} so the high and low time of f_{CPU} (i.e. the duration of an individual TCL) is defined by the duty cycle of the input clock f_{XTAL} .

The timings listed below that refer to TCLs therefore must be calculated using the minimum TCL that is possible under the respective circumstances. This minimum value can be calculated via the following formula:

$$TCL_{min} = 1/f_{XTAL} * DC_{min}$$

DC = duty cycle

For two consecutive TCLs the deviation caused by the duty cycle of f_{XTAL} is compensated so the duration of 2TCL is always $1/f_{XTAL}$. The minimum value TCL_{min} therefore has to be used only once for timings that require an odd number of TCLs (1,3,...). Timings that require an even number of TCLs (2,4,...) may use the formula:

$$2TCL = 1/f_{XTAL}$$

Note: The address float timings in Multiplexed bus mode (t_{11} and t_{45}) use the maximum duration of TCL ($TCL_{max} = 1/f_{XTAL} * DC_{max}$) instead of TCL_{min} .

20.5.4 Phase Locked Loop

When pin P0.15 (POH.7) is high ('1') during reset the on-chip phase locked loop is enabled and provides the CPU clock. The PLL multiplies the input frequency by 4 (i.e. $f_{CPU} = f_{XTAL} * 4$). With every fourth transition of f_{XTAL} the PLL circuit synchronizes the CPU clock to the input clock. This synchronization is done smoothly, i.e. the CPU clock frequency does not change abruptly.

Due to this adaptation to the input clock the frequency of f_{CPU} is constantly adjusted so it is locked to f_{XTAL} . The slight variation causes a jitter of f_{CPU} which also effects the duration of individual TCLs.

The timings listed in the AC Characteristics that refer to TCLs therefore must be calculated using the minimum TCL that is possible under the respective circumstances.

The actual minimum value for TCL depends on the jitter of the PLL. As the PLL is constantly adjusting its output frequency so that it remains locked to the applied input frequency (crystal or oscillator) the relative deviation for periods of more than one TCL is lower than for one single TCL (see formula and figure below).

For a period of $N * TCL$ the minimum value is computed using the corresponding deviation D_N :

$$TCL_{min} = TCL_{NOM} * (1 - |D_N|) \text{ § } 100$$

$$D_N = \pm(4 - N/15) [\%]$$

where N = number of consecutive TCLs and $1 \leq N \leq 40$.

So for a period of 3 TCLs (i.e. $N = 3$):

$$D_3 = 4 - 3/15$$

$$= 3.8\%$$

$$TCL_{min} = TCL_{NOM} \times (1 - 3.8/100)$$

$$= TCL_{NOM} \times 0.962$$

$$(24.1 \text{ nsec} @ f_{CPU} = 20 \text{ MHz})$$

This is especially important for bus cycles using waitstates and e.g. for the operation of timers, serial interfaces, etc. For all slower operations and longer periods (e.g. pulse train generation or measurement, lower baudrates, etc.) the deviation caused by the PLL jitter is negligible.

Figure 20.5 Approximated Maximum PLL Jitter

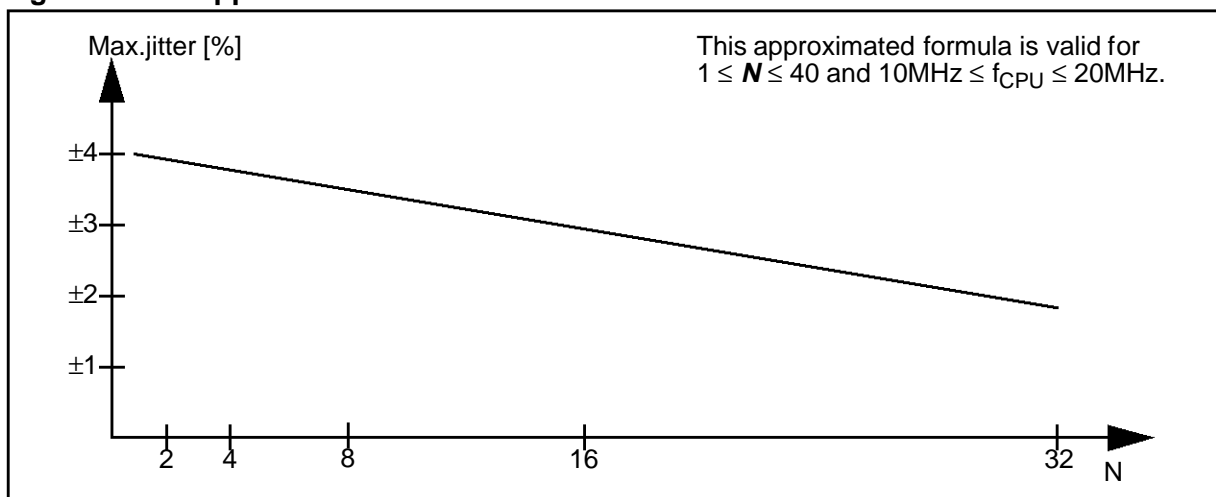

20.5.5 External Clock Drive XTAL1

$V_{DD} = 5\text{ V} \pm 5\%$, $V_{SS} = 0\text{ V}$, $T_A = -40\text{ to }+85\text{ }^\circ\text{C}$

Table 20.4 External Clock Drive Characteristics

Parameter	Symbol	Direct Drive 1:1		PLL 1:4		Unit
		min.	max.	min.	max.	
Oscillator period	t_{OSC} SR	50 ¹⁾	1000	200	333	ns
High time	t_1 SR	25	–	6	–	ns
Low time	t_2 SR	25	–	6	–	ns
Rise time	t_3 SR	–	10	–	10	ns
Fall time	t_4 SR	–	10	–	10	ns

1) Theoretical minimum. The real minimum value depends on the duty cycle of the input clock signal.

Figure 20.6 External Clock Drive XTAL1

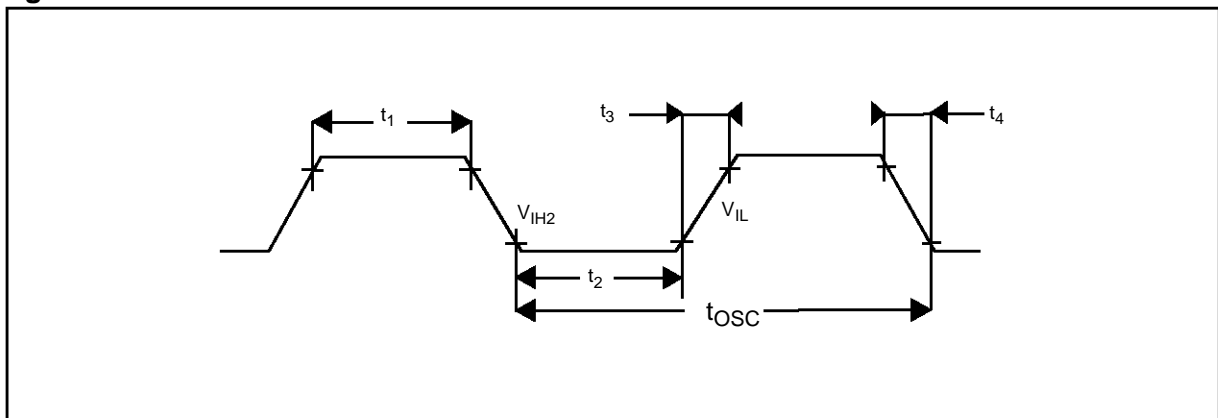

20.5.6 Memory Cycle Variables

The timing tables below use three variables which are derived from the BUSCONx registers and represent the special characteristics of the pro-

grammed memory cycle. The following table describes, how these variables are to be computed.

Table 20.5 Memory Cycle Variable Definition

Description	Symbol	Values
ALE Extension	t_A	$TCL * \langle ALECTL \rangle$
Memory Cycle Time Waitstates	t_C	$2TCL * (15 - \langle MCTC \rangle)$
Memory Tristate Time	t_F	$2TCL * (1 - \langle MTTC \rangle)$

20.5.7 Multiplexed Bus

$V_{DD} = 5 V \pm 5\%$, $V_{SS} = 0 V$, $T_A = -40$ to $+85$ °C

C_L (for PORT0, PORT1, Port 4, ALE, \overline{RD} , \overline{WR} , \overline{BHE} , CLKOUT) = 100 pF, C_L (for Port 6, \overline{CS}) = 100 pF

ALE cycle time = $6 \text{ TCL} + 2t_A + t_C + t_F$ (150 ns at 20-MHz CPU clock without waitstates)

Table 20.6 Multiplexed Bus Characteristics

Parameter	Symbol	Max. CPU Clock = 20 MHz		Variable CPU Clock 1/2TCL = 1 to 20 MHz		Unit
		min.	max.	min.	max.	
ALE high time	t_5 CC	$15 + t_A$	–	$\text{TCL} - 10 + t_A$	–	ns
Address setup to ALE	t_6 CC	$0 + t_A$	–	$\text{TCL} - 25 + t_A$	–	ns
Address hold after ALE	t_7 CC	$15 + t_A$	–	$\text{TCL} - 10 + t_A$	–	ns
ALE falling edge to \overline{RD} , \overline{WR} (with RW-delay)	t_8 CC	$15 + t_A$	–	$\text{TCL} - 10 + t_A$	–	ns
ALE falling edge to \overline{RD} , \overline{WR} (no RW-delay)	t_9 CC	$-10 + t_A$	–	$-10 + t_A$	–	ns
Address float after \overline{RD} , \overline{WR} (with RW-delay)	t_{10} CC	–	5	–	5	ns
Address float after \overline{RD} , \overline{WR} (no RW-delay)	t_{11} CC	–	30	–	$\text{TCL} + 5$	ns
\overline{RD} , \overline{WR} low time (with RW-delay)	t_{12} CC	$25 + t_C$	–	$2\text{TCL} - 25$ $+ t_C$	–	ns
\overline{RD} , \overline{WR} low time (no RW-delay)	t_{13} CC	$65 + t_C$	–	$3\text{TCL} - 10$ $+ t_C$	–	ns
\overline{RD} to valid data in (with RW-delay)	t_{14} SR	–	$5 + t_C$	–	$2\text{TCL} - 45$ $+ t_C$	ns
\overline{RD} to valid data in (no RW-delay)	t_{15} SR	–	$55 + t_C$	–	$3\text{TCL} - 20$ $+ t_C$	ns
ALE low to valid data in	t_{16} SR	–	$40 + t_A + t_C$	–	$3\text{TCL} - 35$ $+ t_A + t_C$	ns
Address to valid data in	t_{17} SR	–	60 $+ 2t_A + t_C$	–	$4\text{TCL} - 40$ $+ 2t_A + t_C$	ns
Data hold after \overline{RD} rising edge	t_{18} SR	0	–	0	–	ns
Data float after \overline{RD}	t_{19} SR	–	$35 + t_F$	–	$2\text{TCL} - 15 + t_F$	ns
Data valid to \overline{WR}	t_{22} SR	$15 + t_C$	–	$2\text{TCL} - 35$ $+ t_C$	–	ns
Data hold after \overline{WR}	t_{23} CC	$35 + t_F$	–	$2\text{TCL} - 15$ $+ t_F$	–	ns
ALE rising edge after \overline{RD} , \overline{WR}	t_{25} CC	$35 + t_F$	–	$2\text{TCL} - 15$ $+ t_F$	–	ns
Address hold after \overline{RD} , \overline{WR}	t_{27} CC	$35 + t_F$	–	$2\text{TCL} - 15 + t_F$	–	ns

Table 20.6 Multiplexed Bus Characteristics (cont'd)

Parameter	Symbol	Max. CPU Clock = 20 MHz		Variable CPU Clock 1/2TCL = 1 to 20 MHz		Unit
		min.	max.	min.	max.	
ALE falling edge to \overline{CS}	t_{38} CC	$-5 - t_A$	$10 - t_A$	$-5 - t_A$	$10 - t_A$	ns
\overline{CS} low to Valid Data In	t_{39} SR	–	$45 + t_C + 2t_A$	–	$3TCL - 30 + t_C + 2t_A$	ns
\overline{CS} hold after RD, WR	t_{40} CC	$60 + t_F$	–	$3TCL - 15 + t_F$	–	ns
ALE fall. edge to \overline{RdCS} , \overline{WrCS} (with RW delay)	t_{42} CC	$20 + t_A$	–	$TCL - 5 + t_A$	–	ns
ALE fall. edge to \overline{RdCS} , \overline{WrCS} (no RW delay)	t_{43} CC	$-5 + t_A$	–	$-5 + t_A$	–	ns
Address float after \overline{RdCS} , \overline{WrCS} (with RW delay)	t_{44} CC	–	0	–	0	ns
Address float after \overline{RdCS} , \overline{WrCS} (no RW delay)	t_{45} CC	–	25	–	TCL	ns
\overline{RdCS} to Valid Data In (with RW delay)	t_{46} SR	–	$15 + t_C$	–	$2TCL - 35 + t_C$	ns
\overline{RdCS} to Valid Data In (no RW delay)	t_{47} SR	–	$50 + t_C$	–	$3TCL - 25 + t_C$	ns
\overline{RdCS} , \overline{WrCS} Low Time (with RW delay)	t_{48} CC	$40 + t_C$	–	$2TCL - 10 + t_C$	–	ns
\overline{RdCS} , \overline{WrCS} Low Time (no RW delay)	t_{49} CC	$65 + t_C$	–	$3TCL - 10 + t_C$	–	ns
Data valid to \overline{WrCS}	t_{50} CC	$35 + t_C$	–	$2TCL - 15 + t_C$	–	ns
Data hold after \overline{RdCS}	t_{51} SR	0	–	0	–	ns
Data float after \overline{RdCS}	t_{52} SR	–	$30 + t_F$	–	$2TCL - 20 + t_F$	ns
Address hold after \overline{RdCS} , \overline{WrCS}	t_{54} CC	$30 + t_F$	–	$2TCL - 20 + t_F$	–	ns
Data hold after \overline{WrCS}	t_{56} CC	$30 + t_F$	–	$2TCL - 20 + t_F$	–	ns

Figure 20.7 External Memory Cycle: Multiplexed Bus, With Read/Write Delay, Normal ALE

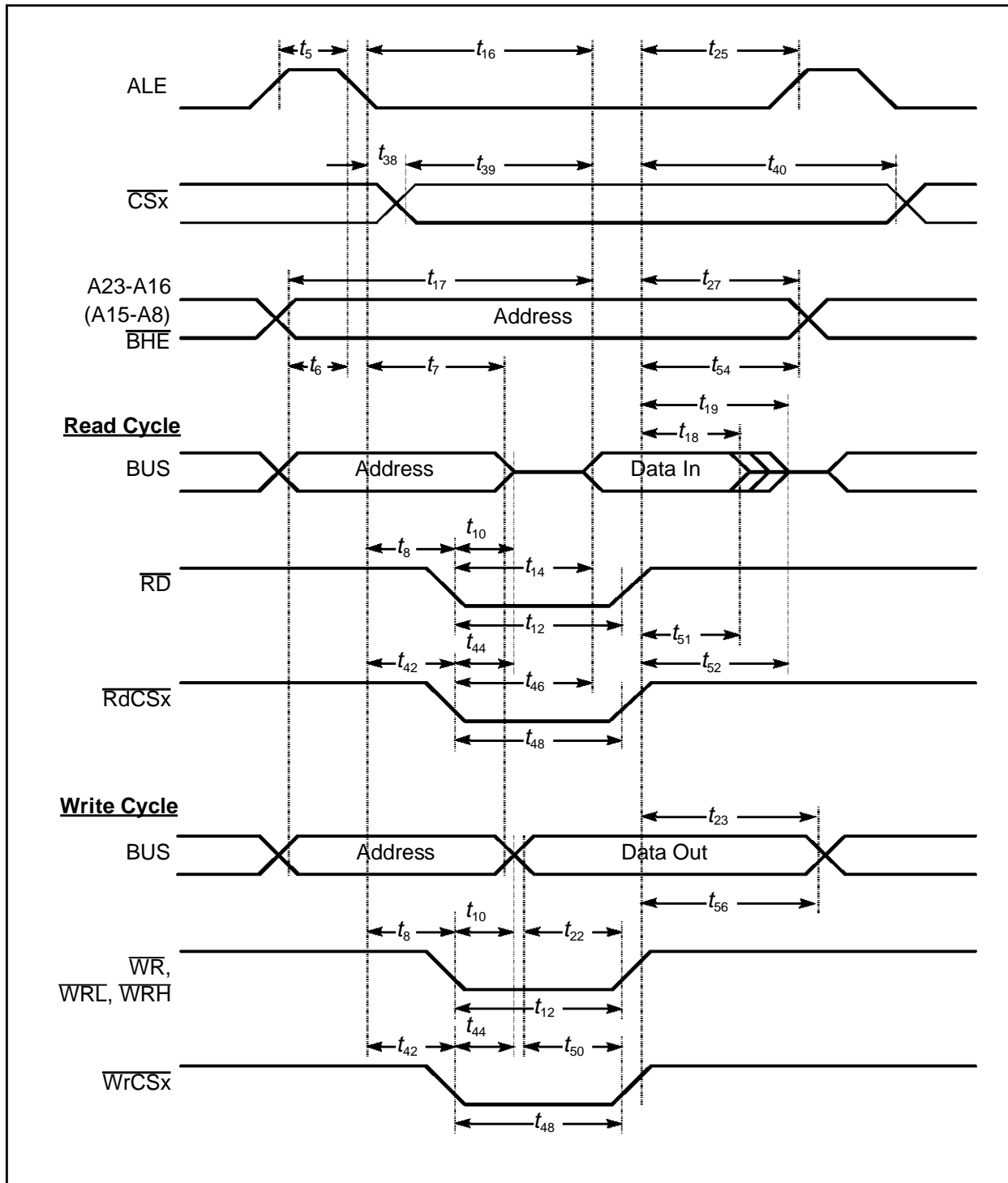

Figure 20.8 External Memory Cycle: Multiplexed Bus, With Read/Write Delay, Extended ALE

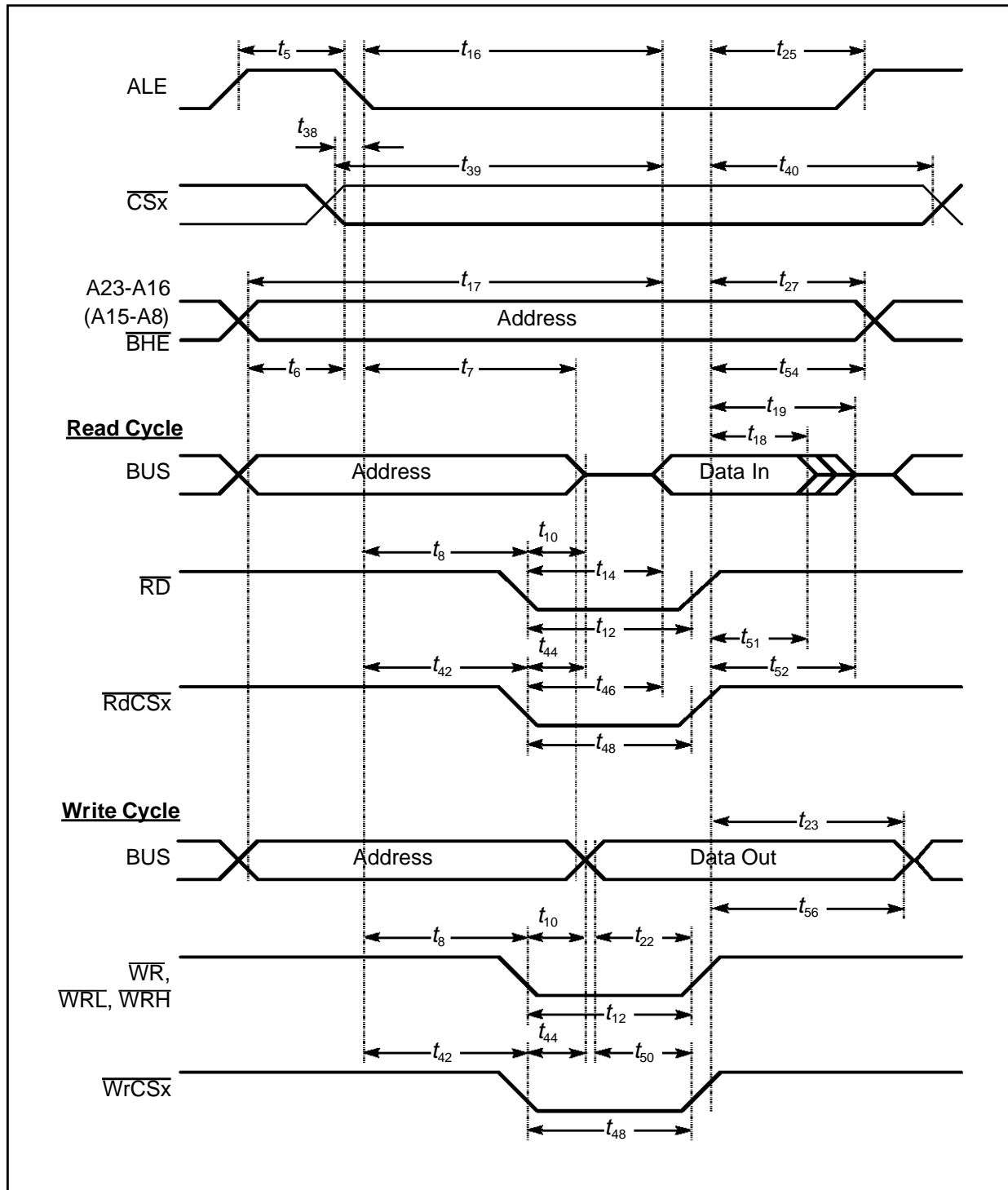

Figure 20.9 External Memory Cycle: Multiplexed Bus, No Read/Write Delay, Normal ALE

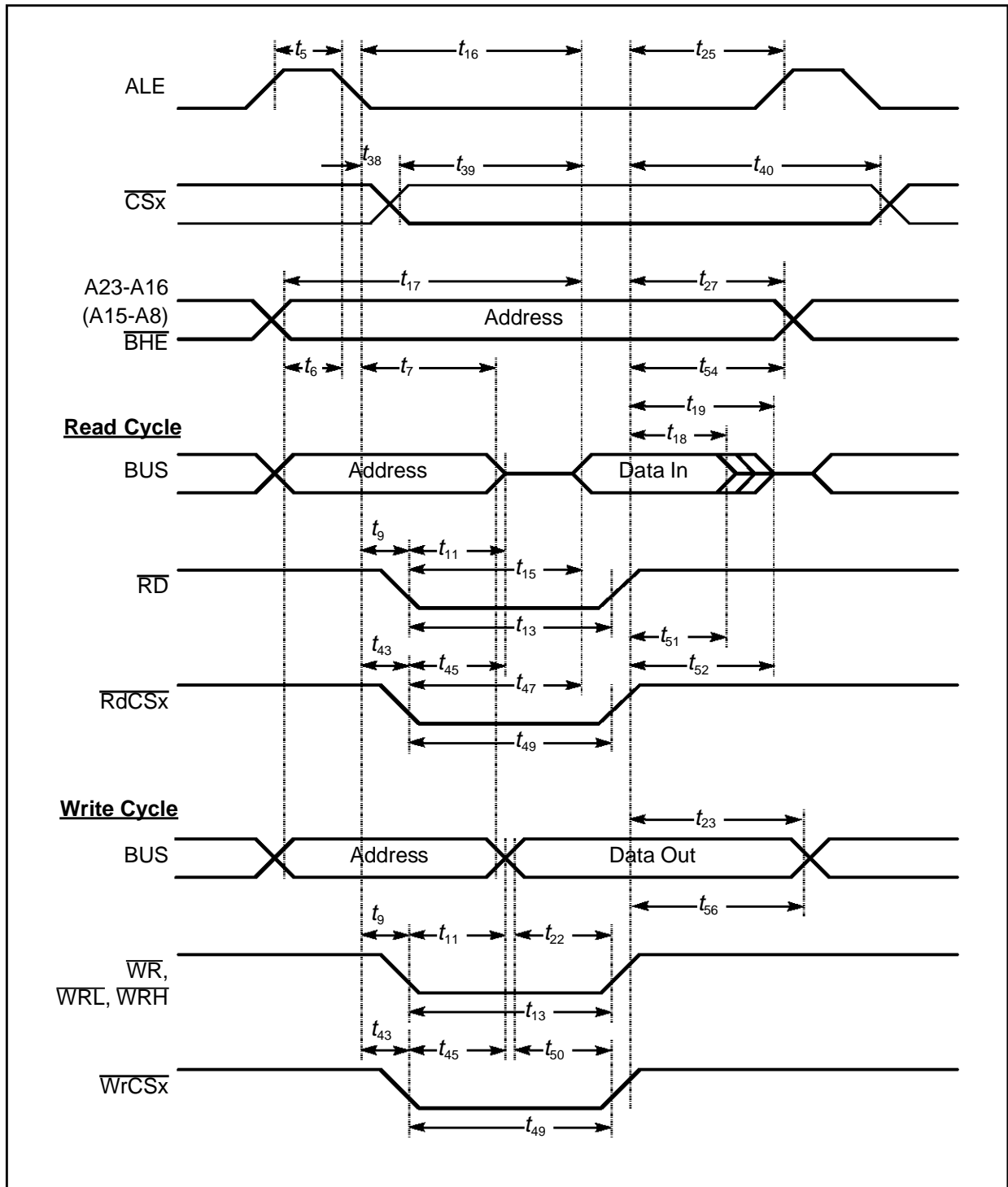
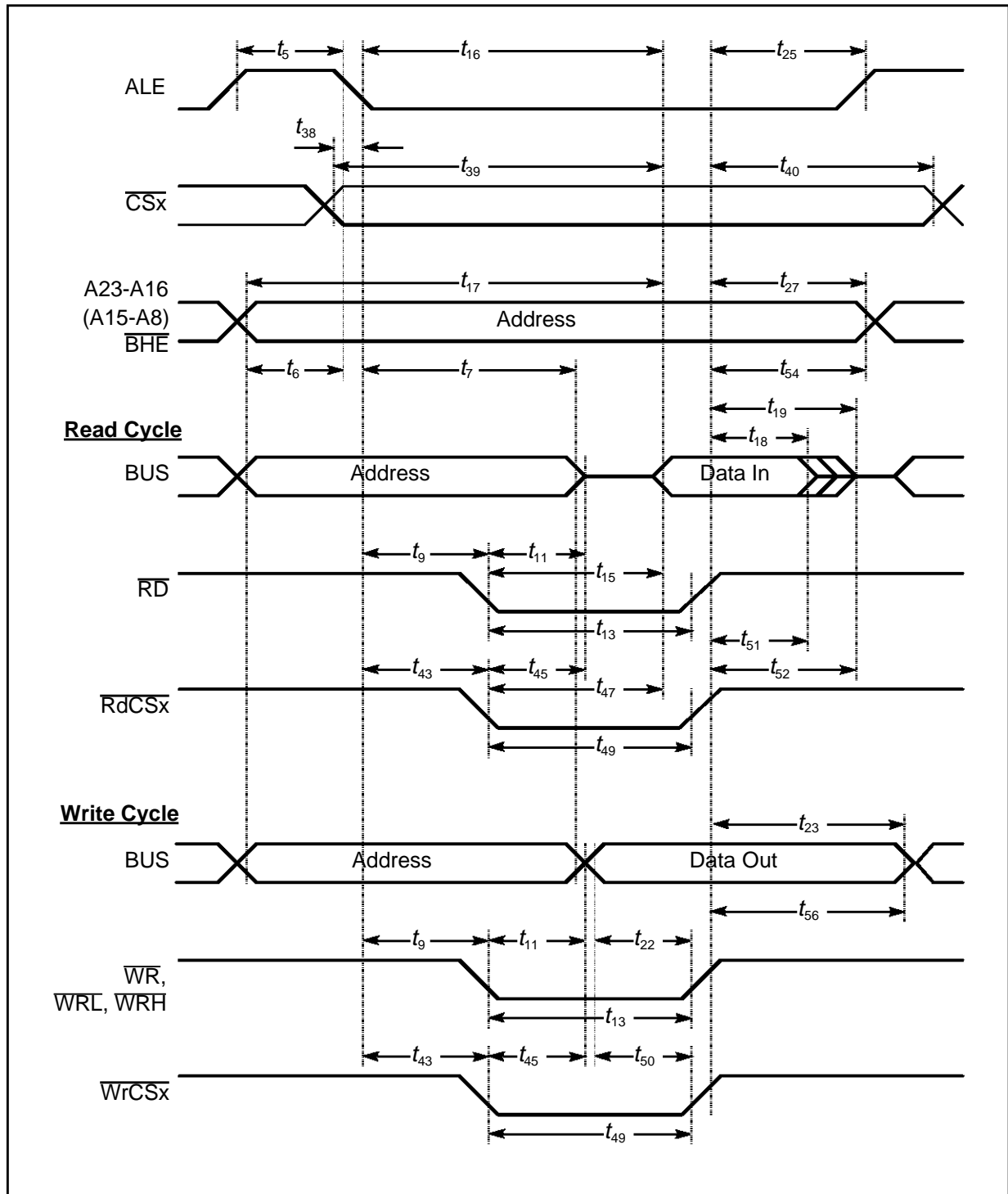

Figure 20.10 External Memory Cycle: Multiplexed Bus, No Read/Write Delay, Extended ALE



20.5.8 Demultiplexed Bus

$V_{DD} = 5\text{ V} \pm 5\%$, $V_{SS} = 0\text{ V}$, $T_A = -40\text{ to }+85\text{ }^\circ\text{C}$

C_L (for PORT0, PORT1, Port 4, ALE, \overline{RD} , \overline{WR} , \overline{BHE} , CLKOUT) = 100 pF, C_L (for Port 6, \overline{CS}) = 100 pF

ALE cycle time = $4\text{ TCL} + 2t_A + t_C + t_F$ (100 ns at 20-MHz CPU clock without waitstates)

Table 20.7 Demultiplexed Bus Characteristics

Parameter	Symbol	Max. CPU Clock = 20 MHz		Variable CPU Clock 1/2TCL = 1 to 20 MHz		Unit
		min.	max.	min.	max.	
ALE high time	t_5 CC	$15 + t_A$	–	$\text{TCL} - 10 + t_A$	–	ns
Address setup to ALE	t_6 CC	$0 + t_A$	–	$\text{TCL} - 25 + t_A$	–	ns
ALE falling edge to \overline{RD} , \overline{WR} (with RW-delay)	t_8 CC	$15 + t_A$	–	$\text{TCL} - 10$ $+ t_A$	–	ns
ALE falling edge to \overline{RD} , \overline{WR} (no RW-delay)	t_9 CC	$-10 + t_A$	–	$-10 + t_A$	–	ns
\overline{RD} , \overline{WR} low time (with RW-delay)	t_{12} CC	$25 + t_C$	–	$2\text{TCL} - 25$ $+ t_C$	–	ns
\overline{RD} , \overline{WR} low time (no RW-delay)	t_{13} CC	$65 + t_C$	–	$3\text{TCL} - 10$ $+ t_C$	–	ns
\overline{RD} to valid data in (with RW-delay)	t_{14} SR	–	$5 + t_C$	–	$2\text{TCL} - 45$ $+ t_C$	ns
\overline{RD} to valid data in (no RW-delay)	t_{15} SR	–	$55 + t_C$	–	$3\text{TCL} - 20$ $+ t_C$	ns
ALE low to valid data in	t_{16} SR	–	40 $+ t_A + t_C$	–	$3\text{TCL} - 35$ $+ t_A + t_C$	ns
Address to valid data in	t_{17} SR	–	60 $+ 2t_A + t_C$	–	$4\text{TCL} - 40$ $+ 2t_A + t_C$	ns
Data hold after \overline{RD} rising edge	t_{18} SR	0	–	0	–	ns
Data float after \overline{RD} rising edge (with RW-delay)	t_{20} SR	–	$35 + t_F$	–	$2\text{TCL} - 15$ $+ t_F$	ns
Data float after \overline{RD} rising edge (no RW-delay)	t_{21} SR	–	$15 + t_F$	–	$\text{TCL} - 10$ $+ t_F$	ns
Data valid to \overline{WR}	t_{22} CC	$15 + t_C$	–	$2\text{TCL} - 35$ $+ t_C$	–	ns
Data hold after \overline{WR}	t_{24} CC	$15 + t_F$	–	$\text{TCL} - 10 + t_F$	–	ns
ALE rising edge after \overline{RD} , \overline{WR}	t_{26} CC	$-10 + t_F$	–	-10 $+ t_F$	–	ns
Address hold after \overline{RD} , \overline{WR}	t_{28} CC	$-2.5 + t_F$	–	$-2.5 + t_F$	–	ns
ALE falling edge to \overline{CS}	t_{38} CC	$-5 - t_A$	$10 - t_A$	$-5 - t_A$	$10 - t_A$	ns
\overline{CS} low to Valid Data In	t_{39} SR	–	45 $+ t_C + 2t_A$	–	$3\text{TCL} - 30$ $+ t_C + 2t_A$	ns

Table 20.7 Demultiplexed Bus Characteristics (cont'd)

Parameter	Symbol	Max. CPU Clock = 20 MHz		Variable CPU Clock 1/2TCL = 1 to 20 MHz		Unit
		min.	max.	min.	max.	
\overline{CS} hold after \overline{RD} , \overline{WR}	t_{41} CC	$10 + t_F$	–	$TCL - 15 + t_F$	–	ns
ALE falling edge to \overline{RdCS} , \overline{WrCS} (with RW-delay)	t_{42} CC	$20 + t_A$	–	$TCL - 5 + t_A$	–	ns
ALE falling edge to \overline{RdCS} , \overline{WrCS} (no RW-delay)	t_{43} CC	$-5 + t_A$	–	$-5 + t_A$	–	ns
\overline{RdCS} to Valid Data In (with RW-delay)	t_{46} SR	–	$15 + t_C$	–	$2TCL - 35 + t_C$	ns
\overline{RdCS} to Valid Data In (no RW-delay)	t_{47} SR	–	$50 + t_C$	–	$3TCL - 25 + t_C$	ns
\overline{RdCS} , \overline{WrCS} Low Time (with RW-delay)	t_{48} CC	$40 + t_C$	–	$2TCL - 10 + t_C$	–	ns
\overline{RdCS} , \overline{WrCS} Low Time (no RW-delay)	t_{49} CC	$65 + t_C$	–	$3TCL - 10 + t_C$	–	ns
Data valid to \overline{WrCS}	t_{50} CC	$35 + t_C$	–	$2TCL - 15 + t_C$	–	ns
Data hold after \overline{RdCS}	t_{51} SR	0	–	0	–	ns
Data float after \overline{RdCS} (with RW-delay)	t_{53} SR	–	$30 + t_F$	–	$2TCL - 20 + t_F$	ns
Data float after \overline{RdCS} (no RW-delay)	t_{68} SR	–	$5 + t_F$	–	$TCL - 20 + t_F$	ns
Address hold after \overline{RdCS} , \overline{WrCS}	t_{55} CC	$-10 + t_F$	–	$-10 + t_F$	–	ns
Data hold after \overline{WrCS}	t_{57} CC	$10 + t_F$	–	$TCL - 15 + t_F$	–	ns

Figure 20.11 External Memory Cycle: Demultiplexed Bus, With Read/Write Delay, Normal ALE

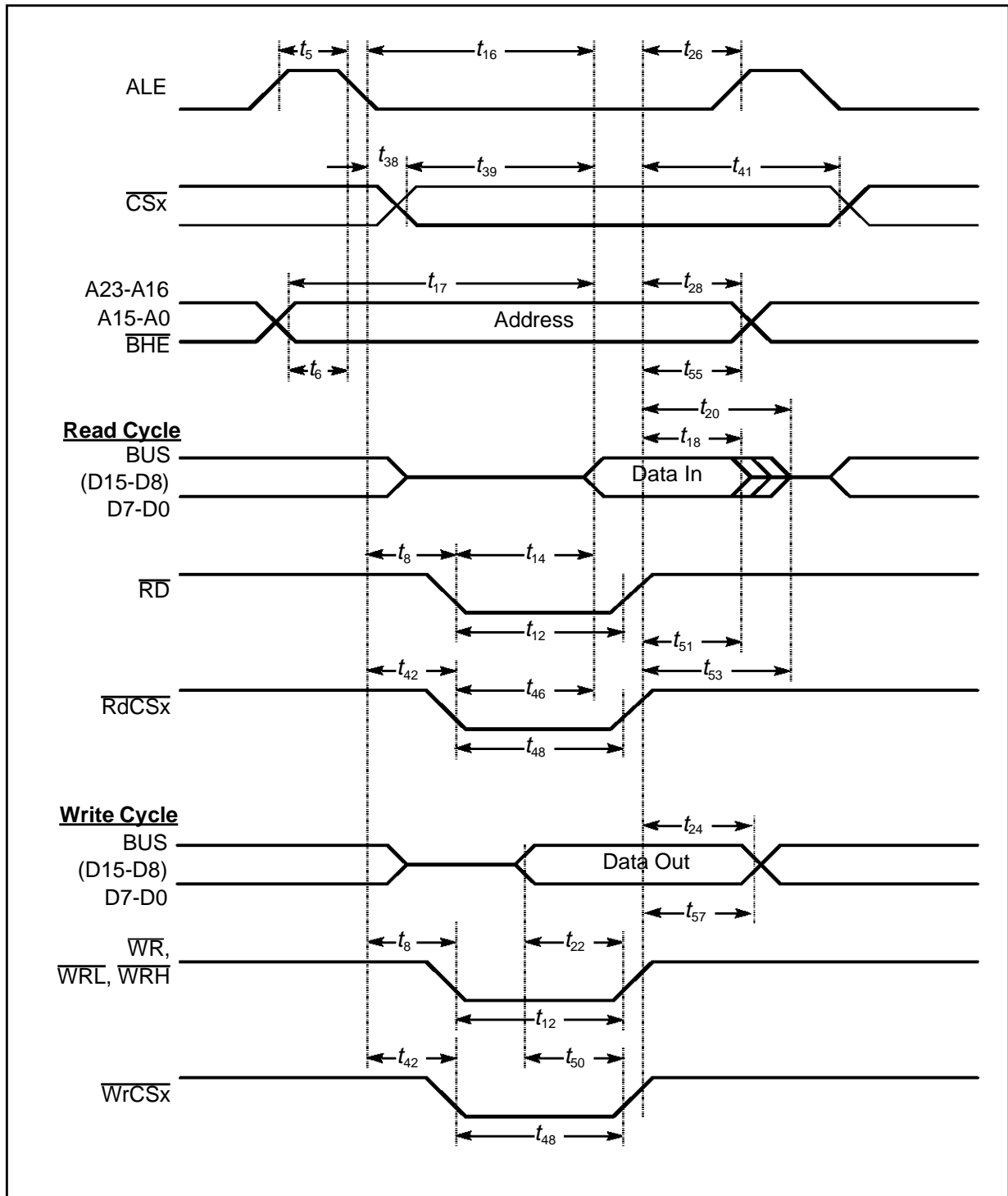

Figure 20.12 External Memory Cycle: Demultiplexed Bus, With Read/Write Delay, Extended ALE

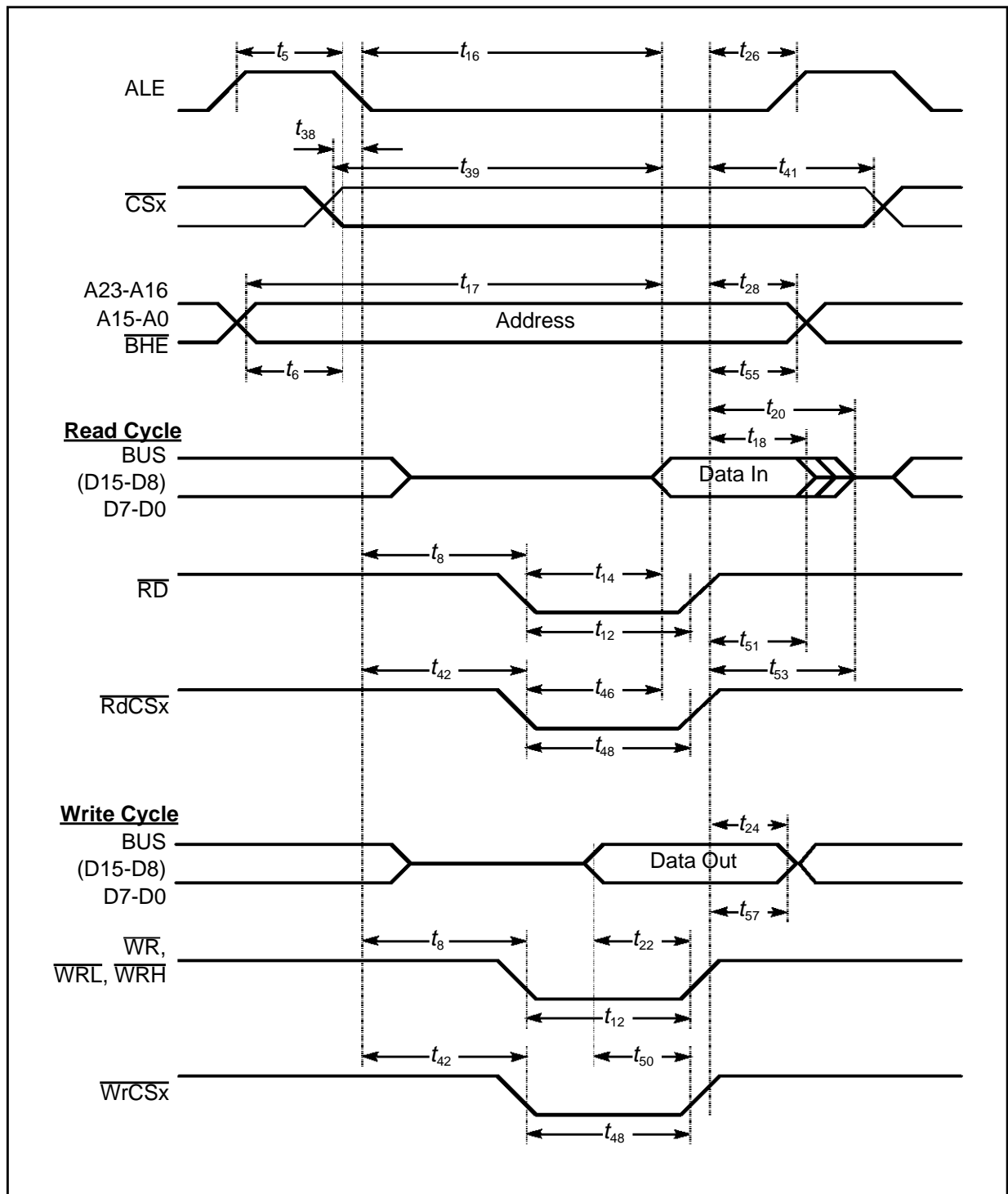

Figure 20.13 External Memory Cycle: Demultiplexed Bus, No Read/Write Delay, Normal ALE

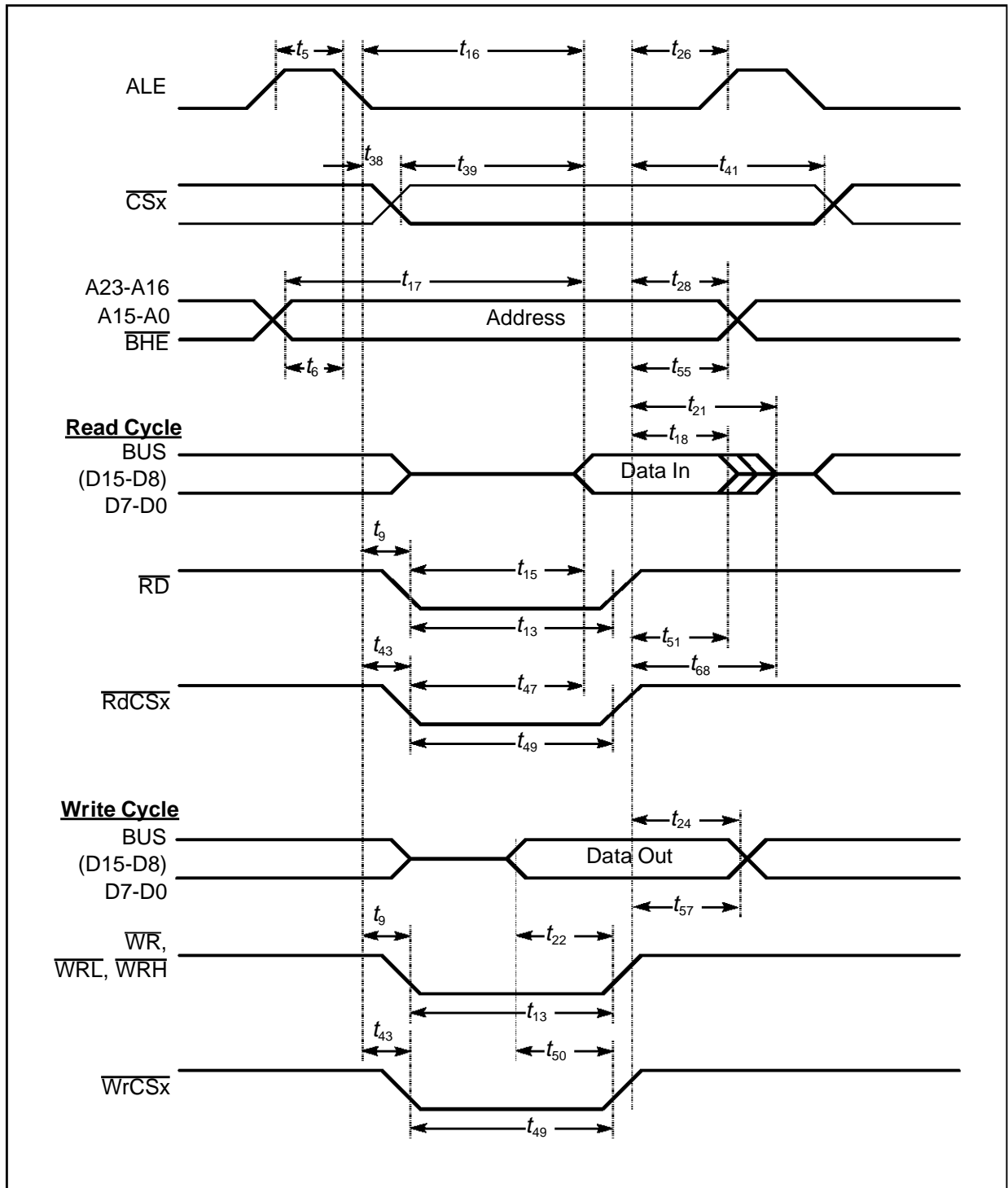
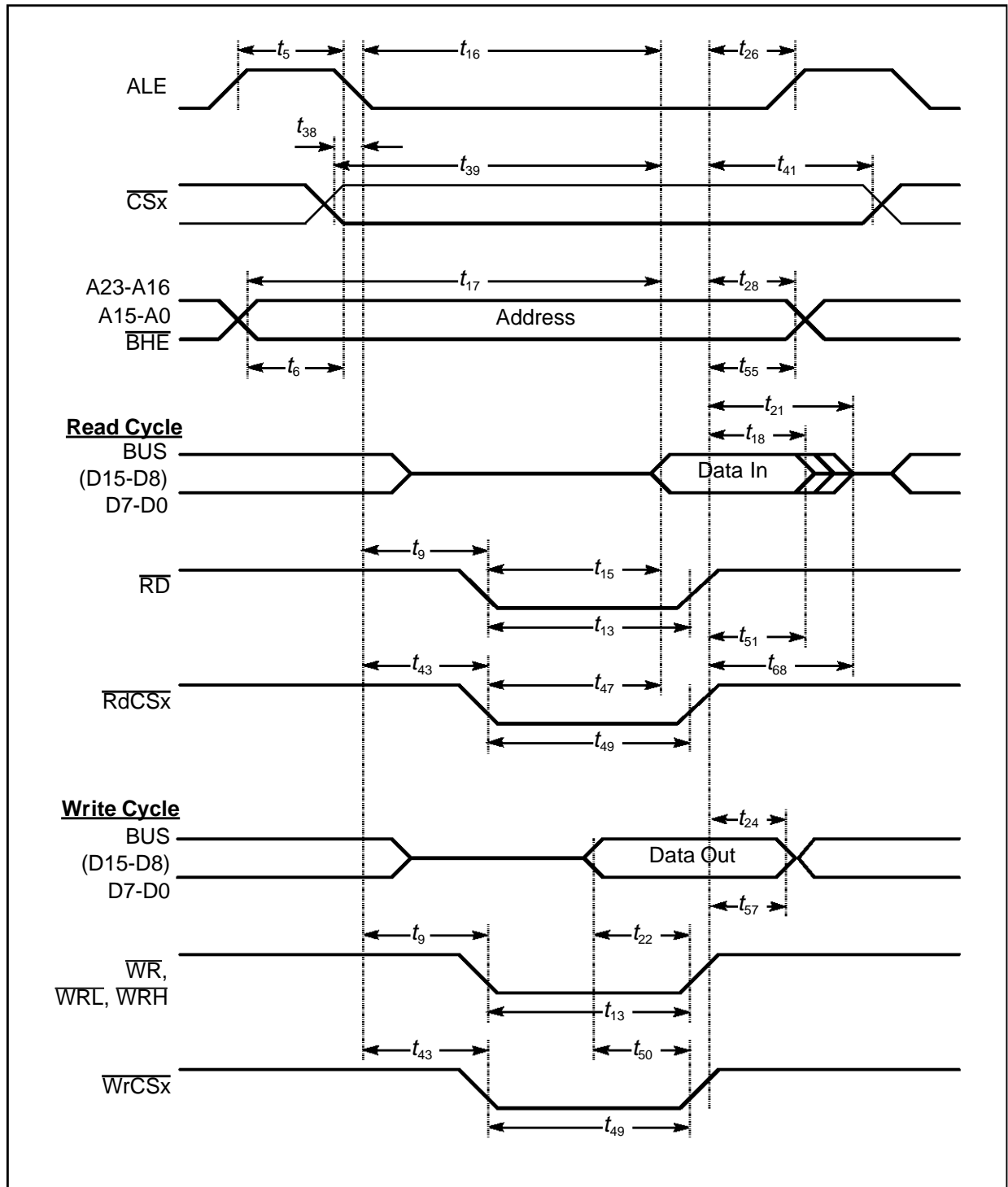

Figure 20.14 External Memory Cycle: Demultiplexed Bus, No Read/Write Delay, Extended ALE



20.5.9 CLKOUT and $\overline{\text{READY}}$

$V_{\text{DD}} = 5 \text{ V} \pm 5\%$, $V_{\text{SS}} = 0 \text{ V}$, $T_{\text{A}} = -40 \text{ to } +85 \text{ }^{\circ}\text{C}$

C_{L} (for PORT0, PORT1, Port 4, ALE, $\overline{\text{RD}}$, $\overline{\text{WR}}$, $\overline{\text{BHE}}$, CLKOUT) = 100 pF, C_{L} (for Port 6, $\overline{\text{CS}}$) = 100 pF

Table 20.8 CLKOUT and $\overline{\text{READY}}$ Characteristics

Parameter	Symbol	Max. CPU Clock = 20 MHz		Variable CPU Clock 1/2TCL = 1 to 20 MHz		Unit
		min.	max.	min.	max.	
CLKOUT cycle time	t_{29} CC	50	50	2TCL	2TCL	ns
CLKOUT high time	t_{30} CC	20	–	TCL – 5	–	ns
CLKOUT low time	t_{31} CC	15	–	TCL – 10	–	ns
CLKOUT rise time	t_{32} CC	–	5	–	5	ns
CLKOUT fall time	t_{33} CC	–	10	–	10	ns
CLKOUT rising edge to ALE falling edge	t_{34} CC	$-5 + t_{\text{A}}$	$10 + t_{\text{A}}$	$-5 + t_{\text{A}}$	$10 + t_{\text{A}}$	ns
Synchronous $\overline{\text{READY}}$ setup time to CLKOUT	t_{35} SR	30	–	30	–	ns
Synchronous $\overline{\text{READY}}$ hold time after CLKOUT	t_{36} SR	0	–	0	–	ns
Asynchronous $\overline{\text{READY}}$ low time	t_{37} SR	65	–	2TCL + 15	–	ns
Asynchronous $\overline{\text{READY}}$ setup time ¹⁾	t_{58} SR	15	–	15	–	ns
Asynchronous $\overline{\text{READY}}$ hold time ¹⁾	t_{59} SR	0	–	0	–	ns
Async. $\overline{\text{READY}}$ hold time after $\overline{\text{RD}}$, $\overline{\text{WR}}$ high (Demul- tiplexed Bus) ²⁾	t_{60} SR	0	$0 + t_{\text{c}}$ $+ 2t_{\text{A}} + t_{\text{F}}$ ²⁾	0	TCL - 25 $+ t_{\text{c}} + 2t_{\text{A}} + t_{\text{F}}$ ²⁾	ns

Notes 1: These timings are given for test purposes only, in order to assure recognition at a specific clock edge.

2: Demultiplexed bus is the worst case. For multiplexed bus 2TCL are to be added to the maximum values. This adds even more time for deactivating $\overline{\text{READY}}$.

The $2t_{\text{A}}$ and $2t_{\text{c}}$ refer to the next bus cycle, t_{F} refers to the current bus cycle.

Figure 20.15 CLKOUT and $\overline{\text{READY}}$

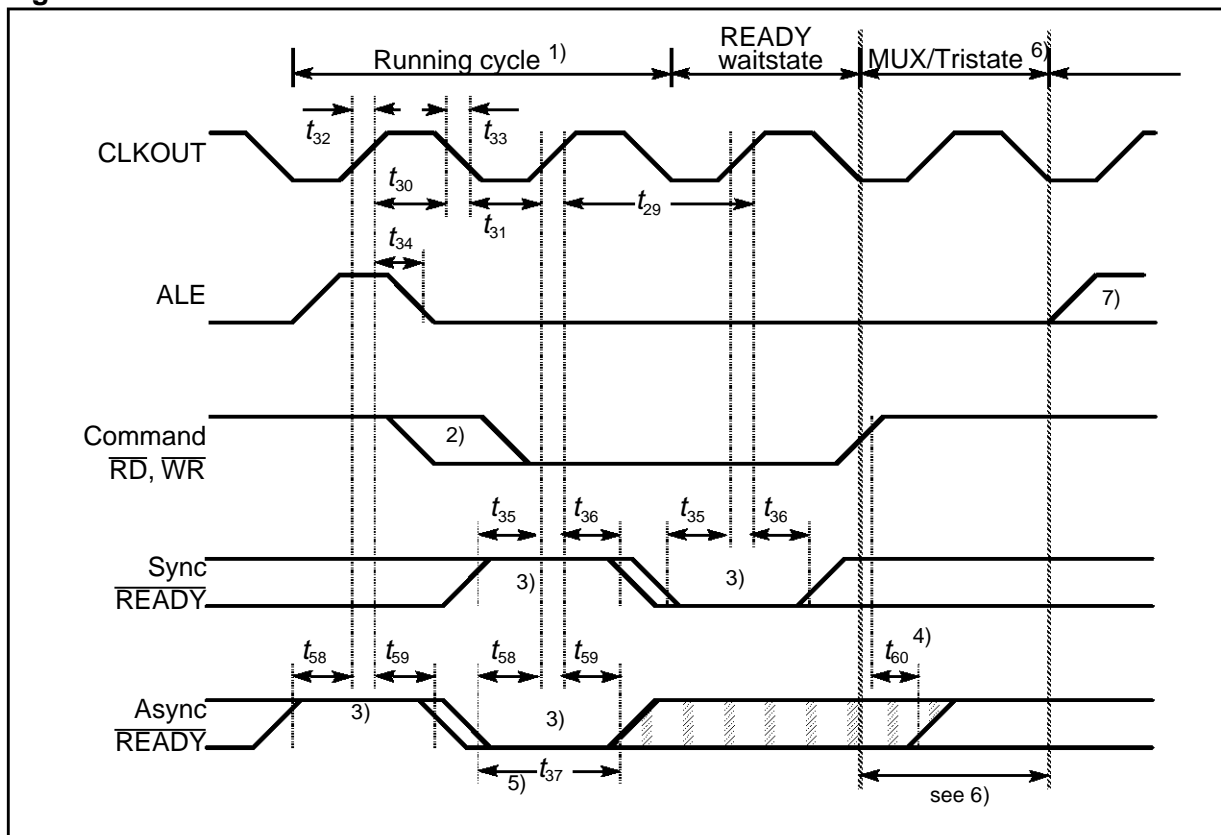

- Notes
- 1: Cycle as programmed, including MCTC waitstates (Example shows 0 MCTC WS).
 - 2: The leading edge of the respective command depends on RW-delay.
 - 3: $\overline{\text{READY}}$ sampled HIGH at this sampling point generates a $\overline{\text{READY}}$ controlled waitstate, $\overline{\text{READY}}$ sampled LOW at this sampling point terminates the currently running bus cycle.
 - 4: $\overline{\text{READY}}$ may be deactivated in response to the trailing (rising) edge of the corresponding command (RD or WR).
 - 5: If the Asynchronous $\overline{\text{READY}}$ signal does not fulfil the indicated setup and hold times with respect to CLKOUT (e.g. because CLKOUT is not enabled), it must fulfil t_{37} in order to be safely synchronized. This is guaranteed, if $\overline{\text{READY}}$ is removed in response to the command (see Note ⁴⁾).
 - 6: Multiplexed bus modes have a MUX waitstate added after a bus cycle, and an additional MTTC waitstate may be inserted here.
For a multiplexed bus with MTTC waitstate this delay is 2 CLKOUT cycles, for a demultiplexed bus without MTTC waitstate this delay is zero.
 - 7: The next external bus cycle may start here.

20.5.10 External Bus Arbitration

$V_{DD} = 5\text{ V} \pm 5\%$, $V_{SS} = 0\text{ V}$, $T_A = -40\text{ to }+85\text{ }^\circ\text{C}$

C_L (for PORT0, PORT1, Port 4, ALE, \overline{RD} , \overline{WR} , \overline{BHE} , CLKOUT) = 100 pF, C_L (for Port 6, \overline{CS}) = 100 pF

Table 20.9 External Bus Arbitration Characteristics

Parameter	Symbol	Max. CPU Clock = 20 MHz		Variable CPU Clock 1/2TCL = 1 to 20 MHz		Unit
		min.	max.	min.	max.	
HOLD input setup time to CLKOUT	t_{61} SR	35	–	35	–	ns
CLKOUT to \overline{HLDA} high or \overline{BREQ} low delay	t_{62} CC	–	20	–	20	ns
CLKOUT to \overline{HLDA} low or \overline{BREQ} high delay	t_{63} CC	–	20	–	20	ns
\overline{CSx} release	t_{64} CC	–	20	–	20	ns
\overline{CSx} drive	t_{65} CC	-5	25	-5	25	ns
Other signals release	t_{66} CC	–	20	–	20	ns
Other signals drive	t_{67} CC	-5	25	-5	25	ns

Figure 20.16 External Bus Arbitration, Releasing the Bus

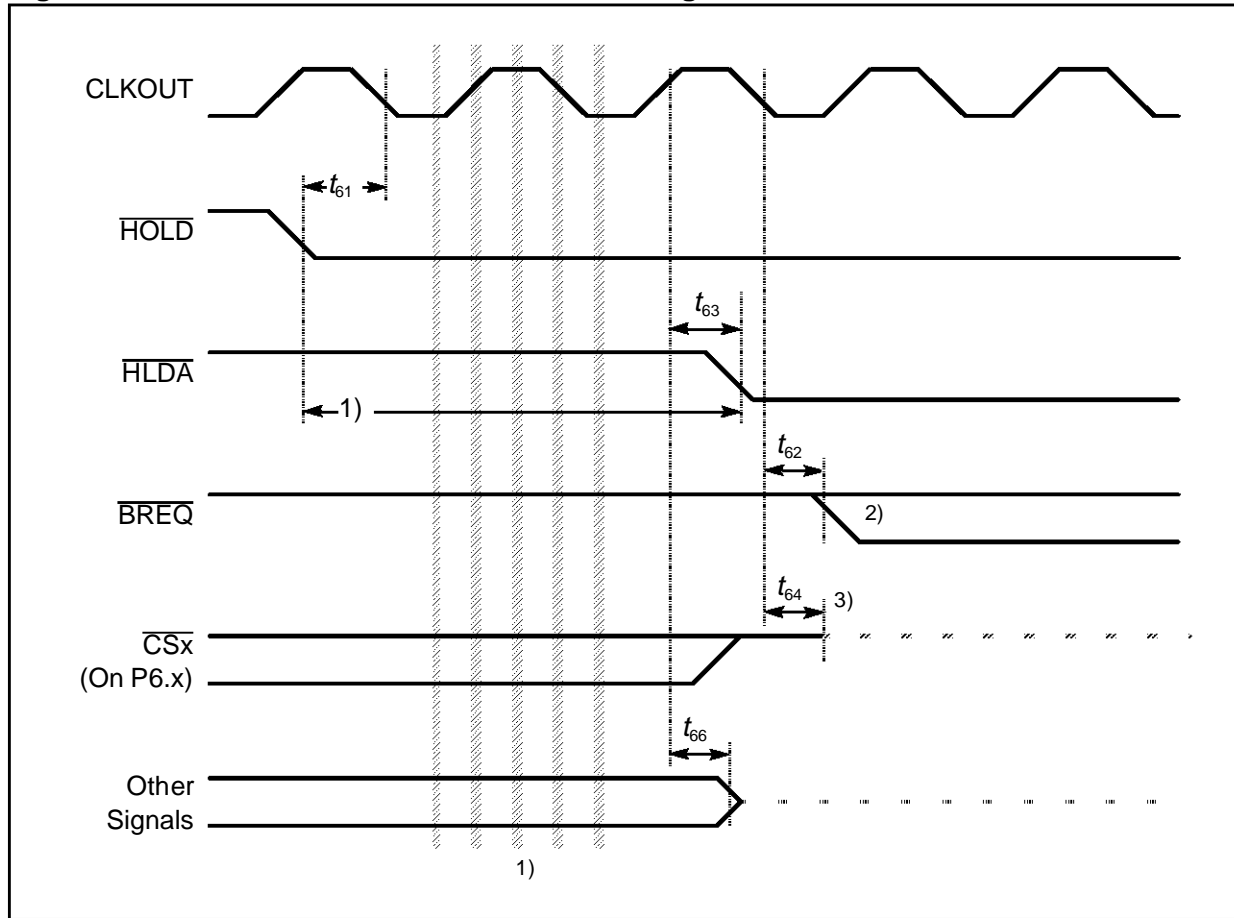

- Notes
- 1: The ST10F167 will complete the currently running bus cycle before granting bus access.
 - 2: This is the first possibility for $\overline{\text{BREQ}}$ to get active.
 - 3: The $\overline{\text{CS}}$ outputs will be resistive high (pullup) after t_{64} .

Figure 20.17 External Bus Arbitration (Regaining the Bus)

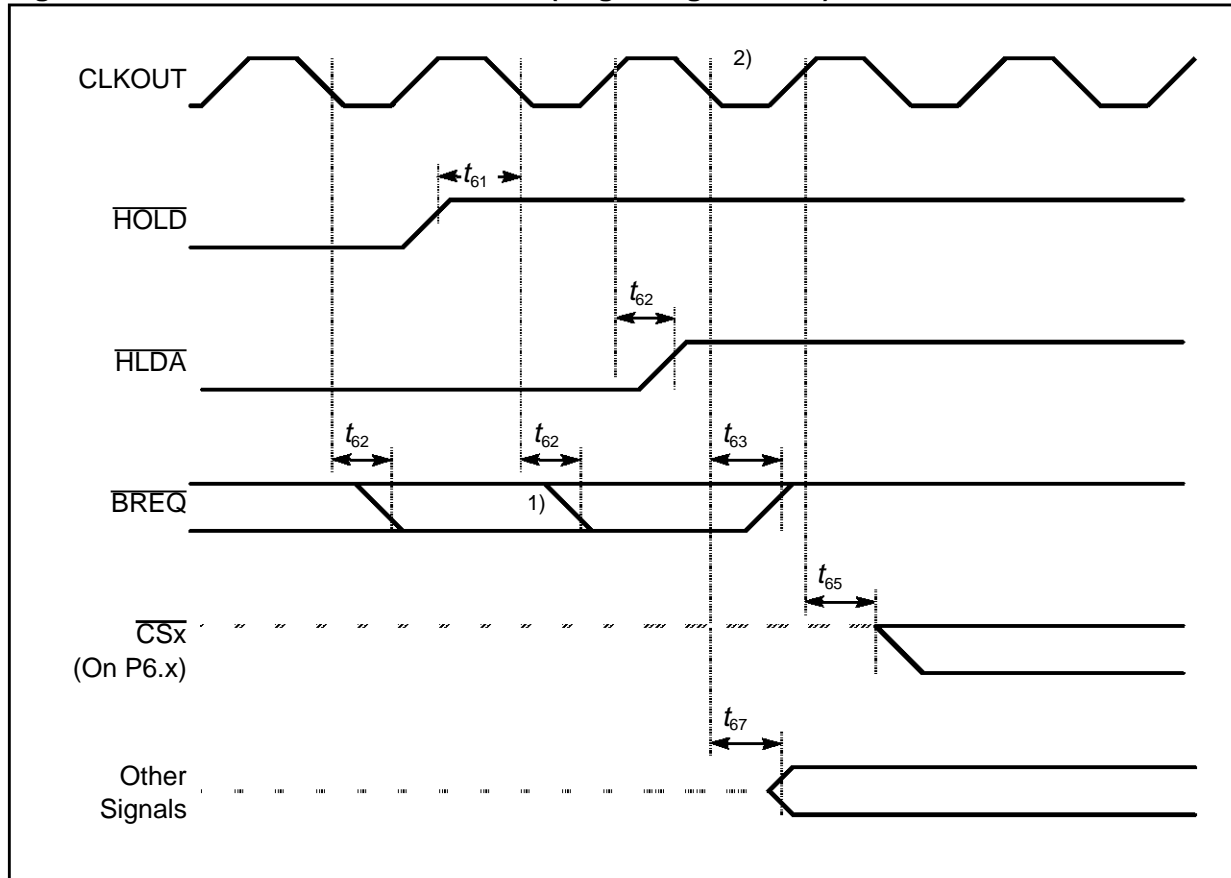

- Notes
- 1: This is the last chance for $\overline{\text{BREQ}}$ to trigger the indicated regain-sequence. Even if $\overline{\text{BREQ}}$ is activated earlier, the regain-sequence is initiated by $\overline{\text{HOLD}}$ going high. Please note that $\overline{\text{HOLD}}$ may also be deactivated without the ST10F167 requesting the bus.
 - 2: The next ST10F167 driven bus cycle may start here.

21 PACKAGE MECHANICAL DATA

Figure 21.1 Package Outline PQFP144 (28 x 28 mm)

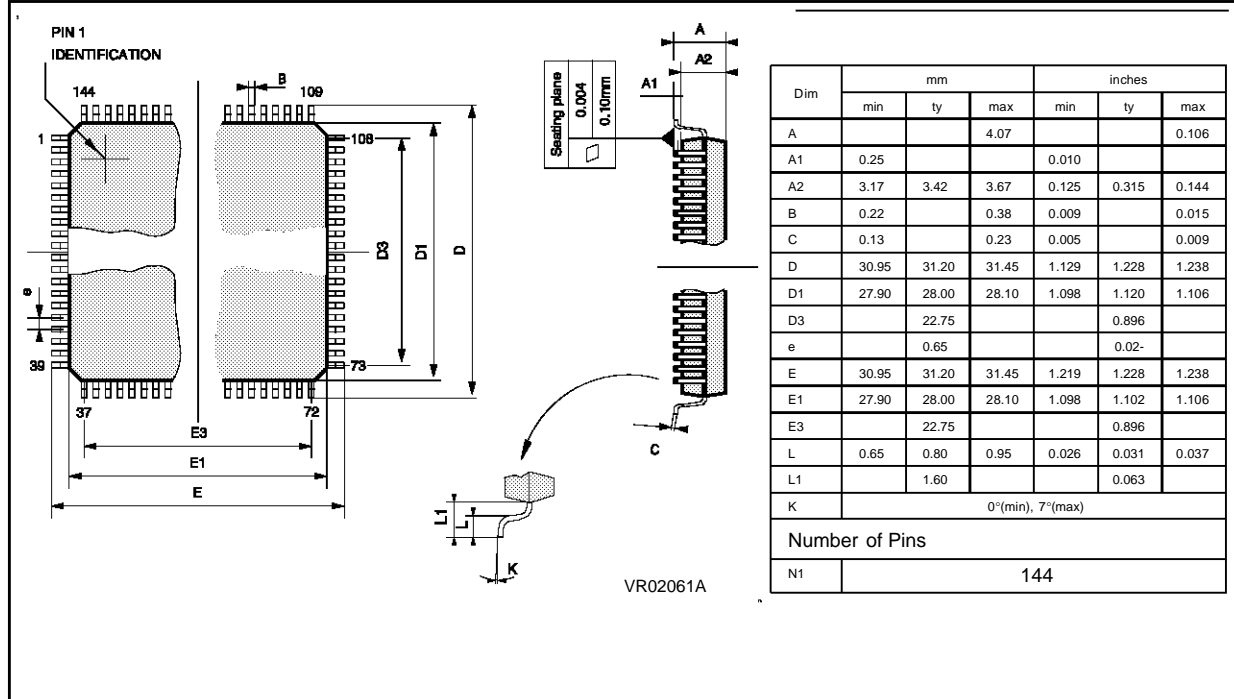

22 ORDERING INFORMATION

Salestype	Temperature range	Package
ST10F167-Q6	-40°C to 85°C	PQFP144 (28 x 28)

Information furnished is believed to be accurate and reliable. However, SGS-THOMSON Microelectronics assumes no responsibility for the consequences of use of such information nor for any infringement of patents or other rights of third parties which may result from its use. No license is granted by implication or otherwise under any patent or patent rights of SGS-THOMSON Microelectronics. Specifications mentioned in this publication are subject to change without notice. This publication supersedes and replaces all information previously supplied. SGS-THOMSON Microelectronics products are not authorized for use as critical components in life support devices or systems without the express written approval of SGS-THOMSON Microelectronics.

©1997 SGS-THOMSON Microelectronics - All rights reserved.

SGS-THOMSON Microelectronics Group of Companies

Australia - Brazil - Canada - China - France - Germany - Hong Kong - Italy - Japan - Korea - Malaysia - Malta - Morocco
The Netherlands - Singapore - Spain - Sweden - Switzerland - Taiwan - Thailand - United Kingdom - U.S.A.