

MSM5117400D

4,194,304-Word × 4-Bit DYNAMIC RAM : FAST PAGE MODE TYPE

DESCRIPTION

The MSM5117400D is a 4,194,304-word × 4-bit dynamic RAM fabricated in Oki's silicon-gate CMOS technology. The MSM5117400D achieves high integration, high-speed operation, and low-power consumption because Oki manufactures the device in a quadruple-layer polysilicon/double-layer metal CMOS process. The MSM5117400D is available in a 26/24-pin plastic SOJ, 26/24-pin plastic TSOP.

FEATURES

- 4,194,304-word × 4-bit configuration
 - Single 5V power supply, ±10% tolerance
 - Input : TTL compatible, low input capacitance
 - Output : TTL compatible, 3-state
 - Refresh : 2048 cycles/32 ms
 - Fast page mode, read modify write capability
 - $\overline{\text{CAS}}$ before $\overline{\text{RAS}}$ refresh, hidden refresh, $\overline{\text{RAS}}$ -only refresh capability
 - Multi-bit test mode capability
 - Package options:
 - 26/24-pin 300mil plastic SOJ (SOJ26/24-P-300-1.27) (Product : MSM5117400D-xxSJ)
 - 26/24-pin 300mil plastic TSOP (TSOPII26/24-P-300-1.27-K) (Product : MSM5117400D-xxTS-K)
- xx : indicates speed rank.

PRODUCT FAMILY

Family	Access Time (Max.)				Cycle Time (Min.)	Power Dissipation	
	t _{RAC}	t _{AA}	t _{CAC}	t _{OEA}		Operating (Max.)	Standby (Max.)
MSM5117400D-50	50ns	25ns	13ns	13ns	90ns	550mW	5.5mW
MSM5117400D-60	60ns	30ns	15ns	15ns	110ns	495mW	
MSM5117400D-70	70ns	35ns	20ns	20ns	130ns	440mW	

PIN CONFIGURATION (TOP VIEW)

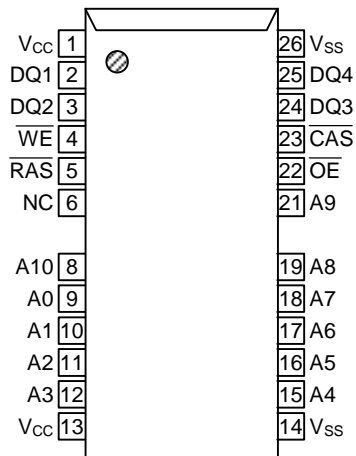

26/24-Pin Plastic SOJ

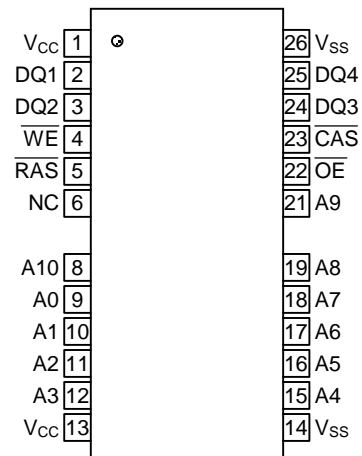
26/24-Pin Plastic TSOP
(K Type)

Pin Name	Function
A0–A10	Address Input
$\overline{\text{RAS}}$	Row Address Strobe
$\overline{\text{CAS}}$	Column Address Strobe
DQ1–DQ4	Data Input/Data Output
$\overline{\text{OE}}$	Output Enable
$\overline{\text{WE}}$	Write Enable
V _{CC}	Power Supply (5V)
V _{SS}	Ground (0V)
NC	No Connection

BLOCK DIAGRAM

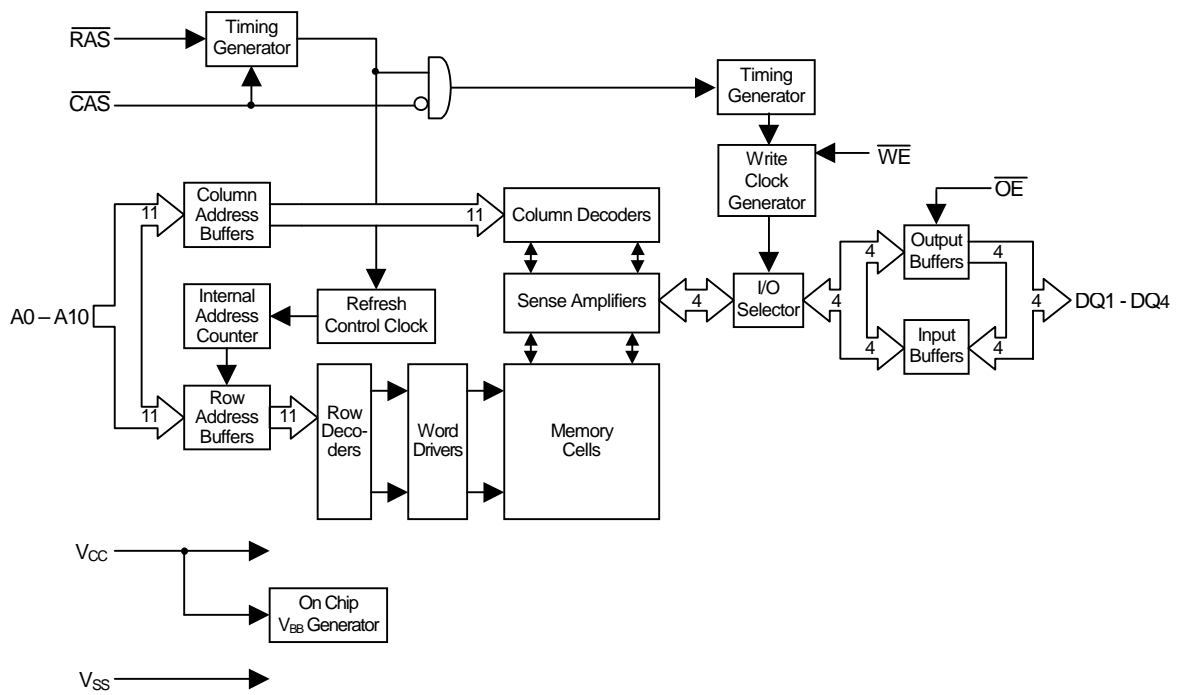

ELECTRICAL CHARACTERISTICS

Absolute Maximum Ratings

Parameter	Symbol	Rating	Unit
Voltage on Any Pin Relative to V_{SS}	V_{IN}, V_{OUT}	-0.5 to $V_{CC} + 0.5$	V
Voltage V_{CC} supply Relative to V_{SS}	V_{CC}	0.5 to 7.0	V
Short Circuit Output Current	I_{OS}	50	mA
Power Dissipation	P_D^*	1	W
Operating Temperature	T_{opr}	0 to 70	°C
Storage Temperature	T_{stg}	-55 to 150	°C

*: $T_a = 25^\circ\text{C}$

Recommended Operating Conditions

 $(T_a = 0^\circ\text{C to } 70^\circ\text{C})$

Parameter	Symbol	Min.	Typ.	Max.	Unit
Power Supply Voltage	V_{CC}	4.5	5.0	5.5	V
	V_{SS}	0	0	0	V
Input High Voltage	V_{IH}	2.4	—	$V_{CC} + 0.5^{*1}$	V
Input Low Voltage	V_{IL}	-0.5^{*2}	—	0.8	V

Notes: *1. The input voltage is $V_{CC} + 2.0\text{V}$ when the pulse width is less than 20ns (the pulse width is with respect to the point at which V_{CC} is applied).

*2. The input voltage is $V_{SS} - 2.0\text{V}$ when the pulse width is less than 20ns (the pulse width respect to the point at which V_{SS} is applied).

Capacitance

 $(V_{CC} = 5\text{V} \pm 10\%, T_a = 25^\circ\text{C}, f=1\text{MHz})$

Parameter	Symbol	Typ.	Max.	Unit
Input Capacitance (A0 – A10)	C_{IN1}	—	5	pF
Input Capacitance ($\overline{\text{RAS}}$, $\overline{\text{CAS}}$, $\overline{\text{WE}}$, $\overline{\text{OE}}$)	C_{IN2}	—	7	pF
Output Capacitance (DQ1 – DQ4)	$C_{I/O}$	—	7	pF

DC Characteristics

 $(V_{CC} = 5V \pm 10\%, T_a = 0^\circ C \text{ to } 70^\circ C)$

Parameter	Symbol	Condition	MSM5117400 D-50		MSM5117400 D-60		MSM5117400 D-70		Unit	Note
			Min.	Max	Min.	Max	Min.	Max		
Output High Voltage	V_{OH}	$I_{OH} = -5.0mA$	2.4	V_{CC}	2.4	V_{CC}	2.4	V_{CC}	V	
Output Low Voltage	V_{OL}	$I_{OL} = 4.2mA$	0	0.4	0	0.4	0	0.4	V	
Input Leakage Current	I_{LI}	$0V \leq V_I \leq 6.5V$; All other pins not under test = 0V	-10	10	-10	10	-10	10	μA	
Output Leakage Current	I_{LO}	DQ disable $0V \leq V_O \leq V_{CC}$	-10	10	-10	10	-10	10	μA	
Average Power Supply Current (Operating)	I_{CC1}	\overline{RAS} , \overline{CAS} cycling, $t_{RC} = \text{Min.}$	—	100	—	90	—	80	mA	1,2
Power Supply Current (Standby)	I_{CC2}	\overline{RAS} , $\overline{CAS} = V_{IH}$	—	2	—	2	—	2	mA	1
		\overline{RAS} , $\overline{CAS} \geq V_{CC} - 0.2V$	—	1	—	1	—	1		
Average Power Supply Current (\overline{RAS} -only Refresh)	I_{CC3}	\overline{RAS} cycling, $\overline{CAS} = V_{IH}$, $t_{RC} = \text{Min.}$	—	100	—	90	—	80	mA	1,2
Power Supply Current (Standby)	I_{CC5}	$\overline{RAS} = V_{IH}$, $\overline{CAS} = V_{IL}$, DQ = enable	—	5	—	5	—	5	mA	1
Average Power Supply Current (\overline{CAS} before \overline{RAS} Refresh)	I_{CC6}	$\overline{RAS} = \text{cycling}$, \overline{CAS} before \overline{RAS}	—	100	—	90	—	80	mA	1,2
Average Power Supply Current (Fast Page Mode)	I_{CC7}	$\overline{RAS} = V_{IL}$, \overline{CAS} cycling, $t_{PC} = \text{Min.}$	—	80	—	70	—	60	mA	1,3

- Notes: 1. I_{CC} Max. is specified as I_{CC} for output open condition.
 2. The address can be changed once or less while $\overline{RAS} = V_{IL}$.
 3. The address can be changed once or less while $\overline{CAS} = V_{IH}$.

AC Characteristic (1/2)

(V_{CC} = 5V ± 10%, Ta = 0°C to 70°C) Note1,2,3

Parameter	Symbol	MSM5117400 D-50		MSM5117400 D-60		MSM5117400 D-70		Unit	Note
		Min.	Max.	Min.	Max.	Min.	Max.		
Random Read or Write Cycle Time	t _{RC}	90	—	110	—	130	—	ns	
Read Modify Write Cycle Time	t _{RWC}	131	—	155	—	185	—	ns	
Fast Page Mode Cycle Time	t _{PC}	35	—	40	—	45	—	ns	
Fast Page Mode Read Modify Write Cycle Time	t _{PRWC}	76	—	85	—	100	—	ns	
Access Time from $\overline{\text{RAS}}$	t _{RAC}	—	50	—	60	—	70	ns	4,5,6
Access Time from $\overline{\text{CAS}}$	t _{CAC}	—	13	—	15	—	20	ns	4,5
Access Time from Column Address	t _{AA}	—	25	—	30	—	35	ns	4,6
Access Time from $\overline{\text{CAS}}$ Precharge	t _{CPA}	—	30	—	35	—	40	ns	4
Access Time from $\overline{\text{OE}}$	t _{OE A}	—	13	—	15	—	20	ns	4
Output Low Impedance Time from $\overline{\text{CAS}}$	t _{CLZ}	0	—	0	—	0	—	ns	4
$\overline{\text{CAS}}$ to Data Output Buffer Turn-off Delay Time	t _{OFF}	0	13	0	15	0	20	ns	7
$\overline{\text{OE}}$ to Data Output Buffer Turn-off Delay Time	t _{OEZ}	0	13	0	15	0	20	ns	7
Transition Time	t _T	3	50	3	50	3	50	ns	3
Refresh Period	t _{REF}	—	32	—	32	—	32	m	
$\overline{\text{RAS}}$ Precharge Time	t _{RP}	30	—	40	—	50	—	ns	
$\overline{\text{RAS}}$ Pulse Width	t _{RAS}	50	10,000	60	10,000	70	10,000	ns	
$\overline{\text{RAS}}$ Pulse Width (Fast Page Mode)	t _{RASP}	50	100,000	60	100,000	70	100,000	ns	
$\overline{\text{RAS}}$ Hold Time	t _{RSH}	13	—	15	—	20	—	ns	
$\overline{\text{RAS}}$ Hold Time referenced to $\overline{\text{OE}}$	t _{ROH}	13	—	15	—	20	—	ns	
$\overline{\text{CAS}}$ Precharge Time (Fast Page Mode)	t _{CP}	7	—	10	—	10	—	ns	
$\overline{\text{CAS}}$ Pulse Width	t _{CAS}	13	10,000	15	10,000	20	10,000	ns	
$\overline{\text{CAS}}$ Hold Time	t _{CSH}	50	—	60	—	70	—	ns	
$\overline{\text{CAS}}$ to $\overline{\text{RAS}}$ Precharge Time	t _{CRP}	5	—	5	—	5	—	ns	
$\overline{\text{RAS}}$ Hold Time from $\overline{\text{CAS}}$ Precharge	t _{RHCP}	30	—	35	—	40	—	ns	
$\overline{\text{RAS}}$ to $\overline{\text{CAS}}$ Delay Time	t _{RCD}	17	37	20	45	20	50	ns	5
$\overline{\text{RAS}}$ to Column Address Delay Time	t _{RAD}	12	25	15	30	15	35	ns	
Row Address Set-up Time	t _{ASR}	0	—	0	—	0	—	ns	
Row Address Hold Time	t _{RAH}	7	—	10	—	10	—	ns	
Column Address Set-up Time	t _{ASC}	0	—	0	—	0	—	ns	

AC Characteristic (2/2)

(V_{CC} = 5V ± 10%, T_a = 0°C to 70°C) Note1,2,3

Parameter	Symbol	MSM5117400 D-50		MSM5117400 D-60		MSM5117400 D-70		Unit	Note
		Min.	Max.	Min.	Max.	Min.	Max.		
Column Address Hold Time	t _{CAH}	7	—	10	—	15	—	ns	
Column Address to $\overline{\text{RAS}}$ Lead Time	t _{RAL}	25	—	30	—	35	—	ns	
Read Command Set-up Time	t _{RCS}	0	—	0	—	0	—	ns	
Read Command Hold Time	t _{RCH}	0	—	0	—	0	—	ns	8
Read Command Hold Time referenced to $\overline{\text{RAS}}$	t _{RRH}	0	—	0	—	0	—	ns	8
Write Command Set-up Time	t _{WCS}	0	—	0	—	0	—	ns	9
Write Command Hold Time	t _{WCH}	7	—	10	—	15	—	ns	
Write Command Pulse Width	t _{WP}	7	—	10	—	10	—	ns	
$\overline{\text{OE}}$ Command Hold Time	t _{OEH}	13	—	15	—	20	—	ns	
Write Command to $\overline{\text{RAS}}$ Lead Time	t _{RWL}	13	—	15	—	20	—	ns	
Write Command to $\overline{\text{CAS}}$ Lead Time	t _{CWL}	13	—	15	—	20	—	ns	
Data-in Set-up Time	t _{DS}	0	—	0	—	0	—	ns	10
Data-in Hold Time	t _{DH}	7	—	10	—	15	—	ns	10
$\overline{\text{OE}}$ to Data-in Delay Time	t _{OED}	13	—	15	—	20	—	ns	
$\overline{\text{CAS}}$ to $\overline{\text{WE}}$ Delay Time	t _{CWD}	36	—	40	—	50	—	ns	9
Column Address to $\overline{\text{WE}}$ Delay Time	t _{AWD}	48	—	55	—	65	—	ns	9
$\overline{\text{RAS}}$ to $\overline{\text{WE}}$ Delay Time	t _{RWD}	73	—	85	—	100	—	ns	9
$\overline{\text{CAS}}$ Precharge $\overline{\text{WE}}$ Delay Time	t _{CPWD}	53	—	60	—	70	—	ns	9
$\overline{\text{CAS}}$ Active Delay Time from $\overline{\text{RAS}}$ Precharge	t _{RPC}	5	—	5	—	5	—	ns	
$\overline{\text{RAS}}$ to $\overline{\text{CAS}}$ Set-up Time ($\overline{\text{CAS}}$ before $\overline{\text{RAS}}$)	t _{CSR}	10	—	10	—	10	—	ns	
$\overline{\text{RAS}}$ to $\overline{\text{CAS}}$ Hold Time ($\overline{\text{CAS}}$ before $\overline{\text{RAS}}$)	t _{CHR}	10	—	10	—	10	—	ns	
$\overline{\text{WE}}$ to $\overline{\text{RAS}}$ Precharge Time ($\overline{\text{CAS}}$ before $\overline{\text{RAS}}$)	t _{WRP}	10	—	10	—	10	—	ns	
$\overline{\text{WE}}$ Hold Time from $\overline{\text{RAS}}$ ($\overline{\text{CAS}}$ before $\overline{\text{RAS}}$)	t _{WRH}	10	—	10	—	10	—	ns	
$\overline{\text{RAS}}$ to $\overline{\text{WE}}$ Set-up Time (Test Mode)	t _{WTS}	10	—	10	—	10	—	ns	
$\overline{\text{RAS}}$ to $\overline{\text{WE}}$ Hold Time (Test Mode)	t _{WTH}	10	—	10	—	10	—	ns	

- Notes:
1. A start-up delay of 200 μ s is required after power-up, followed by a minimum of eight initialization cycles ($\overline{\text{RAS}}$ -only refresh or $\overline{\text{CAS}}$ before $\overline{\text{RAS}}$ refresh) before proper device operation is achieved.
 2. The AC characteristics assume $t_T = 5\text{ns}$.
 3. V_{IH} (Min.) and V_{IL} (Max.) are reference levels for measuring input timing signals. Transition times (t_T) are measured between V_{IH} and V_{IL} .
 4. This parameter is measured with a load circuit equivalent to 2 TTL load and 100pF.
 5. Operation within the t_{RCD} (Max.) limit ensures that t_{RAC} (Max.) can be met. t_{RCD} (Max.) is specified as a reference point only. If t_{RCD} is greater than the specified t_{RCD} (Max.) limit, then the access time is controlled by t_{CAC} .
 6. Operation within the t_{RAD} (Max.) limit ensures that t_{RAC} (Max.) can be met. t_{RAD} (Max.) is specified as a reference point only. If t_{RAD} is greater than the specified t_{RAD} (Max.) limit, then the access time is controlled by t_{AA} .
 7. t_{OFF} (Max.) and t_{OEZ} (Max.) define the time at which the output achieved the open circuit condition and are not referenced to output voltage levels.
 8. t_{RCH} or t_{RRH} must be satisfied for a read cycle.
 9. t_{WCS} , t_{CWD} , t_{RWD} , t_{AWD} and t_{CPWD} are not restrictive operating parameters. They are included in the data sheet as electrical characteristics only. If $t_{WCS} \geq t_{WCS}$ (Min.), then the cycle is an early write cycle and the data out will remain open circuit (high impedance) throughout the entire cycle. If $t_{CWD} \geq t_{CWD}$ (Min.), $t_{RWD} \geq t_{RWD}$ (Min.), $t_{AWD} \geq t_{AWD}$ (Min.) and $t_{CPWD} \geq t_{CPWD}$ (Min.), then the cycle is a read modify write cycle and data out will contain data read from the selected cell; if neither of the above sets of conditions is satisfied, then the condition of the data out (at access time) is indeterminate.
 10. These parameters are referenced to the $\overline{\text{CAS}}$ leading edge in an early write cycle, and to the $\overline{\text{WE}}$ leading edge in an $\overline{\text{OE}}$ control write cycle, or a read modify write cycle.
 11. The test mode is initiated by performing a $\overline{\text{WE}}$ and $\overline{\text{CAS}}$ before $\overline{\text{RAS}}$ refresh cycle. This mode is latched and remains in effect until the exit cycle is generated. In a test mode CA0 and CA1 are not used and each DQ pin now accesses 4-bit locations. Since all 4DQ pins are used, a total of 16 data bits can be written in parallel into the memory array. In a read cycle, if 4 data bits are equal, the DQ pin will indicate a high level. If the 4 data bits are not equal, the DQ pin will indicate a low level. The test mode is cleared and the memory device returned to its normal operating state by performing a $\overline{\text{RAS}}$ -only refresh cycle or a $\overline{\text{CAS}}$ before $\overline{\text{RAS}}$ refresh cycle.
 12. In a test mode read cycle, the value of access time parameters is delayed for 5ns for the specified value. These parameters should be specified in test mode cycle by adding the above value to the specified value in this data sheet.

Timing Chart

• Read Cycle

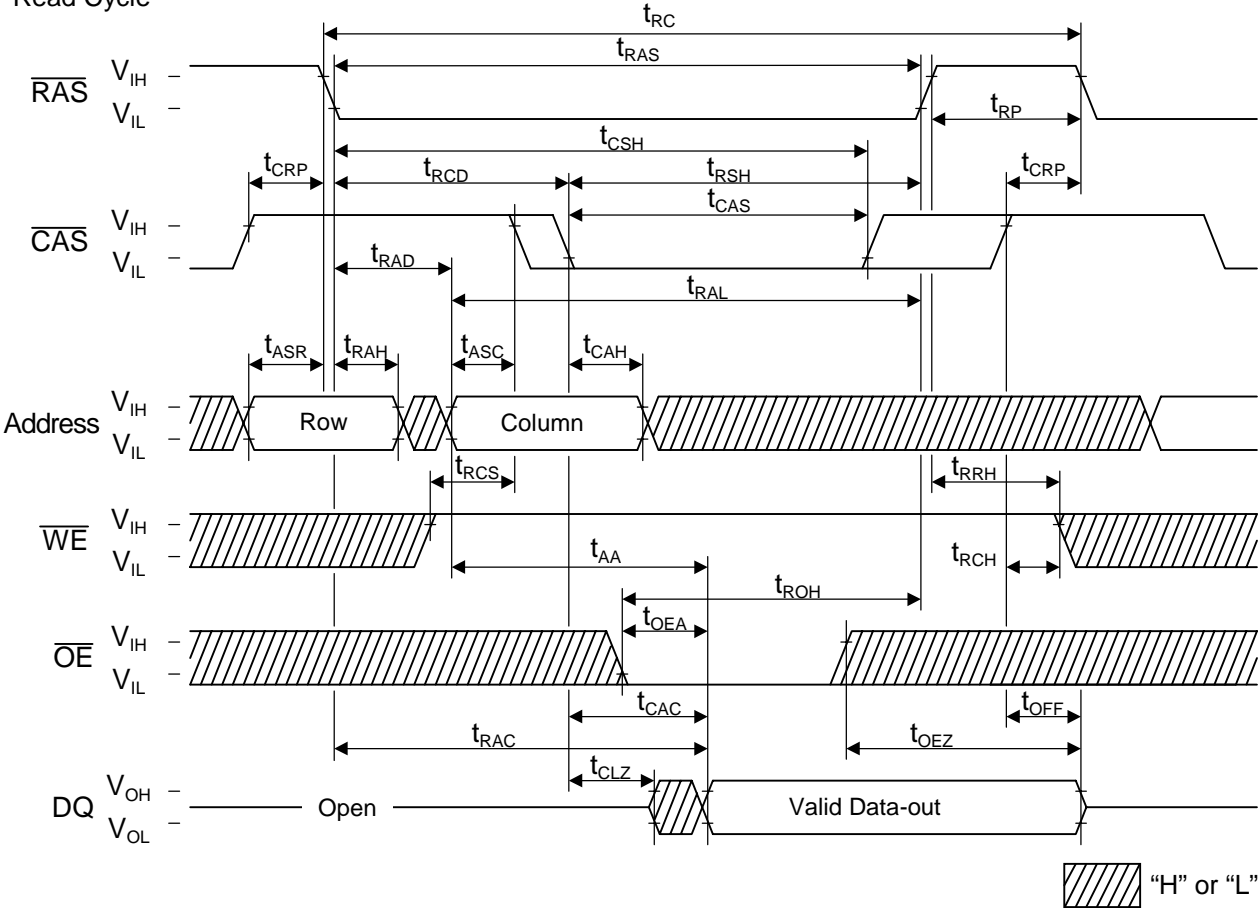

• Write Cycle (Early Write)

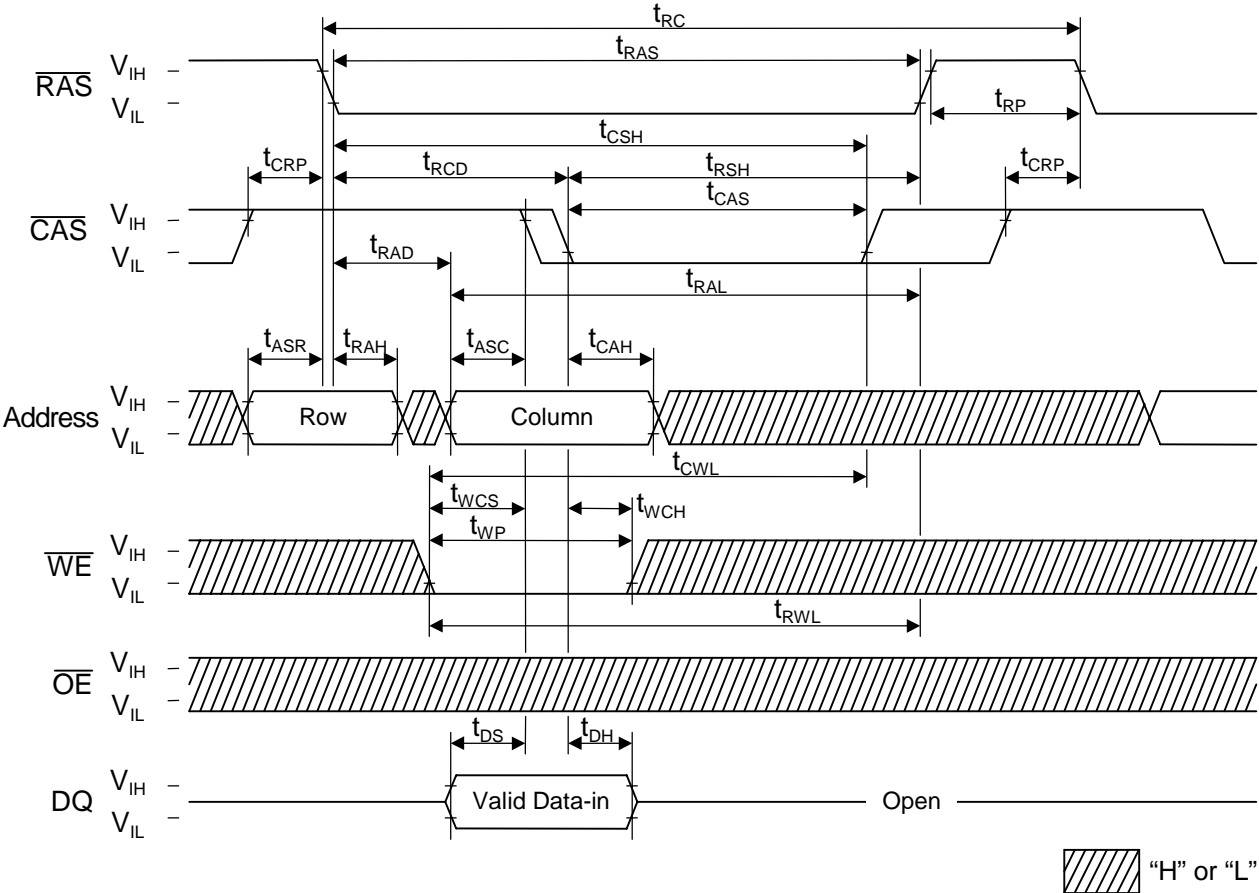

• Read Modify Write Cycle

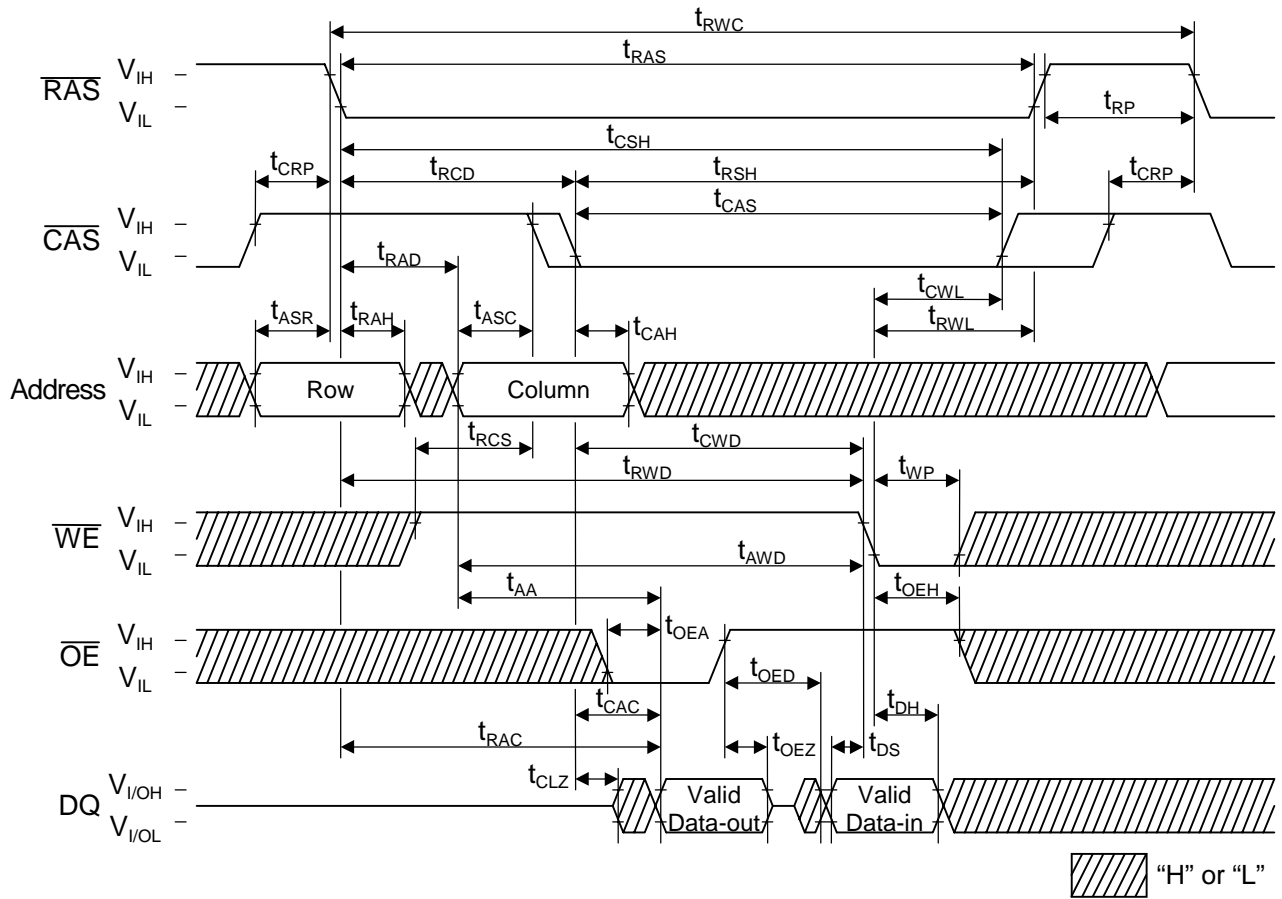

- Fast Page Mode Cycle

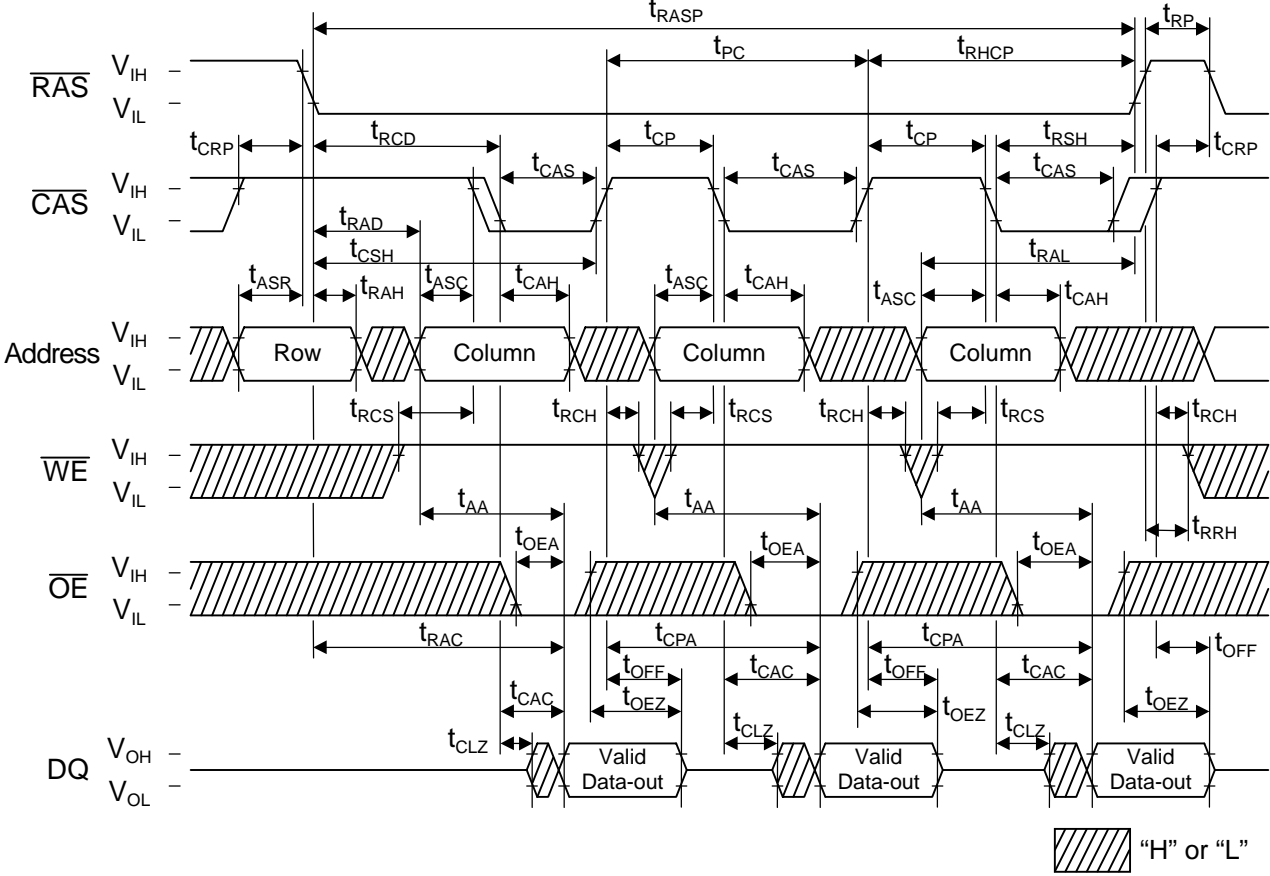

- Fast Page Mode Write Cycle (Early Write)

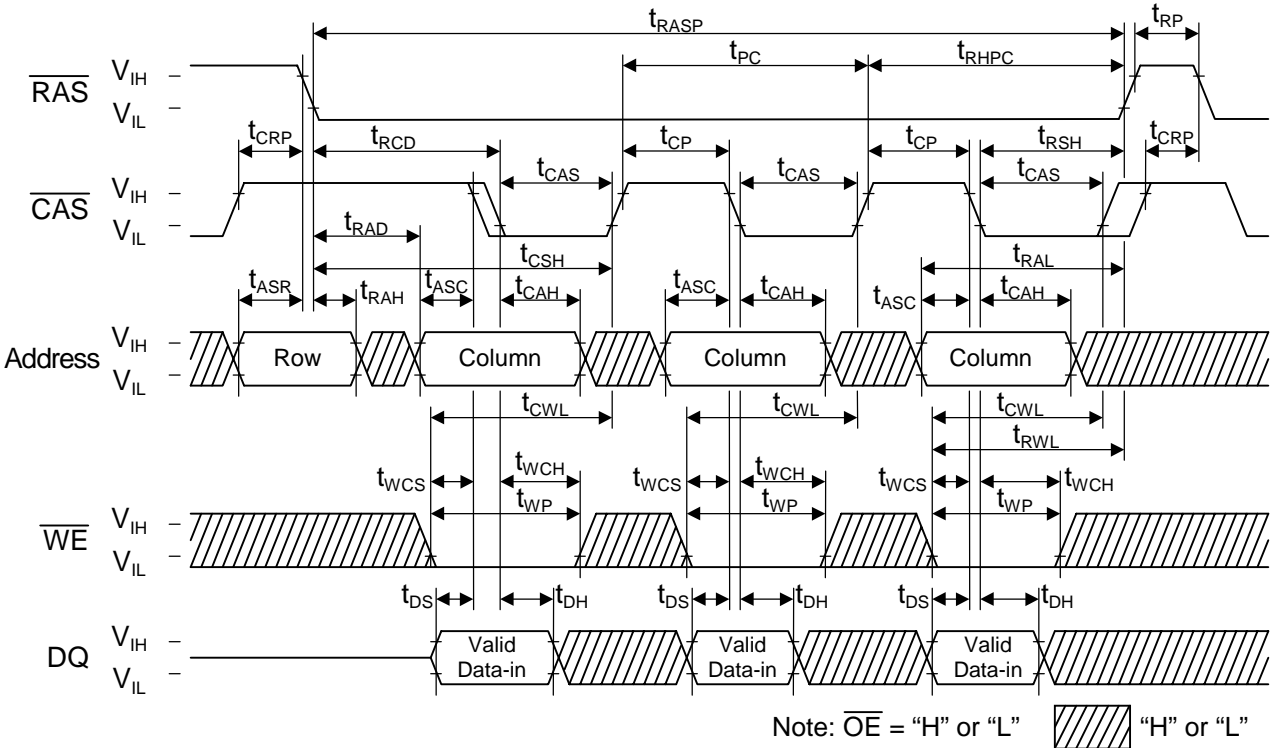

• Fast Page Mode Read Modify Write Cycle

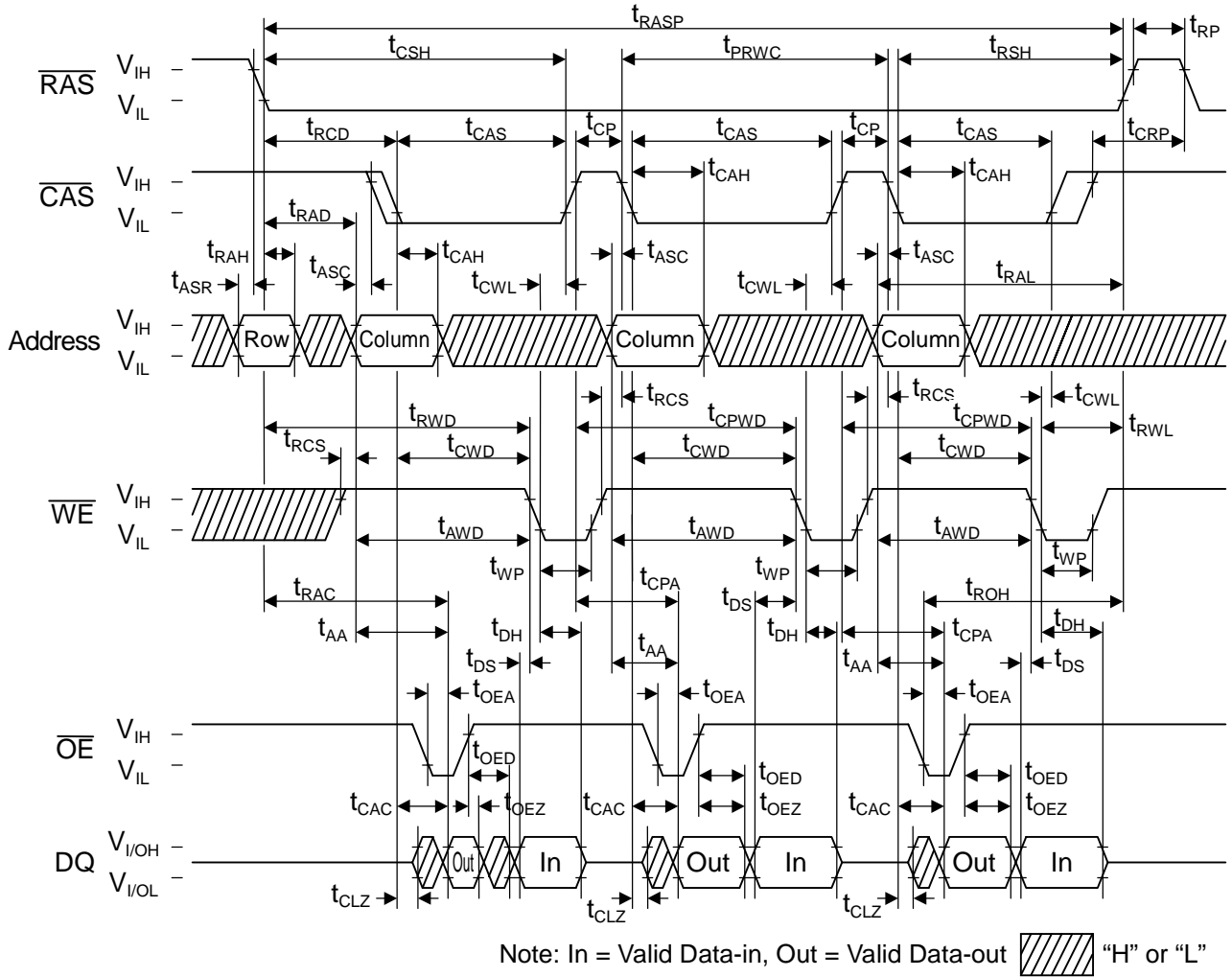

• RAS-only Refresh Cycle

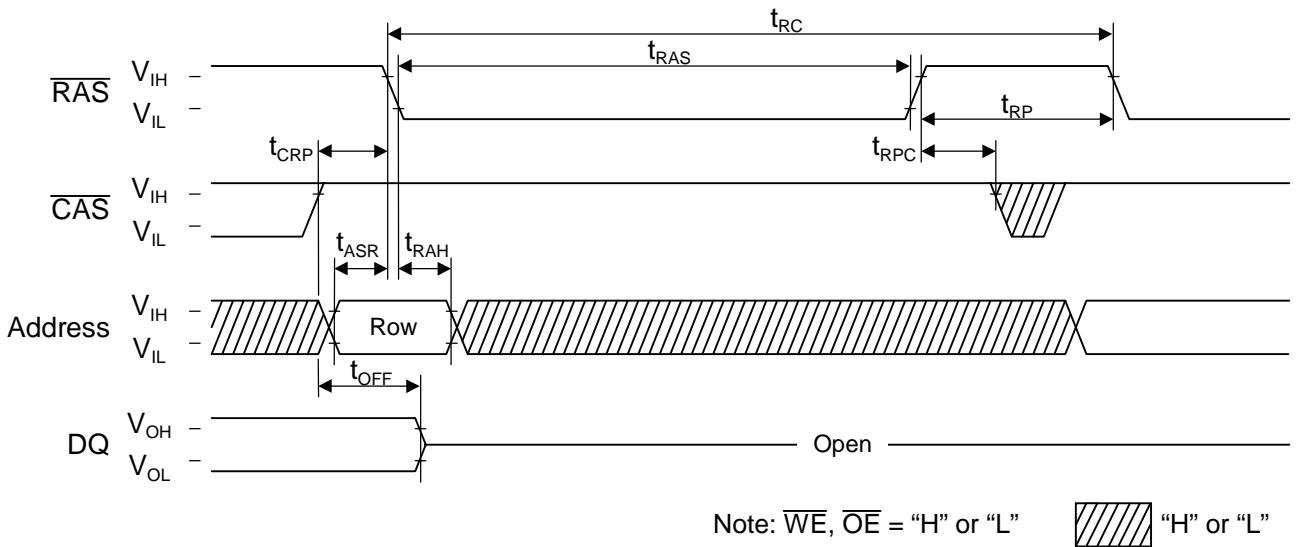

• $\overline{\text{CAS}}$ before $\overline{\text{RAS}}$ Refresh Cycle

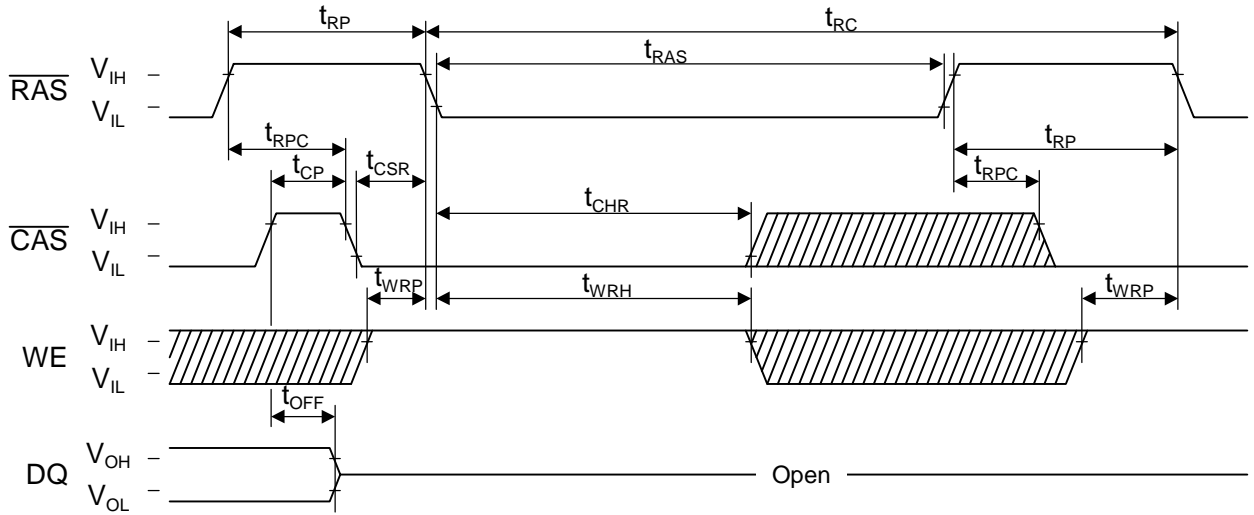

Note: $\overline{\text{WE}}$, $\overline{\text{OE}}$, Address = "H" or "L"  "H" or "L"

• Hidden Refresh Read Cycle

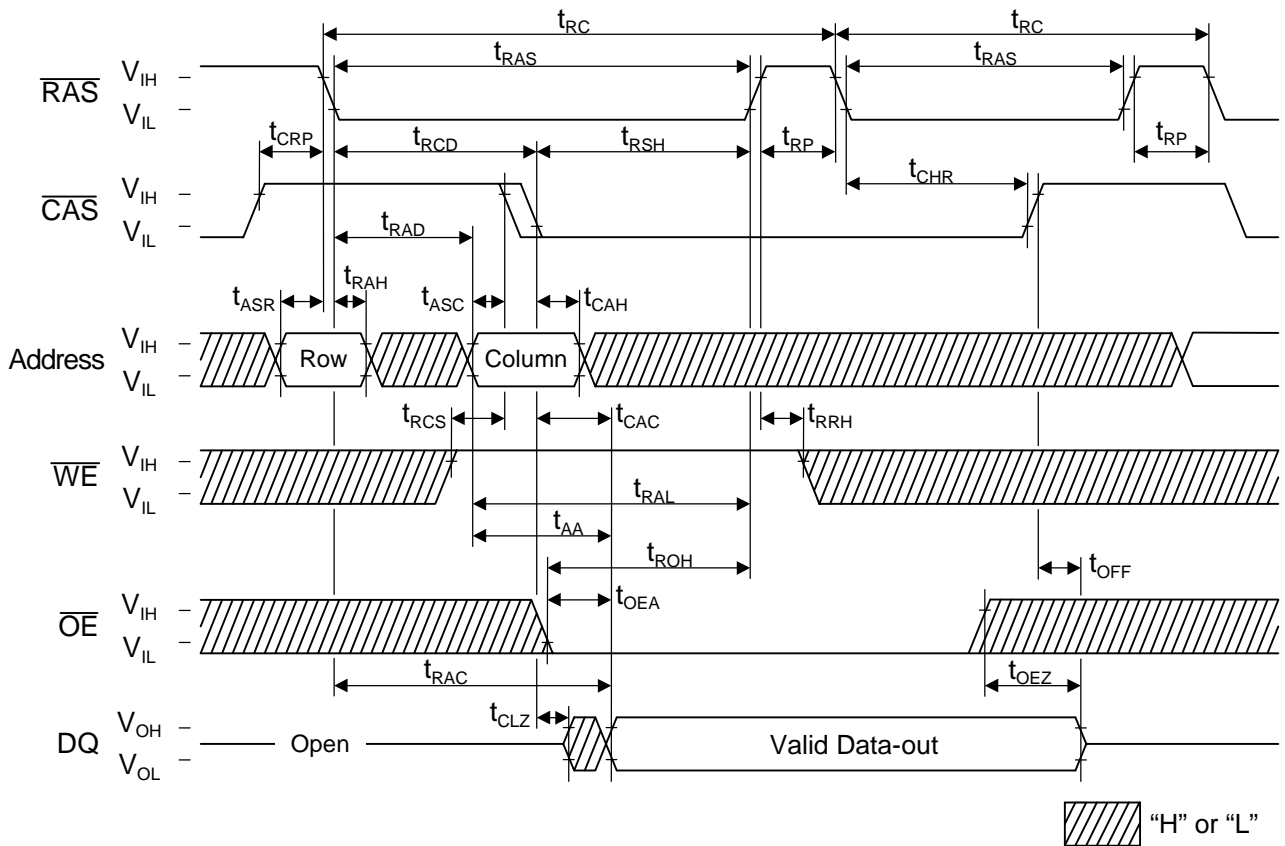

 "H" or "L"

• Hidden Refresh Write Cycle

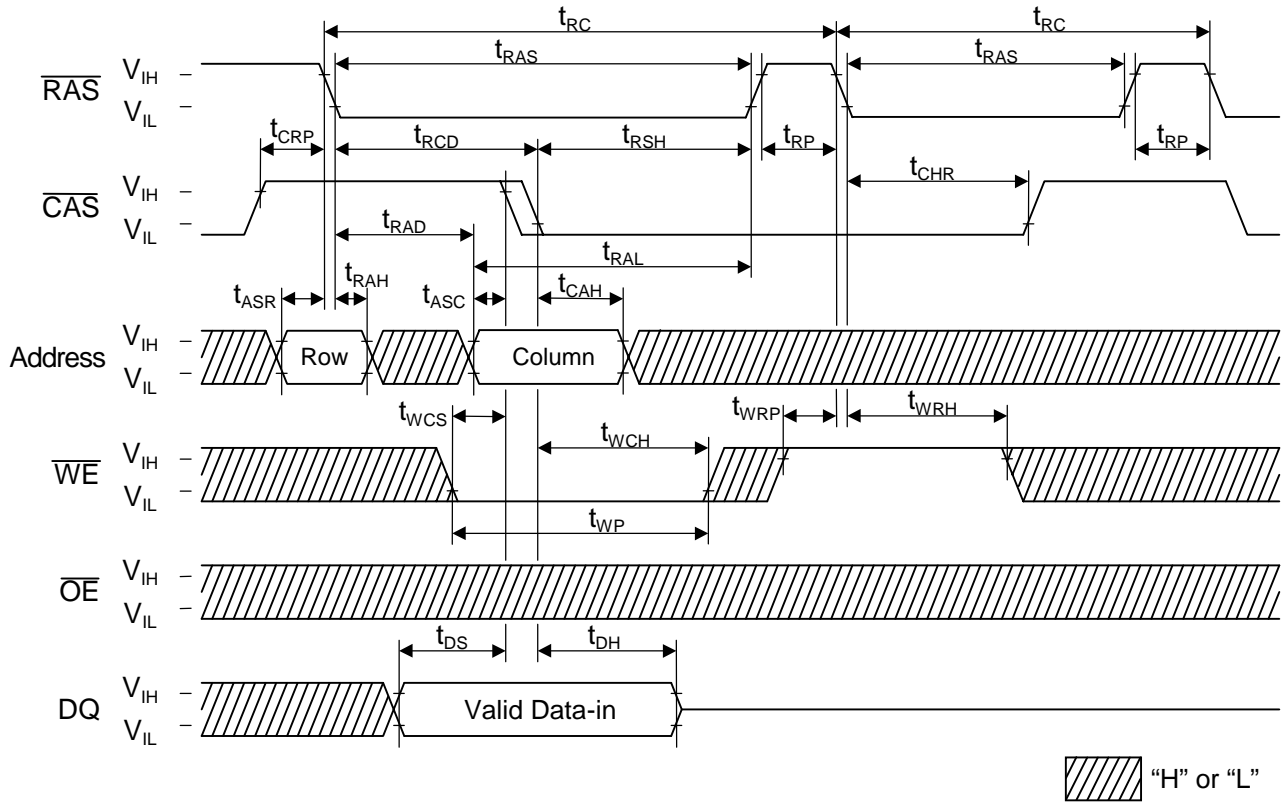

• Test Mode Initiate Cycle

