



Obsolescence Notice

This product is obsolete.

This information is available for your convenience only.

For more information on Zarlink's obsolete products and replacement product lists, please visit http://products.zarlink.com/obsolete_products/

***THIS DOCUMENT IS FOR MAINTENANCE
PURPOSES ONLY AND IS NOT
RECOMMENDED FOR NEW DESIGNS***

SP8799

225MHz ÷ 10/11 TWO MODULUS DIVIDER

The SP8799 is a low power programmable ÷10/11 counter. It divides by 10, when the control input is in the high state and by 11 when in the low state. An internal voltage regulator allows operation from a wide range of supply voltages.

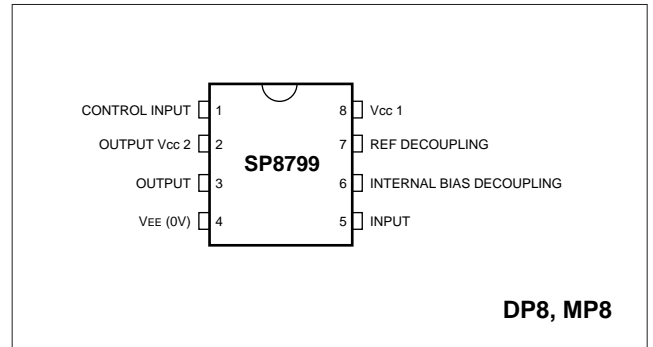

Figure 1 Pin connections - top view

FEATURES

- Very Low Power
- Control Input and Output CMOS/TTL Compatible
- AC Coupled Input
- Operation up to 9.5V using Internal Regulator

QUICK REFERENCE DATA

- Supply Voltage 5.2V or 6.8V to 9.5V
- Power consumption: 26mW Typical
- Temperature range: -40°C to +85°C

ABSOLUTE MAXIMUM RATINGS

Supply voltage	6.0V pins 7 & 8 tied
Supply voltage	13.5V pin 8, pin 7 decoupled
Storage temperature range	-55°C to +125°C
Max. Junction temperature	+175°C
Max. clock input voltage	2.5V p-p
Vcc2	Max. 10V

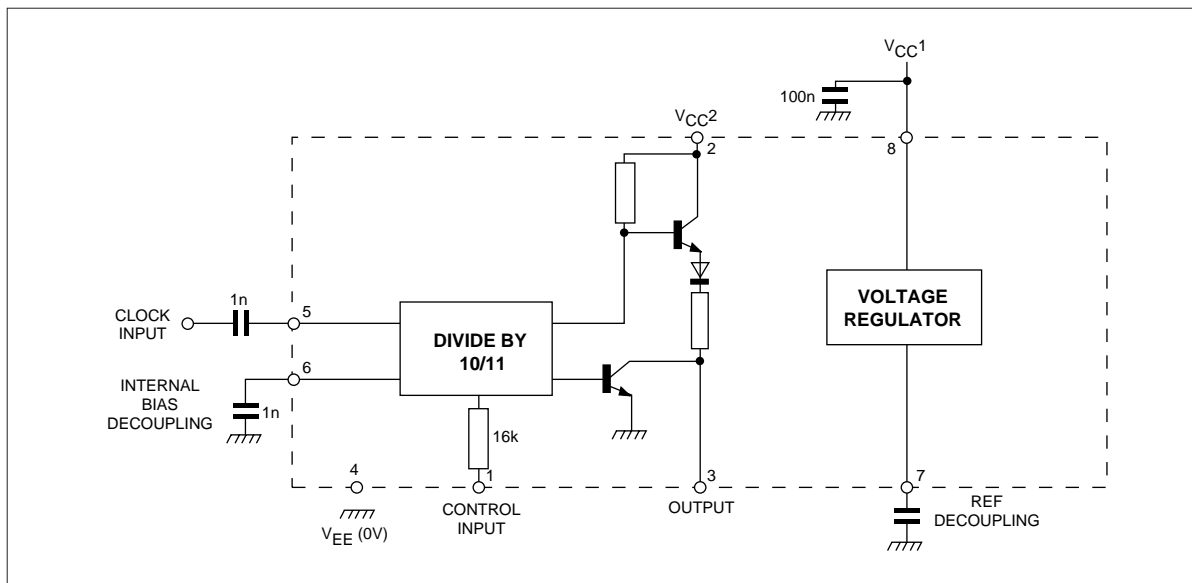

Figure 2 : Functional diagram SP8799

SP8799

ELECTRICAL CHARACTERISTICS

Test conditions (unless otherwise stated):]

Supply voltage : $V_{cc 1 \& 2} = 5.2 \pm 0.25V$ or $6.8V$ to $9.5V$ (see Operating Note 7):

$V_{EE} = 0V$; Temperature $T_{amb} = -40^{\circ}C$ to $+85^{\circ}C$

Characteristics	Symbol	Value		Units	Notes	Conditions
		Min.	Max.			
Maximum frequency (sinewave input)	f_{max}	225		MHz	Note 4	Input = 200-800mV p-p
Minimum frequency (sinewave input)	f_{min}		20	MHz	Note 4	Input = 400-800mV p-p
Power supply current	I_{EE}		7	mA	Note 4	
Control input high voltage	V_{INH}	4		V	Note 4	
Control input low voltage	V_{INL}		2	V	Note 4	
Output high voltage	V_{OH}	2.4		V	Note 4	Pins 2, 7 and 8 linked $V_{cc} = 4.95V$ $I_{OH} = 100\mu A$
Output low voltage	V_{OL}		0.5	V	Note 4	Pin 2 linked to 8 and 7 $I_{OL} = 1.6mA$
Set up time	t_s	14		ns	Note 3	$25^{\circ}C$
Release time	t_r	20		ns	Note 3	$25^{\circ}C$
Clock to output propagation time	t_p		45	ns	Note 3	$25^{\circ}C$

NOTES

1. Unless otherwise stated the electrical characteristics are guaranteed over full specified supply, frequency and temperature range.
2. The test configuration for dynamic testing is shown in Fig.6.
3. Guaranteed but not tested.
4. Tested onlt at $25^{\circ}C$

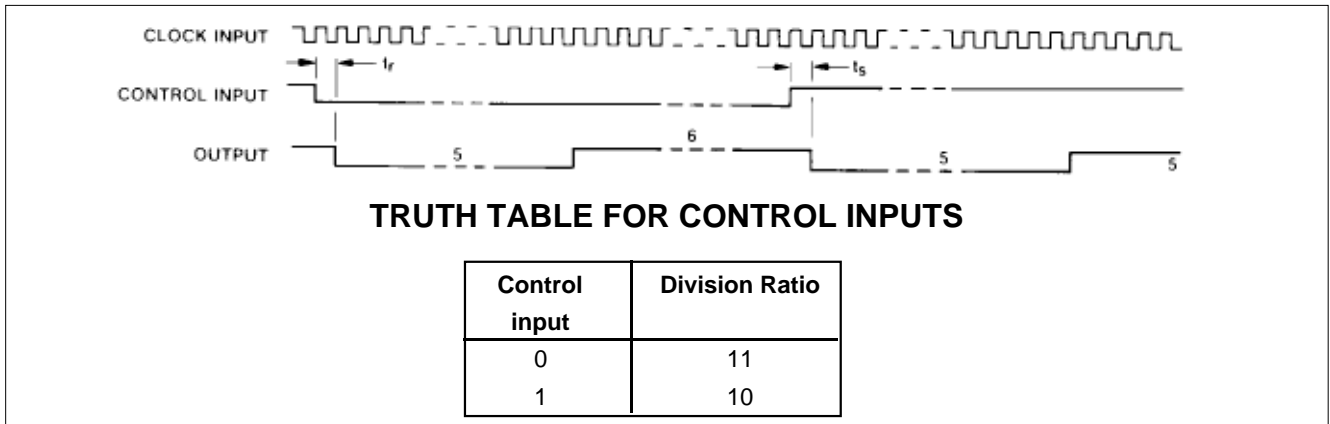
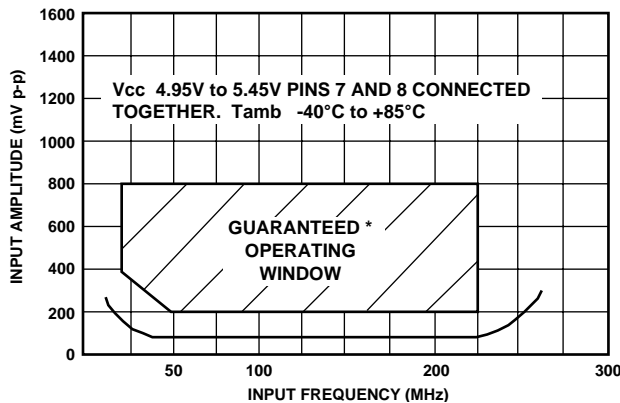

Figure 3 : Timing diagram SP8799

NOTES

The set-up time t_s is defined as the minimum time that can elapse between a L → H transition of the control input and the next L → H clock pulse transition to ensure that the ÷ 10 mode is selected.

The release time t_r is defined as the minimum time that can elapse between a H → L transition of the control input and the next L → H clock pulse transition to ensure that the ÷ 11 mode is selected.



*Tested as specified in table of Electrical Characteristics

Figure 4 : Input sensitivity SP8799

OPERATING NOTES

1. The clock input (Pin 5) should be capacitively coupled to the signal source. The input signal path is completed by coupling a capacitor from the internal bias decoupling, Pin 6 to ground.
2. The output stage which is normally open collector (Pin 2 open circuit) can be interfaced to CMOS. The open collector can be returned to a +10V line via a 5k resistor but the output sink current should not exceed 2mA. If interfacing to TTL is required then Pins 2 and 7 should be connected together to give a fan-out = 1. This will increase supply current by approximately 2mA.
3. The circuit will operate down to DC but a slew rate of better than 20V/~s is required.
4. The mark space ratio of the output is approximately 1.2:1 at 200MHz.
5. Input impedance is a function of frequency. See Fig.5.
6. If no signal is present the device will self-oscillate. If this is undesirable it may be prevented by connecting a 150k between unused input and ground. This reduces the input sensitivity by typically 50-100mV p-p.
7. The internal regulator has its input connected to Pin 8, while the internal reference voltage appears at Pin 7 and should be decoupled. For use from a 5.2V supply, Pins 7 and 8 should be connected together, and 5.2V applied to these pins. For operation from supply voltages in the range +6.8V to +9.5V, Pins 7 and 8 should be separately decoupled, and the supply voltage applied to Pin 8.

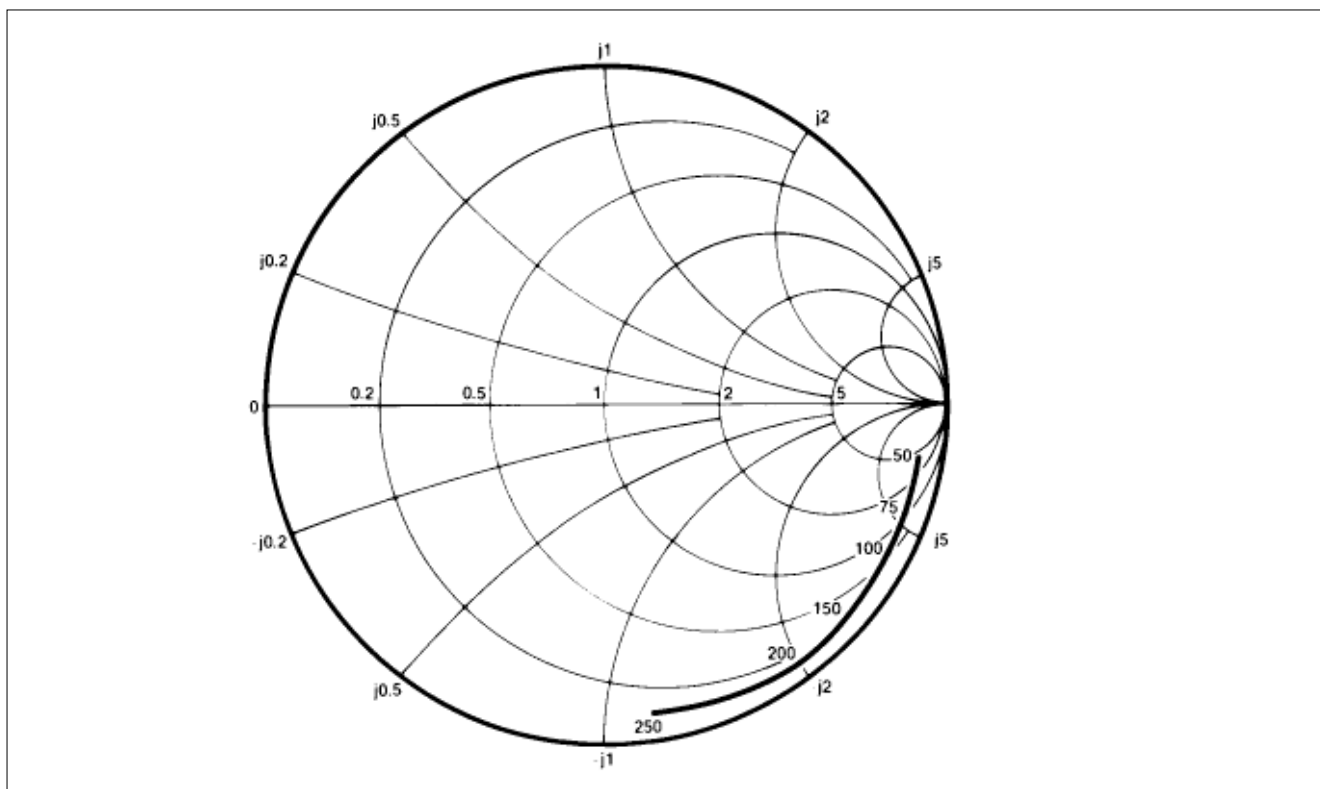

Figure 5 : Typical impedance. Test conditions: supply voltage 5.2V, ambient temperature 25°C, frequencies in MHz, impedance normalised to 50 ohms.

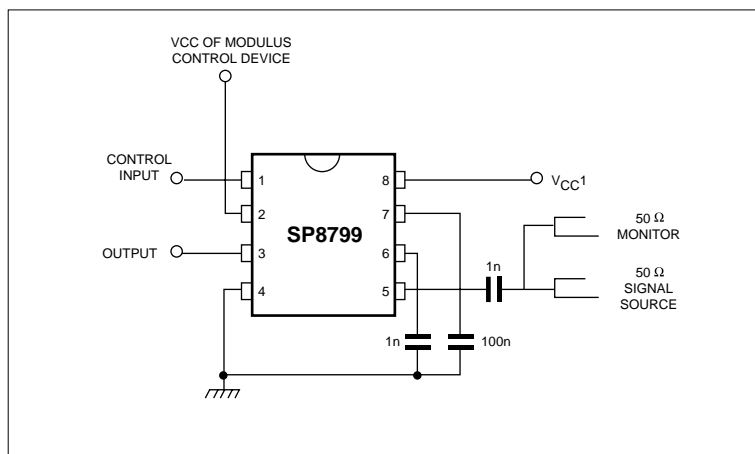

Figure 6 : Toggle frequency test circuit



**For more information about all Zarlink products
visit our Web Site at
www.zarlink.com**

Information relating to products and services furnished herein by Zarlink Semiconductor Inc. or its subsidiaries (collectively "Zarlink") is believed to be reliable. However, Zarlink assumes no liability for errors that may appear in this publication, or for liability otherwise arising from the application or use of any such information, product or service or for any infringement of patents or other intellectual property rights owned by third parties which may result from such application or use. Neither the supply of such information or purchase of product or service conveys any license, either express or implied, under patents or other intellectual property rights owned by Zarlink or licensed from third parties by Zarlink, whatsoever. Purchasers of products are also hereby notified that the use of product in certain ways or in combination with Zarlink, or non-Zarlink furnished goods or services may infringe patents or other intellectual property rights owned by Zarlink.

This publication is issued to provide information only and (unless agreed by Zarlink in writing) may not be used, applied or reproduced for any purpose nor form part of any order or contract nor to be regarded as a representation relating to the products or services concerned. The products, their specifications, services and other information appearing in this publication are subject to change by Zarlink without notice. No warranty or guarantee express or implied is made regarding the capability, performance or suitability of any product or service. Information concerning possible methods of use is provided as a guide only and does not constitute any guarantee that such methods of use will be satisfactory in a specific piece of equipment. It is the user's responsibility to fully determine the performance and suitability of any equipment using such information and to ensure that any publication or data used is up to date and has not been superseded. Manufacturing does not necessarily include testing of all functions or parameters. These products are not suitable for use in any medical products whose failure to perform may result in significant injury or death to the user. All products and materials are sold and services provided subject to Zarlink's conditions of sale which are available on request.

Purchase of Zarlink's I²C components conveys a licence under the Philips I²C Patent rights to use these components in and I²C System, provided that the system conforms to the I²C Standard Specification as defined by Philips.

Zarlink, ZL and the Zarlink Semiconductor logo are trademarks of Zarlink Semiconductor Inc.

Copyright Zarlink Semiconductor Inc. All Rights Reserved.

TECHNICAL DOCUMENTATION - NOT FOR RESALE
