

Voltage Controlled Multivibrator

The MC1658 is a voltage-controlled multivibrator which provides appropriate level shifting to produce an output compatible with MECL III and MECL 10,000 logic levels. Frequency control is accomplished through the use of voltage-variable current sources which control the slew rate of a single external capacitor.

The bias filter may be used to help eliminate ripple on the output voltage levels at high frequencies and the input filter may be used to decouple noise from the analog input signal.

Pinout: 16-Lead Package (Top View)

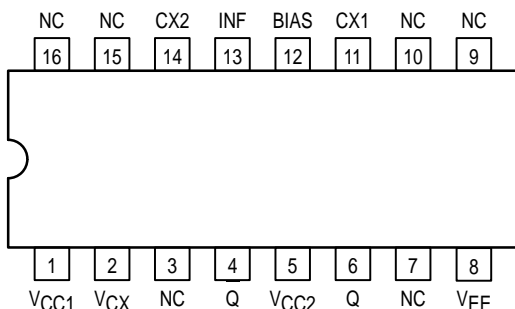

LOGIC DIAGRAM

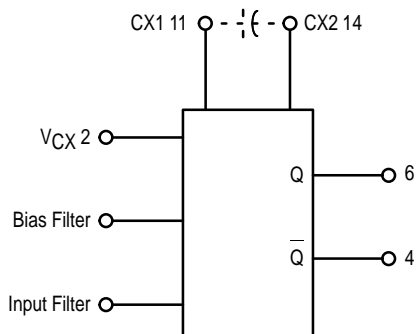

VCC1 = Pin 1
VCC2 = Pin 5
VEE = Pin 8

MC1658

VOLTAGE CONTROLLED MULTIVIBRATOR

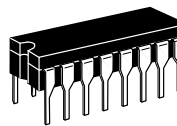

L SUFFIX
16-LEAD CERAMIC PACKAGE
CASE 620-10

Not Recommended for New Designs

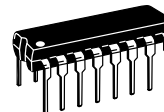

P SUFFIX
16-LEAD PLASTIC PACKAGE
CASE 648-08

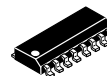

D SUFFIX
PLASTIC SOIC PACKAGE
CASE 751B-05

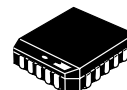

FN SUFFIX
20-LEAD PLCC PACKAGE
CASE 775-02

Pin Conversion Table

16 PIN DIP	1	2	3	4	5	6	7	8	9	10	11	12	13	14	15	16
20 PIN PLCC	2	3	4	5	7	8	9	10	12	13	14	15	17	18	19	20



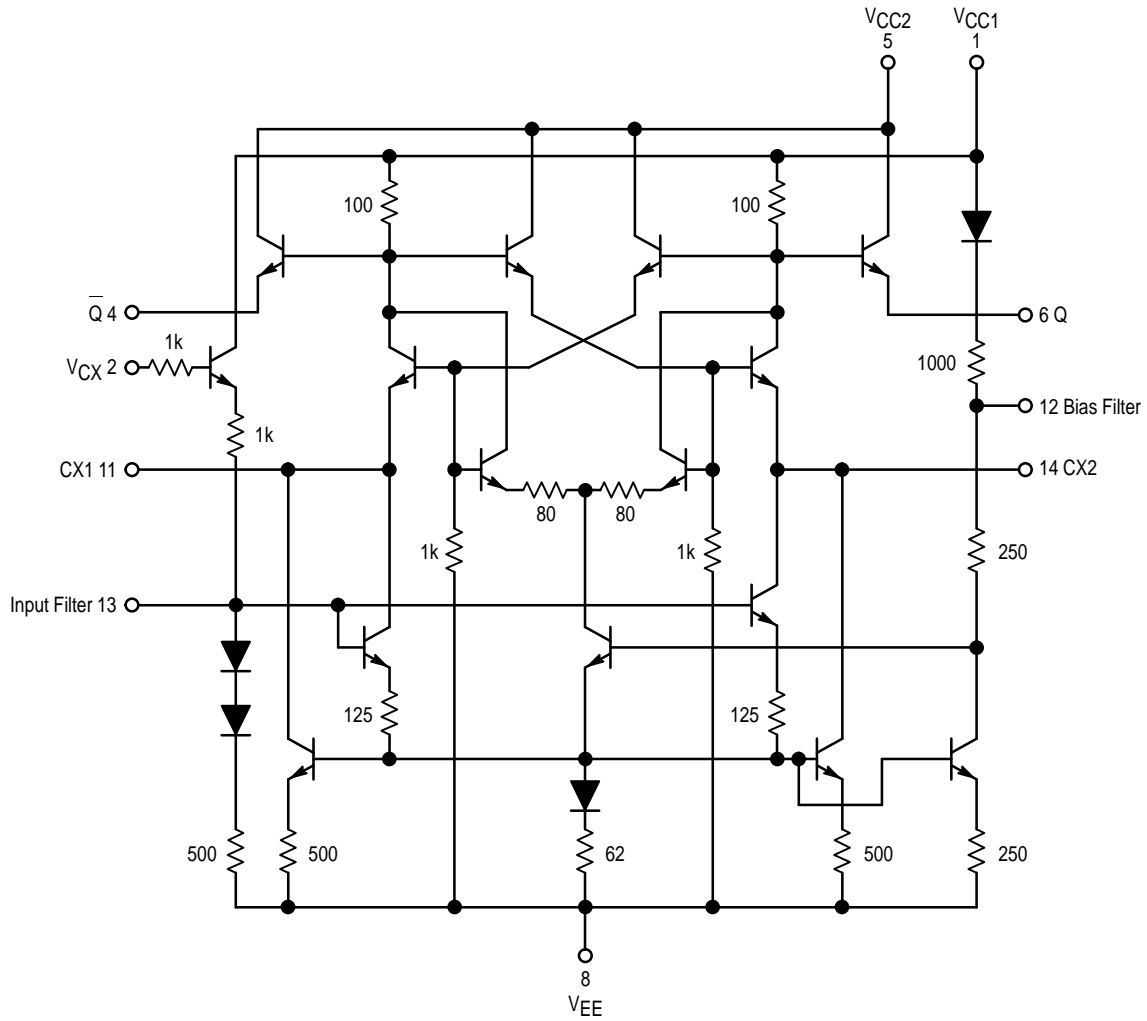

Figure 1. Circuit Schematic

TEST VOLTAGE VALUES

@ Test Temperature	Vdc ±1%			
	V _{IH}	V _{IL}	V ₃	I _{IHA}
-30°C	0	-2.0	-1.0	+2.0
+25°C	0	-2.0	-1.0	+2.0
+85°C	0	-2.0	-1.0	+2.0

Note: SOIC "D" package guaranteed -30°C to +70°C only

ELECTRICAL CHARACTERISTICS ($V_{EE} = -5.2V$, $V_{CC} = 0V$ [GND])

Symbol	Characteristic	-30°C		+25°C		+85°C		Unit	Condition
		Min	Max	Min	Max	Min	Max		
I_E	Power Supply Drain Current	-	-	-	32	-	-	mAdc	V_{IH} to V_{CX} Limit Applies for 1 or 2
I_{inH}	Input Current	-	-	-	350	-	-	μ Adc	V_{IH} to V_{CX} ¹
V_{OH}	Output Voltage "Q" HIGH	-1.045	-0.875	-0.96	-0.81	-0.89	-0.7	Vdc	V_3 to V_{CX} . Limits Apply for 1 or 2
V_{OL}	Output Voltage "Q" LOW	-1.89	-1.65	-1.85	-1.62	-1.83	-1.575	Vdc	

AC CHARACTERISTICS ($V_{EE} = -3.2V$, $V_{CC} = +2.0V$)

Symbol	Characteristic	-30°C		+25°C			+85°C		Unit	Condition (See Figure 2)
		Min	Max	Min	Typ	Max	Min	Max		
t^+	Rise Time (10% to 90%)	-	2.7	-	1.6	2.7	-	3.0	ns	V_{IH} to V_{CX} , CX1 ⁴ from Pin 11 to Pin 14
t^-	Fall Time (10% to 90%)	-	2.7	-	1.4	2.7	-	3.0	ns	
f_{osc1}	Oscillator Frequency	130	-	130	155	175	110	-	MHz	V_{IH} to V_{CX} , CX2 ⁵ from Pin 11 to Pin 14
f_{osc2}		-	-	78	100	120	-	-		
TR ³	Tuning Ratio Test	-	-	3.1	4.5	-	-	-	-	CX2 ⁵ from Pin 11 to Pin 14

- 1 Germanium diode (0.4 drop) forward biased from 11 to 14 (11 → 14).
- 2 Germanium diode (0.4 drop) forward biased from 14 to 11 (11 ← 14).

3 $TR = \frac{\text{Output frequency at } V_{CX} = GND}{\text{Output frequency at } V_{CX} = -2.0V}$

- 4 CX1 = 5.0pF connected from pin 11 to pin 14.
- 5 CX2 = 10pF connected from pin 11 to pin 14.

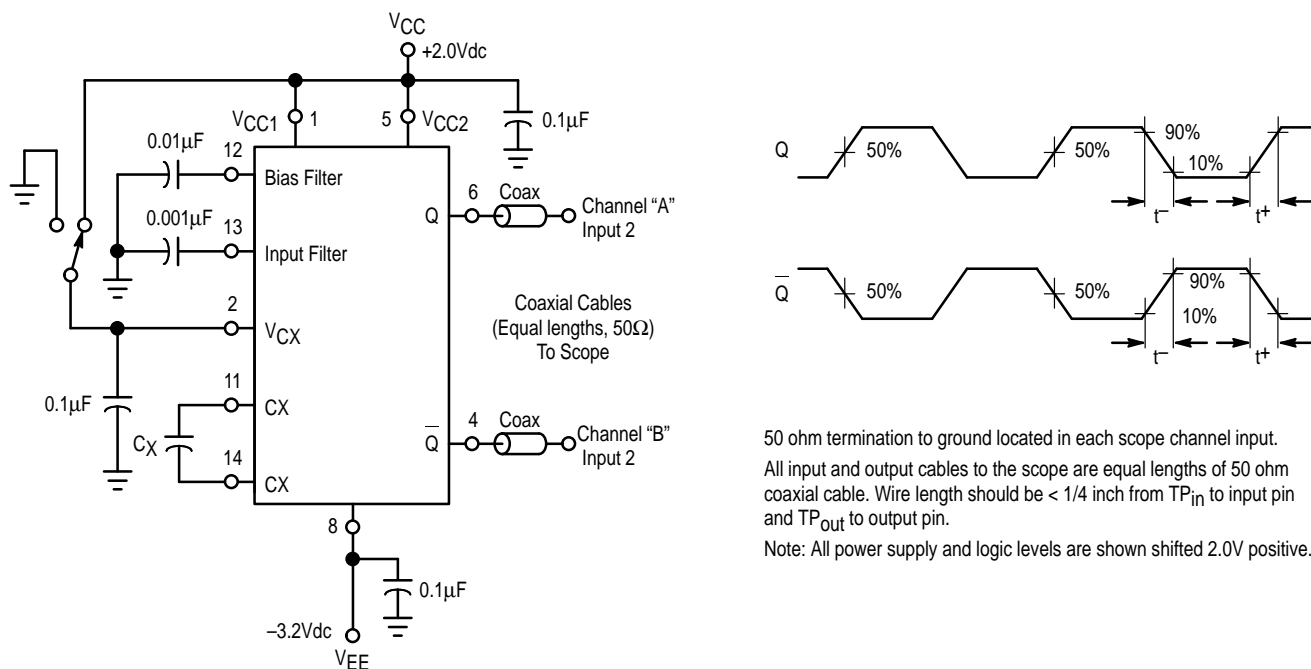

Figure 2. AC Test Circuit and Waveforms

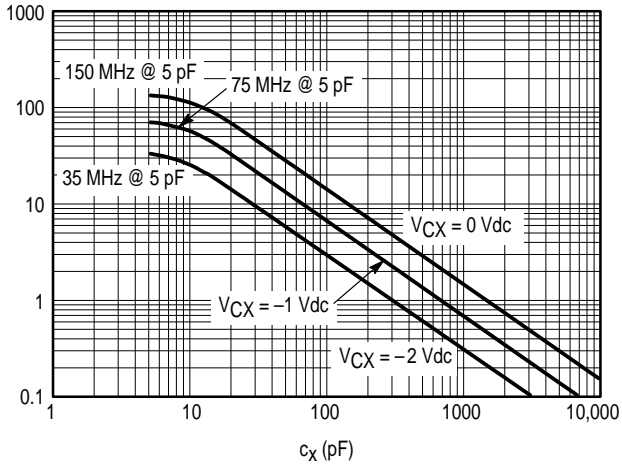

Figure 3. Output Frequency versus Capacitance for Various Values of Input Voltage

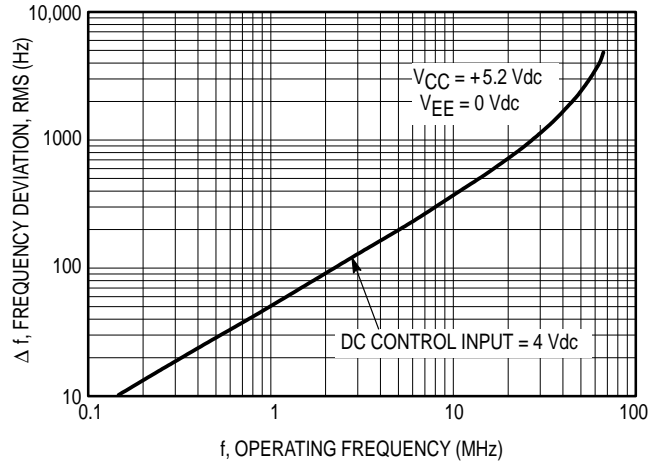
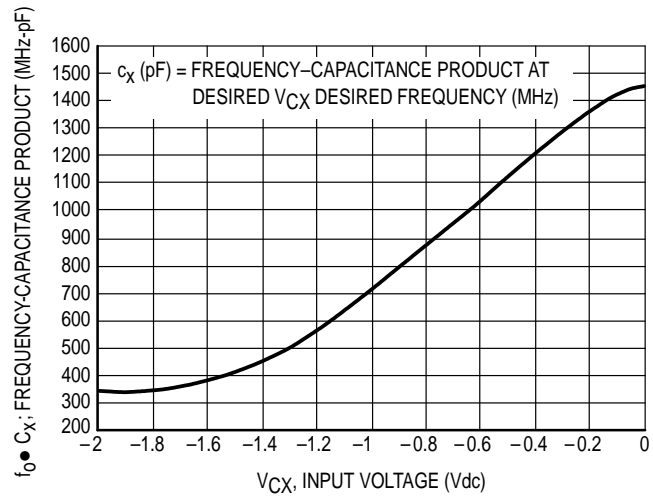

Figure 4. RMS Noise Deviation versus Operating Frequency



$V_{EE} = -5.2V, V_{CC} = 0V.$
 For Use at $V_{EE} = 0V, V_{CC} = +5V$ ($V_{CXP} = +5V - V_{CX}$)
 V_{CXP} = Positive Input Voltage

Figure 5. Frequency Capacitance Product versus Control Voltage (V_{CX})

OUTLINE DIMENSIONS

L SUFFIX
CERAMIC PACKAGE
CASE 620-10
ISSUE V

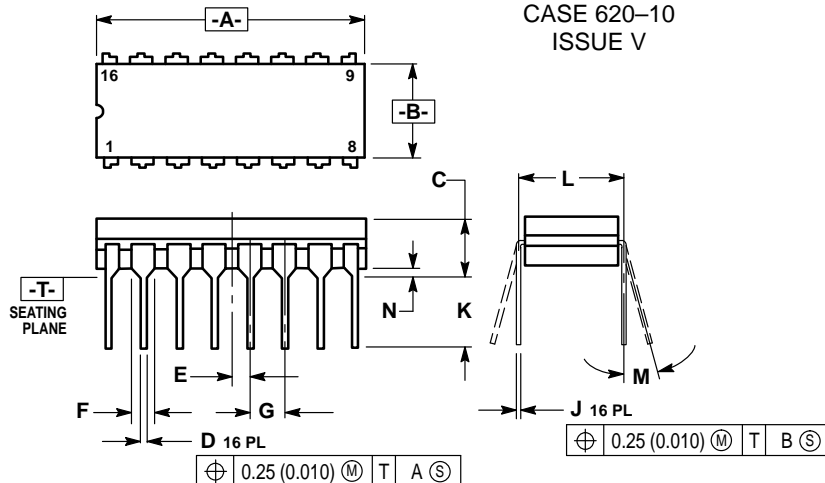

- NOTES:
1. DIMENSIONING AND TOLERANCING PER ANSI Y14.5M, 1982.
 2. CONTROLLING DIMENSION: INCH.
 3. DIMENSION L TO CENTER OF LEAD WHEN FORMED PARALLEL.
 4. DIMENSION F MAY NARROW TO 0.076 (0.003) WHERE THE LEAD ENTERS THE CERAMIC BODY.

DIM	INCHES		MILLIMETERS	
	MIN	MAX	MIN	MAX
A	0.750	0.785	19.05	19.93
B	0.240	0.295	6.10	7.49
C	—	0.200	—	5.08
D	0.015	0.020	0.39	0.50
E	0.050 BSC		1.27 BSC	
F	0.085	0.065	1.40	1.65
G	0.100 BSC		2.54 BSC	
J	0.008	0.015	0.21	0.38
K	0.125	0.170	3.18	4.31
L	0.300 BSC		7.62 BSC	
M	0°	15°	0°	15°
N	0.020	0.040	0.51	1.01

P SUFFIX
PLASTIC PACKAGE
CASE 648-08
ISSUE R

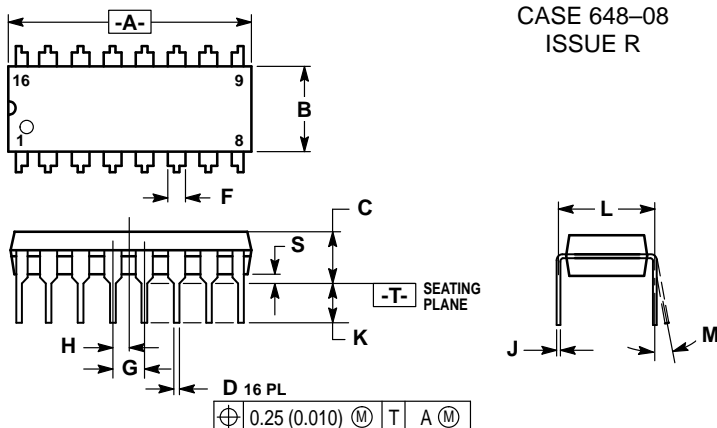

- NOTES:
1. DIMENSIONING AND TOLERANCING PER ANSI Y14.5M, 1982.
 2. CONTROLLING DIMENSION: INCH.
 3. DIMENSION L TO CENTER OF LEADS WHEN FORMED PARALLEL.
 4. DIMENSION B DOES NOT INCLUDE MOLD FLASH.
 5. ROUNDED CORNERS OPTIONAL.

DIM	INCHES		MILLIMETERS	
	MIN	MAX	MIN	MAX
A	0.740	0.770	18.80	19.55
B	0.250	0.270	6.35	6.85
C	0.145	0.175	3.69	4.44
D	0.015	0.021	0.39	0.53
F	0.040	0.070	1.02	1.77
G	0.100 BSC		2.54 BSC	
H	0.050 BSC		1.27 BSC	
J	0.008	0.015	0.21	0.38
K	0.110	0.130	2.80	3.30
L	0.295	0.305	7.50	7.74
M	0°	10°	0°	10°
S	0.020	0.040	0.51	1.01

D SUFFIX
PLASTIC SOIC PACKAGE
CASE 751B-05
ISSUE J

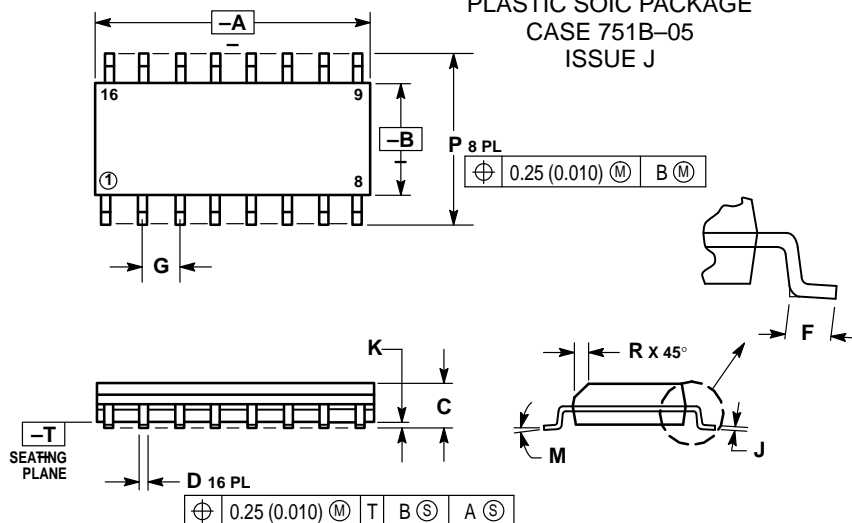

- NOTES:
1. DIMENSIONING AND TOLERANCING PER ANSI Y14.5M, 1982.
 2. CONTROLLING DIMENSION: MILLIMETER.
 3. DIMENSIONS A AND B DO NOT INCLUDE MOLD PROTRUSION.
 4. MAXIMUM MOLD PROTRUSION 0.15 (0.006) PER SIDE.
 5. DIMENSION D DOES NOT INCLUDE DAMBAR PROTRUSION. ALLOWABLE DAMBAR PROTRUSION SHALL BE 0.127 (0.005) TOTAL IN EXCESS OF THE D DIMENSION AT MAXIMUM MATERIAL CONDITION.

DIM	MILLIMETERS		INCHES	
	MIN	MAX	MIN	MAX
A	9.80	10.00	0.386	0.393
B	3.80	4.00	0.150	0.157
C	1.35	1.75	0.054	0.068
D	0.35	0.49	0.014	0.019
F	0.40	1.25	0.016	0.049
G			1.27 BSC	0.050 BSC
J	0.19	0.25	0.008	0.009
K	0.10	0.25	0.004	0.009
M	0°	7°	0°	7°
P	5.80	6.20	0.229	0.244
R	0.25	0.50	0.010	0.019

OUTLINE DIMENSIONS

FN SUFFIX
 PLASTIC PLCC PACKAGE
 CASE 775-02
 ISSUE C

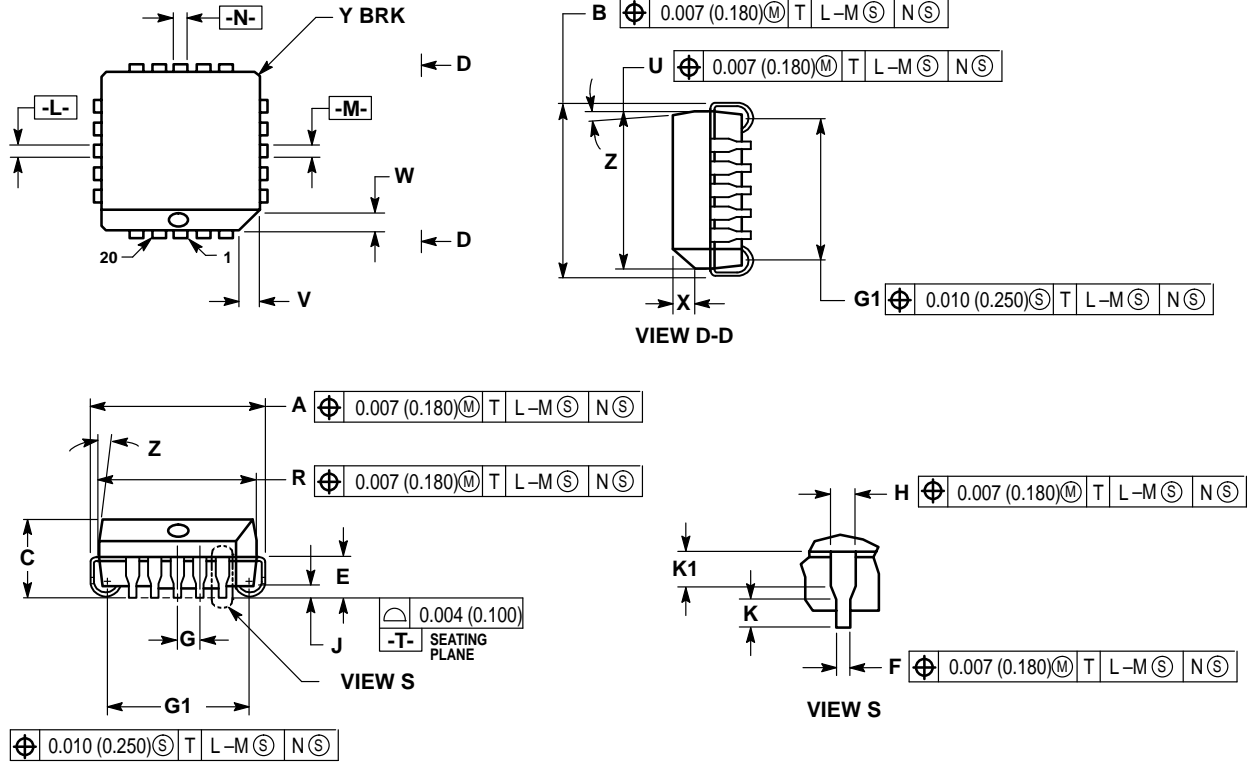

NOTES:

- DATUMS -L-, -M-, AND -N- DETERMINED WHERE TOP OF LEAD SHOULDER EXITS PLASTIC BODY AT MOLD PARTING LINE.
- DIM G1, TRUE POSITION TO BE MEASURED AT DATUM -T-, SEATING PLANE.
- DIM R AND U DO NOT INCLUDE MOLD FLASH. ALLOWABLE MOLD FLASH IS 0.010 (0.250) PER SIDE.
- DIMENSIONING AND TOLERANCING PER ANSI Y14.5M, 1982.
- CONTROLLING DIMENSION: INCH.
- THE PACKAGE TOP MAY BE SMALLER THAN THE PACKAGE BOTTOM BY UP TO 0.012 (0.300). DIMENSIONS R AND U ARE DETERMINED AT THE OUTERMOST EXTREMES OF THE PLASTIC BODY EXCLUSIVE OF MOLD FLASH, TIE BAR BURRS, GATE BURRS AND INTERLEAD FLASH, BUT INCLUDING ANY MISMATCH BETWEEN THE TOP AND BOTTOM OF THE PLASTIC BODY.
- DIMENSION H DOES NOT INCLUDE DAMBAR PROTRUSION OR INTRUSION. THE DAMBAR PROTRUSION(S) SHALL NOT CAUSE THE H DIMENSION TO BE GREATER THAN 0.037 (0.940). THE DAMBAR INTRUSION(S) SHALL NOT CAUSE THE H DIMENSION TO BE SMALLER THAN 0.025 (0.635).

DIM	INCHES		MILLIMETERS	
	MIN	MAX	MIN	MAX
A	0.385	0.395	9.78	10.03
B	0.385	0.395	9.78	10.03
C	0.165	0.180	4.20	4.57
E	0.090	0.110	2.29	2.79
F	0.013	0.019	0.33	0.48
G	0.050 BSC		1.27 BSC	
H	0.026	0.032	0.66	0.81
J	0.020	—	0.51	—
K	0.025	—	0.64	—
R	0.350	0.356	8.89	9.04
U	0.350	0.356	8.89	9.04
V	0.042	0.048	1.07	1.21
W	0.042	0.048	1.07	1.21
X	0.042	0.056	1.07	1.42
Y	—	0.020	—	0.50
Z	2°		10°	
G1	0.310	0.330	7.88	8.38
K1	0.040	—	1.02	—