

SANYO	NO.1977B	LB1710
	Low-Active, 7-Unit, Darlington Transistor Array	

Applications

- . Relay drivers, printer drivers, lamp drivers

Features

- . Input: Low-active type, Output: Sink type
- . High breakdown voltage $V_{CE0}=50V$
- . High-current drive $I_{Cmax}=400mA$
- . On-chip input diodes

Absolute Maximum Ratings at $T_a=25^{\circ}C$

			unit
Maximum Supply Voltage	V_{CCmax}	10	V
Collector-to-Emitter Voltage	V_{CE0}	50	V
Collector Current	I_C Per unit	400	mA
Input Voltage	V_{IN}	10	V
Allowable Power Dissipation	P_{dmax}	1.5	W
Operating Temperature	T_{opr}	-20 to +75	$^{\circ}C$
Storage Temperature	T_{stg}	-55 to +150	$^{\circ}C$

Allowable Operating Conditions at $T_a=25^{\circ}C$

			min	typ	max	unit
Supply Voltage	V_{CC}		4	5	8	V
Collector Current	I_C	$V_{CC}=5V, Duty \leq 25\%$			400	mA
(per unit)		$V_{CC}=5V, Duty \leq 100\%$			140	mA
Input "H"-Level Voltage	V_{INH}	$I_C(LEAK)=50\mu A$	$V_{CC}-0.5$		V_{CC}	V
Input "L"-Level Voltage	V_{INL}	$I_C=0.35A$	0	$V_{CC}-3.5$		V

Electrical Characteristics at $T_a=25^{\circ}C$

			Test Circuit	min	typ	max	unit
Collector to Emitter Cutoff Current	I_{CE0}	$I_{IN}=0A, V_{CC}=5V, V_{CE}=50V$	1			100	μA
Collector to Emitter Saturation Voltage	$V_{CE(sat)}^1$	$V_{IN}=2V, V_{CC}=5V, I_C=0.35A$	2		1.2	2.0	V
Collector to Emitter Saturation Voltage	$V_{CE(sat)}^2$	$V_{IN}=2V, V_{CC}=5V, I_C=0.2A$	2		1.0	1.6	V

Continued on next page.

Pin Assignment and Equivalent Circuit Block Diagram

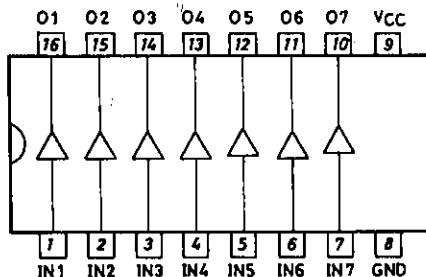

Package Dimensions 3064-D16TR (unit: mm)

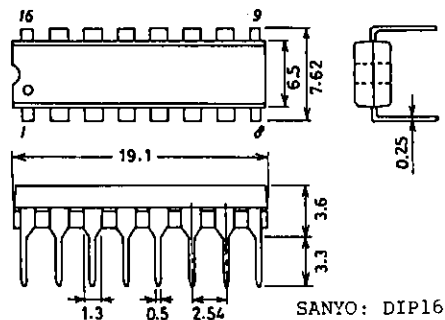

Continued from preceding page.

			Circuit	min	typ	max	unit
Input Current (ON-state)	$I_{IN(ON)}$	$V_{IN}=1.5V, V_{CC}=5V$	3			-0.58	mA
Input Current (OFF-state)	$I_{IN(OFF)}$	$V_{IN}=10V(7ch), V_{CC}=0V$	4			100	μA
Input Voltage	$V_{IN(ON)}$	$V_{CC}=5V, I_C=0.35A$	5	0		1.5	V
Current Dissipation (ON-state)	$I_{CC(ON)}$	$V_N=1.5A, V_{CC}=5V$	6			3	mA
Current Dissipation (OFF-state)	$I_{CC(OFF)}$	$I_{IN}=0A(7ch), V_{CC}=5V$	6			100	μA

Test Circuits

Test Circuit 1

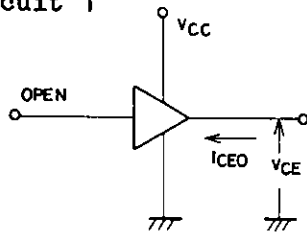

Test Circuit 2

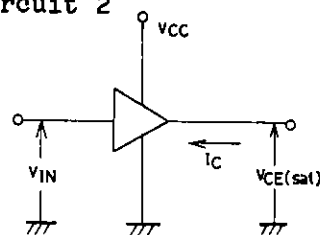

Test Circuit 3

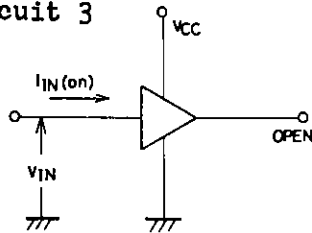

Test Circuit 4

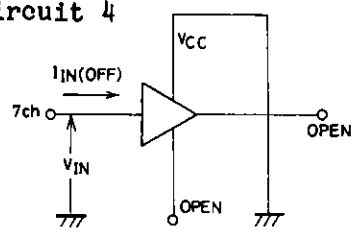

Test Circuit 5

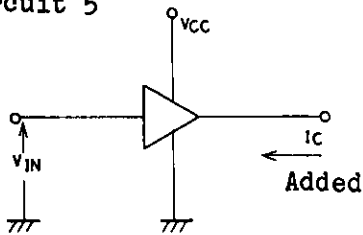

Test Circuit 6

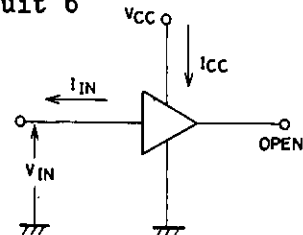

Equivalent Circuit

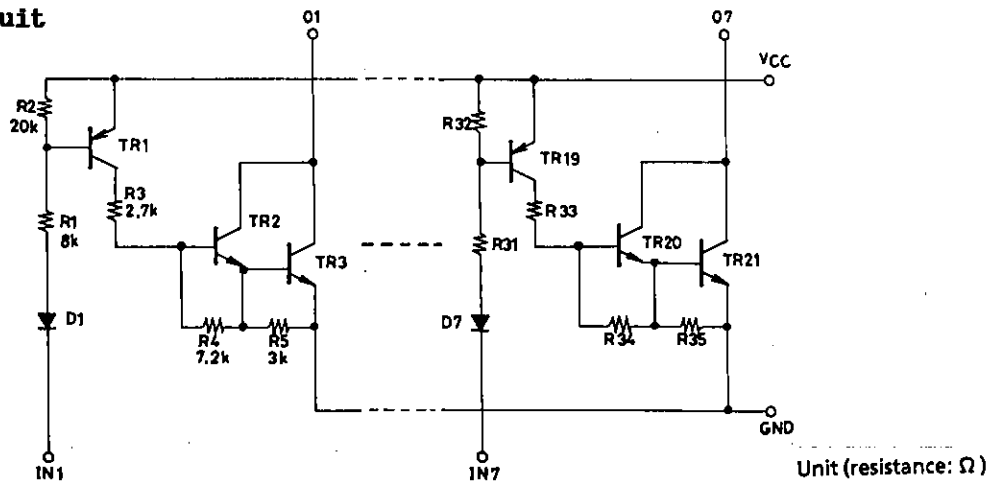

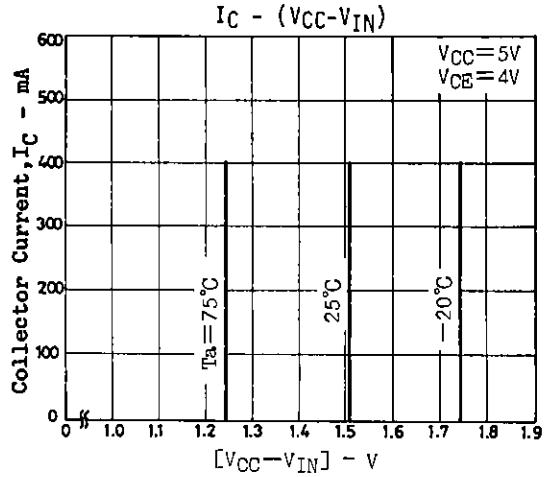
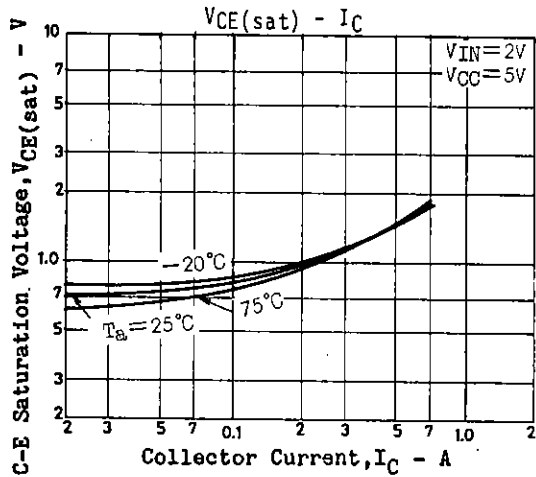
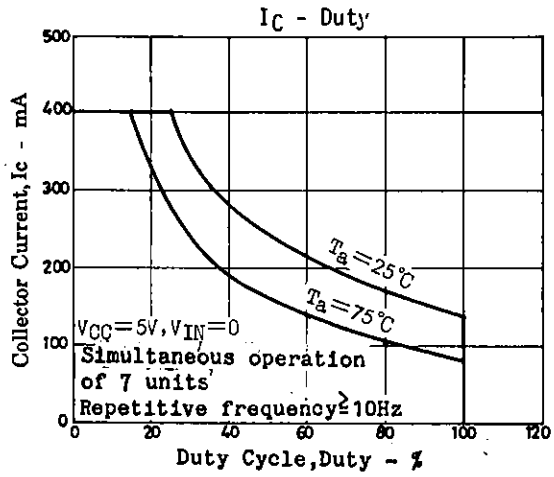
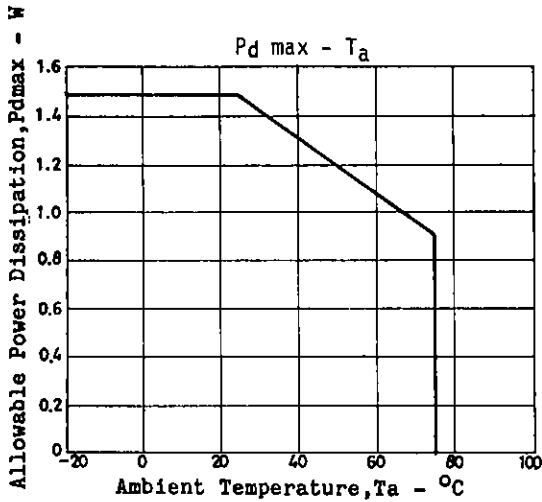

- No products described or contained herein are intended for use in surgical implants, life-support systems, aerospace equipment, nuclear power control systems, vehicles, disaster/crime-prevention equipment and the like, the failure of which may directly or indirectly cause injury, death or property loss.
- Anyone purchasing any products described or contained herein for an above-mentioned use shall:
 - ① Accept full responsibility and indemnify and defend SANYO ELECTRIC CO., LTD., its affiliates, subsidiaries and distributors and all their officers and employees, jointly and severally, against any and all claims and litigation and all damages, cost and expenses associated with such use:
 - ② Not impose any responsibility for any fault or negligence which may be cited in any such claim or litigation on SANYO ELECTRIC CO., LTD., its affiliates, subsidiaries and distributors or any of their officers and employees jointly or severally.
- Information (including circuit diagrams and circuit parameters) herein is for example only; it is not guaranteed for volume production. SANYO believes information herein is accurate and reliable, but no guarantees are made or implied regarding its use or any infringements of intellectual property rights or other rights of third parties.