



LB1846M, 1848M

Low-Voltage/Low Saturation Voltage Type Bidirectional Motor Driver

Overview

The LB1846M and LB1848M are 2-channel low-voltage, low saturation voltage type bidirectional motor driver ICs that are optimal for use as 2-phase stepping motor drivers in printers, floppy disk drives, and cameras and other portable equipment. The output circuits are of the bipolar type, with pnp transistors in the upper side and npn transistors in the lower side, and they achieve low saturation output and low power characteristics despite being provided in a miniature package.

Both of these IC products can directly control a motor from signals from a microcontroller. The LB1846M is optimal for 1-2 phase excitation drive for 2-phase stepping motors using 4-input logic (IN1, IN2, IN3, and IN4) and the LB1848M is optimal for 2-phase excitation drive for 2-phase stepping motors using 3-input logic (ENA, IN1, and IN2).

Another point is that these ICs include built-in thermal shutdown circuits so that IC scorching or burning is prevented in advance even if the IC outputs are shorted. Additionally, the MFP-10S miniature package used supports reduced-space mounting.

Features

- Optimal for 1-2 phase excitation drive for 2-phase stepping motors (LB1846M)
- Optimal for 2 phase excitation drive for 2-phase stepping motors (LB1848M)
- Low saturation voltage. $V_{O(sat)} = 0.55$ V typical at $I_O = 400$ mA
- Standby current: zero
- Thermal shutdown circuit
- Miniature package: MFP-10S (6.5 × 5.1 mm)
- Through-current prevention circuit (LB1848M only)
- "Soft off" function that reduces power supply line noise when switching from drive to standby modes. (Requires the use of one external capacitor.) (LB1848M only)
- No limitations on the magnitude relationship between the power supply voltage (V_{CC}) and the input voltage (V_{IN})

Package Dimensions

unit: mm

3086A-MFP10S

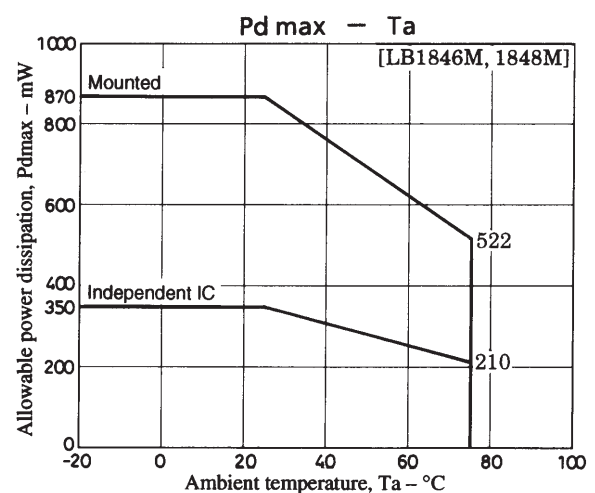
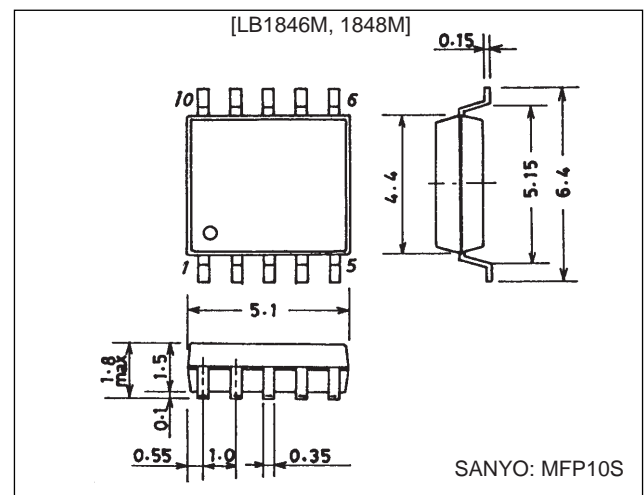

LB1846M, 1848M

Specifications

Absolute Maximum Ratings at $T_a = 25^\circ\text{C}$

Parameter	Symbol	Conditions	Ratings	Unit
Maximum supply voltage	V_{CC} max		-0.3 to +8.0	V
Output voltage	V_{OUT}		$V_{CC} + V_{SF}$	V
Input voltage	V_{IN}		-0.3 to +8.0	V
Ground pin outflow current	I_{GND}	Per channel	800	mA
Allowable power dissipation	Pd max1	Independent IC	350	mW
	Pd max2	When mounted*	870	mW
Operating temperature	T_{opr}		-20 to +75	$^\circ\text{C}$
Storage temperature	T_{stg}		-40 to +150	$^\circ\text{C}$

Note: *On the specified circuit board (a $114.3 \times 76.2 \times 1.5$ -mm glass-epoxy printed circuit board)

Allowable Operating Ranges at $T_a = 25^\circ\text{C}$

Parameter	Symbol	Conditions	Ratings	Unit
Supply voltage	V_{CC}		2.5 to 7.5	V
Input high-level voltage	V_{IH}		2.0 to 7.5	V
Input low-level voltage	V_{IL}		-0.3 to +0.7	V

Electrical Characteristics at $T_a = 25^\circ\text{C}$, $V_{CC} = 5.0\text{ V}$

Parameter	Symbol	Conditions	Ratings			Unit
			min	typ	max	
[LB1846M]						
Current drain	I_{CC0}	IN1, 2, 3, 4 = 0 V		0.1	10	μA
	I_{CC1}	IN1, 3 = 3 V, IN2, 4 = 0 V		30	40	mA
Output saturation voltage	V_{OUT1}	$V_{IN} = 3\text{ V or } 0\text{ V}$, $V_{CC} = 3\text{ to } 7.5\text{ V}$, $I_{OUT} = 200\text{ mA}$		0.27	0.4	V
	V_{OUT2}	$V_{IN} = 3\text{ V or } 0\text{ V}$, $V_{CC} = 4\text{ to } 7.5\text{ V}$, $I_{OUT} = 400\text{ mA}$		0.55	0.8	V
Input current	I_{IN}	$V_{IN} = 5\text{ V}$		150	200	μA
[Spark Killer Diode]						
Reverse current	$I_S(\text{leak})$				30	μA
Forward voltage	V_{SF}	$I_{OUT} = 400\text{ mA}$			1.7	V
[LB1848M]						
Current drain	I_{CC0}	ENA = 0 V, $V_{IN} = 3\text{ V or } 0\text{ V}$		0.1	10	μA
	I_{CC1}	ENA = 3 V, $V_{IN} = 3\text{ V or } 0\text{ V}$		25	35	mA
Output saturation voltage	V_{OUT1}	ENA = 3 V, $V_{IN} = 3\text{ V or } 0\text{ V}$, $V_{CC} = 3\text{ to } 7.5\text{ V}$, $I_{OUT} = 200\text{ mA}$		0.27	0.4	V
	V_{OUT2}	ENA = 3 V, $V_{IN} = 3\text{ V or } 0\text{ V}$, $V_{CC} = 4\text{ to } 7.5\text{ V}$, $I_{OUT} = 400\text{ mA}$		0.55	0.8	V
Input current 1	I_{IN}	$V_{IN} = 5\text{ V}$		75	100	μA
Input current 2	I_{ENA}	ENA = 5 V		85	110	μA
[Spark Killer Diode]						
Reverse current	$I_S(\text{leak})$				30	μA
Forward voltage	V_{SF}	$I_{OUT} = 400\text{ mA}$			1.7	V

Note: The thermal shutdown circuit function values are design guarantees, and are not tested.

Pin Assignments

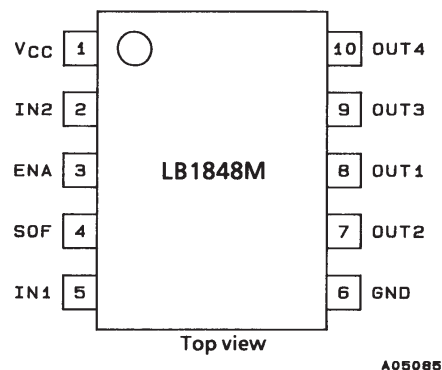
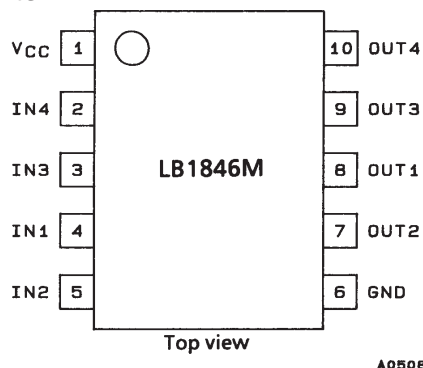

Block Diagrams

[LB1846M]

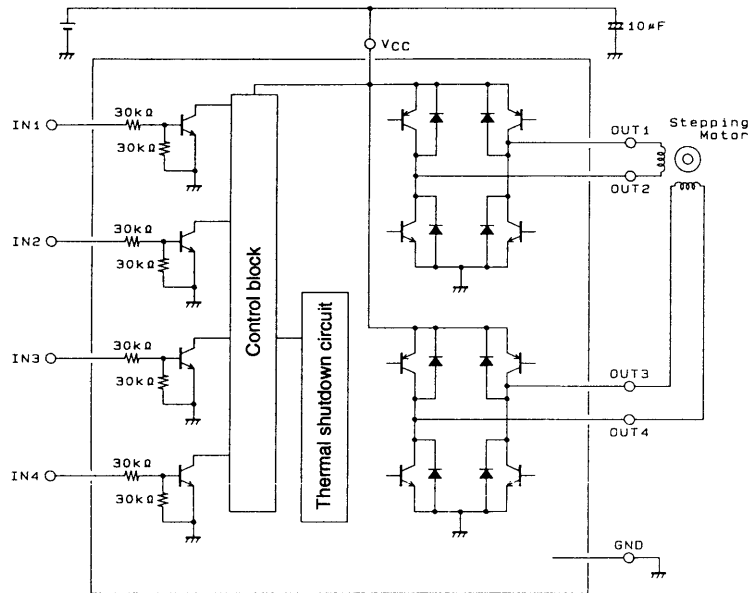

A05086

[LB1848M]

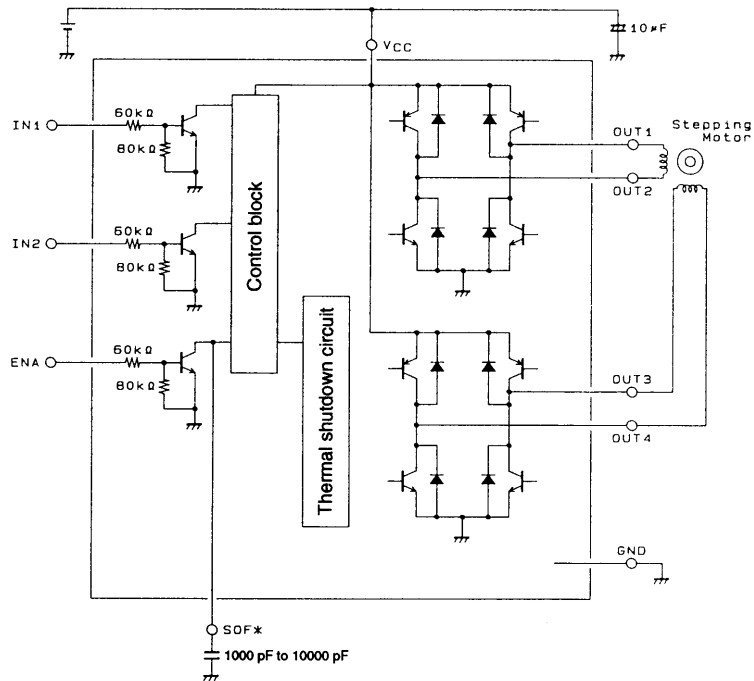

A05087

Note: When the "soft off" function is used, a capacitor must be connected to the SOF pin. If this function is not used, this pin must be left open with absolutely no signals or lines connected.

Notes on Wiring and Lines

Since large currents flow in the V_{CC} and ground lines, oscillations may occur on these lines. The following points should be observed if such oscillations occur.

- (1) Lower the line impedances by making them shorter and thicker.
- (2) Attach capacitors close to the IC.
- (3) If the controller (CPU) is mounted on a separate printed circuit board, insert series resistors (of about 10 kΩ) between the controller outputs and this IC.

LB1846M, 1848M

Truth Tables

[LB1846M]

IN1	IN2	IN3	IN4	OUT1	OUT2	OUT3	OUT4	Notes
L	L	L	L	OFF	OFF	OFF	OFF	Standby
H	L	L	L	H	L	OFF	OFF	1-2 phase excitation
H	L	H	L	H	L	H	L	
L	L	H	L	OFF	OFF	H	L	
L	H	H	L	L	H	H	L	
L	H	L	L	L	H	OFF	OFF	
L	H	L	H	L	H	L	H	
L	L	L	H	OFF	OFF	L	H	
H	L	L	H	H	L	L	H	
H	H	—	—	The logic output for the first high-level input is produced. *2				
—	—	H	H					

Note: 1. "—" indicates a "don't care" input.

2. If two high levels (H/H) are input to the IN1/IN2 pins with the timing shown in ① in the figure below, then the IN2 input that arrived later will be ignored and the IC will function as though an H/L combination is applied to the IN1/IN2 pins. Similarly, the timing shown in ② results in a L/H combination on the IN1/IN2 pins.

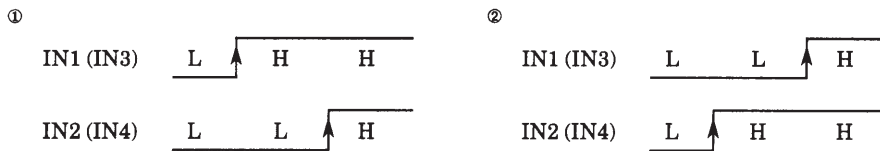

[LB1848M]

ENA	IN1	IN2	OUT1	OUT2	OUT3	OUT4	Notes
L	—	—	OFF	OFF	OFF	OFF	Standby
H	L	L	H	L	H	L	2-phase excitation
	L	H	H	L	L	H	
	H	H	L	H	L	H	
	H	L	L	H	H	L	

Note: "—" indicates a "don't care" input.

SOF Pin (“Soft Off” Function) Operation [LB1848M only]

The soft off function reduces power supply line noise due to the kickback current generated when the stepping motor drive mode is switched from drive to standby. The “soft off” function provided by this IC operates when a capacitor (0.001 to 0.01 μF) is connected between the SOF pin and ground. (Leave the SOF pin open to disable the soft off function.)

The waveforms for each pin are shown below.

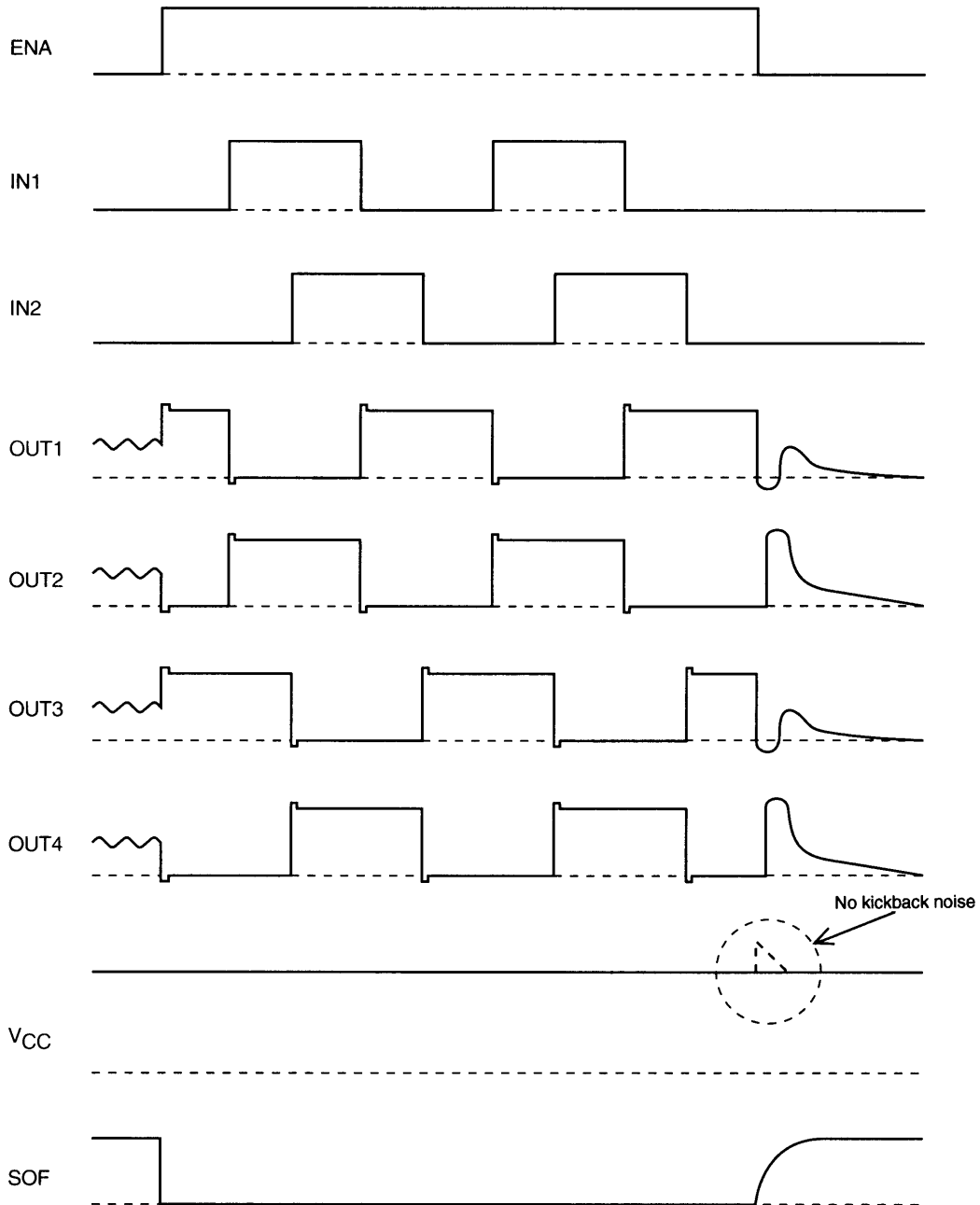

Timing Chart for Stepping Motor 2-Phase Excitation

LB1846M, 1848M

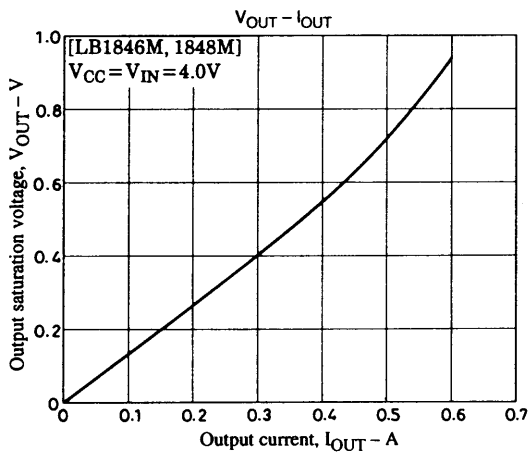
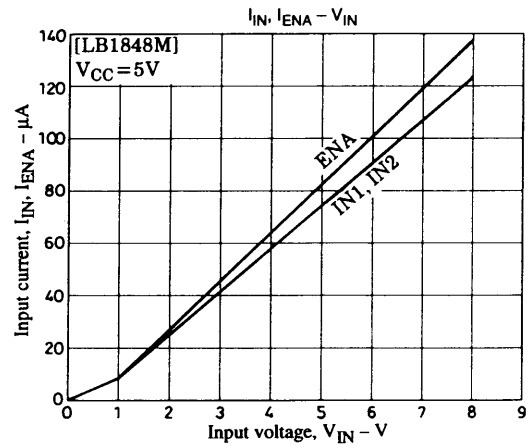
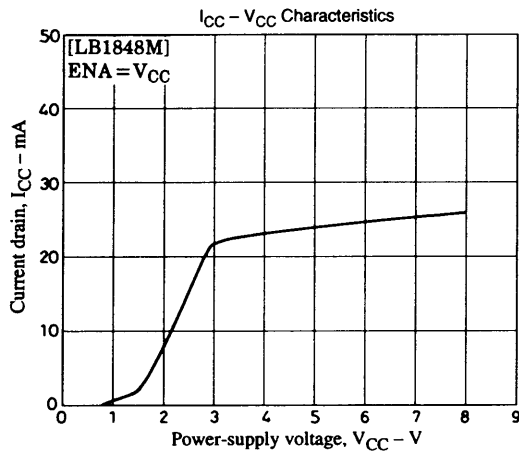
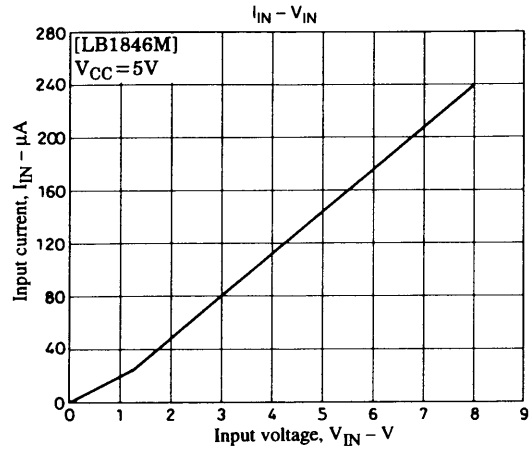
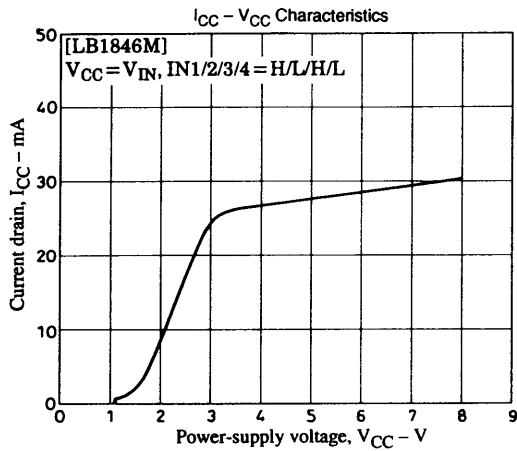

- No products described or contained herein are intended for use in surgical implants, life-support systems, aerospace equipment, nuclear power control systems, vehicles, disaster/crime-prevention equipment and the like, the failure of which may directly or indirectly cause injury, death or property loss.
- Anyone purchasing any products described or contained herein for an above-mentioned use shall:
 - ① Accept full responsibility and indemnify and defend SANYO ELECTRIC CO., LTD., its affiliates, subsidiaries and distributors and all their officers and employees, jointly and severally, against any and all claims and litigation and all damages, cost and expenses associated with such use:
 - ② Not impose any responsibility for any fault or negligence which may be cited in any such claim or litigation on SANYO ELECTRIC CO., LTD., its affiliates, subsidiaries and distributors or any of their officers and employees jointly or severally.
- Information (including circuit diagrams and circuit parameters) herein is for example only; it is not guaranteed for volume production. SANYO believes information herein is accurate and reliable, but no guarantees are made or implied regarding its use or any infringements of intellectual property rights or other rights of third parties.

This catalog provides information as of October, 1996. Specifications and information herein are subject to change without notice.