



**PCIX I/O System Clock Generator with EMI Control Features**

**Features**

- Dedicated clock buffer power pins for reduced noise, crosstalk and jitter
- Input clock frequency of 25 MHz to 33 MHz
- Output frequencies of XINx1, XINx2, XINx3 and XINx4
- One output bank of 5 clocks.
- One REF XIN clock output.
- SMBus clock control interface for individual clock disabling and SSCG control
- Output clock duty cycle is 50% ( $\pm 5\%$ )
- < 250 ps skew between output clocks within a bank
- Output jitter <175 ps
- Spread Spectrum feature for reduced electromagnetic interference (EMI)
- OE pin for entire output bank enable control and testability
- 28-pin SSOP and TSSOP packages

**Table 1. Test Mode Logic Table<sup>[1]</sup>**

Input Pins			Output Pins	
OE	S1	S0	CLK	REF
HIGH	LOW	LOW	XIN	XIN
HIGH	LOW	HIGH	2 * XIN	XIN
HIGH	HIGH	LOW	3 * XIN	XIN
HIGH	HIGH	HIGH	4 * XIN	XIN
LOW	X	X	Three-state	Three-state

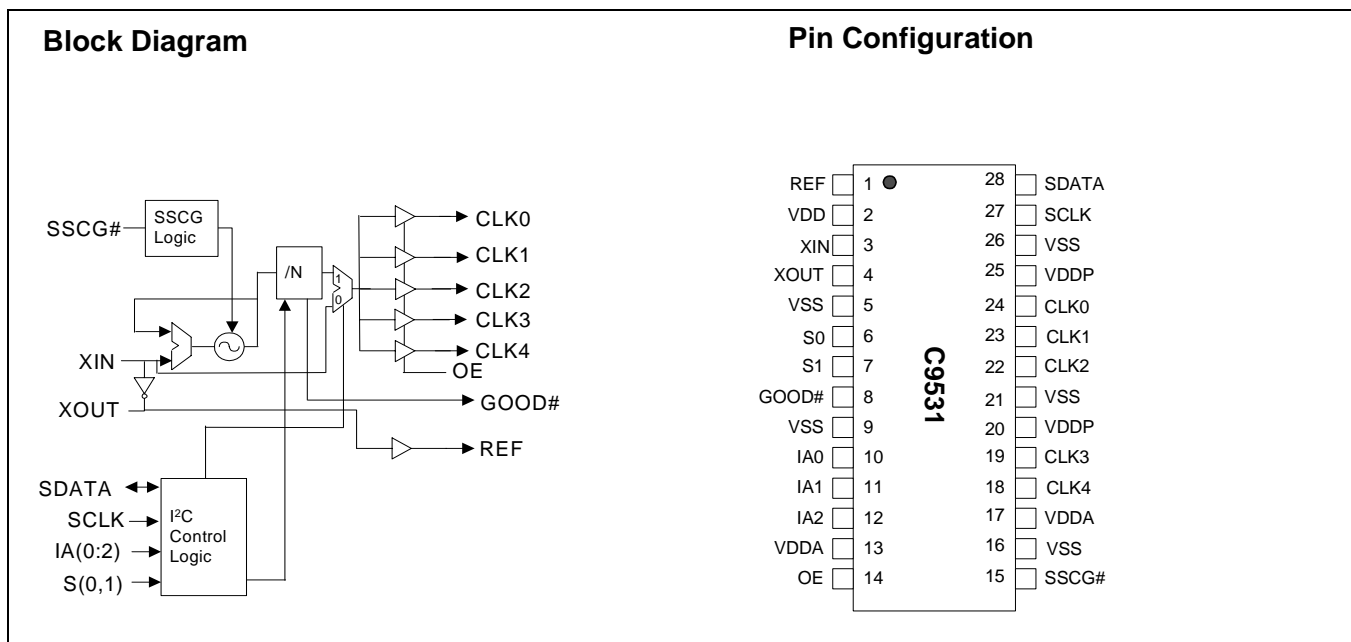

**Note:**

1. XIN is the frequency of the clock on the device's XIN pin.

**Pin Description<sup>[3]</sup>**

Pin <sup>[2]</sup>	Name	PWR <sup>[4]</sup>	I/O	Description
3	XIN	VDDA	I	<b>Crystal Buffer Input Pin.</b> Connects to a crystal, or an external clock source. Serves as input clock TCLK, in Test mode.
4	XOUT	VDDA	O	<b>Crystal Buffer Output Pin.</b> Connects to a crystal only. When a Can Oscillator is used or in test mode, this pin is kept unconnected.
1	REF	VDD	O	<b>Buffered inverted outputs of the signal applied at Xin, typically 33.33 or 25.0 MHz.</b>
14*	OE	VDD	I	<b>Output Enable for Clock Bank.</b> Causes the CLK (0:4) output clocks to be in a three-state condition when driven to a logic low level.
24, 23, 22, 19, 18	CLK(0:4)	VDDP	O	<b>A bank of five XINx1, XINx2, XINx3 and XINx4 output clocks.</b>
8	GOOD#	VDD	O	When his output signal is a logic low level, it indicates that the <b>output clocks of the bank are locked to the input reference clock.</b> This output is latched.
6*, 7*	S(0,1)	VDD	I	<b>Clock Bank Selection Bits.</b> These control the clock frequency that will be present on the outputs of the bank of buffers. See table on page one for frequency codes and selection values.
20, 25	VDDP		PWR	<b>3.3V common power supply pin for all PCI clocks CLK (0:4).</b>
10*, 11*, 12*	IA(0:2)	VDD	I	<b>SMBus Address Selection Input Pins.</b> See <i>Table 3</i> on page 3.
15*	SSCG#	VDD	I	<b>Spread Spectrum Clock Generator.</b> Enables Spread Spectrum clock modulation when at a logic low level, see Spread Spectrum Clocking on page 6.
28	SDATA	VDD	I/O	<b>Data for the Internal SMBus Circuitry.</b> See <i>Table 3</i> on page 3.
27	SCLK	VDD	I	<b>Clock for the Internal SMBus Circuitry.</b> See <i>Table 3</i> on page 3.
13, 17	VDDA		I	<b>Power for Internal Analog Circuitry.</b> This supply should have a separately decoupled current source from VDD.
2	VDD		PWR	<b>Power supply for internal core logic.</b>
5, 9, 16, 21, 26	VSS		PWR	<b>Ground pins for the device.</b>

**Notes:**

- Pin numbers ending with \* indicate that they contain device internal pull-up resistors that will insure that they are sensed as a logic 1 if no external circuitry is connected to them.
- A bypass capacitor (0.1µF) should be placed as close as possible to each V<sub>DD</sub> pin. If these bypass capacitors are not close to the pins their high frequency filtering characteristic will be cancelled by the lead inductance of the trace.
- PWR = Power connection, I = Input, O = Output and I/O = both input and output functionality of the pin(s).

**Serial Data Interface**

To enhance the flexibility and function of the clock synthesizer, a two-signal serial interface is provided. Through the Serial Data Interface, various device functions, such as individual clock output buffers, can be individually enabled or disabled. The registers associated with the Serial Data Interface initializes to their default setting upon power-up, and therefore use of this interface is optional. Clock device register changes are normally made upon system initialization, if any are required.

**Data Protocol**

The clock driver serial protocol accepts block write a operations from the controller. The bytes must be accessed in sequential order from lowest to highest byte (most significant bit first) with the ability to stop after any complete byte has been transferred. The C9531 does not support the Block Read function.

The block write protocol is outlined in *Table 2*. The addresses are listed in *Table 3*.

**Table 2. Block Read and Block Write Protocol**

Block Write Protocol	
Bit	Description
1	Start
2:8	Slave address – 7 bits
9	Write = 0
10	Acknowledge from slave
11:18	Command Code – 8 bits '00000000' stands for block operation
19	Acknowledge from slave
20:27	Byte Count – 8 bits
28	Acknowledge from slave
29:36	Data byte 1 – 8 bits
37	Acknowledge from slave
38:45	Data byte 2 – 8 bits
46	Acknowledge from slave
....	.....
....	Data Byte (N-1) – 8 bits
....	Acknowledge from slave
....	Data Byte N – 8 bits
....	Acknowledge from slave
....	Stop

**Table 3. SMBus Address Selection Table**

SMBus Address of the Device	IA0 Bit (Pin 10)	IA1 Bit (Pin 11)	IA2 Bit (Pin 12)
DE	0	0	0
DC	1	0	0
DA	0	1	0
D8	1	1	0
D6	0	0	1
D4	1	0	1
D0	0	1	1
D2	1	1	1

**Serial Control Registers**

**Byte 0: Output Register**

Bit	@Pup	Name	Description
7	1	TESTEN	Test Mode Enable. 1 = Normal operation, 0 = Test mode
6	0	SSEN	Spread Spectrum modulation control bit (effective only when Bit 0 of this register is set to a 0) 0 = OFF, 1= ON
5	1	SSSEL	SSCG Spread width select. 1 = 0.5%, 0 = 1.0% See <i>Table 4</i> below for clarification
4	0	S1	S1 Bank MSB frequency control bit (effective only when Bit 0 of this register is set to a 0)
3	0	S0	S0 Bank LSB frequency control bit (effective only when Bit 0 of this register is set to a 0)

**Byte 0: Output Register (continued)**

2	0		Not used
1	0		Not used
0	1	HWSEL	Hardware/SMBus frequency control. 1 = Hardware (pins 6, 7, and 15), 0 = SMBus Byte 0 bits 3, 4, & 6

**Table 4. Clarification Table for Byte0, bit 5**

Byte0, bit6	Byte0, bit5	Description
0	0	Frequency generated from second PLL
0	1	Frequency generated from XIN
1	0	Spread @ -1.0%
1	1	Spread @ -0.5%

**Table 5. Test Table**

Test Function Clock	Outputs		Note
	CLK	REF	
Frequency	XIN/4	XIN	XIN is the frequency of the clock that is present on the XIN input during test mode.

**Byte 1: CPU Register**

Bit	@Pup	Name	Description
7	1		Reserved
6	1		Reserved
5	1	REFEN	REF Output Enable 0 = Disable, 1= Enable
4	1		Reserved
3	1		Reserved
2	1		Reserved
1	1		Reserved
0	1		Reserved

**Byte 2: PCI Register**

Bit	@Pup	Name	Description
7	1		Reserved
6	1		Reserved
5	1		Reserved
4	1	18	CLK4 Output Enable 0 = Disable, 1= Enable
3	1	19	CLK3 Output Enable 0 = Disable, 1= Enable
2	1	22	CLK2Output Enable 0 = Disable, 1= Enable
1	1	23	CLK1 Output Enable 0 = Disable, 1= Enable
0	1	24	CLK0 Output Enable 0 = Disable, 1= Enable

### Output Clock Three-state Control

All of the clocks in the Bank may be placed in a three-state condition by bringing their relevant OE pins to a logic low state. This transition to and from a three-state and active condition is a totally asynchronous event and clock glitching may occur during the transitioning states. This function is intended as a board level testing feature. When output clocks are being enabled and disabled in active environments the SMBus control register bits are the preferred mechanism to control these signals in an orderly and predictable manner.

The output enable pin contains an internal pull-up resistor that will insure that a logic 1 is maintained and sensed by the device if no external circuitry is connected to this pin.

### Output Clock Frequency Control

All of the output clocks have their frequency selected by the logic state of the S0 and S1 control bits. The source of these

control signals is determined by the SMBus register Byte 0 bit 0. At initial power up this bit is set of a logic 1 state and thus the frequency selections are controlled by the logic levels present on the device's S(0,1) pins. If the application does not use an SMBus interface then hardware frequency selection S(0,1) must be used. If it is desired to control the output clocks using an SMBus interface, then this bit (B0b0) must first be set to a low state. After this is done the device will use the contents of the internal SMBus register Bytes 0 bits 3 and 4 to control the output clock's frequency.

The following formula and schematic may be used to understand and calculate either the loading specification of a crystal for a design or the additional discrete load capacitance that must be used to provide the correct load to a known load rated crystal.

$$C_L = \frac{(C_{XINPCB} + C_{XINFTG} + C_{XINDISC}) \times (C_{XOUTPCB} + C_{XOUTFTG}) + C_{XOUTDISC}}{(C_{XINPCB} + C_{XINFTG} + C_{XINDISC}) + (C_{XOUTPCB} + C_{XOUTFTG}) + C_{XOUTDISC}}$$

where:

$C_{XTAL}$  = The load rating of the crystal.

$C_{XINFTG}$  = The clock generators XIN pin effective device internal capacitance to ground.

$C_{XOUTFTG}$  = The clock generators XOUT pin effective device internal capacitance to ground.

$C_{XINPCB}$  = The effective capacitance to ground of the crystal to device PCB trace.

$C_{XOUTPCB}$  = The effective capacitance to ground of the crystal to device PCB trace.

$C_{XINDISC}$  = Any discrete capacitance that is placed between the XIn pin and ground.

$C_{XOUTDISC}$  = Any discrete capacitance that is placed between the XIn pin and ground.

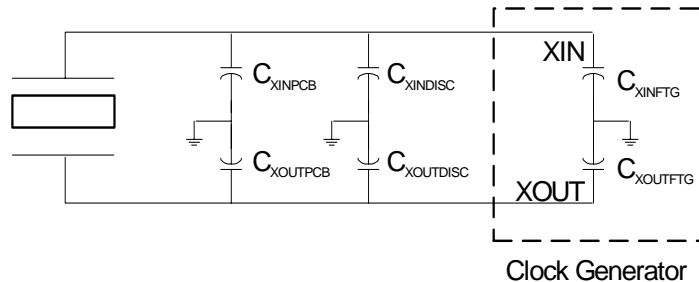

As an example and using this formula for this data sheet's device, a design that has no discrete loading capacitors ( $C_{DISC}$ ) and each of the crystal device PCB traces has a capacitance ( $C_{PCB}$ ) to ground of 4 pF (typical value) would calculate as:

$$C_L = \frac{(4 \text{ pF} + 36 \text{ pF} + 0 \text{ pF}) \times (4 \text{ pF} + 36 \text{ pF} + 0 \text{ pF})}{(4 \text{ pF} + 36 \text{ pF} + 0 \text{ pF}) + (4 \text{ pF} + 36 \text{ pF} + 0 \text{ pF})} = \frac{40 \times 40}{40 + 40} = \frac{1600}{80} = 20 \text{ pF.}$$

Therefore, to obtain output frequencies that are as close to this data sheets specified values as possible, in this design example, you should specify a parallel cut crystal that is designed to work into a load of 20 pF.

## Spread Spectrum Clocking

### Down Spread Description

Spread Spectrum is a modulation technique for distributing clock period over a certain bandwidth (called Spread Bandwidth). This technique allows the distribution of the undesirable electromagnetic energy (EMI) over a wide range of frequencies therefore reducing the average radiated energy present at any frequency over a given time period. As the spread is specified as a percentage of the resting (non-spread) frequency value, it is effective at the fundamental and, to a greater extent, at all of its harmonics.

In this device Spread Spectrum is enabled externally through pin 15 (SSCG#) or internally via SMBus Byte 0 Bit 0 and 6. Spread spectrum is enabled externally when the SSCG# pin is low. This pin has an internal device pull up resistor, which causes its state to default to a HIGH (spread spectrum modulation disabled) unless externally forced to a low. It may also be enabled by programming SMBus Byte 0 Bit 0 LOW (to enable SMBus control of the function) and then programming SMBus byte 0 bit 6 low to set the feature active.

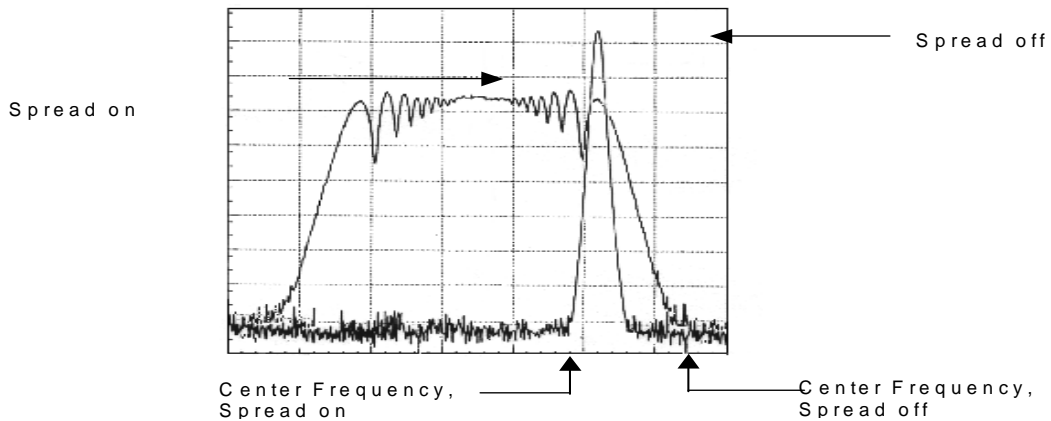

Figure 1. Spread Spectrum

Table 6. Spectrum Spreading Selection Table<sup>[5]</sup>

Output Clock Frequency	% of Frequency Spreading		Mode
	SMBus Byte 0 Bit 5 = 0	SMBus Byte 0 Bit 5 = 1	
33.3 MHz (XIN)	1.0% (-1.0% + 0%)	0.5% (-0.5% + 0%)	Down Spread
66.6 MHz (XIN*2)	1.0% (-1.0% + 0%)	0.5% (-0.5% + 0%)	Down Spread
100.0 MHz (XIN*3)	1.0% (-1.0% + 0%)	0.5% (-0.5% + 0%)	Down Spread
133.3 MHz (XIN*4)	1.0% (-1.0% + 0%)	0.5% (-0.5% + 0%)	Down Spread

**Note:**

- When SSCG is enabled, the device will down spread the clock over a range that is 1% of its resting frequency. This means that for a 100-MHz output clock frequency will sweep through a spectral range from 99 to 100 MHz.

**Absolute Maximum Conditions**

Parameter	Description	Condition	Min.	Max.	Unit
$V_{DD}, V_{DDP}$	Core Supply Voltage		-0.5	4.6	V
$V_{DDA}$	Analog Supply Voltage		-0.5	4.6	V
$V_{IN}$	Input Voltage	Relative to $V_{SS}$	-0.5	$V_{DD} + 0.5$	VDC
$T_S$	Temperature, Storage	Non Functional	-65	+150	°C
$T_A$	Temperature, Operating Ambient	Functional	0	70	°C
$T_J$	Temperature, Junction	Functional	-	150	°C
$ESD_{HBM}$	ESD Protection (Human Body Model)	MIL-STD-883, Method 3015	2000	-	V
$\theta_{JC}$	Dissipation, Junction to Case	Mil-Spec 883E Method 1012.1			°C/W
$\theta_{JA}$	Dissipation, Junction to Ambient	JEDEC (JESD 51)			°C/W
UL-94	Flammability Rating	At 1/8 in.		V-0	
MSL	Moisture Sensitivity Level			1	

**Multiple Supplies:** The voltage on any input or I/O pin cannot exceed the power pin during power-up. Power supply sequencing is NOT required.

**DC Electrical Specifications**

Parameter	Description	Condition	Min.	Max.	Unit
$V_{DD}, V_{DDP}, V_{DDA}$	3.3V Operating Voltage	$3.3V \pm 5\%$	3.135	3.465	V
$V_{IL12C}$	Input Low Voltage	SDATA, SCLK	-	1	V
$V_{IH12C}$	Input High Voltage	SDATA, SCLK	2.2	-	-
$V_{IL}$	Input Low Voltage		$V_{SS} - 0.5$	0.8	V
$V_{IH}$	Input High Voltage		2.0	$V_{DD} + 0.5$	V
$I_{IL}$	Input Leakage Current	except Pull-ups or Pull-downs $0 < V_{IN} < V_{DD}$	-5	5	$\mu A$
$V_{OL}$	Output Low Voltage	$I_{OL} = 1 \text{ mA}$	-	0.4	V
$V_{OH}$	Output High Voltage	$I_{OH} = -1 \text{ mA}$	2.4	-	V
$I_{OZ}$	High-Impedance Output Current		-10	10	$\mu A$
$C_{IN}$	Input Pin Capacitance		2	5	pF
$C_{OUT}$	Output Pin Capacitance		3	6	pF
$L_{IN}$	Pin Inductance		-	7	nH
$C_{XTAL}$	Crystal Pin Capacitance	From XIN and XOUT pins to ground	32	38	pF
$V_{XIH}$	Xin High Voltage		$0.7V_{DD}$	$V_{DD}$	V
$V_{XIL}$	Xin Low Voltage		0	$0.3V_{DD}$	V
$I_{DD}$	Dynamic Supply Current	At 133 MHz and all outputs loaded per <i>Table 7</i>	-	300	mA
$I_{PD}$	Power-down Supply Current	PD# Asserted	-	1	mA

**AC Electrical Specifications**

Parameter	Description	Condition	Min.	Max.	Unit
<b>Crystal</b>					
$T_{DC}$	XIN Duty Cycle	The device will operate reliably with input duty cycles up to 30/70%	45	55	%
$XIN_{FREQ}$	XIN Frequency	When Xin is driven from an external clock source	25	33.3	MHz
$T_R / T_F$	XIN Rise and Fall Times	Measured between $0.3V_{DD}$ and $0.7V_{DD}$	-	10.0	ns

**AC Electrical Specifications** (continued)

Parameter	Description	Condition	Min.	Max.	Unit
T <sub>CCJ</sub>	XIN Cycle to Cycle Jitter	As an average over 1μs duration	–	500	ps
L <sub>ACC</sub>	Long Term Accuracy	Over 150 ms		300	ppm
<b>CLK</b>					
T <sub>DC</sub>	CLK Duty Cycle	Measurement at 1.5V	45	55	%
T <sub>PERIOD33</sub>	33-MHz CLK Period	Measurement at 1.5V	29.5	30.5	ns
T <sub>PERIOD66</sub>	66-MHz CLK Period	Measurement at 1.5V	14.5	15.5	ns
T <sub>PERIOD100</sub>	100-MHz CLK Period	Measurement at 1.5V	9.5	10.5	ns
T <sub>PERIOD133</sub>	133-MHz CLK Period	Measurement at 1.5V	7.0	8.0	ns
T <sub>R</sub> / T <sub>F</sub>	CLK Rise and Fall Times	Measured between 0.4V and 2.4V	0.5	2.0	ns
T <sub>SKEW</sub>	Any CLK to Any CLK Clock Skew	Measurement at 1.5V	–	250	ps
T <sub>CCJ</sub>	CLK Cycle to Cycle Jitter	Measurement at 1.5V	–	175	ps
<b>REF</b>					
T <sub>DC</sub>	REF Duty Cycle	Measurement at 1.5V	45	55	%
T <sub>R</sub> / T <sub>F</sub>	REF Rise and Fall Times	Measured between 0.4V and 2.4V	1.0	4.0	ns
T <sub>CCJ</sub>	REF Cycle to Cycle Jitter	Measurement at 1.5V	–	750	ps
<b>ENABLE/DISABLE and SET-UP</b>					
tpZL, tpZH	Output Enable Delay (all outputs)		–	10.0	ns
tpLZ, tpZH	Output Disable Delay (all outputs)		–	10.0	ns
T <sub>STABLE</sub>	Clock Stabilization from Power-up		–	3.0	ms

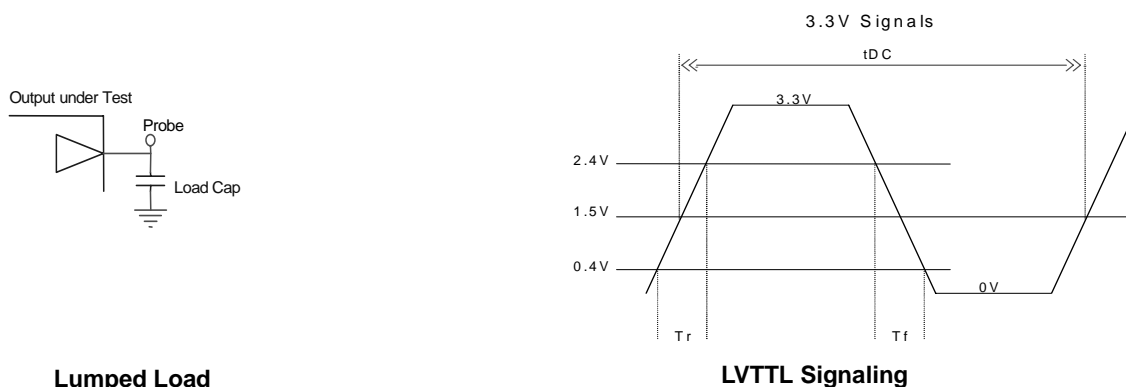
**Test and Measurement Set-up**

**Figure 2. Test and Measurement Set-up**
**Table 7. Loading**

Output Name	Max Load (in pF)
CLK	30
REF	20

**Ordering Information**

Part Number	Package Type	Product Flow
IMIC9531CY	28-Pin SSOP	Commercial, 0° to 70°C
IMIC9531CYT	28-Pin SSOP – Tape and Reel	Commercial, 0° to 70°C
IMIC9531CT	28-Pin TSSOP	Commercial, 0° to 70°C
IMIC9531CTT	28-Pin TSSOP – Tape and Reel	Commercial, 0° to 70°C



Package Drawing and Dimension

28-lead (5.3 mm) Shrunk Small Outline Package O28

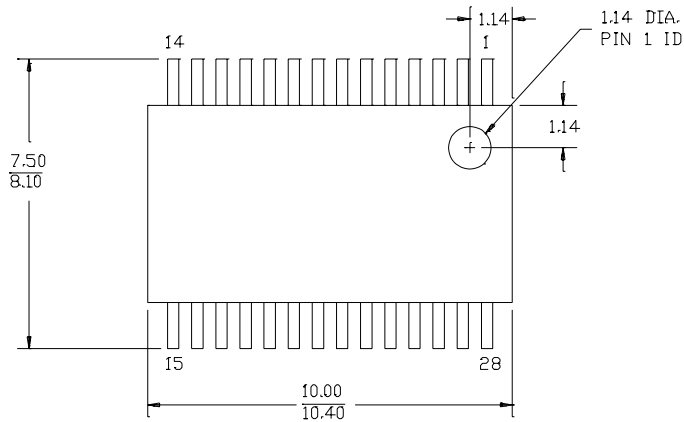

DIMENSIONS IN MILLIMETERS MIN. MAX.

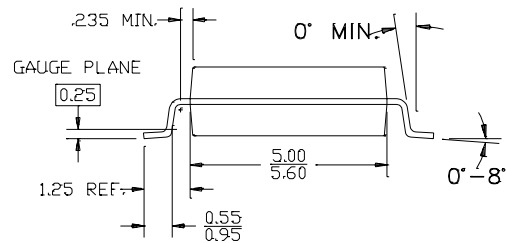
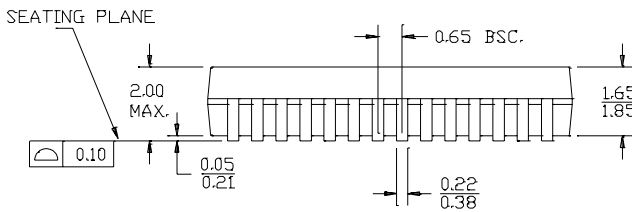

51-85079-°C

28-lead Thin Shrunk Small Outline Package (4.40-mm Body) Z29

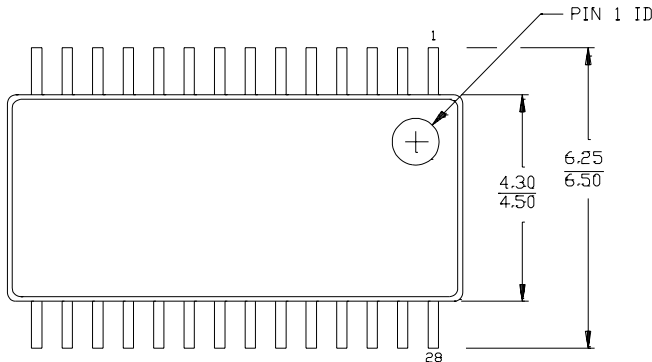

DIMENSIONS IN MILLIMETERS. MIN. MAX.

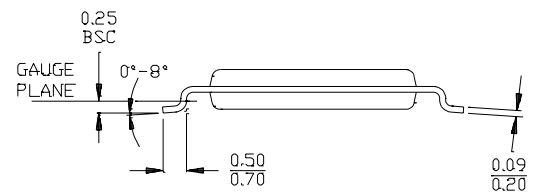
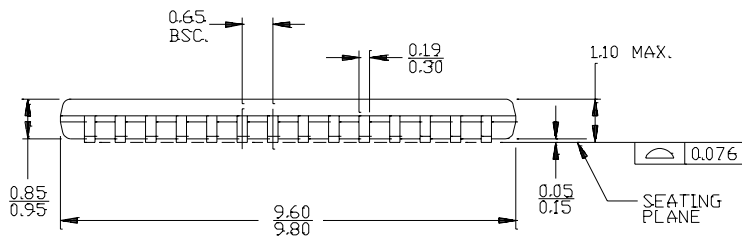

51-85120-\*\*

All product and company names mentioned in this document may be the trademarks of their respective holders.

## Document History Page

<b>Document Title: C9531 PCIX I/O System Clock Generator with EMI Control Features</b>				
<b>Document #: 38-07034</b>				
<b>REV.</b>	<b>ECN NO.</b>	<b>Issue Date</b>	<b>Orig. of Change</b>	<b>Description of Change</b>
**	106962	06/12/02	IKA	Convert from IMI to Cypress
*A	114504	08/15/02	DMG	Converted from Word to Frame Corrected Ordering Information by adding tape and reel option IMIC9531CYT and IMIC9531CTT to match the Devmaster
*B	120839	11/25/02	RGL/ DMG	Corrected the Package Drawing and Dimension from 28 TSOP to 28 TSSOP Removed the read function in the SMBus Area
*C	122727	12/14/02	RBI	Added power up requirements to maximum ratings information
*D	126597	05/14/03	RGL	Fixed DC and AC table to match characteristic data Added 25-MHz Operation