

16-BIT SINGLE-CHIP MICROCONTROLLERS

DESCRIPTION

The μ PD784214A, 784215A, 784216A, 784217A, and 784218A are products of the μ PD784216A/784218A Subseries in the 78K/IV Series. Besides a high-speed and high performance CPU, these controllers have ROM, RAM, I/O ports, 8-bit resolution A/D and D/A converters, timers, serial interfaces, a real-time output port, interrupt functions, and various other peripheral hardware.

The μ PD784214AY, 784215AY, 784216AY, 784217AY, and 784218AY are based on the μ PD784216Y/784218Y Subseries with the addition of a multimaster-supporting I²C bus interface.

The μ PD78F4218A and 78F4218AY, products with a flash memory instead of the internal ROM of mask ROM versions, and various development tools are also available.

Detailed function descriptions are provided in the following user's manuals. Be sure to read them before designing.

μ PD784216A, 784216AY Subseries User's Manual Hardware: U13570E

μ PD784218A, 784218AY Subseries User's Manual Hardware: U12970E

78K/IV Series User's Manual Instructions: U10905E

FEATURES

- 78K/IV Series
- Inherits peripheral functions of μ PD78078, 78078Y Subseries
- Minimum instruction execution time
160 ns
(@f_{xx} = 12.5 MHz operation with main system clock)
- 61 μ s
(@f_{XT} = 32.768 kHz operation with subsystem clock)
- I/O port: 86 pins
- Timer/event counter:
 - 16-bit timer/event counter \times 1 unit
 - 8-bit timer/event counter \times 6 units
- Serial interface: 3 channels
 - UART/IOE (3-wire serial I/O): 2 channels
 - CSI (3-wire serial I/O, I²C bus supporting multimaster^{Note}): 2 channels
- **Note** μ PD784216AY/784218AY Subseries only
- Supply voltage: V_{DD} = 1.8 to 5.5 V
- Standby function
HALT/STOP/IDLE mode
In low-power consumption mode: HALT/IDLE mode (with subsystem clock)
- Clock division function
- Watch timer: 1 channel
- Watchdog timer: 1 channel
- Clock output function
Selectable from f_{xx}, f_{xx}/2, f_{xx}/2², f_{xx}/2³, f_{xx}/2⁴, f_{xx}/2⁵, f_{xx}/2⁶, f_{xx}/2⁷, f_{XT}
- Buzzer output function
Selectable from f_{xx}/2¹⁰, f_{xx}/2¹¹, f_{xx}/2¹², f_{xx}/2¹³
- A/D converter: 8-bit resolution \times 8 channels
- D/A converter: 8-bit resolution \times 2 channels

APPLICATIONS

Cellular phones, PHS, cordless telephones, CD-ROM, AV equipment

Unless otherwise specified, references in this document to the μ PD784218A, 784218AY refer to the μ PD784214A, 784215A, 784216A, 784217A, 784218A, 784214AY, 784215AY, 784216AY, 784217AY, and 784218AY.

The information in this document is subject to change without notice. Before using this document, please confirm that this is the latest version.
Not all devices/types available in every country. Please check with local NEC representative for availability and additional information.

★ ORDERING INFORMATION

Part Number	Package	Internal ROM (Bytes)	Internal RAM (Bytes)
μPD784214AGC-xxx-8EU	100-pin plastic LQFP (fine pitch) (14 × 14 mm)	96 K	3,584
μPD784214AGF-xxx-3BA	100-pin plastic QFP (14 × 20 mm)	96 K	3,584
μPD784215AGC-xxx-8EU	100-pin plastic LQFP (fine pitch) (14 × 14 mm)	128 K	5,120
μPD784215AGF-xxx-3BA	100-pin plastic QFP (14 × 20 mm)	128 K	5,120
μPD784216AGC-xxx-8EU	100-pin plastic LQFP (fine pitch) (14 × 14 mm)	128 K	8,192
μPD784216AGF-xxx-3BA	100-pin plastic QFP (14 × 20 mm)	128 K	8,192
μPD784217AGC-xxx-8EU	100-pin plastic LQFP (fine pitch) (14 × 14 mm)	192 K	12,800
μPD784217AGF-xxx-3BA	100-pin plastic QFP (14 × 20 mm)	192 K	12,800
μPD784218AGC-xxx-8EU	100-pin plastic LQFP (fine pitch) (14 × 14 mm)	256 K	12,800
μPD784218AGF-xxx-3BA	100-pin plastic QFP (14 × 20 mm)	256 K	12,800
μPD784214AYGC-xxx-8EU	100-pin plastic LQFP (fine pitch) (14 × 14 mm)	96 K	3,584
μPD784214AYGF-xxx-3BA	100-pin plastic QFP (14 × 20 mm)	96 K	3,584
μPD784215AYGC-xxx-8EU	100-pin plastic LQFP (fine pitch) (14 × 14 mm)	128 K	5,120
μPD784215AYGF-xxx-3BA	100-pin plastic QFP (14 × 20 mm)	128 K	5,120
μPD784216AYGC-xxx-8EU	100-pin plastic LQFP (fine pitch) (14 × 14 mm)	128 K	8,192
μPD784216AYGF-xxx-3BA	100-pin plastic QFP (14 × 20 mm)	128 K	8,192
μPD784217AYGC-xxx-8EU	100-pin plastic LQFP (fine pitch) (14 × 14 mm)	192 K	12,800
μPD784217AYGF-xxx-3BA	100-pin plastic QFP (14 × 20 mm)	192 K	12,800
μPD784218AYGC-xxx-8EU	100-pin plastic LQFP (fine pitch) (14 × 14 mm)	256 K	12,800
μPD784218AYGF-xxx-3BA	100-pin plastic QFP (14 × 20 mm)	256 K	12,800

Remark xxx indicates ROM code suffix.

78K/IV SERIES LINEUP

: Products in mass-production

: Products under development

Standard models

μPD784026

Enhanced A/D converter, 16-bit timer, and power management

Supports I²C bus

μPD784038Y

μPD784038

Enhanced internal memory capacity
Pin-compatible with the μPD784026

Supports multimaster I²C bus

μPD784225Y

μPD784225

80-pin, ROM correction added

Supports multimaster I²C bus

μPD784216AY

μPD784216A

100-pin, enhanced I/O and internal memory capacity

Supports multimaster I²C bus

μPD784218AY

μPD784218A

Enhanced internal memory capacity, ROM correction added

μPD784054

μPD784046

On-chip 10-bit A/D converter

ASSP models

μPD784956A

For DC inverter control

μPD784908

On-chip IEBus™ controller

μPD784938A

Enhanced functions of the μPD784908, enhanced internal memory capacity, ROM correction added.

μPD784967

Enhanced functions of the μPD784938A, enhanced I/O and internal memory capacity.

Supports multimaster I²C bus

μPD784928Y

μPD784928

Enhanced functions of the μPD784915

μPD784915

Software servo control
On-chip analog circuit for VCRs
Enhanced timer

μPD784976A

On-chip VFD controller/driver

★ OVERVIEW OF FUNCTIONS (1/2)

Part Number		μPD784214A, μPD784214AY	μPD784215A, μPD784215AY	μPD784216A, μPD784216AY	μPD784217A, μPD784217AY	μPD784218A, μPD784218AY
Item						
Number of basic instructions (mnemonics)		113				
General-purpose registers		8 bits × 16 registers × 8 banks, or 16 bits × 8 registers × 8 banks (memory mapping)				
Minimum instruction execution time		<ul style="list-style-type: none"> 160 ns/320 ns/640 ns/1,280 ns/2,560 ns (@f_{xx} = 12.5 MHz operation with main system clock) 61 μs (@f_{XT} = 32.768 kHz operation with subsystem clock) 				
Internal memory	ROM	96 KB	128 KB		192 KB	256 KB
	RAM	3,584 bytes	5,120 bytes	8,192 bytes	12,800 bytes	
Memory space		1 MB with program and data spaces combined				
I/O ports	Total	86				
	CMOS input	8				
	CMOS I/O	72				
	N-ch open-drain I/O	6				
Pins with additional functions ^{Note 1}	Pins with pull-up resistor	70				
	LED direct drive output	22				
	Middle-voltage pin	6				
Real-time output port		4 bits × 2 or 8 bits × 1				
Timer/event counter		Timer/event counter: (16-bit)		Timer counter × 1 Capture/compare register × 2	Pulse output • PPG output • Square wave output • One-shot pulse output	
		Timer/event counter 1: (8-bit)		Timer counter × 1 Compare register × 1	Pulse output • PWM output • Square wave output	
		Timer/event counter 2: (8-bit)		Timer counter × 1 Compare register × 1	Pulse output • PWM output • Square wave output	
		Timer/event counter 5: (8-bit)		Timer counter × 1 Compare register × 1	Pulse output • PWM output • Square wave output	
		Timer/event counter 6: (8-bit)		Timer counter × 1 Compare register × 1	Pulse output • PWM output • Square wave output	
		Timer/event counter 7: (8-bit)		Timer counter × 1 Compare register × 1	Pulse output • PWM output • Square wave output	
		Timer/event counter 8: (8-bit)		Timer counter × 1 Compare register × 1	Pulse output • PWM output • Square wave output	
Serial interface		<ul style="list-style-type: none"> UART/IOE (3-wire serial I/O): 2 channels (on-chip baud rate generator) CSI (3-wire serial I/O, multimaster supporting I²C bus ^{Note 2}): 1 channel 				
A/D converter		8-bit resolution × 8 channels				
D/A converter		8-bit resolution × 2 channels				

- Notes** 1. Pins with additional functions are included with the I/O pins.
 2. μPD784216AY/784218AY Subseries only

OVERVIEW OF FUNCTIONS (2/2)

Part Number		μPD784214A, μPD784214AY	μPD784215A, μPD784215AY	μPD784216A, μPD784216AY	μPD784217A, μPD784217AY	μPD784218A, μPD784218AY
Item						
Clock output		Selectable from f_{xx} , $f_{xx}/2$, $f_{xx}/2^2$, $f_{xx}/2^3$, $f_{xx}/2^4$, $f_{xx}/2^5$, $f_{xx}/2^6$, $f_{xx}/2^7$, f_{XT}				
Buzzer output		Selectable from $f_{xx}/2^{10}$, $f_{xx}/2^{11}$, $f_{xx}/2^{12}$, $f_{xx}/2^{13}$				
Watch timer		1 channel				
Watchdog timer		1 channel				
Standby		<ul style="list-style-type: none"> • HALT/STOP/IDLE modes • In low power consumption mode (with subsystem clock): HALT/IDLE modes 				
Interrupt	Hardware sources	29 (internal: 20, external: 9)				
	Software sources	BRK instruction, BRKCS instruction, operand error				
	Non-maskable	Internal: 1, external: 1				
	Maskable	Internal: 19, external: 8				
		<ul style="list-style-type: none"> • 4 programmable priority levels • 3 service modes: Vectored interrupt/macro service/context switching 				
Supply voltage		$V_{DD} = 1.8$ to 5.5 V				
Package		100-pin plastic LQFP (fine pitch) (14 × 14 mm) 100-pin plastic QFP (14 × 20 mm)				

CONTENTS

- 1. DIFFERENCES AMONG MODELS IN μPD784216A, 784216AY/784218A, 784218AY SUBSERIES..... 8**
- 2. MAJOR DIFFERENCES FROM μPD78078Y SUBSERIES..... 9**
- 3. PIN CONFIGURATION (TOP VIEW)..... 10**
- 4. BLOCK DIAGRAM 13**
- 5. PIN FUNCTIONS 14**
 - 5.1 Port Pins 14**
 - 5.2 Non-Port Pins 16**
 - 5.3 Pin I/O Circuits and Recommended Connections of Unused Pins 18**
- 6. CPU ARCHITECTURE 22**
 - 6.1 Memory Space 22**
 - 6.2 CPU Registers..... 29**
 - 6.2.1 General-purpose registers 29
 - 6.2.2 Control registers..... 30
 - 6.2.3 Special function registers (SFRs)..... 31
- 7. PERIPHERAL HARDWARE FUNCTIONS..... 36**
 - 7.1 Ports 36**
 - 7.2 Clock Generator..... 37**
 - 7.3 Real-Time Output Port 39**
 - 7.4 Timer/Event Counter 40**
 - 7.5 A/D Converter 42**
 - 7.6 D/A Converter 43**
 - 7.7 Serial Interface..... 44**
 - 7.7.1 Asynchronous serial interface/3-wire serial I/O (UART/IOE) 45
 - 7.7.2 Clocked serial interface (CSI) 47
 - 7.8 Clock Output Function..... 49**
 - 7.9 Buzzer Output Function..... 49**
 - 7.10 Edge Detection Function 50**
 - 7.11 Watch Timer 50**
 - 7.12 Watchdog Timer 51**
- 8. INTERRUPT FUNCTIONS..... 52**
 - 8.1 Interrupt Sources..... 52**
 - 8.2 Vectored Interrupt 54**
 - 8.3 Context Switching 55**
 - 8.4 Macro Service 56**
 - 8.5 Application Example of Macro Service 57**

9. LOCAL BUS INTERFACE.....	58
9.1 Memory Expansion	59
9.2 Programmable Wait	59
10. STANDBY FUNCTION.....	60
11. RESET FUNCTION	62
12. INSTRUCTION SET	63
13. ELECTRICAL SPECIFICATIONS.....	68
14. PACKAGE DRAWINGS.....	88
15. RECOMMENDED SOLDERING CONDITIONS.....	90
APPENDIX A. DEVELOPMENT TOOLS.....	92
APPENDIX B. RELATED DOCUMENTS.....	95

★1. DIFFERENCES AMONG MODELS IN μPD784216A, 784216AY/784218A, 784218AY SUBSERIES

The only difference among the μPD784214A, 784215A, 784216A, 784217A, and 784218A lies in the internal memory capacity.

The μPD784214AY, 784215AY, 784216AY, 784217AY, and 784218AY are models with the addition of an I²C bus control function.

The μPD78F4216A, 78F4216AY, 78F4218A, and 78F4218AY are provided with a 128 KB/256 KB flash memory instead of the mask ROM of the above models.

These differences are summarized in Table 1-1.

Table 1-1. Differences Among Models in μPD784216A, 784216AY/784218A, 784218AY Subseries

Part Number	μPD784214A, μPD784214AY	μPD784215A, μPD784215AY	μPD784216A, μPD784216AY	μPD784217A, μPD784217AY	μPD784218A, μPD784218AY	μPD78F4216A, μPD78F4216AY	μPD78F4218A, μPD78F4218AY
Internal ROM	96 KB (Mask ROM)	128 KB (Mask ROM)		192 KB (Mask ROM)	256 KB (Mask ROM)	128 KB (Flash memory)	256 KB (Flash memory)
Internal RAM	3,584 bytes	5,120 bytes	8,192 bytes	12,800 bytes		5,120 bytes	12,800 bytes
Internal memory size switching register (IMS)	Not provided					Provided ^{Note}	
ROM correction	Not provided			Provided		Not provided	Provided
External access status function	Not provided			Provided		Not provided	Provided
Supply voltage	V _{DD} = 1.8 to 5.5 V					V _{DD} = 1.9 to 5.5 V	
Electrical specifications	Refer to the data sheet for each device.						
Recommended soldering conditions							
EXA pin	Not provided			Provided		Not provided	Provided
TEST pin	Provided					Not provided	
V _{PP} pin	Not provided					Provided	

Note The internal flash memory capacity and internal RAM capacity can be changed using the internal memory size switching register (IMS).

Caution There are differences in noise immunity and noise radiation between the flash memory and mask ROM versions. When pre-producing an application set with the flash memory version and then mass-producing it with the mask ROM version, be sure to conduct sufficient evaluations on the commercial samples (not engineering samples) of the mask ROM version.

2. MAJOR DIFFERENCES FROM μPD78078Y SUBSERIES

Item		Series Name	μPD784216A, 784216AY/784218A, 784218AY Subseries	μPD78078Y Subseries
CPU			16-bit CPU	8-bit CPU
Minimum instruction execution time	With main system clock		160 ns (@12.5 MHz operation)	400 ns (@5.0 MHz operation)
	With subsystem clock		61 μs (@32.768 kHz operation)	122 μs (@32.768 kHz operation)
Memory space			1 MB	64 KB
I/O ports	Total		86	88
	CMOS input		8	2
	CMOS I/O		72	78
	N-ch open-drain I/O		6	8
Pins with additional functions ^{Note 1}	Pins with pull-up resistor		70	86
	LED direct drive output		22	16
	Middle-voltage pin		6	8
Timer/counter			<ul style="list-style-type: none"> • 16-bit timer/event counter × 1 unit • 8-bit timer/event counter × 6 units 	<ul style="list-style-type: none"> • 16-bit timer/event counter × 1 unit • 8-bit timer/event counter × 4 units
Serial interface			<ul style="list-style-type: none"> • UART/IOE (3-wire serial I/O) × 2 channels • CSI (3-wire serial I/O, multimaster supporting I²C bus^{Note 2}) × 1 channel 	<ul style="list-style-type: none"> • UART/IOE (3-wire serial I/O) × 1 channel • CSI (3-wire serial I/O, 2-wire serial I/O, I²C bus) × 1 channel • CSI (3-wire serial I/O, 3-wire serial I/O with automatic transmit/receive function) × 1 channel
Interrupts	NMI pin		Provided	Not provided
	Macro service		Provided	Not provided
	Context switching		Provided	Not provided
	Programmable priority		4 levels	Not provided
Standby function			<ul style="list-style-type: none"> • HALT/STOP/IDLE modes • In low power consumption mode: HALT/IDLE modes 	HALT/STOP modes
Package			<ul style="list-style-type: none"> • 100-pin plastic LQFP (fine pitch) (14 × 14 mm) • 100-pin plastic QFP (14 × 20 mm) 	<ul style="list-style-type: none"> • 100-pin plastic LQFP (fine pitch) (14 × 14 mm) • 100-pin plastic QFP (14 × 20 mm) • 100-pin ceramic WQFN (14 × 20 mm) (μPD78P078Y only)

Notes 1. Pins with additional functions are included with the I/O pins.

2. μPD784216AY/784218AY Subseries only

★3. PIN CONFIGURATION (TOP VIEW)

• 100-pin plastic LQFP (fine pitch) (14 × 14 mm)

μPD784214AGC-xxx-8EU, μPD784215AGC-xxx-8EU, μPD784216AGC-xxx-8EU, μPD784217AGC-xxx-8EU,
 μPD784218AGC-xxx-8EU, μPD784214AYGC-xxx-8EU, μPD784215AYGC-xxx-8EU,
 μPD784216AYGC-xxx-8EU, μPD784217AYGC-xxx-8EU, μPD784218AYGC-xxx-8EU

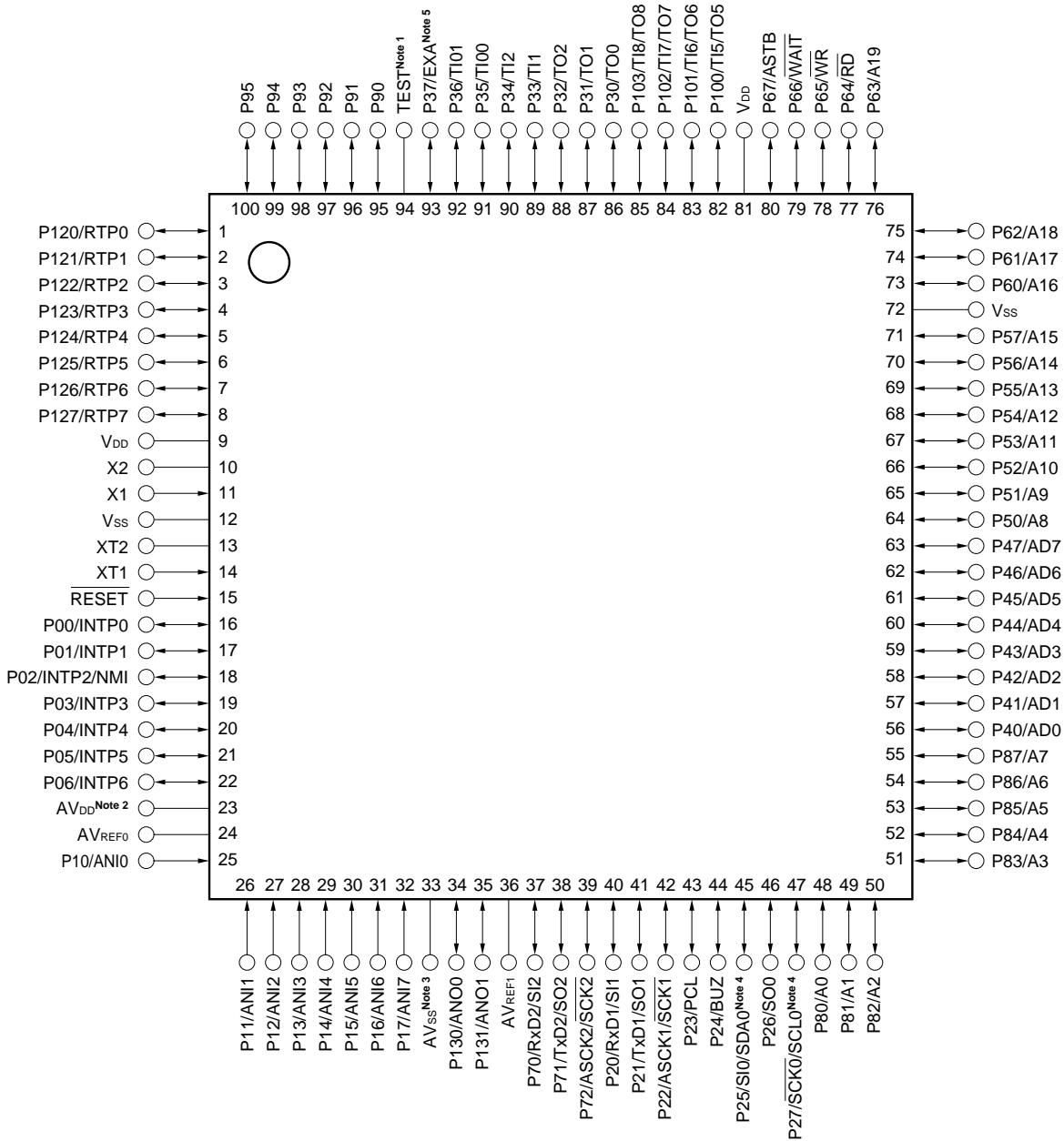

- Notes**
1. Connect the TEST pin to V_{SS} directly or via a pull-down resistor. For the pull-down connection, it is recommended to use a resistor with a resistance ranging from 470 Ω to 10 kΩ.
 2. Connect the AV_{DD} pin to V_{DD}.
 3. Connect the AV_{SS} pin to V_{SS}.
 4. The SCL0 and SDA0 pins are available in μPD784216AY/784218AY Subseries products only.
 5. The EXA pin is available in μPD784218A, 784218AY Subseries products only.

• 100-pin plastic QFP (14 × 20 mm)

μPD784214AGF-xxx-3BA, μPD784215AGF-xxx-3BA, μPD784216AGF-xxx-3BA, μPD784217AGF-xxx-3BA,
 μPD784218AGF-xxx-3BA, μPD784214AYGF-xxx-3BA, μPD784215AYGF-xxx-3BA,
 μPD784216AYGF-xxx-3BA, μPD784217AYGF-xxx-3BA, μPD784218AYGF-xxx-3BA

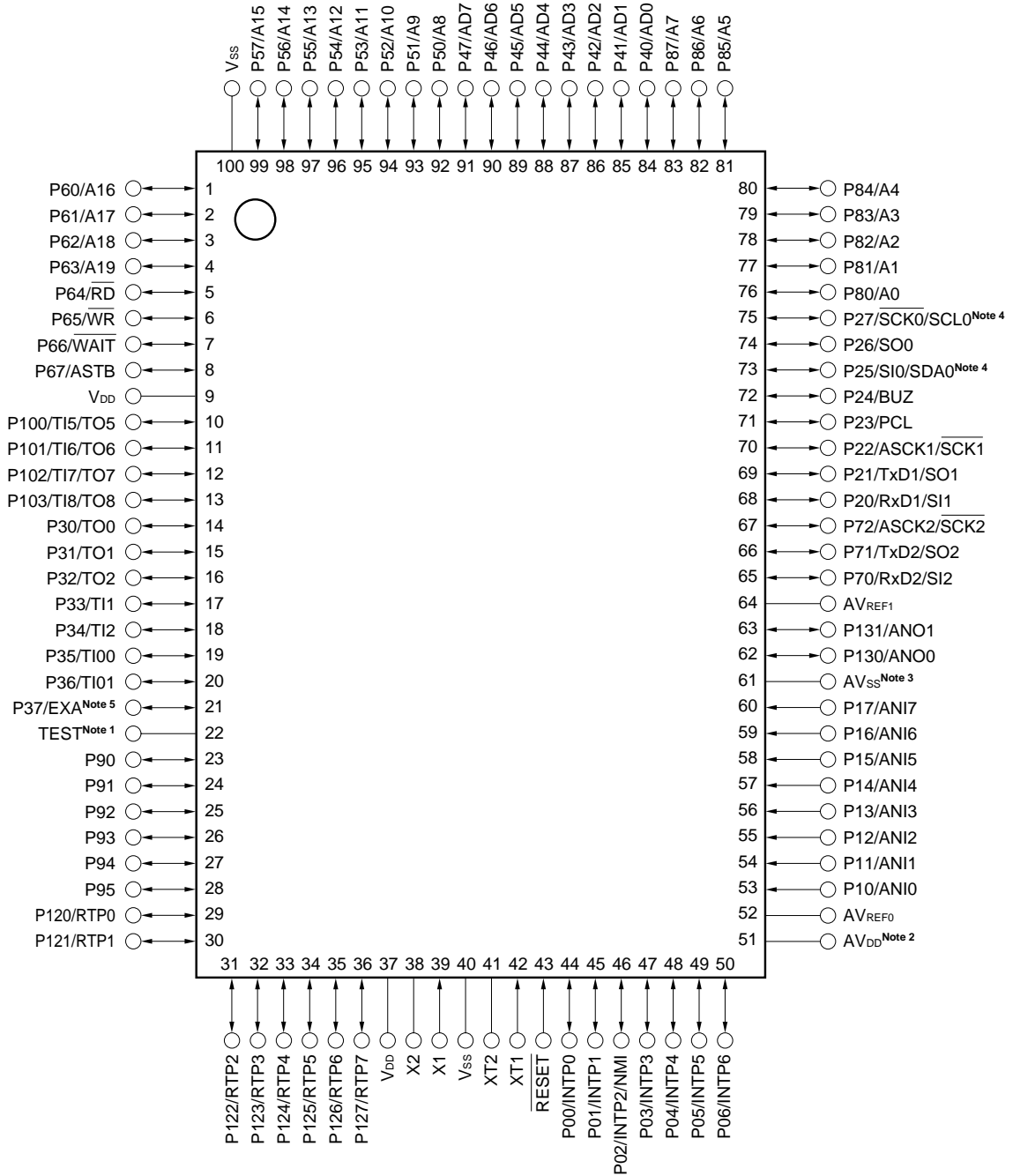

- Notes**
1. Connect the TEST pin to V_{SS} directly or via a pull-down resistor. For the pull-down connection, it is recommended to use a resistor with a resistance ranging from 470 Ω to 10 kΩ.
 2. Connect the AV_{DD} pin to V_{DD}.
 3. Connect the AV_{SS} pin to V_{SS}.
 4. The SCL0 and SDA0 pins are available in μPD784216AY/784218AY Subseries products only.
 5. The EXA pin is available in μPD784218A, 784218AY Subseries products only.

A0 to A19:	Address Bus	P120 to P127:	Port 12
AD0 to AD7:	Address/Data Bus	P130, P131:	Port 13
ANI0 to ANI7:	Analog Input	PCL:	Programmable Clock
ANO0, ANO1:	Analog Output	\overline{RD} :	Read Strobe
ASCK1, ASCK2:	Asynchronous Serial Clock	\overline{RESET} :	Reset
ASTB:	Address Strobe	RTP0 to RTP7:	Real-time Output Port
AV _{DD} :	Analog Power Supply	RxD1, RxD2:	Receive Data
AV _{REF0} , AV _{REF1} :	Analog Reference Voltage	$\overline{SCK0}$ to $\overline{SCK2}$:	Serial Clock
AV _{SS} :	Analog Ground	SCL0 ^{Note 1} :	Serial Clock
BUZ:	Buzzer Clock	SDA0 ^{Note 1} :	Serial Data
EXA ^{Note 2} :	External Access Status Output	SI0 to SI2:	Serial Input
INTP0 to INTP6:	Interrupt from Peripherals	SO0 to SO2:	Serial Output
NMI:	Non-maskable Interrupt	TEST:	Test
P00 to P06:	Port 0	TI00, TI01,	
P10 to P17:	Port 1	TI1, TI2, TI5 to TI8:	Timer Input
P20 to P27:	Port 2	TO0 to TO2, TO5 to TO8:	Timer Output
P30 to P37:	Port 3	TxD1, TxD2:	Transmit Data
P40 to P47:	Port 4	V _{DD} :	Power Supply
P50 to P57:	Port 5	V _{SS} :	Ground
P60 to P67:	Port 6	\overline{WAIT} :	Wait
P70 to P72:	Port 7	\overline{WR} :	Write Strobe
P80 to P87:	Port 8	X1, X2:	Crystal (Main System Clock)
P90 to P95:	Port 9	XT1, XT2:	Crystal (Subsystem Clock)
P100 to P103:	Port 10		

Notes 1. The SCL0 and SDA0 pins are available in μPD784216AY/784218AY Subseries products only.

2. The EXA pin is available in μPD784218A, 784218AY Subseries products only.

4. BLOCK DIAGRAM

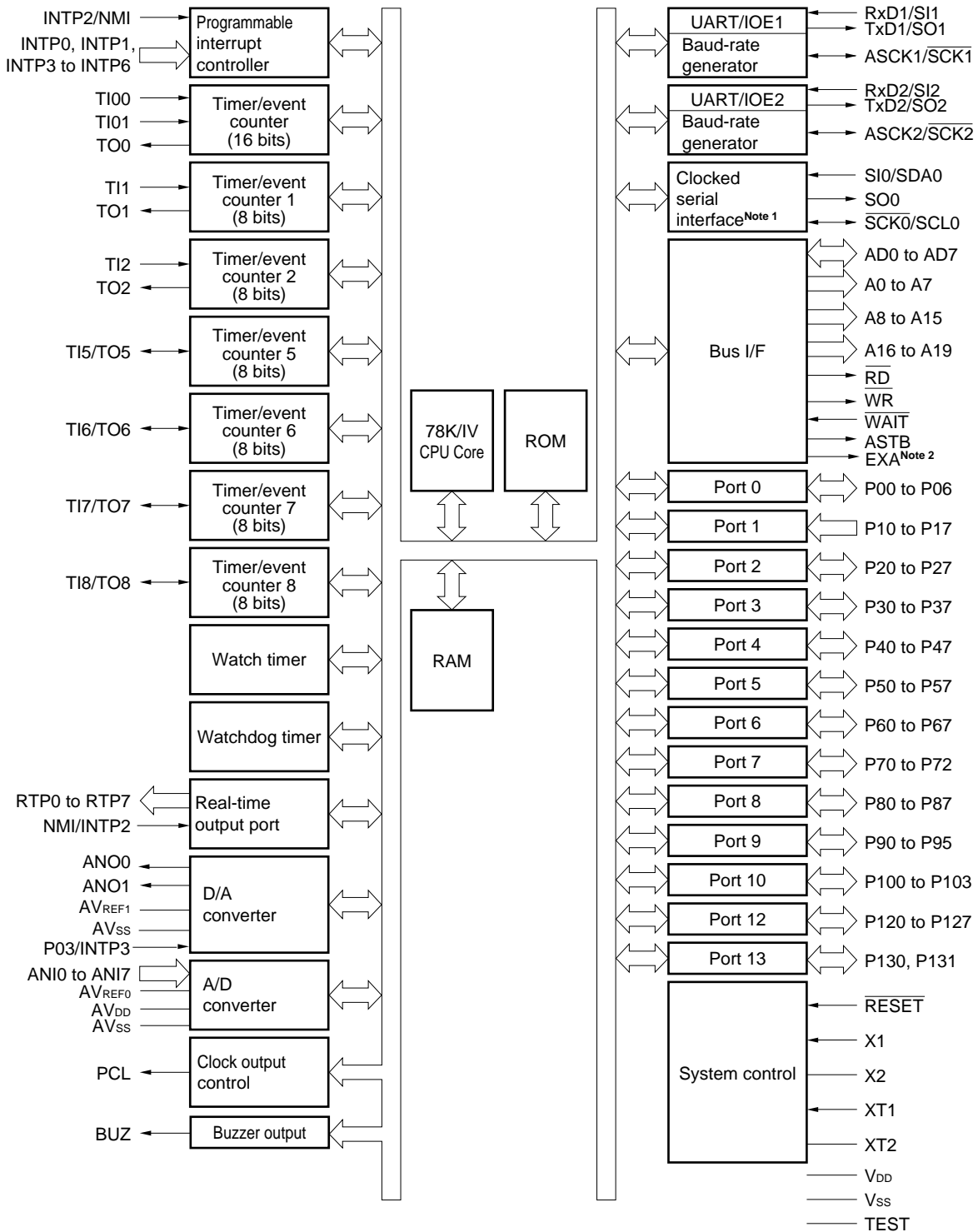

Notes 1. This function supports the I²C bus interface and is available in μPD784216AY/784218AY Subseries products only.

2. The EXA pin is available in μPD784218A, 784218AY Subseries products only.

Remark The internal ROM and RAM capacities differ depending on the product.

5. PIN FUNCTIONS

5.1 Port Pins (1/2)

Pin Name	I/O	Alternate Function	Function
P00	I/O	INTP0	Port 0 (P0): <ul style="list-style-type: none"> • 7-bit I/O port • Input/output can be specified in 1-bit units. • Whether specifying input mode or output mode, use of an on-chip pull-up resistor can be specified in 1-bit units by means of software.
P01		INTP1	
P02		INTP2/NMI	
P03		INTP3	
P04		INTP4	
P05		INTP5	
P06		INTP6	
P10 to P17	Input	ANI0 to ANI7	Port 1 (P1): <ul style="list-style-type: none"> • 8-bit input only port
P20	I/O	RxD1/SI1	Port 2 (P2): <ul style="list-style-type: none"> • 8-bit I/O port • Input/output can be specified in 1-bit units. • Whether specifying input mode or output mode, use of an on-chip pull-up resistor can be specified in 1-bit units by means of software.
P21		TxD1/SO1	
P22		ASCK1/ $\overline{\text{SCK1}}$	
P23		PCL	
P24		BUZ	
P25		SI0/SDA0 ^{Note 1}	
P26		SO0	
P27		$\overline{\text{SCK0}}$ /SCL0 ^{Note 1}	
P30	I/O	TO0	Port 3 (P3): <ul style="list-style-type: none"> • 8-bit I/O port • Input/output can be specified in 1-bit units. • Whether specifying input mode or output mode, use of an on-chip pull-up resistor can be specified in 1-bit units by means of software.
P31		TO1	
P32		TO2	
P33		TI1	
P34		TI2	
P35		TI00	
P36		TI01	
P37		EXA ^{Note 2}	
P40 to P47	I/O	AD0 to AD7	Port 4 (P4): <ul style="list-style-type: none"> • 8-bit I/O port • Input/output can be specified in 1-bit units. • All pins set in input mode can be connected to on-chip pull-up resistors by means of software. • LEDs can be driven directly.
P50 to P57	I/O	A8 to A15	Port 5 (P5): <ul style="list-style-type: none"> • 8-bit I/O port • Input/output can be specified in 1-bit units. • All pins set in input mode can be connected to on-chip pull-up resistors by means of software. • LEDs can be driven directly.

Notes 1. This function is available in μPD784216AY/784218AY Subseries products only.
 2. This function is available in μPD784218A, 784218AY Subseries products only.

5.1 Port Pins (2/2)

Pin Name	I/O	Alternate Function	Function
P60	I/O	A16	Port 6 (P6): <ul style="list-style-type: none"> • 8-bit I/O port • Input/output can be specified in 1-bit units. • All pins set in input mode can be connected to on-chip pull-up resistors by means of software.
P61		A17	
P62		A18	
P63		A19	
P64		\overline{RD}	
P65		\overline{WR}	
P66		\overline{WAIT}	
P67		ASTB	
P70	I/O	RxD2/SI2	Port 7 (P7): <ul style="list-style-type: none"> • 3-bit I/O port • Input/output can be specified in 1-bit units. • Whether specifying input mode or output mode, use of an on-chip pull-up resistor can be specified in 1-bit units by means of software.
P71		TxD2/SO2	
P72		ASCK2/ $\overline{SCK2}$	
P80 to P87	I/O	A0 to A7	Port 8 (P8): <ul style="list-style-type: none"> • 8-bit I/O port • Input/output can be specified in 1-bit units. • Whether specifying input mode or output mode, use of an on-chip pull-up resistor can be specified in 1-bit units by means of software. • The interrupt control flag (KRIF) is set to 1 when a falling edge is detected at a pin of this port.
P90 to P95	I/O	–	Port 9 (P9): <ul style="list-style-type: none"> • N-ch open-drain middle-voltage I/O port • 6-bit I/O port • Input/output can be specified in 1-bit units. • LEDs can be driven directly.
P100	I/O	TI5/TO5	Port 10 (P10): <ul style="list-style-type: none"> • 4-bit I/O port • Input/output can be specified in 1-bit units. • Whether specifying input mode or output mode, use of an on-chip pull-up resistor can be specified in 1-bit units by means of software.
P101		TI6/TO6	
P102		TI7/TO7	
P103		TI8/TO8	
P120 to P127	I/O	RTP0 to RTP7	Port 12 (P12): <ul style="list-style-type: none"> • 8-bit I/O port • Input/output can be specified in 1-bit units. • Whether specifying input mode or output mode, use of an on-chip pull-up resistor can be specified in 1-bit units by means of software.
P130, P131	I/O	ANO0, ANO1	Port 13 (P13): <ul style="list-style-type: none"> • 2-bit I/O port • Input/output can be specified in 1-bit units.

5.2 Non-Port Pins (1/2)

Pin Name	I/O	Alternate Function	Function
TI00	Input	P35	External count clock input to 16-bit timer counter
TI01		P36	Capture trigger signal input to capture/compare register 00
TI1		P33	External count clock input to 8-bit timer counter 1
TI2		P34	External count clock input to 8-bit timer counter 2
TI5		P100/TO5	External count clock input to 8-bit timer counter 5
TI6		P101/TO6	External count clock input to 8-bit timer counter 6
TI7		P102/TO7	External count clock input to 8-bit timer counter 7
TI8		P103/TO8	External count clock input to 8-bit timer counter 8
TO0	Output	P30	16-bit timer output (shared by 14-bit PWM output)
TO1		P31	8-bit timer output (shared by 8-bit PWM output)
TO2		P32	
TO5		P100/TI5	
TO6		P101/TI6	
TO7		P102/TI7	
TO8		P103/TI8	
RxD1	Input	P20/SI1	Serial data input (UART1)
RxD2		P70/SI2	Serial data input (UART2)
TxD1	Output	P21/SO1	Serial data output (UART1)
TxD2		P71/SO2	Serial data output (UART2)
ASCK1	Input	P22/ $\overline{\text{SCK}}1$	Baud rate clock input (UART1)
ASCK2		P72/ $\overline{\text{SCK}}2$	Baud rate clock input (UART2)
SI0	Input	P25/SDA0 ^{Note}	Serial data input (3-wire serial I/O 0)
SI1		P20/RxD1	Serial data input (3-wire serial I/O 1)
SI2		P70/RxD2	Serial data input (3-wire serial I/O 2)
SO0	Output	P26	Serial data output (3-wire serial I/O 0)
SO1		P21/TxD1	Serial data output (3-wire serial I/O 1)
SO2		P71/TxD2	Serial data output (3-wire serial I/O 2)
SDA0	I/O	P25/SI0	Serial data input/output (I ² C bus)
$\overline{\text{SCK}}0$		P27/SCL0 ^{Note}	Serial clock input/output (3-wire serial I/O 0)
$\overline{\text{SCK}}1$		P22/ASCK1	Serial clock input/output (3-wire serial I/O 1)
$\overline{\text{SCK}}2$		P72/ASCK2	Serial clock input/output (3-wire serial I/O 2)
SCL0		P27/ $\overline{\text{SCK}}0$	Serial clock input/output (I ² C bus)
NMI	Input	P02/INTP2	Non-maskable interrupt request input
INTP0		P00	External interrupt request input
INTP1		P01	
INTP2		P02/NMI	
INTP3		P03	
INTP4		P04	
INTP5		P05	
INTP6	P06		

Note This function is available in μPD784216AY/784218AY Subseries products only.

5.2 Non-Port Pins (2/2)

Pin Name	I/O	Alternate Function	Function
PCL	Output	P23	Clock output (for trimming main system clock and subsystem clock)
BUZ	Output	P24	Buzzer output
RTP0 to RTP7	Output	P120 to P127	Real-time output port that outputs data in synchronization with trigger
AD0 to AD7	I/O	P40 to P47	Lower address/data bus for expanding memory externally
A0 to A7	Output	P80 to P87	Lower address bus for expanding memory externally
A8 to A15		P50 to P57	Middle address bus for expanding memory externally
A16 to A19		P60 to P63	Higher address bus for expanding memory externally
\overline{RD}	Output	P64	Strobe signal output for reading from external memory
\overline{WR}		P65	Strobe signal output for writing to external memory
\overline{WAIT}	Input	P66	Wait insertion at external memory access
ASTB	Output	P67	Strobe output that externally latches address information output to ports 4 through 6 and 8 to access external memory
EXA ^{Note}	Output	P37	Status signal output at external memory access
\overline{RESET}	Input	–	System reset input
X1	Input	–	Connecting crystal resonator for main system clock oscillation
X2	–		
XT1	Input	–	Connecting crystal resonator for subsystem clock oscillation
XT2	–		
ANI0 to ANI7	Input	P10 to P17	A/D converter analog input
ANO0, ANO1	Output	P130, P131	D/A converter analog output
AVREF0	–	–	A/D converter reference voltage input
AVREF1			D/A converter reference voltage input
AVDD			A/D converter positive power supply. Connect to V _{DD} .
AVSS			GND for A/D converter and D/A converter. Connect to V _{SS} .
VDD			Positive power supply
VSS			GND
TEST			Connect this pin to V _{SS} directly or via a pull-down resistor. For the pull-down connection, it is recommended to use a resistor with a resistance ranging from 470 Ω to 10 kΩ (this pin is for IC test).

Note This function is available in μPD784218A, 784218AY Subseries products only.

5.3 Pin I/O Circuits and Recommended Connections of Unused Pins

The input/output circuit type of each pin and recommended connections of unused pins are shown in Table 5-1. For each type of input/output circuit, refer to Figure 5-1.

Table 5-1. Types of Pin Input/Output Circuits and Recommended Connection of Unused Pins (1/2)

Pin Name	I/O Circuit Type	I/O	Recommended Connection of Unused Pins
P00/INTP0	8-N	I/O	Input: Independently connect to V _{SS} via a resistor Output: Leave open
P01/INTP1			
P02/INTP2/NMI			
P03/INTP3 to P06/INTP6			
P10/ANI0 to P17/ANI7	9	Input	Connect to V _{SS} or V _{DD}
P20/RxD1/SI1	10-K	I/O	Input: Independently connect to V _{SS} via a resistor Output: Leave open
P21/TxD1/SO1	10-L		
P22/ASCK1/SCK1	10-K		
P23/PCL	10-L		
P24/BUZ			
P25/SI0/SDA0 ^{Note 1}	10-K		
P26/SO0	10-L		
P27/SCK0/SCL0 ^{Note 1}	10-K		
P30/TO0 to P32/TO2	12-E		
P33/TI1, P34/TI2	8-N		
P35/TI00, P36/TI01	10-M		
P37/EXA ^{Note 2}	12-E		
P40/AD0 to P47/AD7	5-A		
P50/A8 to P57/A15			
P60/A16 to P63/A19			
P64/RD			
P65/WR			
P66/WAIT			
P67/ASTB			
P70/RxD2/SI2	8-N		
P71/TxD2/SO2	10-M		
P72/ASCK2/SCK2	8-N		
P80/A0 to P87/A7	12-E		
P90 to P95	13-D		
P100/TI5/TO5	8-N		
P101/TI6/TO6			
P102/TI7/TO7			
P103/TI8/TO8			
P120/RTP0 to P127/RTP7	12-E		
P130/ANO0, P131/ANO1	12-F		

Notes 1. This function is available in μPD784216AY/784218AY Subseries products only.
2. This function is available in μPD784218A, 784218AY Subseries products only.

Table 5-1. Types of Pin Input/Output Circuits and Recommended Connection of Unused Pins (2/2)

Pin Name	I/O Circuit Type	I/O	Recommended Connection of Unused Pins
RESET	2-G	Input	–
XT1	16	–	Connect to V _{SS}
XT2			Leave open
AV _{REF0}	–	–	Connect to V _{SS}
AV _{REF1}			Connect to V _{DD}
AV _{DD}			
AV _{SS}			Connect to V _{SS}
TEST			Connect this pin to V _{SS} directly or via a pull-down resistor. For the pull-down connection, it is recommended to use a resistor with a resistance ranging from 470 Ω to 10 kΩ.

Remark Because the circuit type numbers are standardized among the 78K Series products, they are not sequential in some models (i.e., some circuits are not provided).

Figure 5-1. Types of Pin I/O Circuits (1/2)

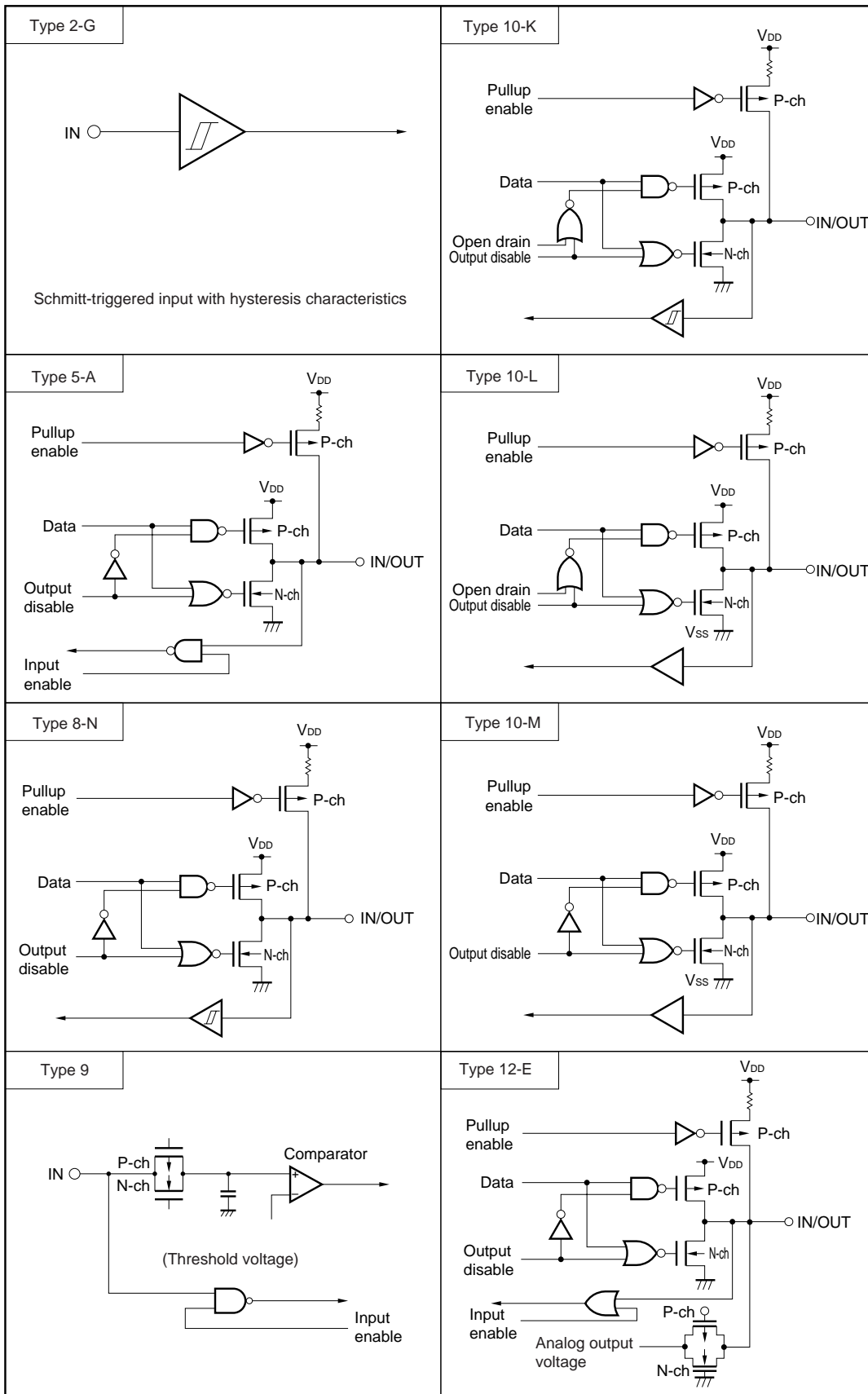
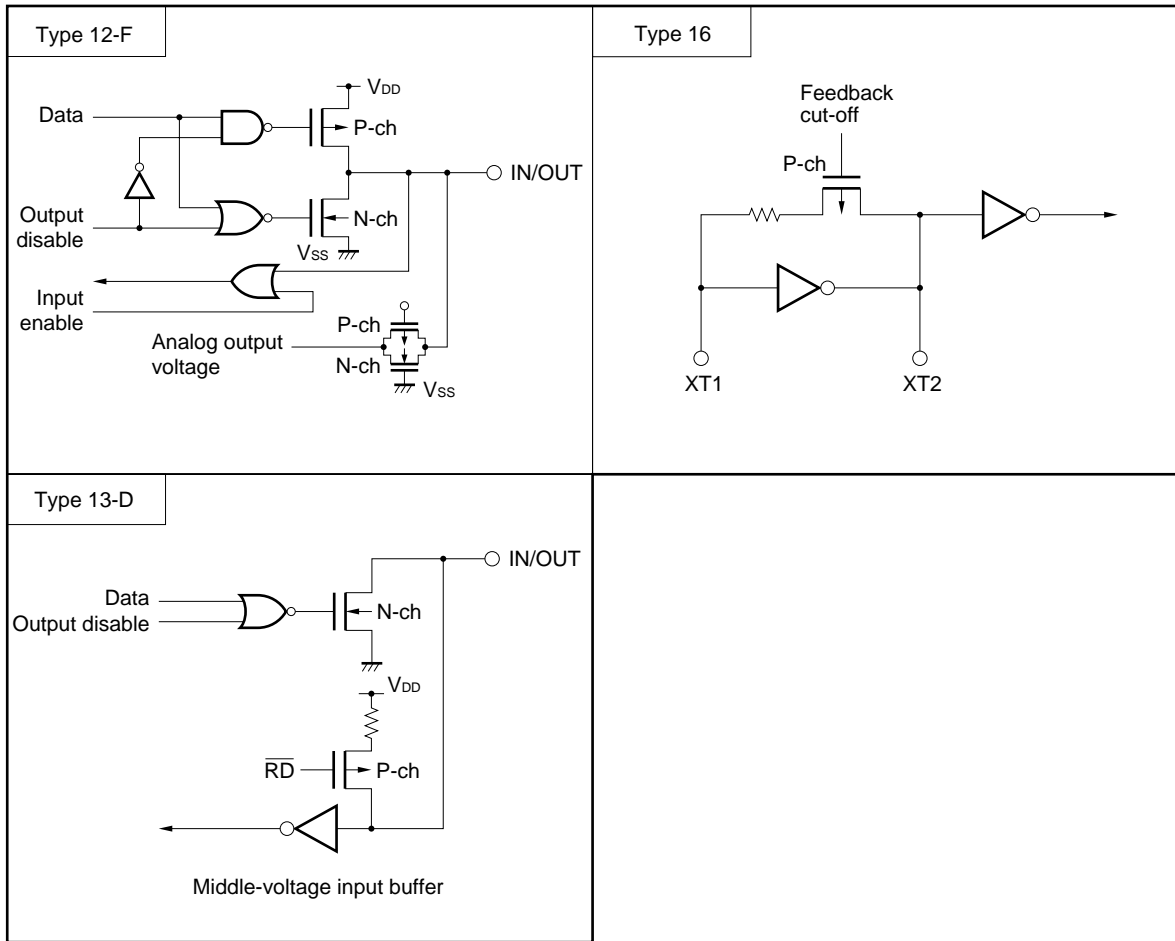

Figure 5-1. Types of Pin I/O Circuits (2/2)



★6. CPU ARCHITECTURE

6.1 Memory Space

A memory space of 1 MB can be accessed. Mapping of the internal data area (special function registers and internal RAM) can be specified by the LOCATION instruction. The LOCATION instruction must always be executed after reset cancellation, and must not be used more than once.

(1) When LOCATION 0H instruction is executed

● Internal memory

The internal data area and internal ROM area are mapped as follows.

Part Number	Internal Data Area	Internal ROM Area
μPD784214A, μPD784214AY	0F100H to 0FFFFH	00000H to 0F0FFH 10000H to 17FFFH
μPD784215A, μPD784215AY	0EB00H to 0FFFFH	00000H to 0EAFFH 10000H to 1FFFFH
μPD784216A, μPD784216AY	0DF00H to 0FFFFH	00000H to 0DEFFH 10000H to 1FFFFH
μPD784217A, μPD784217AY	0CD00H to 0FFFFH	00000H to 0CCFFH 10000H to 2FFFFH
μPD784218A, μPD784218AY		00000H to 0CCFFH 10000H to 3FFFFH

Caution The following areas that overlap the internal data area of the internal ROM cannot be used when the LOCATION 0H instruction is executed.

Part Number	Unusable Area
μPD784214A, μPD784214AY	0F100H to 0FFFFH (3,840 bytes)
μPD784215A, μPD784215AY	0EB00H to 0FFFFH (5,376 bytes)
μPD784216A, μPD784216AY	0DF00H to 0FFFFH (8,448 bytes)
μPD784217A, μPD784217AY	0CD00H to 0FFFFH (13,056 bytes)
μPD784218A, μPD784218AY	

● External memory

The external memory is accessed in external memory expansion mode.

(2) When LOCATION 0FH instruction is executed

- **Internal memory**

The internal data area and internal ROM area are mapped as follows.

Part Number	Internal Data Area	Internal ROM Area
μPD784214A, μPD784214AY	FF100H to FFFFFH	00000H to 17FFFFH
μPD784215A, μPD784215AY	FEB00H to FFFFFH	00000H to 1FFFFH
μPD784216A, μPD784216AY	FDF00H to FFFFFH	00000H to 1FFFFH
μPD784217A, μPD784217AY	FCD00H to FFFFFH	00000H to 2FFFFH
μPD784218A, μPD784218AY		00000H to 3FFFFH

- **External memory**

The external memory is accessed in external memory expansion mode.

* Figure 6-1. Memory Map of μ PD784214A, 784214AY

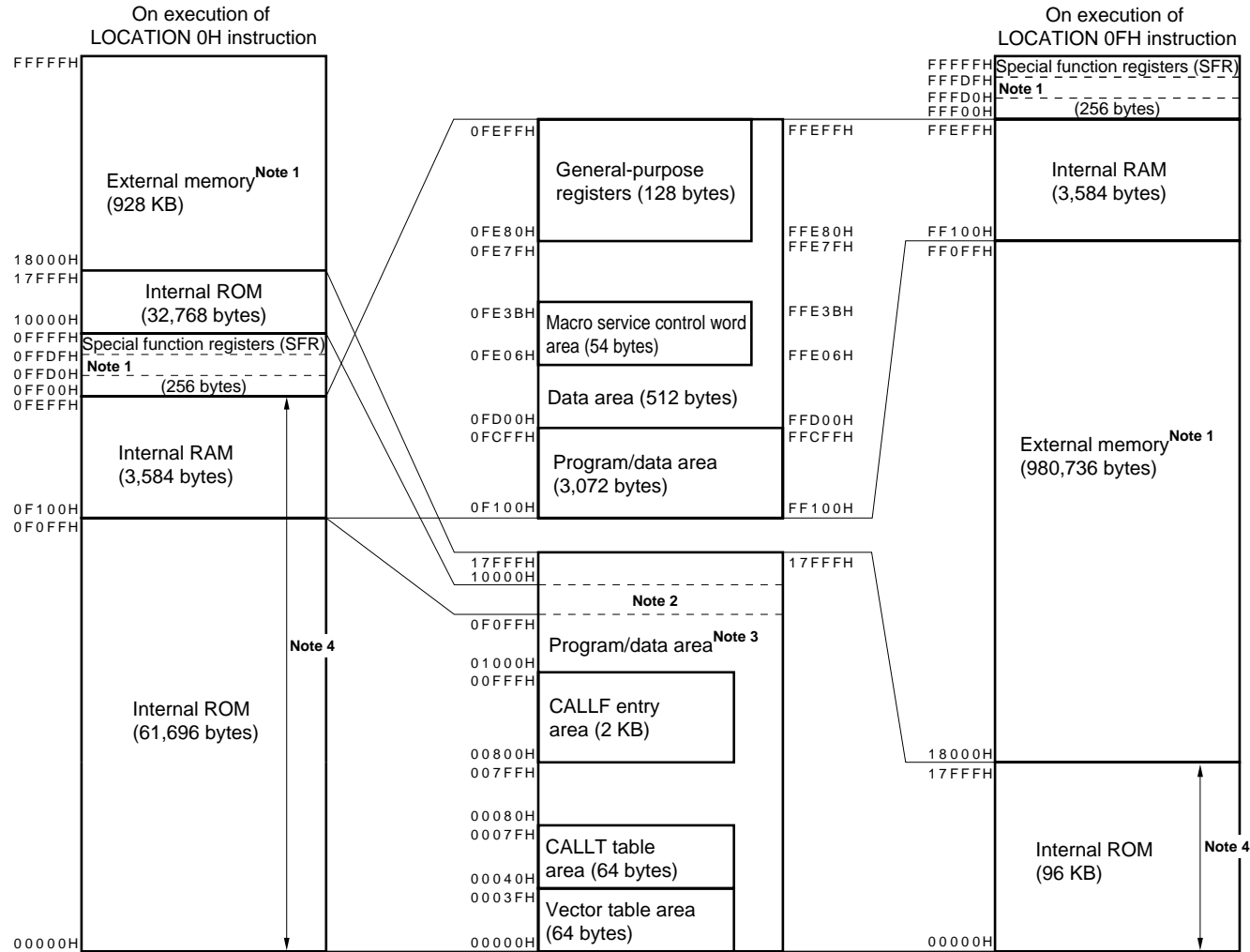

- Notes**
1. Accessed in external memory expansion mode.
 2. This 3,840-byte area can be used as an internal ROM only when the LOCATION 0FH instruction is executed.
 3. On execution of LOCATION 0H instruction: 94,464 bytes, on execution of LOCATION 0FH instruction: 98,304 bytes
 4. Base area and entry area for reset or interrupt. However, the internal RAM area is not used as a reset entry area.

* Figure 6-2. Memory Map of μPD784215A, 784215AY

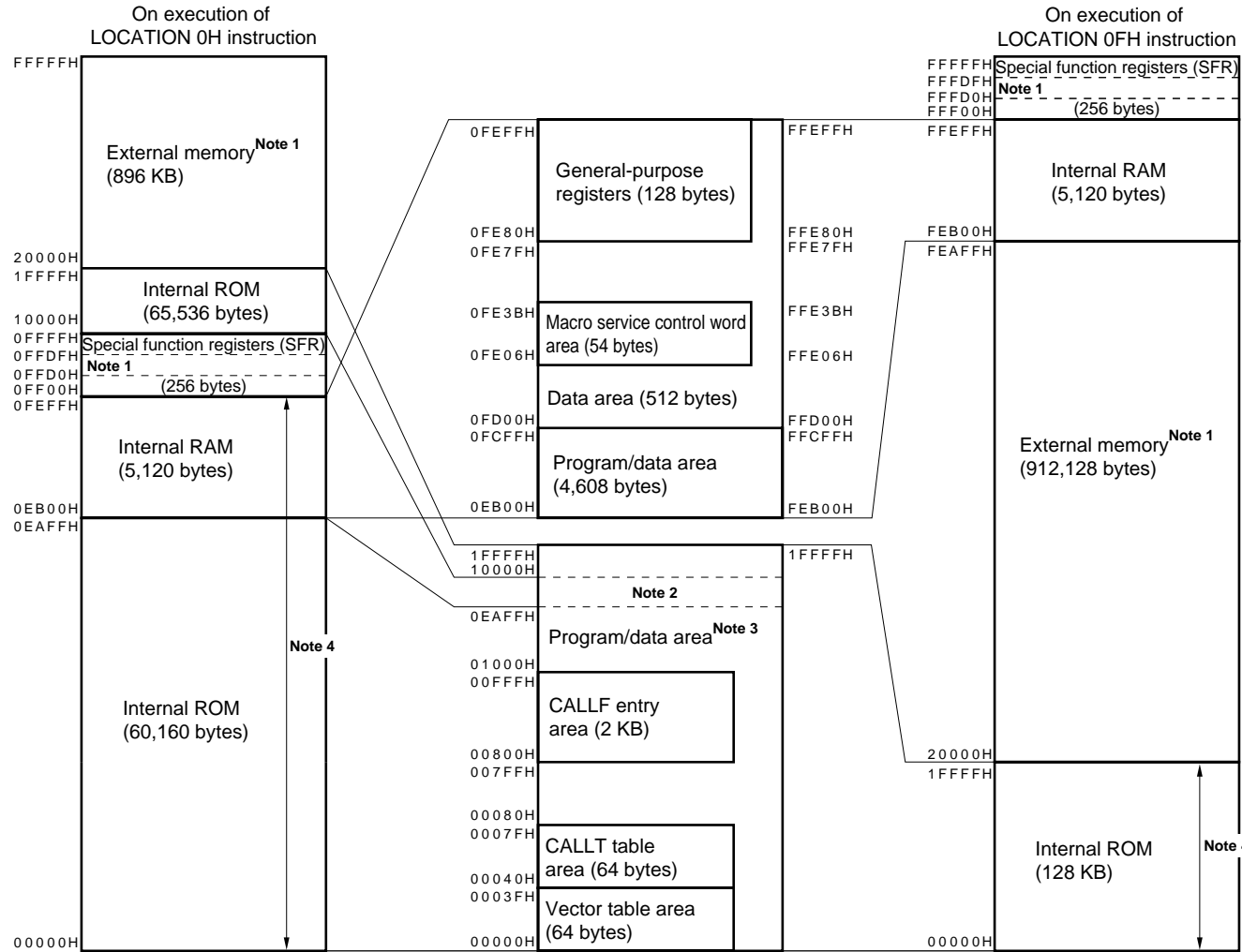

* Figure 6-3. Memory Map of μ PD784216A, 784216AY

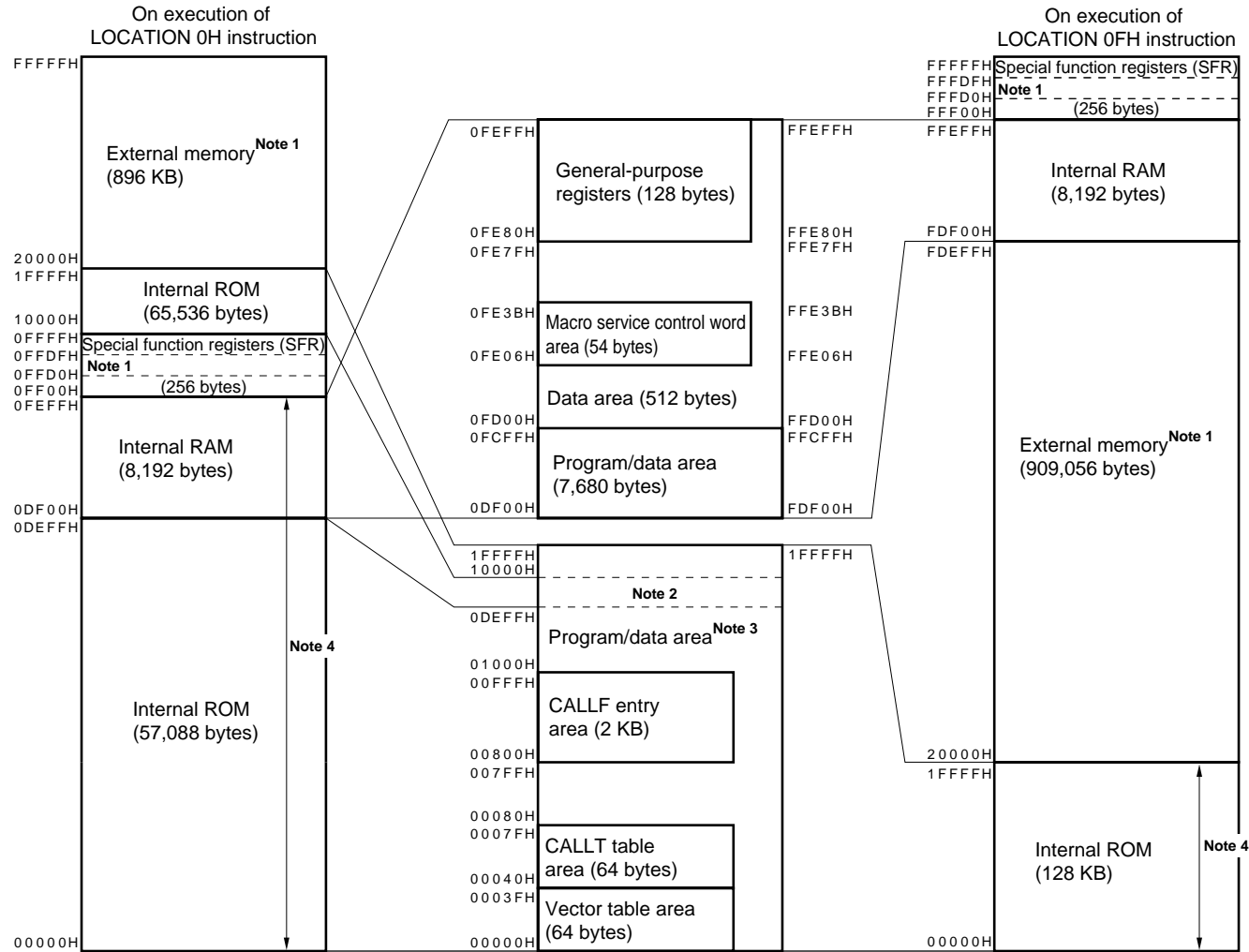

- Notes**
1. Accessed in external memory expansion mode.
 2. This 8,448-byte area can be used as an internal ROM only when the LOCATION 0FH instruction is executed.
 3. On execution of LOCATION 0H instruction: 122,624 bytes, on execution of LOCATION 0FH instruction: 131,072 bytes
 4. Base area and entry area for reset or interrupt. However, the internal RAM area is not used as a reset entry area.

Figure 6- 4. Memory Map of μPD784217A, 784217AY

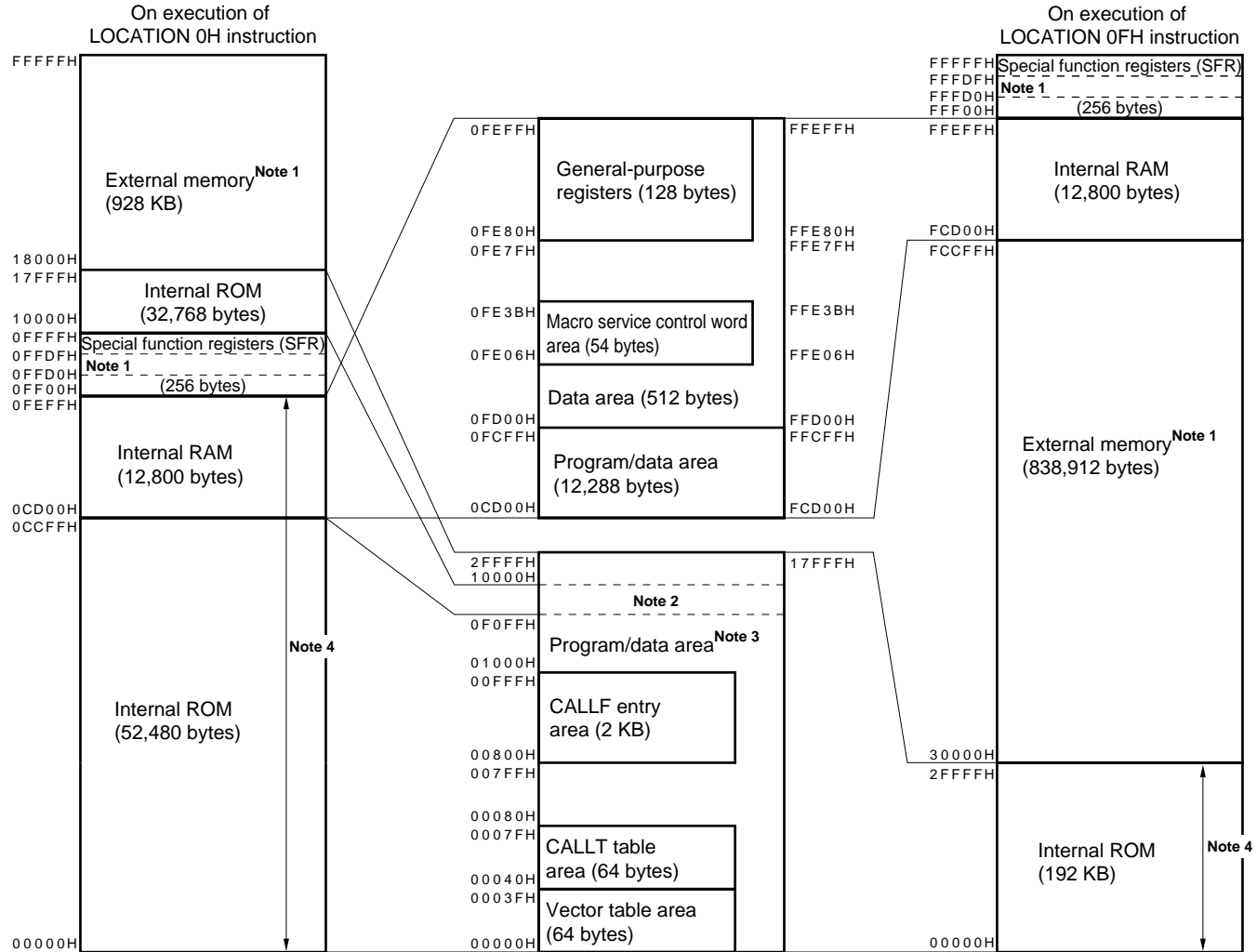

- Notes**
1. Accessed in external memory expansion mode.
 2. This 13,056-byte area can be used as internal ROM only when the LOCATION 0FH instruction is executed.
 3. On execution of LOCATION 0H instruction: 183,552 bytes, on execution of LOCATION 0FH instruction: 196,608 bytes
 4. Base area and entry area for reset or interrupt. However, the internal RAM area is not used as a reset entry area.

Figure 6-5. Memory Map of μ PD784218A, 784218AY

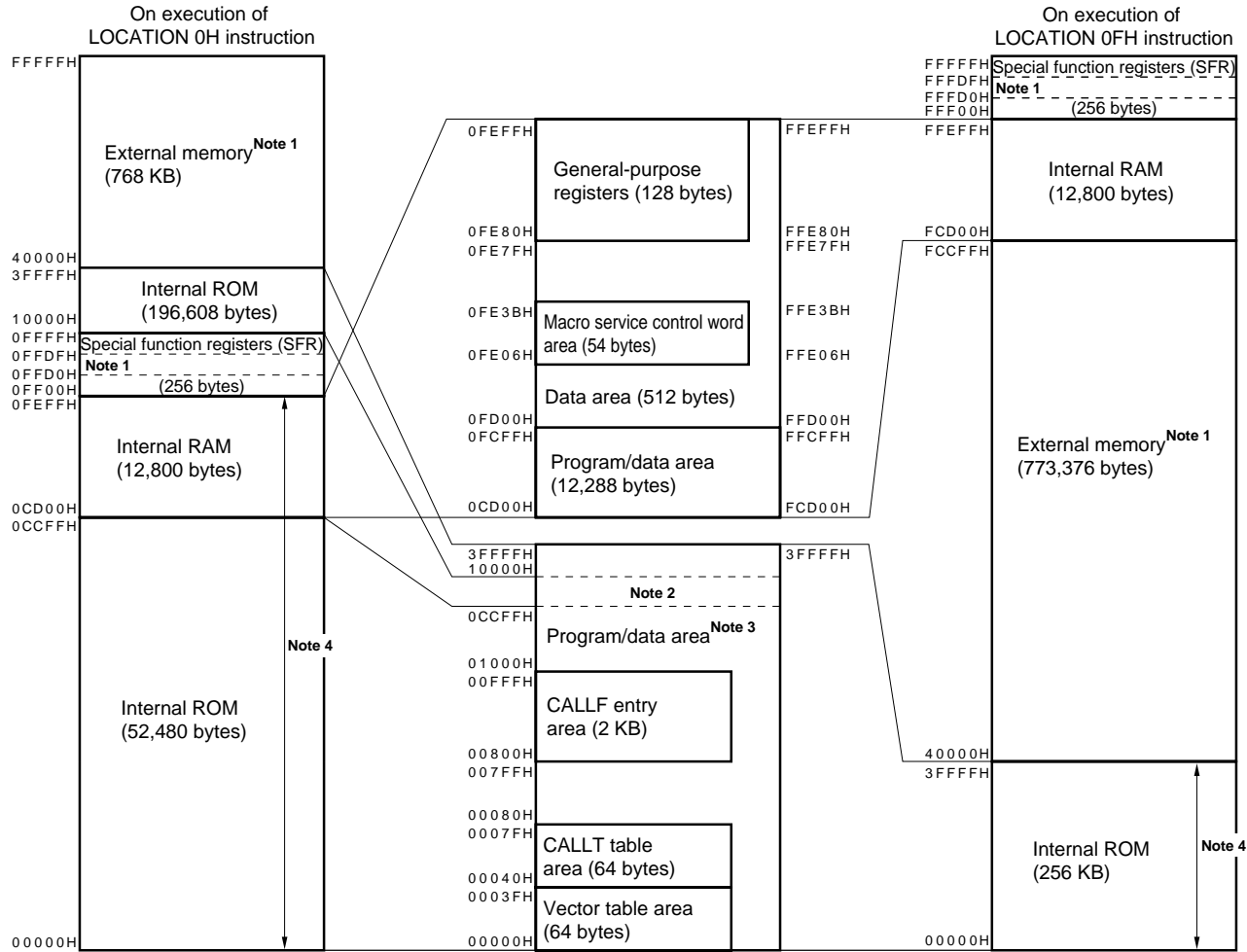

6.2 CPU Registers

6.2.1 General-purpose registers

Sixteen 8-bit general-purpose registers are available. Two 8-bit registers can also be used in pairs as a 16-bit register. Of the 16-bit registers, four can be used in combination with an 8-bit register for address expansion as 24-bit address specification registers.

Eight banks of these register sets are available and can be selected by using software or the context switching function.

The general-purpose registers except the V, U, T, and W registers for address expansion are mapped to the internal RAM.

Figure 6-6. General-Purpose Register Format

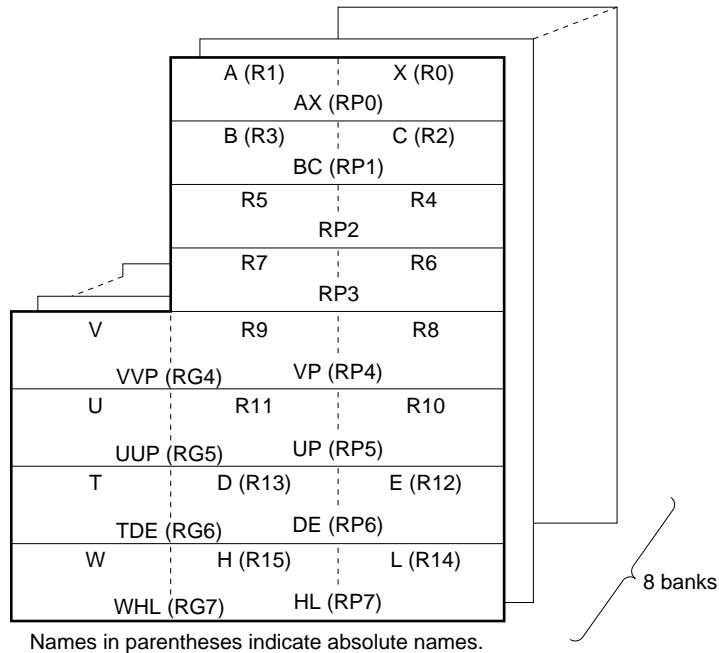

Caution Registers R4, R5, R6, R7, RP2, and RP3 can be used as the X, A, C, B, AX, and BC registers, respectively, by setting the RSS bit of the PSW to 1. However, use this function only for recycling the program of the 78K/III Series.

6.2.2 Control registers

(1) Program counter (PC)

The program counter is a 20-bit register whose contents are automatically updated when the program is executed.

Figure 6-7. Format of Program Counter (PC)

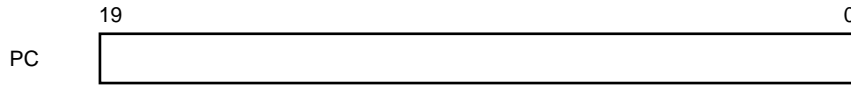

(2) Program status word (PSW)

This register holds the statuses of the CPU. Its contents are automatically updated when the program is executed.

Figure 6-8. Format of Program Status Word (PSW)

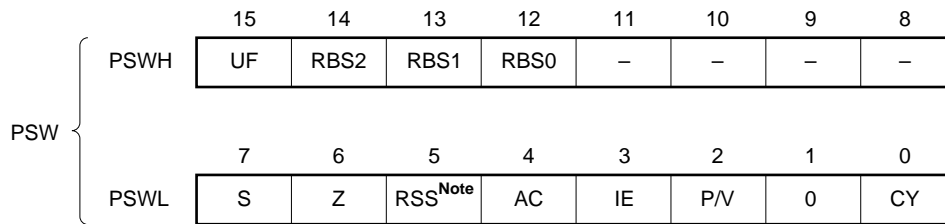

Note This flag is provided to maintain compatibility with the 78K/III Series. Be sure to clear this flag to 0, except when the software for the 78K/III Series is used.

(3) Stack pointer (SP)

This is a 24-bit pointer that holds the first address of the stack. Be sure to write 0 to the higher 4 bits of this pointer.

Figure 6-9. Format of Stack Pointer (SP)

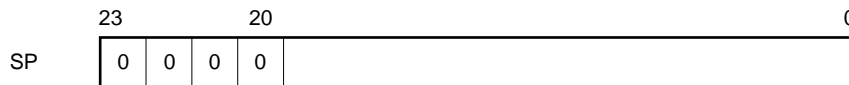

6.2.3 Special function registers (SFRs)

The special function registers, such as the mode registers and control registers of the internal peripheral hardware, are registers to which special functions are assigned. These registers are mapped to the 256-byte space of addresses 0FF00H to 0FFFFH^{Note}.

Note On execution of the LOCATION 0H instruction. FFF00H to FFFFFH on execution of the LOCATION 0FH instruction.

Caution Do not access an address in this area to which no SFR is assigned. If such an address is accessed by mistake, the μPD784218A may enter a deadlocked state. This deadlock state can be cleared only by inputting the $\overline{\text{RESET}}$ signal.

Table 6-1 lists the special function registers (SFRs). The meanings of the symbols in this table are as follows.

- SymbolSymbol indicating an SFR. This symbol is reserved for NEC's assembler (RA78K4). It can be used as an sfr variable by means of the #pragma sfr command in the C compiler (CC78K4).
- R/WIndicates whether the SFR is read-only, write-only, or read/write.
 - R/W: Read/write
 - R: Read-only
 - W: Write-only
- Bit units for manipulationBit units in which the value of the SFR can be manipulated. SFRs that can be manipulated in 16-bit units can be described as the operand sfrp of an instruction. To specify the address of this SFR, describe an even address. SFRs that can be manipulated in 1-bit units can be described as the operand of a bit manipulation instruction.
- After reset.....Indicates the status of the register when the $\overline{\text{RESET}}$ signal has been input.

Table 6-1. Special Function Register (SFR) List (1/4)

Address ^{Note 1}	Special Function Register (SFR) Name	Symbol	R/W	Bit Units for Manipulation			After Reset
				1 Bit	8 Bits	16 Bits	
0FF00H	Port 0	P0	R/W	√	√	–	00H ^{Note 2}
0FF01H	Port 1	P1	R	√	√	–	
0FF02H	Port 2	P2	R/W	√	√	–	
0FF03H	Port 3	P3		√	√	–	
0FF04H	Port 4	P4	√	√	–		
0FF05H	Port 5	P5	√	√	–		
0FF06H	Port 6	P6	√	√	–		
0FF07H	Port 7	P7	√	√	–		
0FF08H	Port 8	P8	√	√	–		
0FF09H	Port 9	P9	√	√	–		
0FF0AH	Port 10	P10	√	√	–		
0FF0CH	Port 12	P12	√	√	–		
0FF0DH	Port 13	P13	√	√	–		
0FF10H	16-bit timer counter	TM0	R	–	–	√	
0FF11H							
0FF12H	Capture/compare register 00 (16-bit timer/event counter)	CR00	R/W	–	–	√	
0FF13H							
0FF14H	Capture/compare register 01 (16-bit timer/event counter)	CR01		–	–	√	
0FF15H							
0FF16H	Capture/compare control register 0	CRC0		√	√	–	00H
0FF18H	16-bit timer mode control register	TMC0		√	√	–	
0FF1AH	16-bit timer output control register	TOC0		√	√	–	
0FF1CH	Prescaler mode register 0	PRM0		√	√	–	
0FF20H	Port 0 mode register	PM0		√	√	–	FFH
0FF22H	Port 2 mode register	PM2		√	√	–	
0FF23H	Port 3 mode register	PM3		√	√	–	
0FF24H	Port 4 mode register	PM4		√	√	–	
0FF25H	Port 5 mode register	PM5		√	√	–	
0FF26H	Port 6 mode register	PM6		√	√	–	
0FF27H	Port 7 mode register	PM7		√	√	–	
0FF28H	Port 8 mode register	PM8		√	√	–	
0FF29H	Port 9 mode register	PM9		√	√	–	
0FF2AH	Port 10 mode register	PM10		√	√	–	
0FF2CH	Port 12 mode register	PM12		√	√	–	
0FF2DH	Port 13 mode register	PM13		√	√	–	

- Notes**
1. When the LOCATION 0H instruction is executed. Add "F0000H" to this value when the LOCATION 0FH instruction is executed.
 2. Because each port is initialized to input mode after reset, "00H" is not actually read. The output latch is initialized to "0".

Table 6-1. Special Function Register (SFR) List (2/4)

Address ^{Note}	Special Function Register (SFR) Name	Symbol		R/W	Bit Units for Manipulation			After Reset
					1 Bit	8 Bits	16 Bits	
0FF30H	Pull-up resistor option register 0	PU0		R/W	√	√	–	00H
0FF32H	Pull-up resistor option register 2	PU2			√	√	–	
0FF33H	Pull-up resistor option register 3	PU3			√	√	–	
0FF37H	Pull-up resistor option register 7	PU7			√	√	–	
0FF38H	Pull-up resistor option register 8	PU8			√	√	–	
0FF3AH	Pull-up resistor option register 10	PU10			√	√	–	
0FF3CH	Pull-up resistor option register 12	PU12			√	√	–	
0FF40H	Clock output control register	CKS			√	√	–	
0FF42H	Port function control register	PF2			√	√	–	
0FF4EH	Pull-up resistor option register	PUO			√	√	–	
0FF50H	8-bit timer counter 1	TM1	TM1W	R	–	√	√	0000H
0FF51H	8-bit timer counter 2	TM2			–	√		
0FF52H	Compare register 10 (8-bit timer/event counter 1)	CR10	CR1W	R/W	–	√	√	
0FF53H	Compare register 20 (8-bit timer/event counter 2)	CR20			–	√		
0FF54H	8-bit timer mode control register 1	TMC1	TMC1W		√	√	√	
0FF55H	8-bit timer mode control register 2	TMC2			√	√		
0FF56H	Prescaler mode register 1	PRM1	PRM1W		√	√	√	
0FF57H	Prescaler mode register 2	PRM2			√	√		
0FF60H	8-bit timer counter 5	TM5	TM5W	R	–	√	√	
0FF61H	8-bit timer counter 6	TM6			–	√		
0FF62H	8-bit timer counter 7	TM7	TM7W		–	√	√	
0FF63H	8-bit timer counter 8	TM8			–	√		
0FF64H	Compare register 50 (8-bit timer/event counter 5)	CR50	CR5W	R/W	–	√	√	
0FF65H	Compare register 60 (8-bit timer/event counter 6)	CR60			–	√		
0FF66H	Compare register 70 (8-bit timer/event counter 7)	CR70	CR7W		–	√	√	
0FF67H	Compare register 80 (8-bit timer/event counter 8)	CR80			–	√		
0FF68H	8-bit timer mode control register 5	TMC5	TMC5W		√	√	√	
0FF69H	8-bit timer mode control register 6	TMC6			√	√		
0FF6AH	8-bit timer mode control register 7	TMC7	TMC7W		√	√	√	
0FF6BH	8-bit timer mode control register 8	TMC8			√	√		
0FF6CH	Prescaler mode register 5	PRM5	PRM5W		√	√	√	
0FF6DH	Prescaler mode register 6	PRM6			√	√		
0FF6EH	Prescaler mode register 7	PRM7	PRM7W		√	√	√	
0FF6FH	Prescaler mode register 8	PRM8			√	√		
0FF70H	Asynchronous serial interface mode register 1	ASIM1		R	√	√	–	00H
0FF71H	Asynchronous serial interface mode register 2	ASIM2			√	√	–	
0FF72H	Asynchronous serial interface status register 1	ASIS1			√	√	–	
0FF73H	Asynchronous serial interface status register 2	ASIS2			√	√	–	

Note When the LOCATION 0H instruction is executed. Add "F000H" to this value when the LOCATION 0FH instruction is executed.

Table 6-1. Special Function Register (SFR) List (3/4)

Address ^{Note 1}	Special Function Register (SFR) Name	Symbol	R/W	Bit Units for Manipulation			After Reset		
				1 Bit	8 Bits	16 Bits			
0FF74H	Transmit shift register 1	TXS1	W	–	√	–	FFH		
	Receive buffer register 1	RXB1	R	–	√	–			
0FF75H	Transmit shift register 2	TXS2	W	–	√	–			
	Receive buffer register 2	RXB2	R	–	√	–			
0FF76H	Baud rate generator control register 1	BRGC1	R/W	√	√	–	00H		
0FF77H	Baud rate generator control register 2	BRGC2		√	√	–			
0FF7AH	Oscillation mode select register	CC		√	√	–			
0FF80H	A/D converter mode register	ADM		√	√	–			
0FF81H	A/D converter input select register	ADIS		√	√	–			
0FF83H	A/D conversion result register	ADCR	R	–	√	–	Undefined		
0FF84H	D/A conversion value setting register 0	DACS0	R/W	√	√	–	00H		
0FF85H	D/A conversion value setting register 1	DACS1		√	√	–			
0FF86H	D/A converter mode register 0	DAM0		√	√	–			
0FF87H	D/A converter mode register 1	DAM1		√	√	–			
0FF8CH	External bus type select register	EBTS		√	√	–			
0FF90H	Serial operation mode register 0	CSIM0		√	√	–			
0FF91H	Serial operation mode register 1	CSIM1		√	√	–			
0FF92H	Serial operation mode register 2	CSIM2		√	√	–			
0FF94H	Serial I/O shift register 0	SIO0		–	√	–			
0FF95H	Serial I/O shift register 1	SIO1		–	√	–			
0FF96H	Serial I/O shift register 2	SIO2		–	√	–			
0FF98H	Real-time output buffer register L	RTBL		–	√	–			
0FF99H	Real-time output buffer register H	RTBH		–	√	–			
0FF9AH	Real-time output port mode register	RTPM		√	√	–			
0FF9BH	Real-time output port control register	RTPC		√	√	–			
0FF9CH	Watch timer mode control register	WTM		√	√	–			
0FFA0H	External interrupt rising edge enable register	EGP0		√	√	–			
0FFA2H	External interrupt falling edge enable register	EGN0		√	√	–			
0FFA8H	In-service priority register	ISPR		R	√	√		–	
0FFA9H	Interrupt select control register	SNMI		R/W	√	√		–	80H
0FFAAH	Interrupt mode control register	IMC			√	√		–	
0FFACH	Interrupt mask flag register 0L	MK0L		MK0	√	√		√	FFFFH
0FFADH	Interrupt mask flag register 0H	MK0H			√	√			
0FFAEH	Interrupt mask flag register 1L	MK1L	MK1	√	√	√			
0FFAFH	Interrupt mask flag register 1H	MK1H		√	√				
0FFB0H	I ² C bus control register ^{Note 2}	IICC0		√	√	–	00H		
0FFB2H	Prescaler mode register for serial clock	SPRM0		√	√	–			
0FFB4H	Slave address register	SVA0		√	√	–			

- Notes**
1. When the LOCATION 0H instruction is executed. Add "F000H" to this value when the LOCATION 0FH instruction is executed.
 2. μPD784216AY/784218AY Subseries only

Table 6-1. Special Function Register (SFR) List (4/4)

Address ^{Note 1}	Special Function Register (SFR) Name	Symbol	R/W	Bit Units for Manipulation			After Reset
				1 Bit	8 Bits	16 Bits	
0FFB6H	I ² C bus status register ^{Note 2}	IICS0	R	√	√	–	00H
0FFB8H	Serial shift register	IIC0	R/W	√	√	–	
0FFC0H	Standby control register	STBC		–	√	–	30H
0FFC2H	Watchdog timer mode register	WDM		–	√	–	00H
0FFC4H	Memory expansion mode register	MM		√	√	–	20H
0FFC7H	Programmable wait control register 1	PWC1		√	√	–	AAH
0FFCEH	Clock status register	PCS	R	√	√	–	32H
0FFCFH	Oscillation stabilization time specification register	OSTS	R/W	√	√	–	00H
0FFD0H to 0FFDFH	External SFR area	–		√	√	–	–
0FFE0H	Interrupt control register (INTWDTM)	WDTIC		√	√	–	43H
0FFE1H	Interrupt control register (INTP0)	PIC0		√	√	–	
0FFE2H	Interrupt control register (INTP1)	PIC1		√	√	–	
0FFE3H	Interrupt control register (INTP2)	PIC2		√	√	–	
0FFE4H	Interrupt control register (INTP3)	PIC3		√	√	–	
0FFE5H	Interrupt control register (INTP4)	PIC4		√	√	–	
0FFE6H	Interrupt control register (INTP5)	PIC5		√	√	–	
0FFE7H	Interrupt control register (INTP6)	PIC6		√	√	–	
0FFE8H	Interrupt control register (INTIIC0/INTCSI0)	CSIIC0		√	√	–	
0FFE9H	Interrupt control register (INTSER1)	SERIC1		√	√	–	
0FFEAH	Interrupt control register (INTSR1/INTCSI1)	SRIC1		√	√	–	
0FFEBH	Interrupt control register (INTST1)	STIC1		√	√	–	
0FFECH	Interrupt control register (INTSER2)	SERIC2		√	√	–	
0FFEDH	Interrupt control register (INTSR2/INTCSI2)	SRIC2		√	√	–	
0FFEEH	Interrupt control register (INTST2)	STIC2		√	√	–	
0FFEFH	Interrupt control register (INTTM3)	TMIC3		√	√	–	
0FFF0H	Interrupt control register (INTTM00)	TMIC00		√	√	–	
0FFF1H	Interrupt control register (INTTM01)	TMIC01		√	√	–	
0FFF2H	Interrupt control register (INTTM1)	TMIC1		√	√	–	
0FFF3H	Interrupt control register (INTTM2)	TMIC2		√	√	–	
0FFF4H	Interrupt control register (INTAD)	ADIC		√	√	–	
0FFF5H	Interrupt control register (INTTM5)	TMIC5		√	√	–	
0FFF6H	Interrupt control register (INTTM6)	TMIC6		√	√	–	
0FFF7H	Interrupt control register (INTTM7)	TMIC7		√	√	–	
0FFF8H	Interrupt control register (INTTM8)	TMIC8		√	√	–	
0FFF9H	Interrupt control register (INTWT)	WTIC		√	√	–	
0FFFAH	Interrupt control register (INTKR)	KRIC		√	√	–	

Notes 1. When the LOCATION 0H instruction is executed. Add "F0000H" to this value when the LOCATION 0FH instruction is executed.

2. μPD784216AY/784218AY Subseries only

7. PERIPHERAL HARDWARE FUNCTIONS

7.1 Ports

The ports shown in Figure 7-1 are provided to make various control operations possible. Table 7-1 shows the function of each port. Ports 0, 2 through 8, 10, and 12 can be connected to on-chip pull-up resistors by means of software when in input mode.

Figure 7-1. Port Configuration

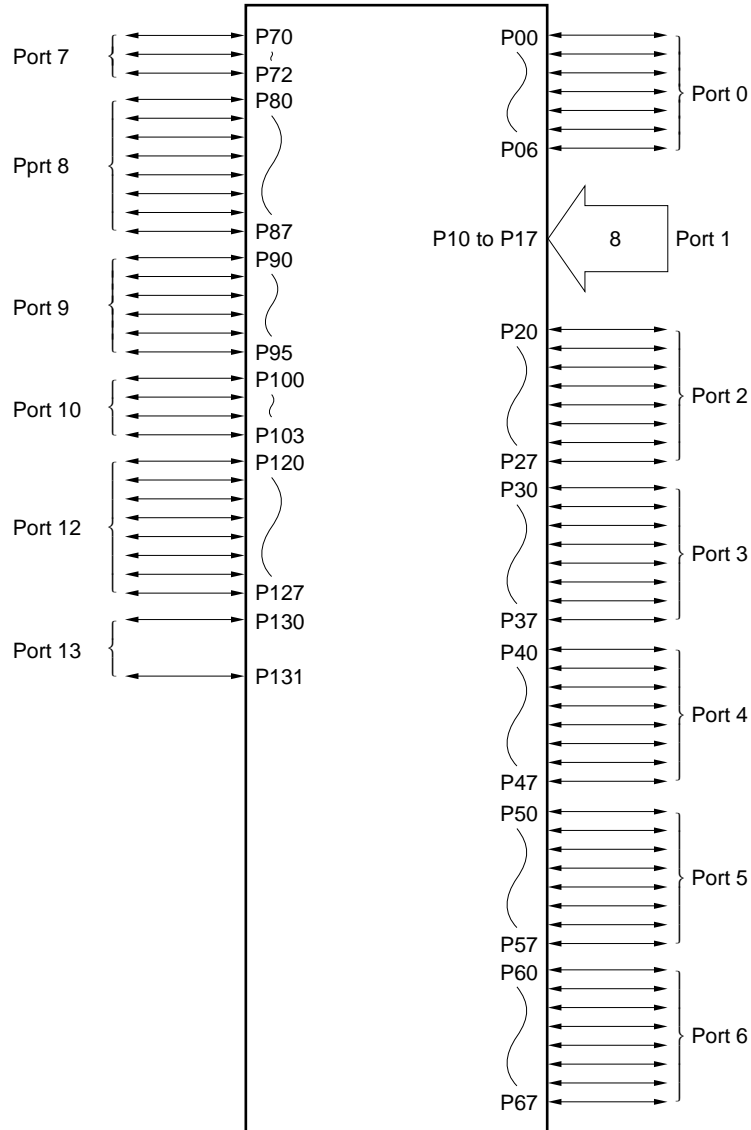

Table 7-1. Port Functions

Port Name	Pin Name	Function	Specification of Pull-up Resistor Connection by Software
Port 0	P00 to P06	• Input/output can be specified in 1-bit units	Can be specified in 1-bit units
Port 1	P10 to P17	• Input port	–
Port 2	P20 to P27	• Input/output can be specified in 1-bit units	Can be specified in 1-bit units
Port 3	P30 to P37	• Input/output can be specified in 1-bit units	Can be specified in 1-bit units
Port 4	P40 to P47	• Input/output can be specified in 1-bit units • LEDs can be driven directly	Can be specified in 1-port units
Port 5	P50 to P57	• Input/output can be specified in 1-bit units • LEDs can be driven directly	Can be specified in 1-port units
Port 6	P60 to P67	• Input/output can be specified in 1-bit units	Can be specified in 1-port units
Port 7	P70 to P72	• Input/output can be specified in 1-bit units	Can be specified in 1-bit units
Port 8	P80 to P87	• Input/output can be specified in 1-bit units	Can be specified in 1-bit units
Port 9	P90 to P95	• N-ch open-drain I/O port • Input/output can be specified in 1-bit units • LEDs can be driven directly	–
Port 10	P100 to P103	• Input/output can be specified in 1-bit units	Can be specified in 1-bit units
Port 12	P120 to P127	• Input/output can be specified in 1-bit units	Can be specified in 1-bit units
Port 13	P130, P131	• Input/output can be specified in 1-bit units	–

7.2 Clock Generator

An on-chip clock generator necessary for operation is provided. This clock generator has a frequency divider. If high-speed operation is not necessary, the internal operating frequency can be lowered by the frequency divider to reduce the current consumption.

Figure 7-2. Block Diagram of Clock Generator

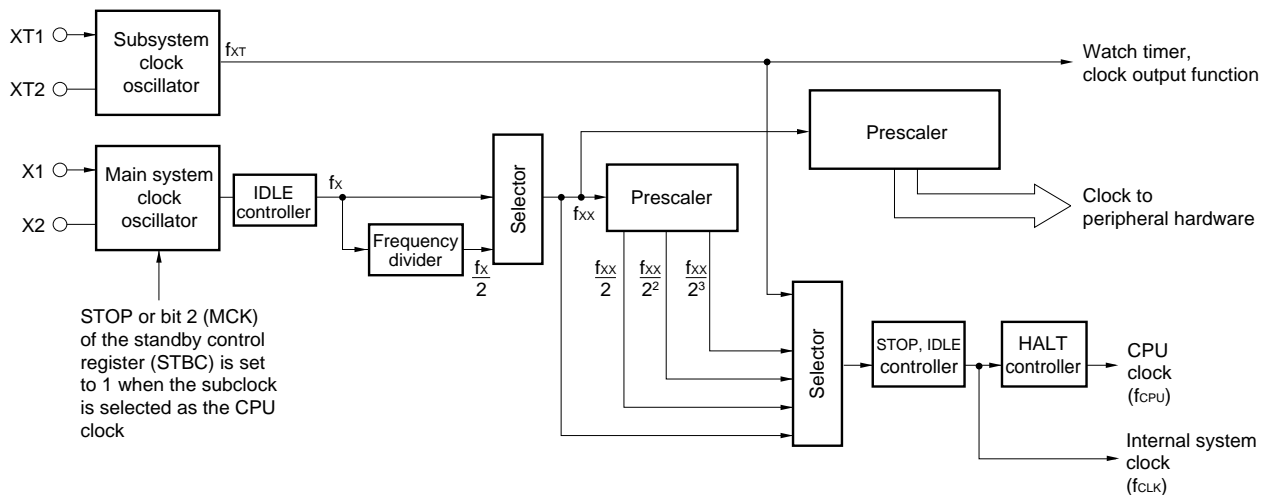

Figure 7-3. Example of Using Main System Clock Oscillator

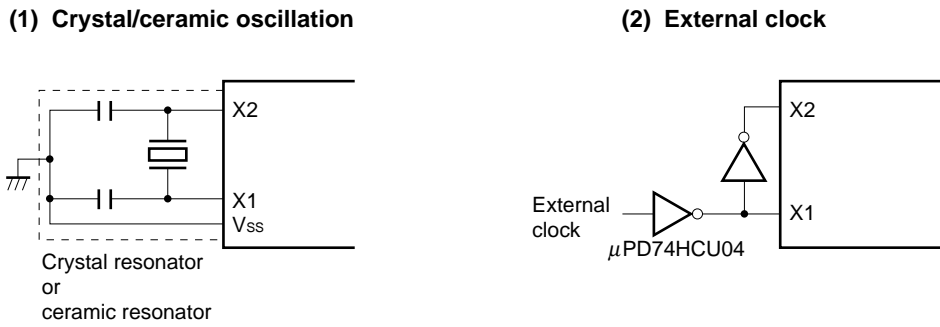
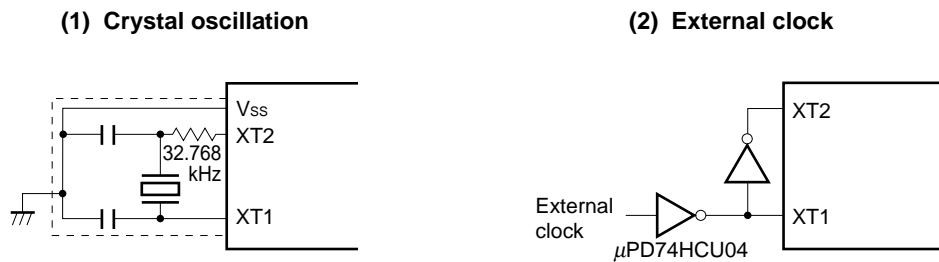

Figure 7-4. Example of Using Subsystem Clock Oscillator



Caution When using the main system clock and subsystem clock oscillator, wire as follows in the area enclosed by the broken lines in Figures 7-3 and 7-4 to avoid an adverse effect from wiring capacitance.

- Keep the wiring length as short as possible.
- Do not cross the wiring with other signal lines.
- Do not route the wiring near a signal line through which a high fluctuating current flows.
- Always make the ground point of the oscillator capacitor the same potential as Vss. Do not ground the capacitor to a ground pattern through which a high current flows.
- Do not fetch signals from the oscillator.

Note that the subsystem clock oscillator has a low amplification factor to reduce the current consumption.

7.3 Real-Time Output Port

The real-time output function is to transfer data set in advance to the real-time output buffer register to the output latch as soon as the timer interrupt or external interrupt has occurred in order to output the data to an external device. The pins that output the data to the external device constitute a port called a real-time output port.

Because the real-time output port can output signals without jitter, it is ideal for controlling a stepper motor.

Figure 7-5. Block Diagram of Real-Time Output Port

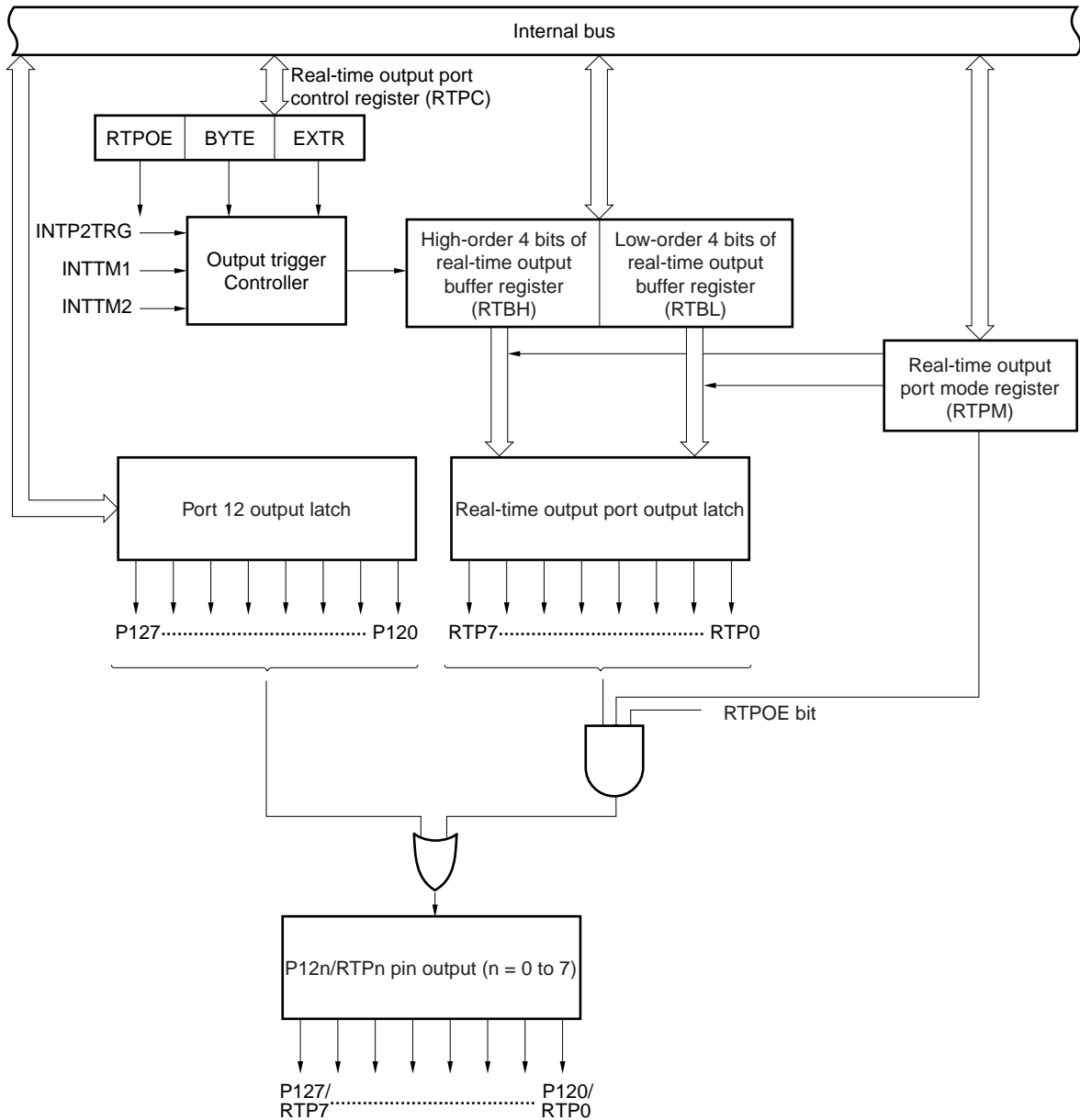

7.4 Timer/Event Counter

One unit of 16-bit timer/event counter and six 8-bit timer/event counters are provided.

Because a total of eight interrupt requests are supported, these timer/event counters can be used as eight timer/counters.

Table 7-2. Operations of Timers

Name		16-Bit	8-Bit	8-Bit	8-Bit	8-Bit	8-Bit	8-Bit
		Timer/ Event Counter	Timer/ Event Counter 1	Timer/ Event Counter 2	Timer/ Event Counter 5	Timer/ Event Counter 6	Timer/ Event Counter 7	Timer/ Event Counter 8
Item	Count width							
	8 bits	–	√	√	√	√	√	√
	16 bits	√	√		√		√	
Operation mode	Interval timer	1 ch	1 ch	1 ch	1 ch	1 ch	1 ch	1 ch
	External event counter	√	√	√	√	√	√	√
Function	Timer output	1 ch	1 ch	1 ch	1 ch	1 ch	1 ch	1 ch
	PPG output	√	–	–	–	–	–	–
	PWM output	–	√	√	√	√	√	√
	Square wave output	√	√	√	√	√	√	√
	One-shot pulse output	√	–	–	–	–	–	–
	Pulse width measurement	2 inputs	–	–	–	–	–	–
	Number of interrupt requests	2	1	1	1	1	1	1

Figure 7-6. Block Diagram of Timer/Event Counters

16-bit timer/event counter

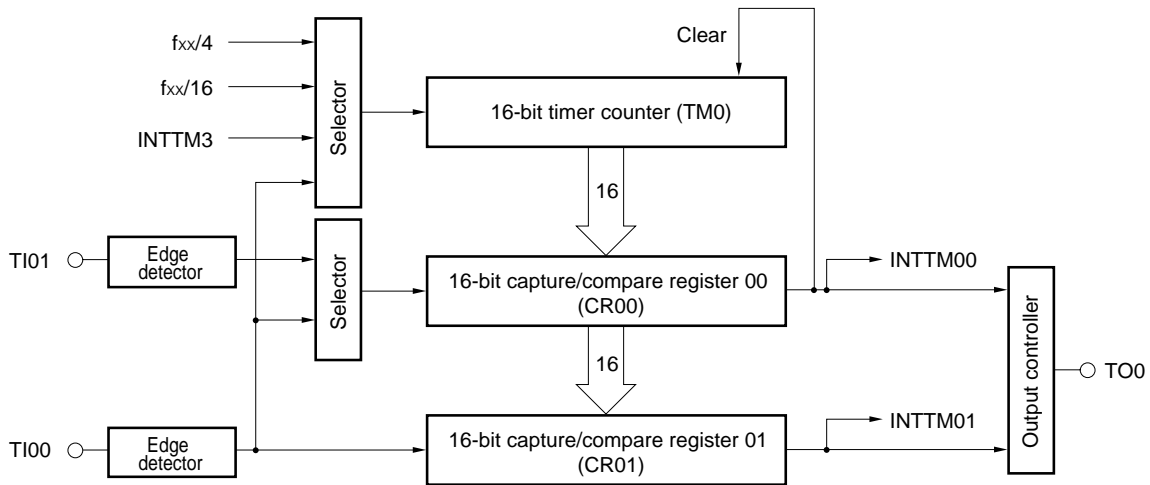

8-bit timer/event counter 1, 5, 7

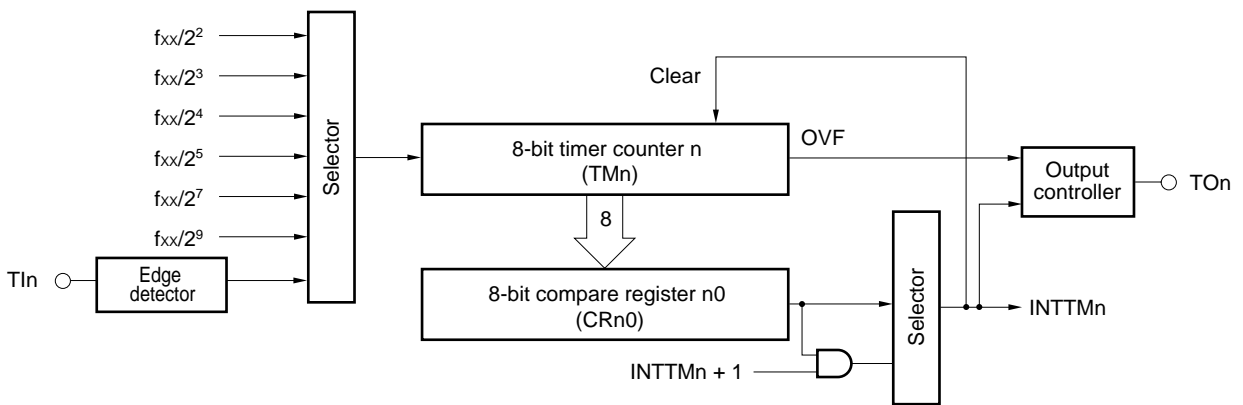

- Remarks 1. $n = 1, 5, 7$
 2. OVF: Overflow flag

8-bit timer/event counter 2, 6, 8

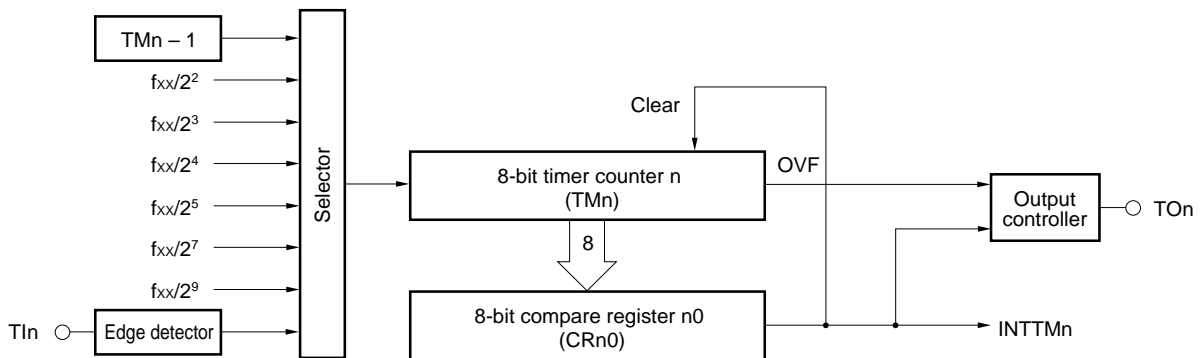

- Remarks 1. $n = 2, 6, 8$
 2. OVF: Overflow flag

7.5 A/D Converter

An A/D converter converts an analog signal input into a digital signal. This microcontroller is provided with an A/D converter with a resolution of 8 bits and eight channels (ANI0 to ANI7).

This A/D converter is of successive approximation type and the result of conversion is stored in an 8-bit A/D conversion result register (ADCR).

The A/D converter can be started in the following two ways:

- Hardware start
Conversion is started by trigger input (P03).
- Software start
Conversion is started by setting the A/D converter mode register (ADM).

One analog input channel is selected from ANI0 to ANI7 for A/D conversion. When A/D conversion is started by means of hardware start, conversion is stopped after it has been completed. When conversion is started by means of software start, A/D conversion is repeatedly executed. Each time conversion has been completed, an interrupt request (INTAD) is generated.

Figure 7-7. Block Diagram of A/D Converter

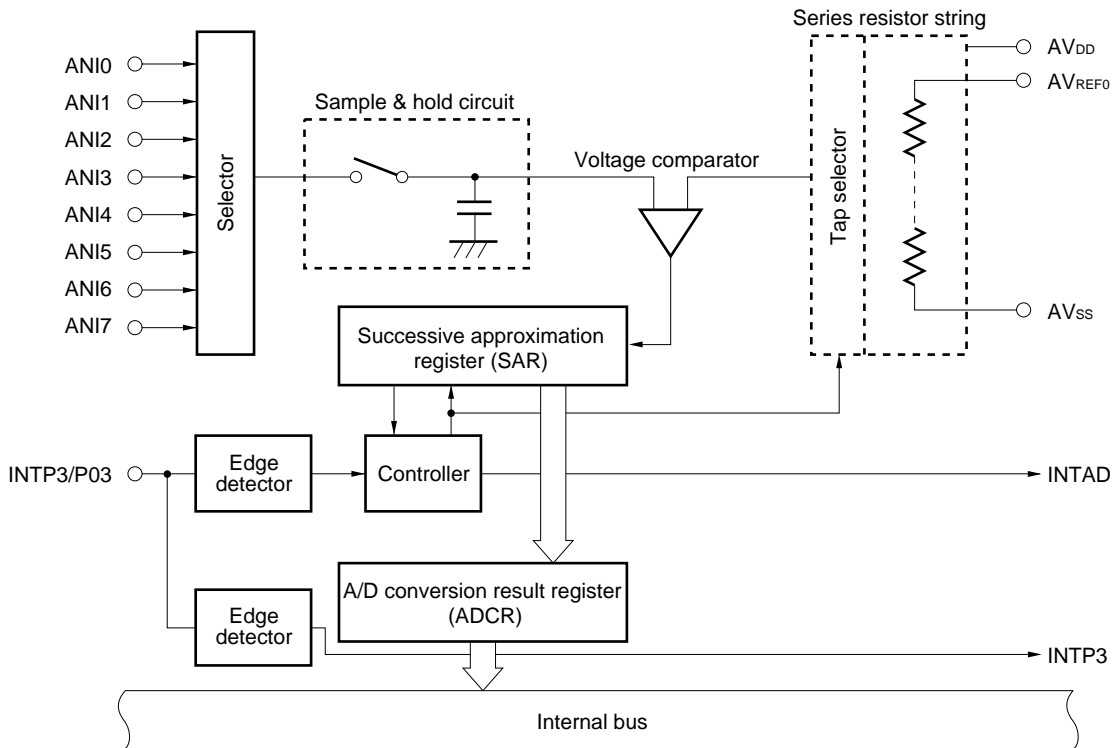

7.6 D/A Converter

A D/A converter converts a digital signal input into an analog signal. This microcontroller is provided with a voltage output type D/A converter with a resolution of 8 bits and two channels.

The conversion method is of R-2R resistor ladder type.

D/A conversion is started by setting DACE0 of D/A converter mode register 0 (DAM0) and DACE1 of D/A converter mode register 1 (DAM1).

The D/A converter operates in the following two modes:

- Normal mode
The converter outputs an analog voltage immediately after it has completed D/A conversion.
- Real-time output mode
The converter outputs an analog voltage in synchronization with an output trigger after it has completed D/A conversion.

Figure 7-8. Block Diagram of D/A Converter

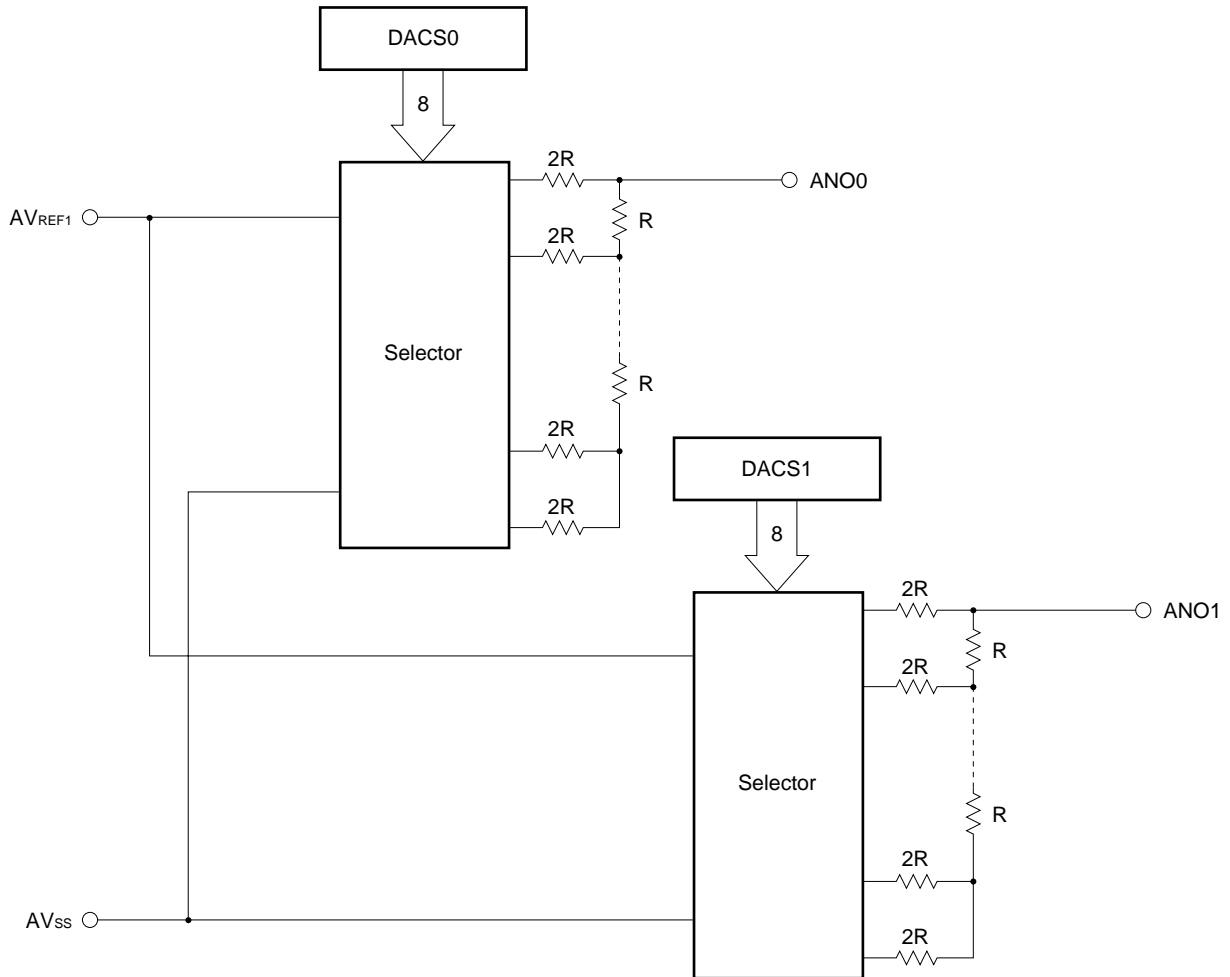

7.7 Serial Interface

Three independent serial interface channels are provided.

- Asynchronous serial interface (UART)/3-wire serial I/O (IOE) × 2
- Clocked serial interface (CSI) × 1
 - 3-wire serial I/O (IOE)
 - I²C bus interface (I²C) (μPD784216AY/784218AY Subseries only)

Therefore, communication with an external system and local communication within the system can be simultaneously executed (refer to **Figure 7-9**).

Figure 7-9. Example of Serial Interface

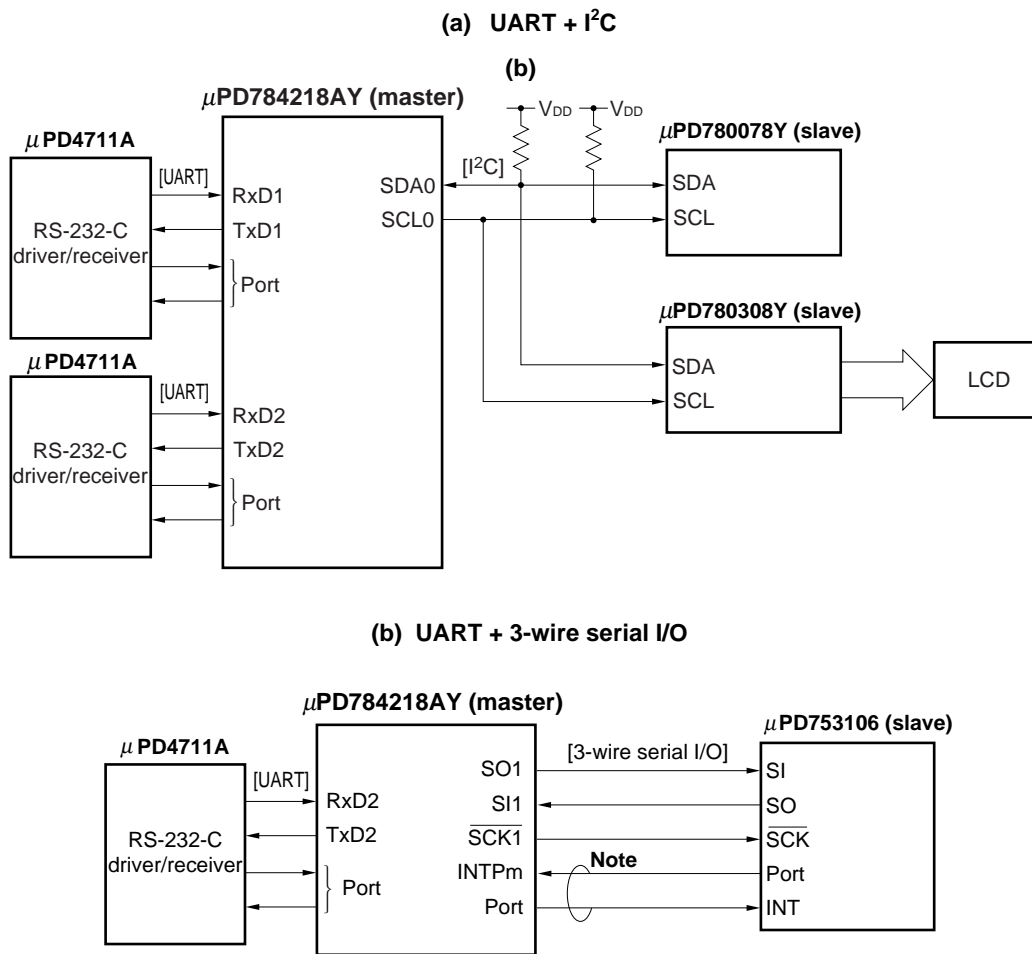

Note Handshake line

7.7.1 Asynchronous serial interface/3-wire serial I/O (UART/IOE)

Two channels of serial interfaces for which an asynchronous serial interface mode and a 3-wire serial I/O mode can be selected are provided.

(1) Asynchronous serial interface mode

In this mode, data of 1 byte following the start bit is transmitted or received.

Because an on-chip baud rate generator is provided, a wide range of baud rates can be set.

Moreover, the clock input to the ASCK pin can be divided to define a baud rate.

When the baud rate generator is used, a baud rate conforming to the MIDI standard (31.25 kbps) can also be obtained.

Figure 7-10. Block Diagram in Asynchronous Serial Interface Mode

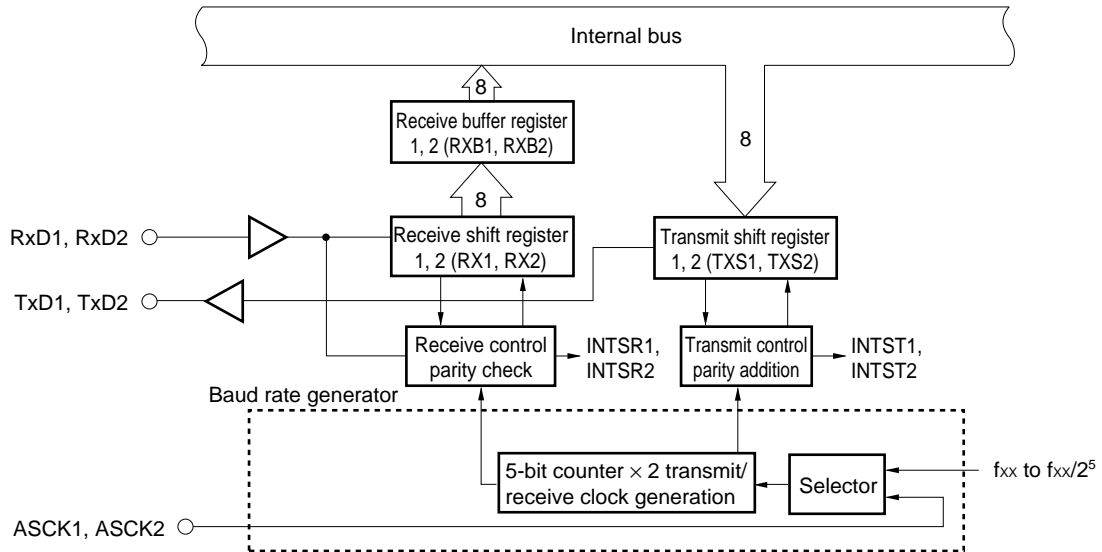

(2) 3-wire serial I/O mode

In this mode, the master device starts transfer by making the serial clock active and transfers 1-byte data in synchronization with this clock.

This mode is used to communicate with a device having a conventional clocked serial interface. Basically, communication is established by using three lines: serial clocks ($\overline{SCK1}$ and $\overline{SCK2}$), serial data inputs (SI1 and SI2), and serial data outputs (SO1 and SO2). To connect two or more devices, a handshake line is necessary.

Figure 7-11. Block Diagram in 3-Wire Serial I/O Mode

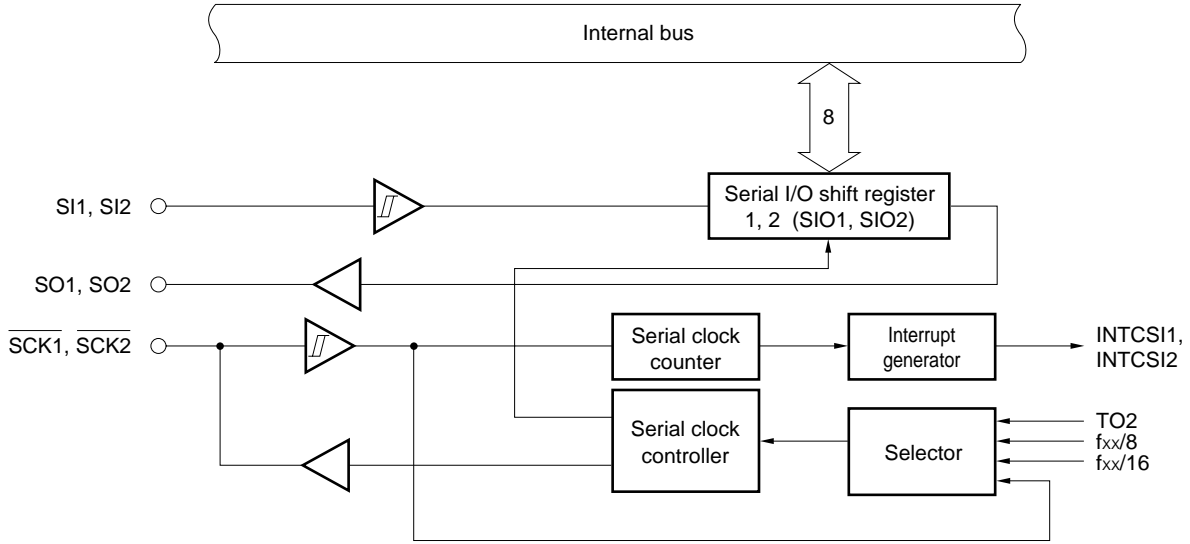

7.7.2 Clocked serial interface (CSI)

In this mode, the master device starts transfer by making the serial clock active and transfers 1-byte data in synchronization with this clock.

(1) 3-wire serial I/O mode

This mode is to communicate with devices having a conventional clocked serial interface.

Basically, communication is established in this mode with three lines: serial clock ($\overline{SCK0}$) serial data input (SI0), and serial data output (SO0) lines.

Generally, a handshake line is necessary to check the reception status.

Figure 7-12. Block Diagram in 3-Wire Serial I/O Mode

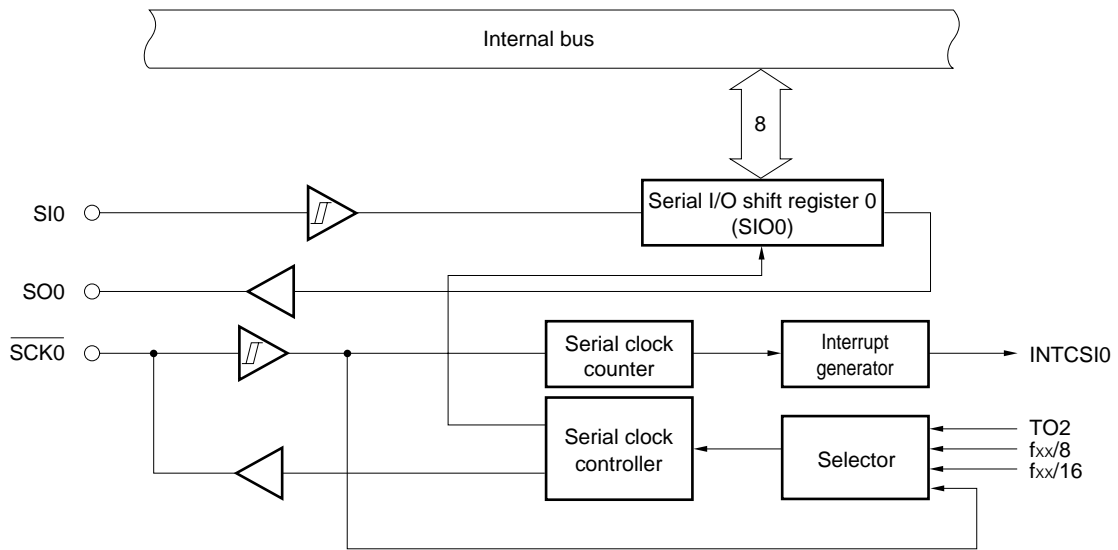

(2) I²C bus (Inter IC) bus mode (supporting multimaster) (μPD784216AY/784218AY Subseries only)

This mode is for communication with devices conforming to the I²C bus format.

This mode is for transferring 8-bit data between two or more devices by using two lines: serial clock (SCL0) and serial data bus (SDA0) lines.

During transmission, a “start condition”, “data”, and “stop condition” can be output onto the serial data bus.

During reception, these data are automatically detected by hardware.

Figure 7-13. Block Diagram of I²C Bus Mode

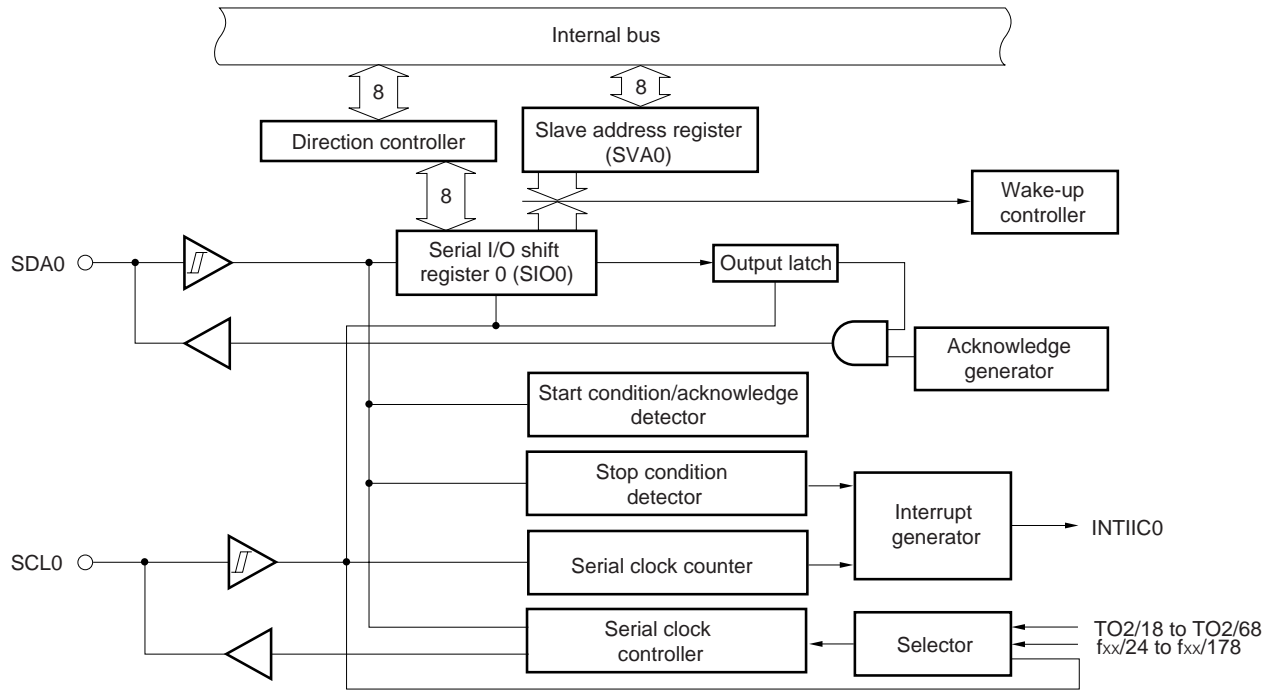

7.8 Clock Output Function

Clocks of the following frequencies can be output as clock output.

- 97.7 kHz/195 kHz/391 kHz/781 kHz/1.56 MHz/3.13 MHz/6.25 MHz/12.5 MHz
(@12.5 MHz operation with main system clock)
- 32.768 kHz (@32.768 kHz operation with subsystem clock)

Figure 7-14. Block Diagram of Clock Output Function

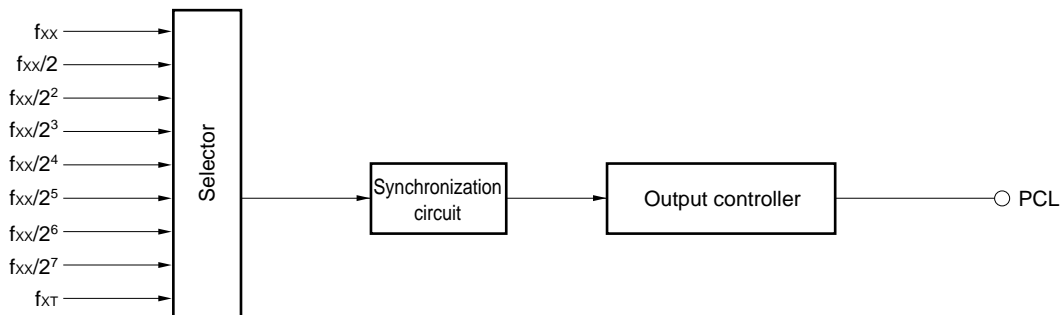

7.9 Buzzer Output Function

Clocks of the following frequencies can be output as buzzer output.

- 1.5 kHz/3.1 kHz/6.1 kHz/12.2 kHz (@12.5 MHz operation with main system clock)

Figure 7-15. Block Diagram of Buzzer Output Function

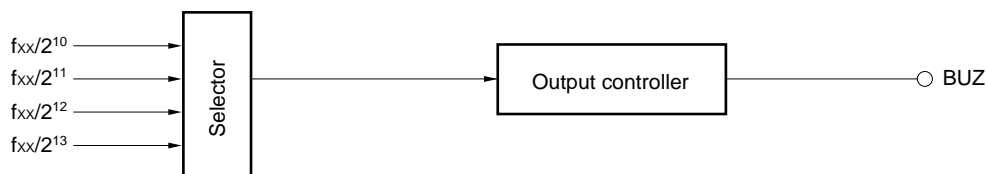

7.10 Edge Detection Function

The interrupt input pins (INTP0, INTP1, NMI/INTP2, INTP3 to INTP6) are used not only to input interrupt requests but also to input trigger signals to the internal hardware units. Because these pins operate at an edge of the input signal, they have a function to detect an edge. Moreover, a noise elimination function is also provided to prevent erroneous detection due to noise.

Pin Name	Detectable Edge	Noise Elimination
NMI	Either or both of rising and falling edges	By analog delay
INTP0 to INTP6		—

7.11 Watch Timer

The watch timer has the following functions:

- Watch timer
- Interval timer

The watch timer and interval timer functions can be used at the same time.

(1) Watch timer

The watch timer sets the WTIF flag of the interrupt control register (WTIC) at time intervals of 0.5 seconds by using the 32.768 kHz subsystem clock.

(2) Interval timer

The interval timer generates an interrupt request (INTTM3) at predetermined time intervals.

Figure 7-16. Block Diagram of Watch Timer

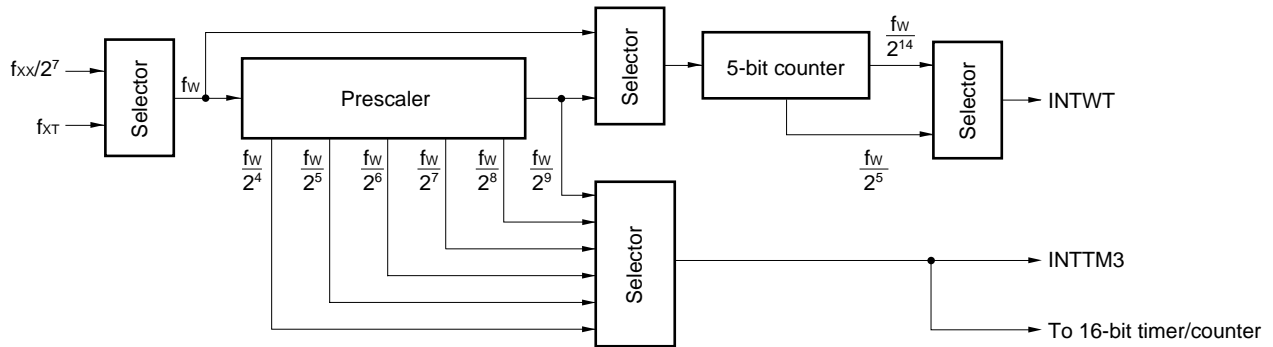

7.12 Watchdog Timer

A watchdog timer is provided to detect a CPU runaway. This watchdog timer generates a non-maskable or maskable interrupt unless it is cleared by software within a specified interval time. Once enabled to operate, the watchdog timer cannot be stopped by software. Whether the interrupt by the watchdog timer or the interrupt input from the NMI pin takes precedence can be specified.

Figure 7-17. Block Diagram of Watchdog Timer

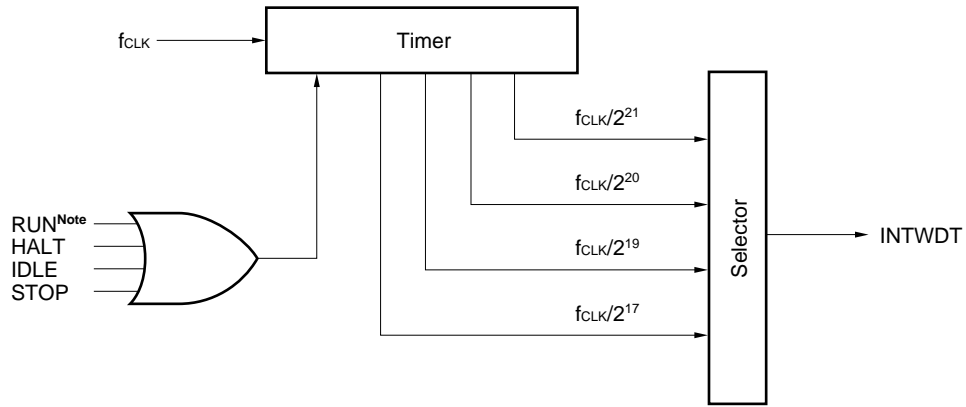

Note Write “+” to bit 7 (RUN) of the watchdog timer (WDM)

Remark fCLK: Internal system clock (fxx to fxx/8)

8. INTERRUPT FUNCTIONS

The three types of interrupt request servicing shown in Table 8-1 can be selected by program.

Table 8-1. Servicing of Interrupt Request

Servicing Mode	Entity of Servicing	Servicing	Contents of PC and PSW
Vectored interrupt	Software	Branches and executes servicing routine (servicing is arbitrary)	Saves to and restores from stack
Context switching		Automatically switches register bank, branches and executes servicing routine (servicing is arbitrary)	Saves to or restores from fixed area in register bank
Macro service	Firmware	Executes data transfer between memory and I/O (servicing is fixed)	Retained

8.1 Interrupt Sources

Table 8-2 shows the interrupt sources available. As shown, interrupts are generated by 29 types of sources, execution of the BRK instruction, BRKCS instruction, or an operand error.

The priority of interrupt servicing can be set to four levels, so that nesting can be controlled during interrupt servicing and so that which of the two or more interrupts that simultaneously occur should be serviced first can be determined. When the macro service function is used, however, nesting always proceeds.

The default priority is the priority (fixed) of the service that is performed if two or more interrupt requests, having the same priority, are simultaneously generated (refer to **Table 8-2**).

Table 8-2. Interrupt Sources (1/2)

Type	Default Priority	Source		Internal/ External	Macro Service
		Name	Trigger		
Software	-	BRK instruction	Instruction execution	-	-
		BRKCS instruction	Instruction execution		
		Operand error	If result of exclusive OR between operands byte and byte is not FFH when "MOV STBC, #byte" instruction, "MOV WDM, #byte" instruction, or LOCATION instruction is executed		
Non-maskable	-	NMI	Pin input edge detection	External	-
		INTWDT	Overflow of watchdog timer	Internal	
Maskable	0 (highest)	INTWDTM	Overflow of watchdog timer	Internal	√
	1	INTP0	Pin input edge detection	External	
	2	INTP1			
	3	INTP2			
	4	INTP3			
	5	INTP4			
	6	INTP5			
	7	INTP6			
	8	INTIIC0	End of I ² C bus transfer by CSI0	Internal	
		INTCSI0	End of 3-wire transfer by CSI0		
9	INTSER1	Occurrence of UART reception error in ASI1			

Table 8-2. Interrupt Sources (2/2)

Type	Default Priority	Source		Internal/ External	Macro Service	
		Name	Trigger			
Maskable	10	INTSR1	End of UART reception by ASI1	Internal	√	
		INTCSI1	End of 3-wire transfer by CSI1			
	11	INTST1	End of UART transmission by ASI1			
	12	INTSER2	Occurrence of UART reception error in ASI2			
	13	INTSR2	End of UART reception by ASI2			
		INTCSI2	End of 3-wire transfer by CSI2			
	14	INTST2	End of UART transmission by ASI2			
	15	INTTM3	Reference time interval signal from watch timer			
	16	INTTM00	Signal indicating match between 16-bit timer counter and capture/compare register (CR00)			
	17	INTTM01	Signal indicating match between 16-bit timer counter and capture/compare register (CR01)			
	18	INTTM1	Occurrence of match signal of 8-bit timer/event counter 1			
	19	INTTM2	Occurrence of match signal of 8-bit timer/event counter 2			
	20	INTAD	End of conversion by A/D converter			
	21	INTTM5	Occurrence of match signal of 8-bit timer/event counter 5			
	22	INTTM6	Occurrence of match signal of 8-bit timer/event counter 6			
	23	INTTM7	Occurrence of match signal of 8-bit timer/event counter 7			
	24	INTTM8	Occurrence of match signal of 8-bit timer/event counter 8			
	25	INTWT	Overflow of watch timer			
	26 (lowest)	INTKR	Detection of falling edge of port 8			External

Remarks 1. ASI: Asynchronous Serial Interface

CSI: Clocked Serial Interface

2. There are two interrupt sources for the watchdog timer: non-maskable interrupts (INTWDT) and maskable interrupts (INTWDTM). Either one (but not both) should be selected for actual use.

8.2 Vectored Interrupt

Execution branches to a servicing routine by using the memory contents of a vector table address corresponding to the interrupt source as the address of the branch destination.

So that the CPU performs interrupt servicing, the following operations are performed:

- On branching: Saves the status of the CPU (contents of PC and PSW) to stack
- On returning: Restores the status of the CPU (contents of PC and PSW) from stack

To return to the main routine from an interrupt service routine, the RETI instruction is used.

The branch destination address is in a range of 0 to FFFFH.

Table 8-3. Vector Table Address

Interrupt Source	Vector Table Address	Interrupt Source	Vector Table Address
BRK instruction	003EH	INTST1	001CH
TRAP0 (operand error)	003CH	INTSER2	001EH
NMI	0002H	INSR2	0020H
INTWDT (non-maskable)	0004H	INTCSI2	
INTWDTM (maskable)	0006H	INTST2	0022H
INTP0	0008H	INTTM3	0024H
INTP1	000AH	INTTM00	0026H
INTP2	000CH	INTTM01	0028H
INTP3	000EH	INTTM1	002AH
INTP4	0010H	INTTM2	002CH
INTP5	0012H	INTAD	002EH
INTP6	0014H	INTTM5	0030H
INTIIC0	0016H	INTTM6	0032H
INTCSI0		INTTM7	0034H
INTSER1	0018H	INTTM8	0036H
INTSR1	001AH	INTWT	0038H
INTCSI1		INTKR	003AH

8.3 Context Switching

When an interrupt request is generated or when the BRKCS instruction is executed, a predetermined register bank is selected by hardware. Context switching is a function that branches execution to a vector address stored in advance in the register bank, while at the same time stacking the current contents of the program counter (PC) and program status word (PSW) to the register bank.

The branch address is in a range of 0 to FFFFH.

Figure 8-1. Context Switching Operation When Interrupt Request Is Generated

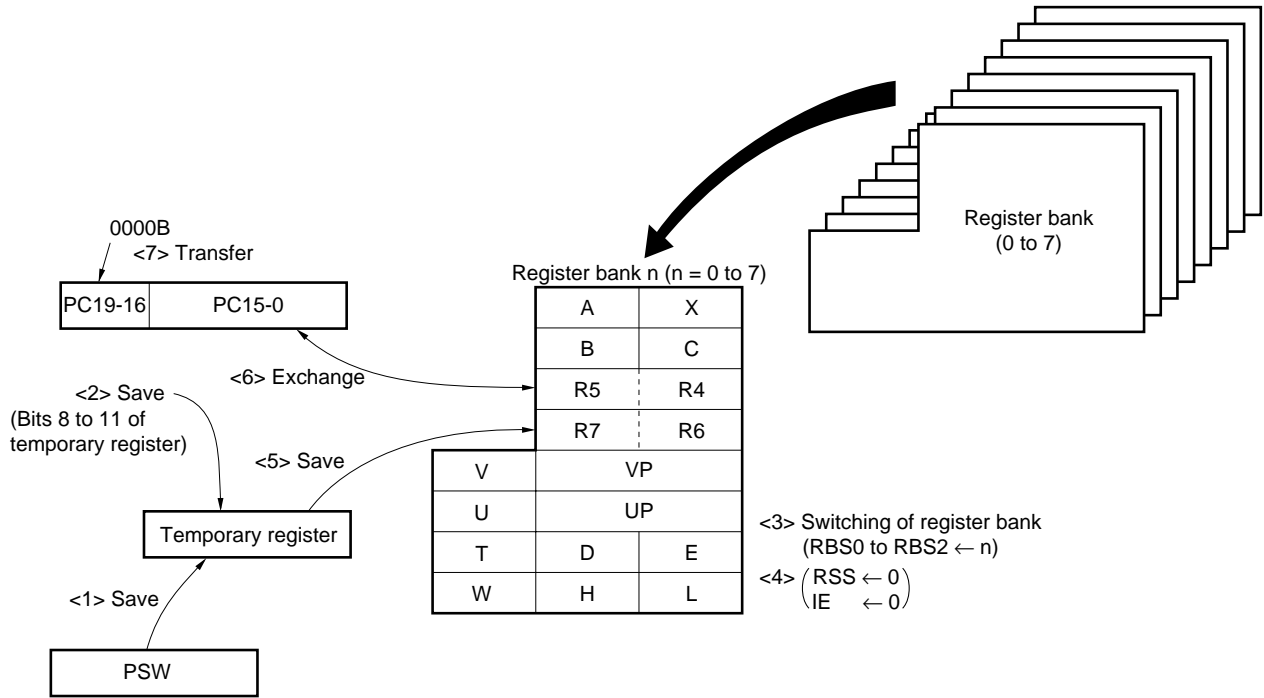

8.4 Macro Service

This function is to transfer data between memory and a special function register (SFR) without intervention by the CPU. A macro service controller accesses the memory and SFR in the same transfer cycle and directly transfers data without loading it.

Because this function does not save or restore the status of the CPU, or load data, data can be transferred at high speeds.

Figure 8-2. Macro Service

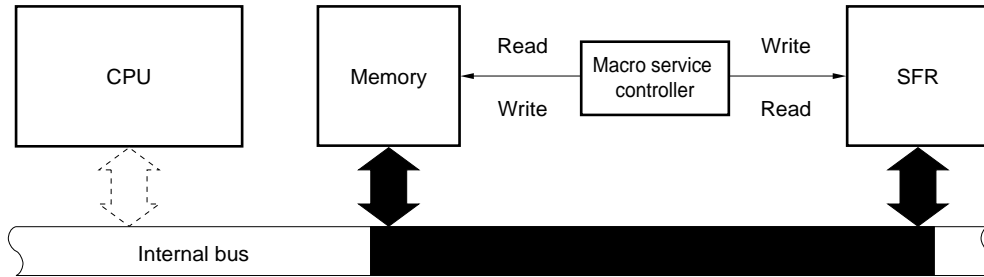

8.5 Application Example of Macro Service

(1) Serial interface transmission

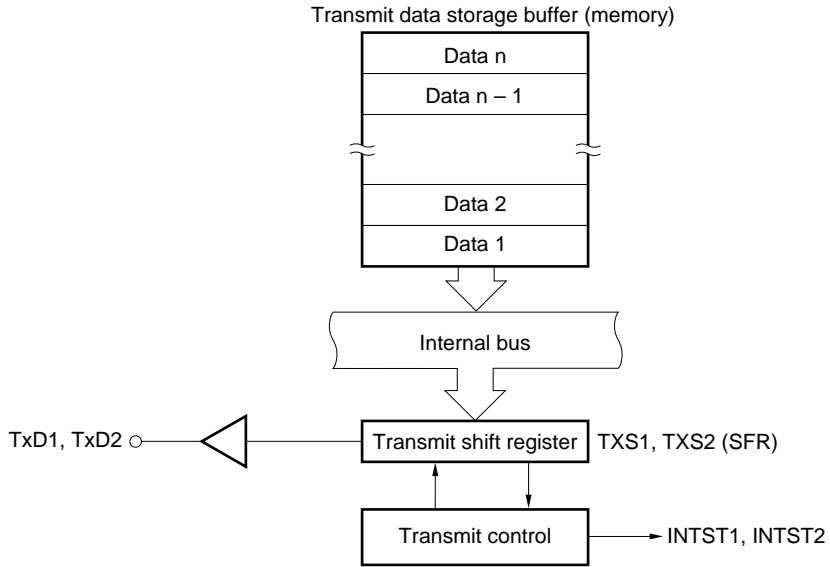

Each time macro service requests INTST1 and INTST2 are generated, the next transmit data is transferred from memory to TXS1 and TXS2. When data n (last byte) has been transferred to TXS1 and TXS2 (when the transmit data storage buffer has become empty), vectored interrupt requests INTST1 and INTST2 are generated.

(2) Serial interface reception

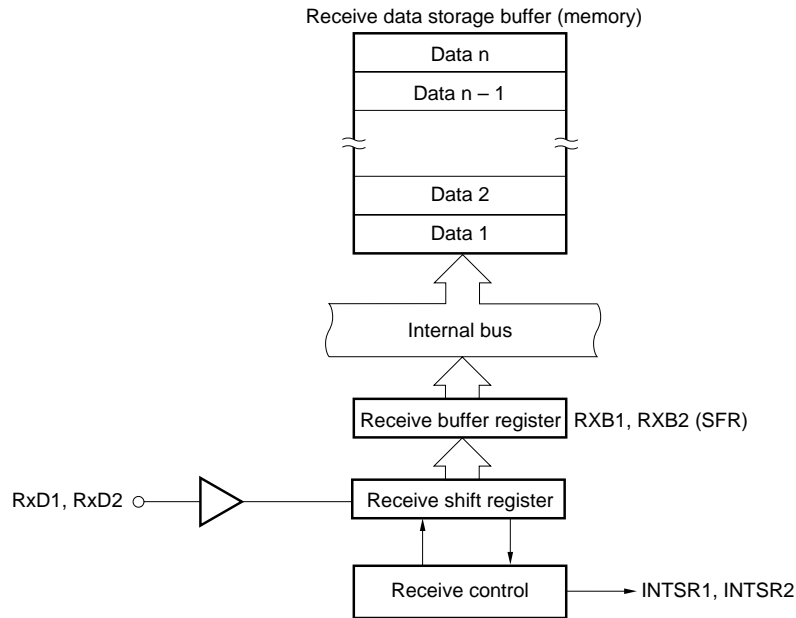

Each time macro service requests INTSR1 and INTSR2 are generated, the receive data is transferred from RXB1 and RXB2 to memory. When data n (last byte) has been transferred to memory (when the receive data storage buffer has become full), vectored interrupt requests INTSR1 and INTSR2 are generated.

9. LOCAL BUS INTERFACE

The local bus interface can connect an external memory or I/O (memory mapped I/O) and support a memory space of 1 MB (refer to **Figure 9-1**).

Figure 9-1. Example of Local Bus Interface

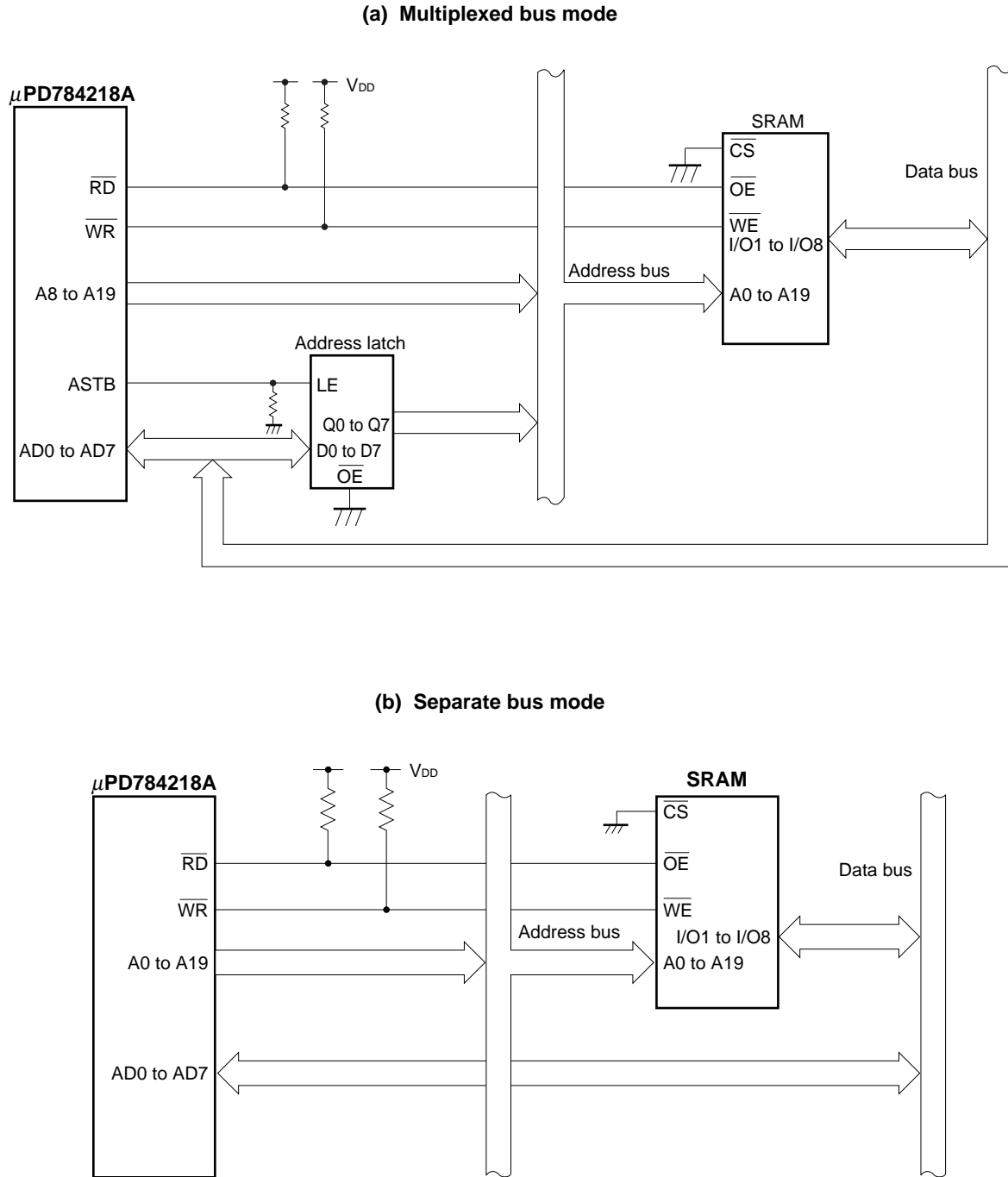

9.1 Memory Expansion

External program memory and data memory can be connected in two stages: 256 KB and 1 MB.

To connect the external memory, ports 4 through 6 and port 8 are used.

The external memory can be connected in the following two modes:

- Multiplexed bus mode: The external memory is connected by using a time-division address/data bus. The number of ports used when the external memory is connected can be reduced in this mode.
- Separate bus mode: The external memory is connected by using an address bus and data bus independent of each other. Because an external latch circuit is not necessary, this mode is useful for reducing the number of components and mounting area on the printed wiring board.

9.2 Programmable Wait

Wait state(s) can be inserted to the memory space (00000H to FFFFFH) while the \overline{RD} and \overline{WR} signals are active.

In addition, there is an address wait function that extends the active period of the ASTB signal to gain the address decode time.

10. STANDBY FUNCTION

This function is to reduce the power consumption of the chip, and can be used in the following modes:

- HALT mode: Stops supply of the operating clock to the CPU. This mode is used in combination with the normal operation mode for intermittent operation to reduce the average power consumption.
- IDLE mode: Stops the entire system except for the oscillator, which continues operating. The power consumption in this mode is close to that in the STOP mode.
However, the time required to restore the normal program operation from this mode is almost the same as that from the HALT mode.
- STOP mode: Stops the main system clock and thereby stops all the internal operations of the chip. Consequently, the power consumption is minimized with only leakage current flowing.
- Low power consumption mode: The main system clock is stopped and the subsystem clock is used as the system clock. The CPU can operate on the subsystem clock to reduce the current consumption.
- Low power consumption HALT mode: This is a standby function in the low power consumption mode and stops the operation clock of the CPU, to reduce the power consumption of the entire system.
- Low power consumption IDLE mode: This is a standby function in the low power consumption mode and stops the entire system except the oscillator, to reduce the power consumption of the entire system.

These modes are programmable.

The macro service can be started from the HALT mode or low power consumption HALT mode. After macro service processing is executed, the system returns to the HALT mode again.

The transition of the standby status is shown in Figure 10-1.

Figure 10-1. Standby Function State Transitions

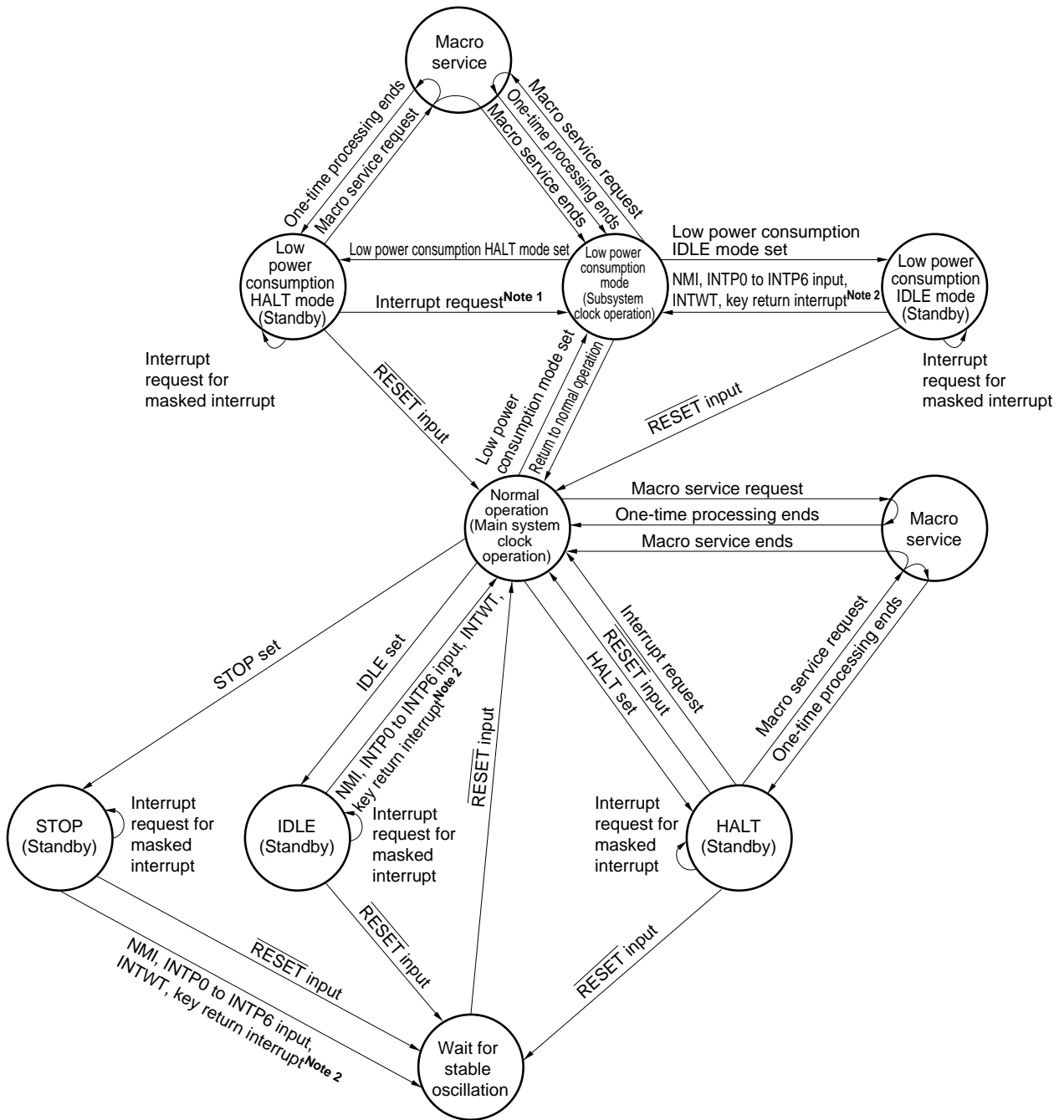

- Notes**
1. Only unmasked interrupt requests
 2. Only unmasked INTP0 to INTP6, INTWT, key return interrupt (P80 to P87)

Remark NMI is valid only for an external input. The watchdog timer cannot be used for the release of standby (HALT mode/STOP mode/IDLE mode).

11. RESET FUNCTION

When a low-level signal is input to the $\overline{\text{RESET}}$ pin, the system is reset, and each hardware unit is initialized (reset). During the reset period, oscillation of the main system clock is unconditionally stopped. Consequently, the current consumption of the entire system can be reduced.

When the $\overline{\text{RESET}}$ signal goes high, the reset status is cleared. And after the oscillation stabilization time (84.0 ms at 12.5 MHz operation) elapses, the contents of the reset vector table are set to the program counter (PC), execution branches to an address set to the PC, and program execution is started from that branch address. Therefore, the program can be reset and started from any address.

Figure 11-1. Oscillation of Main System Clock During Reset Period

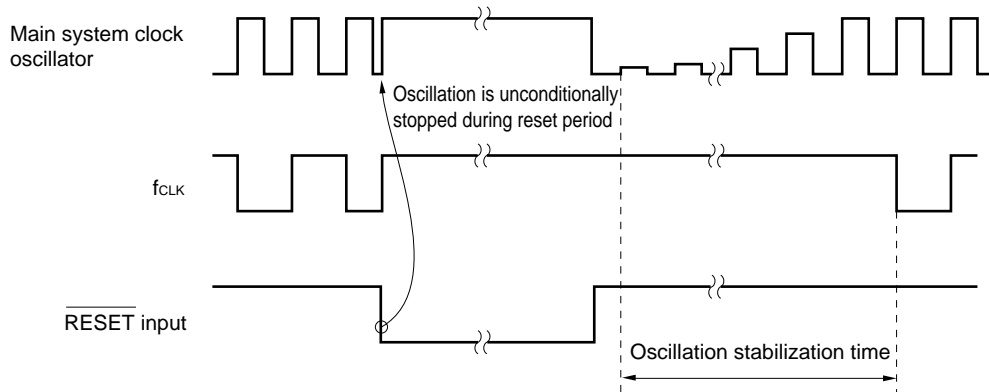

The $\overline{\text{RESET}}$ input pin has an analog delay noise eliminator to prevent malfunctioning due to noise.

Figure 11-2. Acknowledgement of Reset Signal

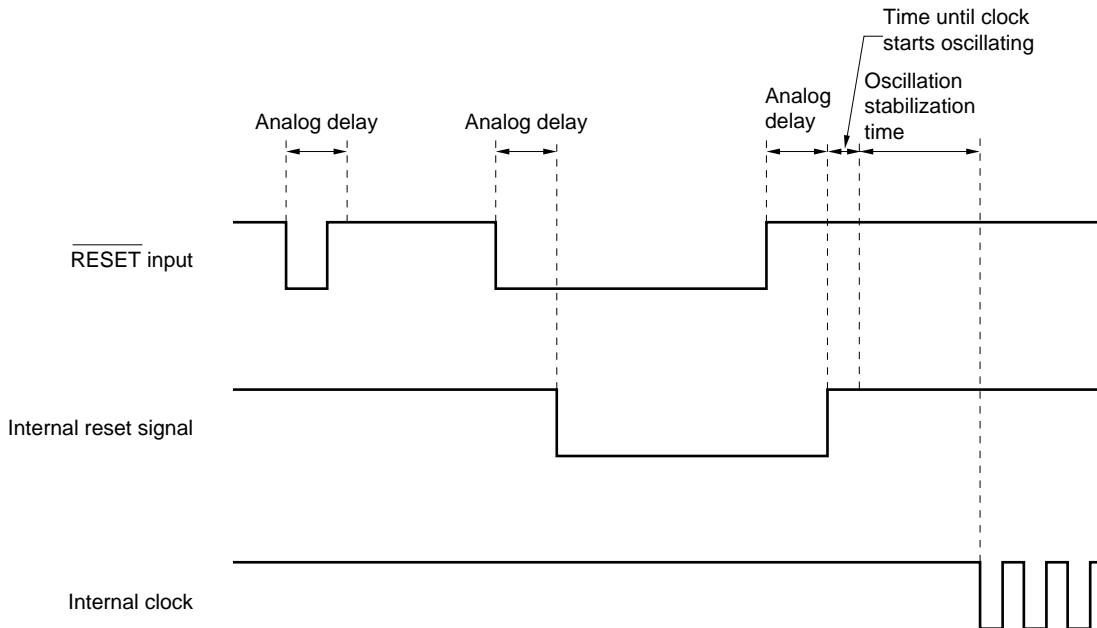

12. INSTRUCTION SET

(1) 8-bit instructions (instructions in parentheses are combinations realized by describing A as r)

MOV, XCH, ADD, ADDC, SUB, SUBC, AND, OR, XOR, CMP, MULU, DIVUW, INC, DEC, ROR, ROL, RORC, ROLC, SHR, SHL, ROR4, ROL4, DBNZ, PUSH, POP, MOVVM, XCHM, CMPME, CMPMNE, CMPMNC, CMPMC, MOVBK, XCHBK, CMPBKE, CMPBKNE, CMPBKNC, CMPBKC

Table 12-1. Instruction List by 8-Bit Addressing

Second Operand First Operand	#byte	A	r r'	saddr saddr'	sfr	!addr16 !!addr24	mem [saddrp] [%saddrg]	r3 PSWL PSWH	[WHL+] [WHL-]	n	None ^{Note 2}
A	(MOV) ADD ^{Note 1}	(MOV) (XCH) (ADD) ^{Note 1}	MOV XCH (ADD) ^{Note 1}	(MOV) ^{Note 6} (XCH) ^{Note 6} (ADD) ^{Notes 1, 6}	MOV (XCH) (ADD) ^{Note 1}	(MOV) (XCH) ADD ^{Note 1}	MOV XCH ADD ^{Note 1}	MOV	(MOV) (XCH) (ADD) ^{Note 1}		
r	MOV ADD ^{Note 1}	(MOV) (XCH) (ADD) ^{Note 1}	MOV XCH ADD ^{Note 1}	MOV XCH ADD ^{Note 1}	MOV XCH ADD ^{Note 1}	MOV XCH				ROR ^{Note 3}	MULU DIVUW INC DEC
saddr	MOV ADD ^{Note 1}	(MOV) ^{Note 6} (ADD) ^{Note 1}	MOV ADD ^{Note 1}	MOV XCH ADD ^{Note 1}							INC DEC DBNZ
sfr	MOV ADD ^{Note 1}	MOV (ADD) ^{Note 1}	MOV ADD ^{Note 1}								PUSH POP
!addr16 !!addr24	MOV	(MOV) ADD ^{Note 1}	MOV								
mem [saddrp] [%saddrg]		MOV ADD ^{Note 1}									
mem3											ROR4 ROL4
r3 PSWL PSWH	MOV	MOV									
B, C											DBNZ
STBC, WDM	MOV										
[TDE+] [TDE-]		(MOV) ^{Note 6} (ADD) ^{Note 1} MOVVM ^{Note 4}							MOVBK ^{Note 5}		

- Notes**
- The operands of ADDC, SUB, SUBC, AND, OR, XOR, and CMP are the same as that of ADD.
 - Either the second operand is not used, or the second operand is not an operand address.
 - The operands of ROL, RORC, ROLC, SHR, and SHL are the same as that of ROR.
 - The operands of XCHM, CMPME, CMPMNE, CMPMNC, and CMPMC are the same as that of MOVVM.
 - The operands of XCHBK, CMPBKE, CMPBKNE, CMPBKNC, and CMPBKC are the same as that of MOVBK.
 - The code length of some instructions having saddr2 as saddr in this combination is short.

(2) 16-bit instructions (instructions in parentheses are combinations realized by describing AX as rp)

MOVW, XCHW, ADDW, SUBW, CMPW, MULUW, MULW, DIVUX, INCW, DECW, SHRW, SHLW, PUSH, POP, ADDWG, SUBWG, PUSHU, POPU, MOVTBLW, MACW, MACSW, SACW

Table 12-2. Instruction List by 16-Bit Addressing

Second Operand First Operand	#word	AX	rp rp'	saddrp saddrp'	sfrp	!addr16 !!addr24	mem [saddrp] [%saddrg]	[WHL+]	byte	n	None ^{Note 2}
AX	(MOVW) ADDW ^{Note 1}	(MOVW) (XCHW) (ADD) ^{Note 1}	(MOVW) (XCHW) (ADDW) ^{Note 1}	(MOVW) ^{Note 3} (XCHW) ^{Note 3} (ADDW) ^{Notes 1, 3}	MOVW (XCHW) (ADDW) ^{Note 1}	(MOVW) XCHW	MOVW XCHW	(MOVW) (XCHW)			
rp	MOVW ADDW ^{Note 1}	(MOVW) (XCHW) (ADDW) ^{Note 1}	MOVW XCHW ADDW ^{Note 1}	MOVW XCHW ADDW ^{Note 1}	MOVW XCHW ADDW ^{Note 1}	MOVW				SHRW SHLW	MULU ^{Note 4} INCW DECW
saddrp	MOVW ADDW ^{Note 1}	(MOVW) ^{Note 3} (ADDW) ^{Note 1}	MOVW ADDW ^{Note 1}	MOVW XCHW ADDW ^{Note 1}							INCW DECW
sfrp	MOVW ADDW ^{Note 1}	MOVW (ADDW) ^{Note 1}	MOVW ADDW ^{Note 1}								PUSH POP
!addr16 !!addr24	MOVW	(MOVW)	MOVW						MOVTBLW		
mem [saddrp] [%saddrg]		MOVW									
PSW											PUSH POP
SP	ADDWG SUBWG										
post											PUSH POP PUSHU POPU
[TDE+]		(MOVW)						SACW			
byte											MACW MACSW

- Notes**
1. The operands of SUBW and CMPW are the same as that of ADDW.
 2. Either the second operand is not used, or the second operand is not an operand address.
 3. The code length of some instructions having saddrp2 as saddrp in this combination is short.
 4. The operands of MULUW and DIVUX are the same as that of MULW.

(3) 24-bit instructions (instructions in parentheses are combinations realized by describing WHL as rg)

MOVG, ADDG, SUBG, INCG, DECG, PUSH, POP

Table 12-3. Instruction List by 24-Bit Addressing

Second Operand First Operand	#imm24	WHL	rg rg'	saddrg	!!addr24	mem1	[%saddrg]	SP	None ^{Note}
WHL	(MOVG) (ADDG) (SUBG)	(MOVG) (ADDG) (SUBG)	(MOVG) (ADDG) (SUBG)	(MOVG) ADDG SUBG	(MOVG)	MOVG	MOVG	MOVG	
rg	MOVG ADDG SUBG	(MOVG) (ADDG) (SUBG)	MOVG ADDG SUBG	MOVG	MOVG				INCG DECG PUSH POP
saddrg		(MOVG)	MOVG						
!!addr24		(MOVG)	MOVG						
mem1		MOVG							
[%saddrg]		MOVG							
SP	MOVG	MOVG							INCG DECG

Note Either the second operand is not used, or the second operand is not an operand address.

(4) Bit manipulation instructions

MOV1, AND1, OR1, XOR1, SET1, CLR1, NOT1, BT, BF, BTCLR, BFSET

Table 12-4. Instruction List by Bit Manipulation Instruction Addressing

Second Operand \ First Operand	CY	saddr.bit sfr.bit A.bit X.bit PSWL.bit PSWH.bit mem2.bit !addr16.bit !!addr24.bit	/saddr.bit /sfr. bit /A.bit /X.bit /PSWL.bit /PSWH.bit /mem2.bit /!addr16.bit /!!addr24.bit	None ^{Note}
CY		MOV1 AND1 OR1 XOR1	AND1 OR1	NOT1 SET1 CLR1
saddr.bit sfr.bit A.bit X.bit PSWL.bit PSWH.bit mem2.bit !addr16.bit !!addr24.bit	MOV1			NOT1 SET1 CLR1 BF BT BTCLR BFSET

Note Either the second operand is not used, or the second operand is not an operand address.

(5) Call and return/branch instructions

CALL, CALLF, CALLT, BRK, RET, RETI, RETB, RETCS, RETCSB, BRKCS, BR, BNZ, BNE, BZ, BE, BNC, BNL, BC, BL, BNV, BPO, BV, BPE, BP, BN, BLT, BGE, BLE, BGT, BNH, BH, BF, BT, BTCLR, BFSET, DBNZ

Table 12-5. Instruction List by Call and Return/Branch Instruction Addressing

Operand of Instruction Address	\$addr20	!addr20	!addr16	!!addr20	rp	rg	[rp]	[rg]	!addr11	[addr5]	RBn	None
Basic instruction	BC ^{Note} BR	CALL BR	CALL BR RETCS RETCSB	CALL BR	CALL BR	CALL BR	CALL BR	CALL BR	CALLF CALLF		BRKCS	BRK RET RETI RETB
Compound instruction	BF BT BTCLR BFSET DBNZ											

Note The operands of BNZ, BNE, BZ, BE, BNC, BNL, BL, BNV, BPO, BV, BPE, BP, BN, BLT, BGE, BLE, BGT, BNH, and BH are the same as that of BC.

(6) Other instructions

ADJBA, ADJBS, CVTBW, LOCATION, SEL, NOT, EI, DI, SWRS

13. ELECTRICAL SPECIFICATIONS

Absolute Maximum Ratings (T_A = 25°C)

Parameter	Symbol	Conditions		Ratings	Unit
Supply voltage	V _{DD}			-0.3 to +6.5	V
	AV _{DD}			-0.3 to V _{DD} + 0.3	V
	AV _{SS}			-0.3 to V _{SS} + 0.3	V
	AV _{REF0}	A/D converter reference voltage input		-0.3 to V _{DD} + 0.3	V
	AV _{REF1}	D/A converter reference voltage input		-0.3 to V _{DD} + 0.3	V
Input voltage	V _{I1}	Other than P90 to P95		-0.3 to V _{DD} + 0.3	V
	V _{I2}	P90 to P95	N-ch open drain	-0.3 to +12	V
Analog input voltage	V _{AN}	Analog input pin		AV _{SS} - 0.3 to AV _{REF0} + 0.3	V
Output voltage	V _O			-0.3 to V _{DD} + 0.3	V
Output current, low	I _{OL}	Per pin		15	mA
		Total of P2, P4 to P8		75	mA
		Total of P0, P3, P9, P10, P12, P13		75	mA
		Total of all pins		100	mA
Output current, high	I _{OH}	Per pin		-10	mA
		Total of all pins		-50	mA
Operating ambient temperature	T _A			-40 to +85	°C
Storage temperature	T _{stg}			-65 to +150	°C

Caution Product quality may suffer if the absolute maximum rating is exceeded even momentarily for any parameter. That is, the absolute maximum ratings are rated values at which the product is on the verge of suffering physical damage, and therefore the product must be used under conditions that ensure that the absolute maximum ratings are not exceeded.

Operating Conditions

- Operating ambient temperature (T_A): -40 to +85°C
- Power supply voltage and clock cycle time: See **Figure 13-1**
- Power supply voltage with subsystem clock operation: V_{DD} = 1.8 to 5.5 V

Figure 13-1. Power Supply Voltage and Clock Cycle Time (CPU Clock Frequency: f_{CPU})

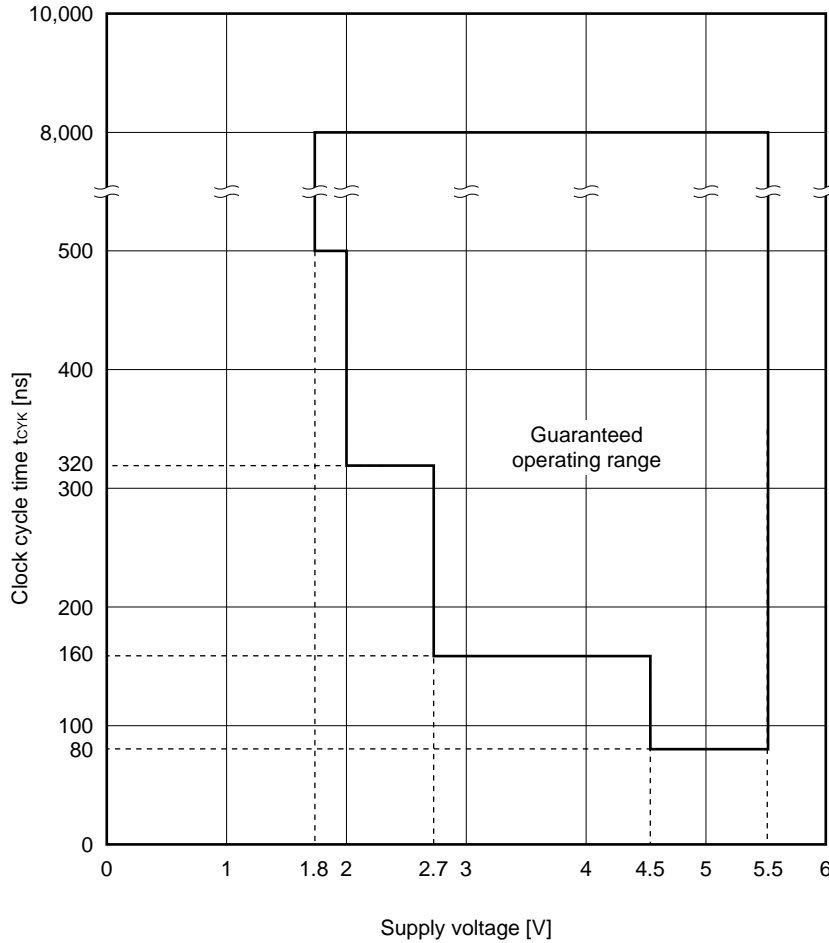

Capacitance (T_A = 25°C, V_{DD} = V_{SS} = 0 V)

Parameter	Symbol	Conditions	MIN.	TYP.	MAX.	Unit	
Input capacitance	C _i	f = 1 MHz Unmeasured pins returned to 0 V.	Other than Port 9			15	pF
			Port 9			20	pF
Output capacitance	C _o		Other than Port 9			15	pF
			Port 9			20	pF
I/O capacitance	C _{io}		Other than Port 9			15	pF
			Port 9			20	pF

Main System Clock Oscillator Characteristics (T_A = -40 to +85°C)

Resonator	Recommended Circuit	Parameter	Conditions	MIN.	TYP.	MAX.	Unit
Ceramic resonator or crystal resonator		Oscillation frequency (f _x)	4.5 V ≤ V _{DD} ≤ 5.5 V	2		12.5	MHz
			2.7 V ≤ V _{DD} < 4.5 V	2		6.25	
			2.0 V ≤ V _{DD} < 2.7 V	2		3.125	
			1.8 V ≤ V _{DD} < 2.0 V	2		2	
External clock		X1 input frequency (f _x)	4.5 V ≤ V _{DD} ≤ 5.5 V	2		12.5	MHz
			2.7 V ≤ V _{DD} < 4.5 V	2		6.25	
			2.0 V ≤ V _{DD} < 2.7 V	2		3.125	
			1.8 V ≤ V _{DD} < 2.0 V	2		2	
		X1 input high-/low-level width (t _{wXH} , t _{wXL})		15		250	ns
		X1 input rising/falling time (t _{xR} , t _{xF})	4.5 V ≤ V _{DD} ≤ 5.5 V	0		5	ns
			2.7 V ≤ V _{DD} < 4.5 V	0		10	
			2.0 V ≤ V _{DD} < 2.7 V	0		20	
1.8 V ≤ V _{DD} < 2.0 V	0			30			

Cautions 1. When using the main system clock oscillator, wire as follows in the area enclosed by the broken lines in the above figures to avoid an adverse effect from wiring capacitance.

- Keep the wiring length as short as possible.
- Do not cross the wiring with other signal lines.
- Do not route the wiring near a signal line through which a high fluctuating current flows.
- Always make the ground point of the oscillator capacitor the same potential as V_{SS}.
- Do not ground the capacitor to a ground pattern through which a high current flows.
- Do not fetch signals from the oscillator.

2. When the main system clock is stopped and the system is operated by the subsystem clock, the subsystem clock should be switched back to the main system clock after the oscillation stabilization time is secured by the program.

Remark For the resonator selection and oscillator constant, users are required to either evaluate the oscillation themselves or apply to the resonator manufacturer for evaluation.

Subsystem Clock Oscillator Characteristics (T_A = -40 to +85°C)

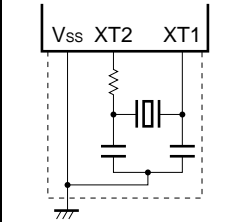
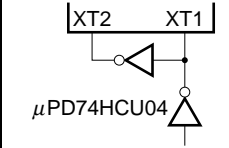
Resonator	Recommended Circuit	Parameter	Conditions	MIN.	TYP.	MAX.	Unit
Crystal resonator		Oscillation frequency (f _{XT})		32	32.768	35	kHz
		Oscillation stabilization time ^{Note}	4.5 V ≤ V _{DD} ≤ 5.5 V		1.2	2	s
			1.8 V ≤ V _{DD} < 4.5 V			10	
External clock		XT1 input frequency (f _{XT})		32		35	kHz
		XT1 input high-/low-level width (t _{XTH} , t _{XTL})		14.3		15.6	μs

Note Time required to stabilize oscillation after applying supply voltage (V_{DD}).

Cautions 1. When using the subsystem clock oscillator, wire as follows in the area enclosed by the broken lines in the above figures to avoid an adverse effect from wiring capacitance.

- Keep the wiring length as short as possible.
- Do not cross the wiring with other signal lines.
- Do not route the wiring near a signal line through which a high fluctuating current flows.
- Always make the ground point of the oscillator capacitor the same potential as V_{SS}.
- Do not ground the capacitor to a ground pattern through which a high current flows.
- Do not fetch signals from the oscillator.

2. When the main system clock is stopped and the device is operating on the subsystem clock, wait until the oscillation stabilization time has been secured by the program before switching back to the main system clock.

Remark For the resonator selection and oscillator constant, users are required to either evaluate the oscillation themselves or apply to the resonator manufacturer for evaluation.

DC Characteristics (T_A = -40 to +85°C, V_{DD} = AV_{DD} = 1.8 to 5.5 V, V_{SS} = AV_{SS} = 0 V) (1/3)

Parameter	Symbol	Conditions	MIN.	TYP.	MAX.	Unit		
Input voltage, low	V _{IL1}	Note 1	2.2 V ≤ V _{DD} ≤ 5.5 V	0		0.3V _{DD}	V	
			1.8 V ≤ V _{DD} < 2.2 V	0		0.2V _{DD}		
	V _{IL2}	P00 to P06, P20, P22, P33, P34, P70, P72, P100 to P103, RESET	2.2 V ≤ V _{DD} ≤ 5.5 V	0		0.2V _{DD}	V	
			1.8 V ≤ V _{DD} < 2.2 V	0		0.15V _{DD}		
	V _{IL3}	P90 to P95 (N-ch open drain)	2.2 V ≤ V _{DD} ≤ 5.5 V	0		0.3V _{DD}	V	
			1.8 V ≤ V _{DD} < 2.2 V	0		0.2V _{DD}		
	V _{IL4}	P10 to P17, P130, P131	2.2 V ≤ V _{DD} ≤ 5.5 V	0		0.3V _{DD}	V	
			1.8 V ≤ V _{DD} < 2.2 V	0		0.2V _{DD}		
	V _{IL5}	X1, X2, XT1, XT2	2.2 V ≤ V _{DD} ≤ 5.5 V	0		0.2V _{DD}	V	
			1.8 V ≤ V _{DD} < 2.2 V	0		0.1V _{DD}		
	V _{IL6}	P25, P27	2.2 V ≤ V _{DD} ≤ 5.5 V	0		0.3V _{DD}	V	
			1.8 V ≤ V _{DD} < 2.2 V	0		0.2V _{DD}		
Input voltage, high	V _{IH1}	Note 1	2.2 V ≤ V _{DD} ≤ 5.5 V	0.7V _{DD}		V _{DD}	V	
			1.8 V ≤ V _{DD} < 2.2 V	0.8V _{DD}		V _{DD}		
	V _{IH2}	P00 to P06, P20, P22, P33, P34, P70, P72, P100 to P103, RESET	2.2 V ≤ V _{DD} ≤ 5.5 V	0.8V _{DD}		V _{DD}	V	
			1.8 V ≤ V _{DD} < 2.2 V	0.85V _{DD}		V _{DD}		
	V _{IH3}	P90 to P95 (N-ch open drain)	2.2 V ≤ V _{DD} ≤ 5.5 V	0.7V _{DD}		12	V	
			1.8 V ≤ V _{DD} < 2.2 V	0.8V _{DD}		V _{DD}		
	V _{IH4}	P10 to P17, P130, P131	2.2 V ≤ V _{DD} ≤ 5.5 V	0.7V _{DD}		V _{DD}	V	
			1.8 V ≤ V _{DD} < 2.2 V	0.8V _{DD}		V _{DD}		
	V _{IH5}	X1, X2, XT1, XT2	2.2 V ≤ V _{DD} ≤ 5.5 V	0.8V _{DD}		V _{DD}	V	
			1.8 V ≤ V _{DD} < 2.2 V	0.85V _{DD}		V _{DD}		
	V _{IH6}	P25, P27	2.2 V ≤ V _{DD} ≤ 5.5 V	0.7V _{DD}		V _{DD}	V	
			1.8 V ≤ V _{DD} < 2.2 V	0.8V _{DD}		V _{DD}		
Output voltage, low	V _{OL1}	For pins other than P40 to P47, P50 to P57, P90 to P95 I _{OL} = 1.6 mA ^{Note 1}	4.5 V ≤ V _{DD} ≤ 5.5 V			0.4	V	
			P40 to P47, P50 to P57 I _{OL} = 8 mA ^{Note 2}	4.5 V ≤ V _{DD} ≤ 5.5 V				1.0
			P90 to P95 I _{OL} = 15 mA ^{Note 2}	4.5 V ≤ V _{DD} ≤ 5.5 V		0.8		2.0
	V _{OL2}	I _{OL} = 400 μA ^{Note 2}				0.5	V	
Output voltage, high	V _{OH1}	I _{OH} = -1 mA ^{Note 2} I _{OL} = -100 μA ^{Note 2}	4.5 V ≤ V _{DD} ≤ 5.5 V	V _{DD} - 1.0			V	
				V _{DD} - 0.5			V	
Input leakage current, low	I _{LIL1}	V _{IN} = 0 V	Except X1, X2, XT1, XT2			-3	μA	
	I _{LIL2}		X1, X2, XT1, XT2			-20	μA	
Input leakage current, high	I _{LIH1}	V _{IN} = V _{DD}	Except X1, X2, XT1, XT2			3	μA	
	I _{LIH2}		X1, X2, XT1, XT2			20	μA	
	I _{LIH3}	V _{IN} = 12 V (N-ch open drain)	P90 to P95			20	μA	
Output leakage current, low	I _{LOL1}	V _{OUT} = 0 V				-3	μA	
Output leakage current, high	I _{LOH1}	V _{OUT} = V _{DD}				3	μA	

Notes 1. P21, P23, P24, P26, P30 to P32, P35 to P37, P40 to P47, P50 to P57, P60 to P67, P71, P80 to P87, P120 to P127

2. Per pin

DC Characteristics (T_A = -40 to +85°C, V_{DD} = AV_{DD} = 1.8 to 5.5 V, V_{SS} = AV_{SS} = 0 V) (2/3)

★ (1) μPD784214A, 784215A, 784216A, 784214AY, 784215AY, 784216AY

Parameter	Symbol	Conditions	MIN.	TYP.	MAX.	Unit	
Supply current	I _{DD1}	Operation mode	f _{XX} = 12.5 MHz, V _{DD} = 5.0 V ±10%		11	40	mA
			f _{XX} = 6 MHz, V _{DD} = 3.0 V ±10%		3	17	mA
			f _{XX} = 2 MHz, V _{DD} = 2.0 V ±10%		1	8	mA
	I _{DD2}	HALT mode	f _{XX} = 12.5 MHz, V _{DD} = 5.0 V ±10%		5	20	mA
			f _{XX} = 6 MHz, V _{DD} = 3.0 V ±10%		2	8	mA
			f _{XX} = 2 MHz, V _{DD} = 2.0 V ±10%		0.3	3.5	mA
	I _{DD3}	IDLE mode	f _{XX} = 12.5 MHz, V _{DD} = 5.0 V ±10%		1	2.5	mA
			f _{XX} = 6 MHz, V _{DD} = 3.0 V ±10%		0.4	1.3	mA
			f _{XX} = 2 MHz, V _{DD} = 2.0 V ±10%		0.2	0.9	mA
	I _{DD4}	Operation mode ^{Note}	f _{XX} = 32 kHz, V _{DD} = 5.0 V ±10%		80	200	μA
			f _{XX} = 32 kHz, V _{DD} = 3.0 V ±10%		60	110	μA
			f _{XX} = 32 kHz, V _{DD} = 2.0 V ±10%		30	100	μA
I _{DD5}	HALT mode ^{Note}	f _{XX} = 32 kHz, V _{DD} = 5.0 V ±10%		60	160	μA	
		f _{XX} = 32 kHz, V _{DD} = 3.0 V ±10%		20	80	μA	
		f _{XX} = 32 kHz, V _{DD} = 2.0 V ±10%		10	70	μA	
I _{DD6}	IDLE mode ^{Note}	f _{XX} = 32 kHz, V _{DD} = 5.0 V ±10%		50	150	μA	
		f _{XX} = 32 kHz, V _{DD} = 3.0 V ±10%		15	70	μA	
		f _{XX} = 32 kHz, V _{DD} = 2.0 V ±10%		5	60	μA	
Data retention voltage	V _{DDDR}	HALT, IDLE modes	1.8		5.5	V	
Data retention current	I _{DDDR}	STOP mode	V _{DD} = 2.0 V ±10%		2	10	μA
			V _{DD} = 5.0 V ±10%		10	50	μA
Pull-up resistor	R _L	V _{IN} = 0 V	10	30	100	kΩ	

Note When main system clock is stopped and subsystem clock is operating.

Remark Unless otherwise specified, the characteristics of alternate-function pins are the same as those of port pins.

DC Characteristics (T_A = -40 to +85°C, V_{DD} = AV_{DD} = 1.8 to 5.5 V, V_{SS} = AV_{SS} = 0 V) (3/3)

★(2) μPD784217A, 784218A, 784217AY, 784218AY

Parameter	Symbol	Conditions	MIN.	TYP.	MAX.	Unit	
Supply current	I _{DD1}	Operation mode	f _{XX} = 12.5 MHz, V _{DD} = 5.0 V ±10%		11	40	mA
			f _{XX} = 6 MHz, V _{DD} = 3.0 V ±10%		4	17	mA
			f _{XX} = 2 MHz, V _{DD} = 2.0 V ±10%		1	8	mA
	I _{DD2}	HALT mode	f _{XX} = 12.5 MHz, V _{DD} = 5.0 V ±10%		6	20	mA
			f _{XX} = 6 MHz, V _{DD} = 3.0 V ±10%		2	8	mA
			f _{XX} = 2 MHz, V _{DD} = 2.0 V ±10%		0.4	3.5	mA
	I _{DD3}	IDLE mode	f _{XX} = 12.5 MHz, V _{DD} = 5.0 V ±10%		1	2.5	mA
			f _{XX} = 6 MHz, V _{DD} = 3.0 V ±10%		0.4	1.3	mA
			f _{XX} = 2 MHz, V _{DD} = 2.0 V ±10%		0.2	0.9	mA
	I _{DD4}	Operation mode ^{Note}	f _{XX} = 32 kHz, V _{DD} = 5.0 V ±10%		80	200	μA
			f _{XX} = 32 kHz, V _{DD} = 3.0 V ±10%		60	110	μA
			f _{XX} = 32 kHz, V _{DD} = 2.0 V ±10%		30	100	μA
	I _{DD5}	HALT mode ^{Note}	f _{XX} = 32 kHz, V _{DD} = 5.0 V ±10%		60	160	μA
			f _{XX} = 32 kHz, V _{DD} = 3.0 V ±10%		20	80	μA
			f _{XX} = 32 kHz, V _{DD} = 2.0 V ±10%		10	70	μA
I _{DD6}	IDLE mode ^{Note}	f _{XX} = 32 kHz, V _{DD} = 5.0 V ±10%		50	150	μA	
		f _{XX} = 32 kHz, V _{DD} = 3.0 V ±10%		15	70	μA	
		f _{XX} = 32 kHz, V _{DD} = 2.0 V ±10%		5	60	μA	
Data retention voltage	V _{DDDR}	HALT, IDLE modes	1.8		5.5	V	
Data retention current	I _{DDDR}	STOP mode	V _{DD} = 2.0 V ±10%		2	10	μA
			V _{DD} = 5.0 V ±10%		10	50	μA
Pull-up resistor	R _L	V _{IN} = 0 V	10	30	100	kΩ	

Note When main system clock is stopped and subsystem clock is operating.

Remark Unless otherwise specified, the characteristics of alternate-function pins are the same as those of port pins.

AC Characteristics (T_A = -40 to +85°C, V_{DD} = AV_{DD} = 1.8 to 5.5 V, V_{SS} = AV_{SS} = 0 V)

(1) Read/write operation (1/2)

Parameter	Symbol	Conditions	MIN.	TYP.	MAX.	Unit
Cycle time	t _{CYK}	4.5 V ≤ V _{DD} ≤ 5.5 V	80			ns
		2.7 V ≤ V _{DD} < 4.5 V	160			ns
		2.0 V ≤ V _{DD} < 2.7 V	320			ns
		1.8 V ≤ V _{DD} < 2.0 V	500			ns
Address setup time (to ASTB↓)	t _{SAST}	V _{DD} = 5.0 V ±10%	(0.5 + a)T - 20			ns
		V _{DD} = 3.0 V ±10%	(0.5 + a)T - 40			ns
		V _{DD} = 2.0 V ±10%	(0.5 + a)T - 80			ns
Address hold time (from ASTB↓)	t _{HSTLA}	V _{DD} = 5.0 V ±10%	0.5T - 19			ns
		V _{DD} = 3.0 V ±10%	0.5T - 24			ns
		V _{DD} = 2.0 V ±10%	0.5T - 34			ns
ASTB high-level width	t _{WSTH}	V _{DD} = 5.0 V ±10%	(0.5 + a)T - 17			ns
		V _{DD} = 3.0 V ±10%	(0.5 + a)T - 40			ns
		V _{DD} = 2.0 V ±10%	(0.5 + a)T - 110			ns
Address hold time (from RD↑)	t _{HRA}	V _{DD} = 5.0 V ±10%	0.5T - 14			ns
		V _{DD} = 3.0 V ±10%	0.5T - 14			ns
		V _{DD} = 2.0 V ±10%	0.5T - 14			ns
Delay time from address to RD↓	t _{DAR}	V _{DD} = 5.0 V ±10%	(1 + a)T - 24			ns
		V _{DD} = 3.0 V ±10%	(1 + a)T - 35			ns
		V _{DD} = 2.0 V ±10%	(1 + a)T - 80			ns
Address float time (from RD↓)	t _{FAR}	V _{DD} = 5.0 V ±10%			0	ns
		V _{DD} = 3.0 V ±10%			0	ns
		V _{DD} = 2.0 V ±10%			0	ns
Data input time from address	t _{DAID}	V _{DD} = 5.0 V ±10%			(2.5 + a + n)T - 37	ns
		V _{DD} = 3.0 V ±10%			(2.5 + a + n)T - 52	ns
		V _{DD} = 2.0 V ±10%			(2.5 + a + n)T - 120	ns
Data input time from ASTB↓	t _{DSTID}	V _{DD} = 5.0 V ±10%			(2 + n)T - 35	ns
		V _{DD} = 3.0 V ±10%			(2 + n)T - 50	ns
		V _{DD} = 2.0 V ±10%			(2 + n)T - 80	ns
Data input time from RD↓	t _{DRID}	V _{DD} = 5.0 V ±10%			(1.5 + n)T - 40	ns
		V _{DD} = 3.0 V ±10%			(1.5 + n)T - 50	ns
		V _{DD} = 2.0 V ±10%			(1.5 + n)T - 90	ns
Delay time from ASTB↓ to RD↓	t _{DSTR}	V _{DD} = 5.0 V ±10%	0.5T - 9			ns
		V _{DD} = 3.0 V ±10%	0.5T - 9			ns
		V _{DD} = 2.0 V ±10%	0.5T - 20			ns
Data hold time (from RD↑)	t _{HRID}	V _{DD} = 5.0 V ±10%	0			ns
		V _{DD} = 3.0 V ±10%	0			ns
		V _{DD} = 2.0 V ±10%	0			ns

★

Remark T: t_{CYK} = 1/f_{XX} (f_{XX}: main system clock frequency)

a: 1 (during address wait), otherwise, 0

n: Number of waits (n ≥ 0)

AC Characteristics

(1) Read/write operation (2/2)

Parameter	Symbol	Conditions	MIN.	TYP.	MAX.	Unit
Address active time from $\overline{RD}\uparrow$	tDRA	V _{DD} = 5.0 V ±10%	0.5T - 2			ns
		V _{DD} = 3.0 V ±10%	0.5T - 12			ns
		V _{DD} = 2.0 V ±10%	0.5T - 35			ns
Delay time from $\overline{RD}\uparrow$ to ASTB \uparrow	tDRST	V _{DD} = 5.0 V ±10%	0.5T - 9			ns
		V _{DD} = 3.0 V ±10%	0.5T - 9			ns
		V _{DD} = 2.0 V ±10%	0.5T - 40			ns
\overline{RD} low-level width	tWRL	V _{DD} = 5.0 V ±10%	(1.5 + n)T - 25			ns
		V _{DD} = 3.0 V ±10%	(1.5 + n)T - 30			ns
		V _{DD} = 2.0 V ±10%	(1.5 + n)T - 25			ns
Delay time from address to $\overline{WR}\downarrow$	tDAW	V _{DD} = 5.0 V ±10%	(1 + a)T - 24			ns
		V _{DD} = 3.0 V ±10%	(1 + a)T - 34			ns
		V _{DD} = 2.0 V ±10%	(1 + a)T - 70			ns
Address hold time (from $\overline{WR}\uparrow$)	tHRD	V _{DD} = 5.0 V ±10%	0.5T - 14			ns
		V _{DD} = 3.0 V ±10%	0.5T - 14			ns
		V _{DD} = 2.0 V ±10%	0.5T - 14			ns
Delay time from ASTB \downarrow to data output	tDSTOD	V _{DD} = 5.0 V ±10%			0.5T + 15	ns
		V _{DD} = 3.0 V ±10%			0.5T + 30	ns
		V _{DD} = 2.0 V ±10%			0.5T + 240	ns
Delay time from $\overline{WR}\downarrow$ to data output	tDWOD	V _{DD} = 5.0 V ±10%			0.5T - 30	ns
		V _{DD} = 3.0 V ±10%			0.5T - 30	ns
		V _{DD} = 2.0 V ±10%			0.5T - 30	ns
Delay time from ASTB \downarrow to $\overline{WR}\downarrow$	tDSTW	V _{DD} = 5.0 V ±10%	0.5T - 9			ns
		V _{DD} = 3.0 V ±10%	0.5T - 9			ns
		V _{DD} = 2.0 V ±10%	0.5T - 20			ns
Data setup time (to $\overline{WR}\uparrow$)	tSODWR	V _{DD} = 5.0 V ±10%	(1.5 + n)T - 20			ns
		V _{DD} = 3.0 V ±10%	(1.5 + n)T - 25			ns
		V _{DD} = 2.0 V ±10%	(1.5 + n)T - 70			ns
Data hold time (from $\overline{WR}\uparrow$)	tHWOD	V _{DD} = 5.0 V ±10%	0.5T - 14			ns
		V _{DD} = 3.0 V ±10%	0.5T - 14			ns
		V _{DD} = 2.0 V ±10%	0.5T - 50			ns
Delay time from $\overline{WR}\uparrow$ to ASTB \uparrow	tDWST	V _{DD} = 5.0 V ±10%	0.5T - 9			ns
		V _{DD} = 3.0 V ±10%	0.5T - 9			ns
		V _{DD} = 2.0 V ±10%	0.5T - 30			ns
\overline{WR} low-level width	tWWL	V _{DD} = 5.0 V ±10%	(1.5 + n)T - 25			ns
		V _{DD} = 3.0 V ±10%	(1.5 + n)T - 30			ns
		V _{DD} = 2.0 V ±10%	(1.5 + n)T - 30			ns

Remark T: t_{cyk} = 1/f_{xx} (f_{xx}: main system clock frequency)

a: 1 (during address wait), otherwise, 0

n: Number of wait states (n ≥ 0)

AC Characteristics

(2) External wait timing

Parameter	Symbol	Conditions	MIN.	TYP.	MAX.	Unit
Input time from address to $\overline{\text{WAIT}}\downarrow$	t_{DAWT}	$V_{\text{DD}} = 5.0 \text{ V} \pm 10\%$			$(2 + a)T - 40$	ns
		$V_{\text{DD}} = 3.0 \text{ V} \pm 10\%$			$(2 + a)T - 60$	ns
		$V_{\text{DD}} = 2.0 \text{ V} \pm 10\%$			$(2 + a)T - 300$	ns
Input time from $\text{ASTB}\downarrow$ to $\overline{\text{WAIT}}\downarrow$	t_{DSTWT}	$V_{\text{DD}} = 5.0 \text{ V} \pm 10\%$			$1.5T - 40$	ns
		$V_{\text{DD}} = 3.0 \text{ V} \pm 10\%$			$1.5T - 60$	ns
		$V_{\text{DD}} = 2.0 \text{ V} \pm 10\%$			$1.5T - 260$	ns
Hold time from $\text{ASTB}\downarrow$ to $\overline{\text{WAIT}}$	t_{HSTWT}	$V_{\text{DD}} = 5.0 \text{ V} \pm 10\%$	$(0.5 + n)T + 5$			ns
		$V_{\text{DD}} = 3.0 \text{ V} \pm 10\%$	$(0.5 + n)T + 10$			ns
		$V_{\text{DD}} = 2.0 \text{ V} \pm 10\%$	$(0.5 + n)T + 30$			ns
Delay time from $\text{ASTB}\downarrow$ to $\overline{\text{WAIT}}\uparrow$	t_{DSTWTH}	$V_{\text{DD}} = 5.0 \text{ V} \pm 10\%$			$(1.5 + n)T - 40$	ns
		$V_{\text{DD}} = 3.0 \text{ V} \pm 10\%$			$(1.5 + n)T - 60$	ns
		$V_{\text{DD}} = 2.0 \text{ V} \pm 10\%$			$(1.5 + n)T - 90$	ns
Input time from $\overline{\text{RD}}\downarrow$ to $\overline{\text{WAIT}}\downarrow$	t_{DRWTL}	$V_{\text{DD}} = 5.0 \text{ V} \pm 10\%$			$T - 40$	ns
		$V_{\text{DD}} = 3.0 \text{ V} \pm 10\%$			$T - 60$	ns
		$V_{\text{DD}} = 2.0 \text{ V} \pm 10\%$			$T - 70$	ns
Hold time from $\overline{\text{RD}}\downarrow$ to $\overline{\text{WAIT}}\downarrow$	t_{HRWT}	$V_{\text{DD}} = 5.0 \text{ V} \pm 10\%$	$nT + 5$			ns
		$V_{\text{DD}} = 3.0 \text{ V} \pm 10\%$	$nT + 10$			ns
		$V_{\text{DD}} = 2.0 \text{ V} \pm 10\%$	$nT + 30$			ns
Delay time from $\overline{\text{RD}}\downarrow$ to $\overline{\text{WAIT}}\uparrow$	t_{DRWTH}	$V_{\text{DD}} = 5.0 \text{ V} \pm 10\%$			$(1 + n)T - 40$	ns
		$V_{\text{DD}} = 3.0 \text{ V} \pm 10\%$			$(1 + n)T - 60$	ns
		$V_{\text{DD}} = 2.0 \text{ V} \pm 10\%$			$(1 + n)T - 90$	ns
Data input time from $\overline{\text{WAIT}}\uparrow$	t_{DWTID}	$V_{\text{DD}} = 5.0 \text{ V} \pm 10\%$			$0.5T - 5$	ns
		$V_{\text{DD}} = 3.0 \text{ V} \pm 10\%$			$0.5T - 10$	ns
		$V_{\text{DD}} = 2.0 \text{ V} \pm 10\%$			$0.5T - 30$	ns
Delay time from $\overline{\text{WAIT}}\uparrow$ to $\overline{\text{RD}}\uparrow$	t_{DWTR}	$V_{\text{DD}} = 5.0 \text{ V} \pm 10\%$	$0.5T$			ns
		$V_{\text{DD}} = 3.0 \text{ V} \pm 10\%$	$0.5T$			ns
		$V_{\text{DD}} = 2.0 \text{ V} \pm 10\%$	$0.5T + 5$			ns
Delay time from $\overline{\text{WAIT}}\uparrow$ to $\overline{\text{WR}}\uparrow$	t_{DWTW}	$V_{\text{DD}} = 5.0 \text{ V} \pm 10\%$	$0.5T$			ns
		$V_{\text{DD}} = 3.0 \text{ V} \pm 10\%$	$0.5T$			ns
		$V_{\text{DD}} = 2.0 \text{ V} \pm 10\%$	$0.5T + 5$			ns
Input time from $\overline{\text{WR}}\downarrow$ to $\overline{\text{WAIT}}\downarrow$	t_{DWWTL}	$V_{\text{DD}} = 5.0 \text{ V} \pm 10\%$			$T - 40$	ns
		$V_{\text{DD}} = 3.0 \text{ V} \pm 10\%$			$T - 60$	ns
		$V_{\text{DD}} = 2.0 \text{ V} \pm 10\%$			$T - 90$	ns
Hold time from $\overline{\text{WR}}\downarrow$ to $\overline{\text{WAIT}}$	t_{HWWT}	$V_{\text{DD}} = 5.0 \text{ V} \pm 10\%$	$nT + 5$			ns
		$V_{\text{DD}} = 3.0 \text{ V} \pm 10\%$	$nT + 10$			ns
		$V_{\text{DD}} = 2.0 \text{ V} \pm 10\%$	$nT + 30$			ns
Delay time from $\overline{\text{WR}}\downarrow$ to $\overline{\text{WAIT}}\uparrow$	t_{DWWTH}	$V_{\text{DD}} = 5.0 \text{ V} \pm 10\%$			$(1 + n)T - 40$	ns
		$V_{\text{DD}} = 3.0 \text{ V} \pm 10\%$			$(1 + n)T - 60$	ns
		$V_{\text{DD}} = 2.0 \text{ V} \pm 10\%$			$(1 + n)T - 90$	ns

Remark T: $t_{\text{CYK}} = 1/f_{\text{xx}}$ (f_{xx} : main system clock frequency)

a: 1 (during address wait), otherwise, 0

n: Number of wait states ($n \geq 0$)

Serial Operation (T_A = -40 to +85°C, V_{DD} = AV_{DD} = 1.8 to 5.5 V, V_{SS} = AV_{SS} = 0 V)

(a) 3-wire serial I/O mode ($\overline{\text{SCK}}$: Internal clock output)

Parameter	Symbol	Conditions	MIN.	TYP.	MAX.	Unit
$\overline{\text{SCK}}$ cycle time	t _{KCY1}	2.7 V ≤ V _{DD} ≤ 5.5 V	800			ns
			3,200			ns
$\overline{\text{SCK}}$ high-/low-level width	t _{KH1} , t _{KL1}	2.7 V ≤ V _{DD} ≤ 5.5 V	350			ns
			1,500			ns
SI setup time (to $\overline{\text{SCK}}\uparrow$)	t _{SIK1}	2.7 V ≤ V _{DD} ≤ 5.5 V	10			ns
			30			ns
SI hold time (from $\overline{\text{SCK}}\uparrow$)	t _{KSI1}		40			ns
SO output delay time (from $\overline{\text{SCK}}\downarrow$)	t _{KSO1}				30	ns

(b) 3-wire serial I/O mode ($\overline{\text{SCK}}$: External clock input)

Parameter	Symbol	Conditions	MIN.	TYP.	MAX.	Unit
$\overline{\text{SCK}}$ cycle time	t _{KCY2}	2.7 V ≤ V _{DD} ≤ 5.5 V	800			ns
			3,200			ns
$\overline{\text{SCK}}$ high-/low-level width	t _{KH2} , t _{KL2}	2.7 V ≤ V _{DD} ≤ 5.5 V	400			ns
			1,600			ns
SI setup time (to $\overline{\text{SCK}}\uparrow$)	t _{SIK2}	2.7 V ≤ V _{DD} ≤ 5.5 V	10			ns
			30			ns
SI hold time (from $\overline{\text{SCK}}\uparrow$)	t _{KSI2}		40			ns
SO output delay time (from $\overline{\text{SCK}}\downarrow$)	t _{KSO2}				30	ns

(c) UART mode

Parameter	Symbol	Conditions	MIN.	TYP.	MAX.	Unit
ASCK cycle time	t _{KCY3}	4.5 V ≤ V _{DD} ≤ 5.5 V	417			ns
		2.7 V ≤ V _{DD} < 4.5 V	833			ns
			1,667			ns
ASCK high-/low-level width	t _{KH3} , t _{KL3}	4.5 V ≤ V _{DD} ≤ 5.5 V	208			ns
		2.7 V ≤ V _{DD} < 4.5 V	416			ns
			833			ns

(d) I²C bus mode

Parameter	Symbol	Standard Mode		High-Speed Mode		Unit
		MIN.	MAX.	MIN.	MAX.	
SCL0 clock frequency	f _{CLK}	0	100	0	400	kHz
Bus free time (between stop and start conditions)	t _{BUF}	4.7	–	1.3	–	μs
Hold time ^{Note 1}	t _{HD : STA}	4.0	–	0.6	–	μs
Low-level width of SCL0 clock	t _{LOW}	4.7	–	1.3	–	μs
High-level width of SCL0 clock	t _{HIGH}	4.0	–	0.6	–	μs
Setup time of start/restart conditions	t _{SU : STA}	4.7	–	0.6	–	μs
Data hold time	When using CBUS-compatible master	t _{HD : DAT}	5.0	–	–	μs
	When using I ² C bus	t _{HD : DAT}	0 ^{Note 2}	–	0 ^{Note 2}	0.9 ^{Note 3}
Data setup time	t _{SU : DAT}	250	–	100 ^{Note 4}	–	ns
Rise time of SDA0 and SCL0 signals	t _R	–	1,000	20 + 0.1Cb ^{Note 5}	300	ns
Fall time of SDA0 and SCL0 signals	t _F	–	300	20 + 0.1Cb ^{Note 5}	300	ns
Setup time of stop condition	t _{SU : STO}	4.0	–	0.6	–	μs
Pulse width of spike restricted by input filter	t _{SP}	–	–	0	50	ns
Load capacitance of each bus line	C _b	–	400	–	400	pF

- Notes**
- For the start condition, the first clock pulse is generated after the hold time.
 - To fill the undefined area of the SCL0 falling edge, it is necessary for the device to provide an internal SDA0 signal (on V_{IHmin.}) with at least 300 ns of hold time.
 - If the device does not extend the SCL0 signal low-level hold time (t_{LOW}), only the maximum data hold time t_{HD : DAT} needs to be satisfied.
 - The high-speed mode I²C bus can be used in a standard mode I²C bus system. In this case, the conditions described below must be satisfied.
 - If the device does not extend the SCL0 signal low-level hold time
t_{SU : DAT} ≥ 250 ns
 - If the device extends the SCL0 signal low-level hold time
Be sure to transmit the data bit to the SDA0 line before the SCL0 line is released (t_{Rmax.} + t_{SU : DAT} = 1,000 + 250 = 1,250 ns by standard mode I²C bus specification)
 - C_b: Total capacitance per bus line (unit: pF)

Other Operations (T_A = -40 to +85°C, V_{DD} = AV_{DD} = 1.8 to 5.5 V, V_{SS} = AV_{SS} = 0 V)

Parameter	Symbol	Conditions	MIN.	TYP.	MAX.	Unit
NMI high-/low-level width	t _{WNIL} t _{WNIH}		10			μs
INTP input high-/low-level width	t _{WITL} t _{WITL}	INTP0 to INTP6	100			ns
RESET high-/low-level width	t _{WRSL} t _{WRSH}		10			μs

Clock Output Operation (T_A = -40 to +85°C, V_{DD} = AV_{DD} = 1.8 to 5.5 V, V_{SS} = AV_{SS} = 0 V)

Parameter	Symbol	Conditions	MIN.	TYP.	MAX.	Unit
PCL cycle time	t _{CYCL}	4.5 V ≤ V _{DD} ≤ 5.5 V, nT	80		31,250	ns
PCL high-/low-level width	t _{CLL} t _{CLH}	4.5 V ≤ V _{DD} ≤ 5.5 V, 0.5T – 10	30		15,615	ns
PCL rise/fall time	t _{CLR}	4.5 V ≤ V _{DD} ≤ 5.5 V			5	ns
	t _{CLF}	2.7 V ≤ V _{DD} < 4.5 V			10	ns
		1.8 V ≤ V _{DD} < 2.7 V			20	ns

Remark T: t_{CYK} = 1/f_{XX} (f_{XX}: Main system clock frequency)

n: Divided frequency ratio set by software in the CPU

- When using the main system clock: n = 1, 2, 4, 8, 16, 32, 64, 128
- When using the subsystem clock: n = 1

A/D Converter Characteristics (T_A = -40 to +85°C, V_{DD} = AV_{DD} = 1.8 to 5.5 V, V_{SS} = AV_{SS} = 0 V)

Parameter	Symbol	Conditions	MIN.	TYP.	MAX.	Unit
Resolution			8	8	8	bits
Overall error ^{Notes 1, 2}		2.7 V ≤ V _{DD} ≤ 5.5 V 2.2 V ≤ AV _{REF0} ≤ V _{DD}			±1.2	%FSR
		1.8 V ≤ V _{DD} < 2.7 V 1.8 V ≤ AV _{REF0} ≤ V _{DD}			±1.6	%FSR
Conversion time	t _{CONV}		14		144	μs
Sampling time	t _{SAMP}		24/f _{XX}			μs
Analog input voltage	V _{IAN}		AV _{SS}		AV _{REF0}	V
Reference voltage	AV _{REF0}		1.8		AV _{DD}	V
Resistance between AV _{REF0} and AV _{SS}	R _{AVREF0}	When not A/D converting		40		kΩ

- Notes**
1. Quantization error (±1/2 LSB) is not included.
 2. Overall error is indicated as a ratio to the full-scale value.

Remark f_{XX} : Main system clock frequency

★ **D/A Converter Characteristics (T_A = -40 to +85°C, V_{DD} = AV_{DD} = 1.8 to 5.5 V, V_{SS} = AV_{SS} = 0 V)**

Parameter	Symbol	Conditions	MIN.	TYP.	MAX.	Unit	
Resolution			8	8	8	Bits	
Overall error ^{Notes 1, 2}		R = 10 MΩ, 2.0 V ≤ AV _{REF1} ≤ V _{DD} , 2.0 V ≤ V _{DD} ≤ 5.5 V			±0.6	%FSR	
		R = 10 MΩ, 1.8 V ≤ AV _{REF1} ≤ V _{DD} , 1.8 V ≤ V _{DD} ≤ 2.0 V			±1.2	%FSR	
Settling time		Load conditions: C = 30 pF	4.5 V ≤ AV _{REF1} ≤ 5.5 V			10	μs
			2.7 V ≤ AV _{REF1} < 4.5 V			15	μs
			1.8 V ≤ AV _{REF1} < 2.7 V			20	μs
Output resistance	R _O	DACS0, 1 = 55H		8		kΩ	
Reference voltage	AV _{REF1}		1.8		V _{DD}	V	
AV _{REF1} current	AI _{REF1}	For only 1 channel			2.5	mA	

- Notes**
1. Quantization error (±1/2 LSB) is not included.
 2. Overall error is indicated as a ratio to the full-scale value.

Data Retention Characteristics (T_A = -40 to +85°C, V_{DD} = AV_{DD} = 1.8 to 5.5 V, V_{SS} = AV_{SS} = 0 V)

Parameter	Symbol	Conditions	MIN.	TYP.	MAX.	Unit
Data retention voltage	V _{DDDR}	STOP mode	1.8		5.5	V
Data retention current	I _{DDDR}	V _{DDDR} = 5.0 V ±10%		10	50	μA
		V _{DDDR} = 2.0 V ±10%		2	10	μA
V _{DD} rise time	t _{rVD}		200			μs
V _{DD} fall time	t _{fVD}		200			μs
V _{DD} hold time (from STOP mode setting)	t _{HVD}		0			ms
STOP release signal input time	t _{DREL}		0			ms
Oscillation stabilization wait time	t _{WAIT}	Crystal resonator	30			ms
		Ceramic resonator	5			ms
Low-level input voltage	V _{IL}	RESET, P00/INTP0 to P06/INTP6	0		0.1V _{DDDR}	V
High-level input voltage	V _{IH}		0.9V _{DDDR}		V _{DDDR}	V

AC Timing Test Points

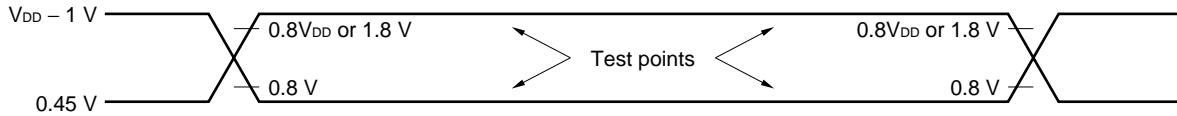

Timing Waveforms

★ (1) Read operations

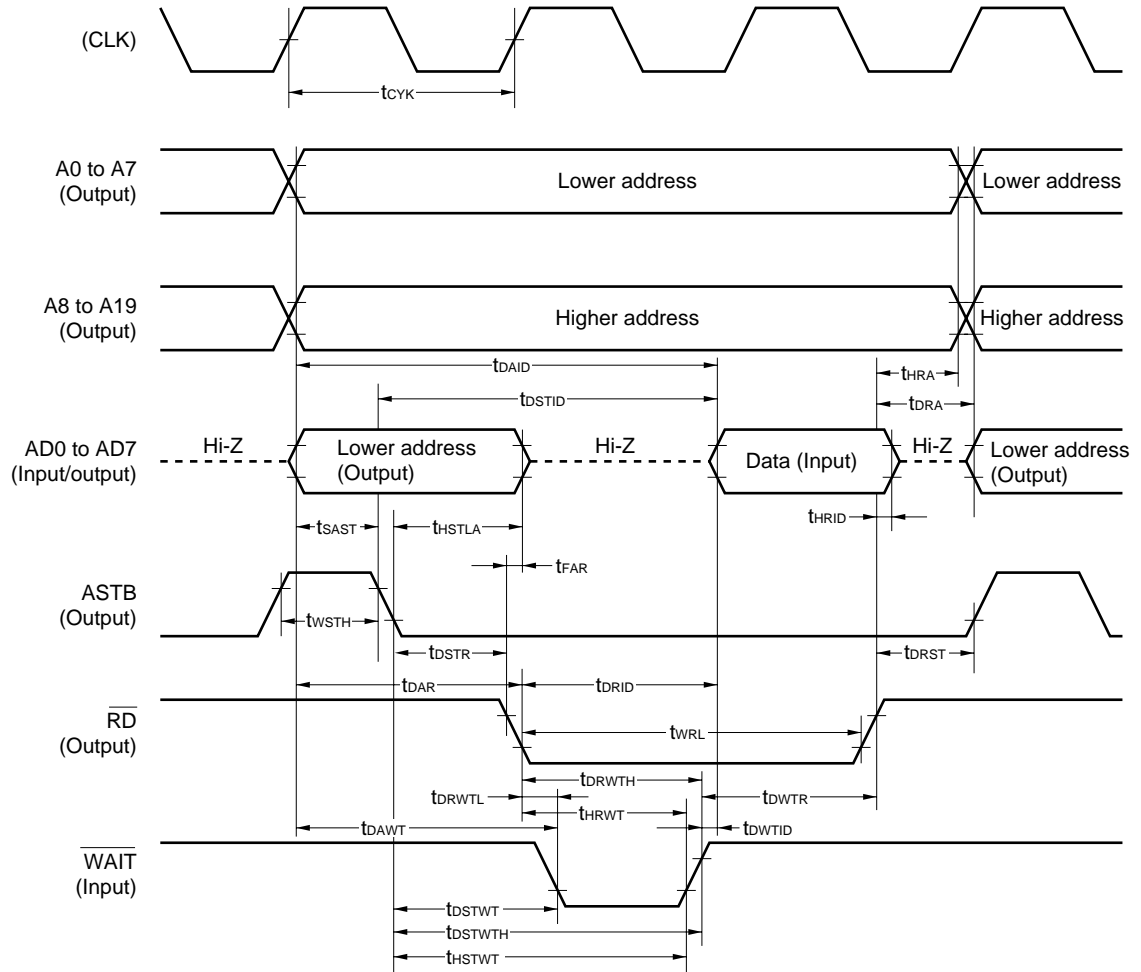

Remark The signal is output from pins A0 to A7 when P80 to P87 are unused.

★ (2) Write operation

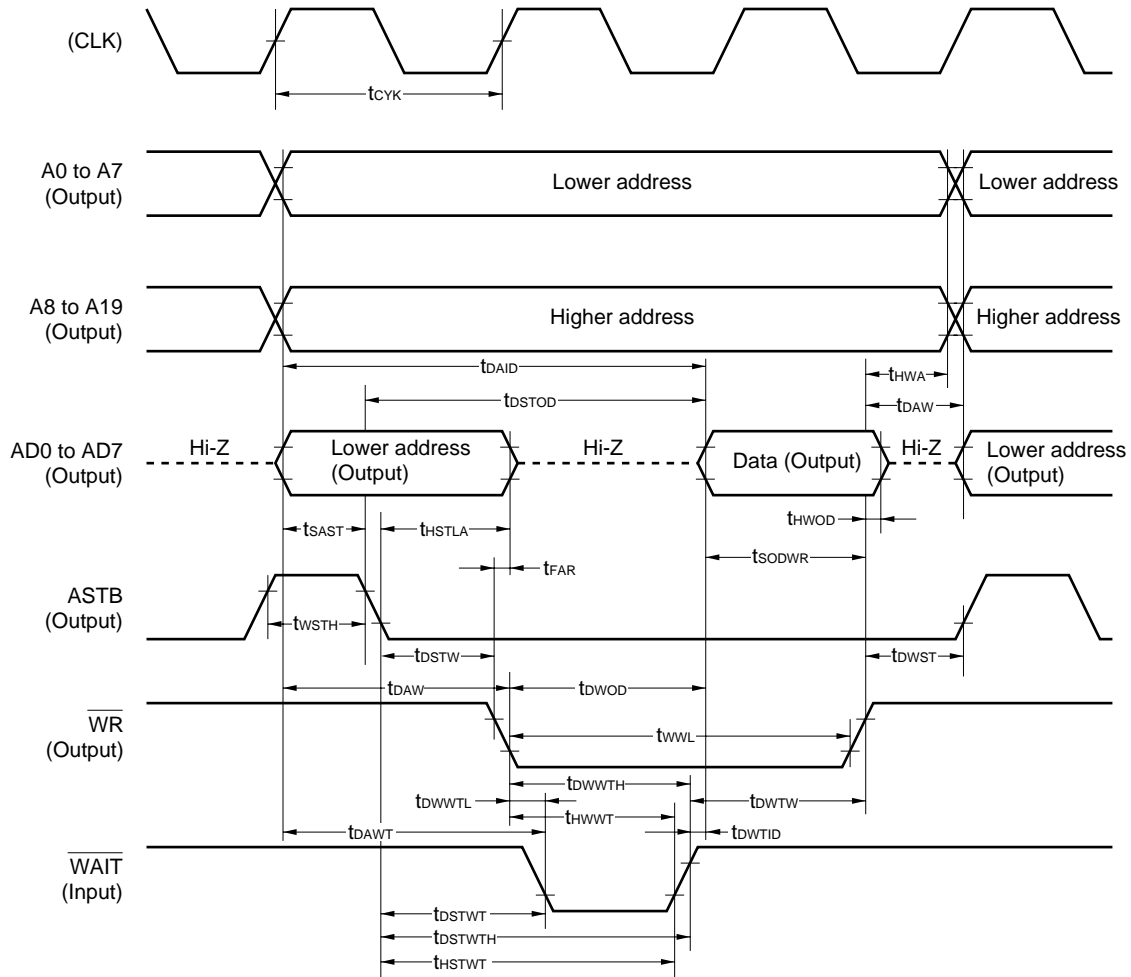

Remark The signal is output from pins A0 to A7 when P80 to P87 are unused.

Serial Operation

(1) 3-wire serial I/O mode

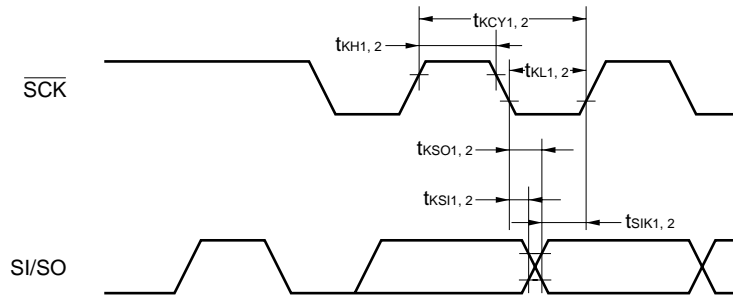

(2) UART mode

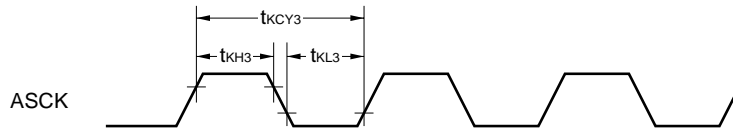

(3) I²C bus mode (μ PD784216AY/784218AY Subseries only)

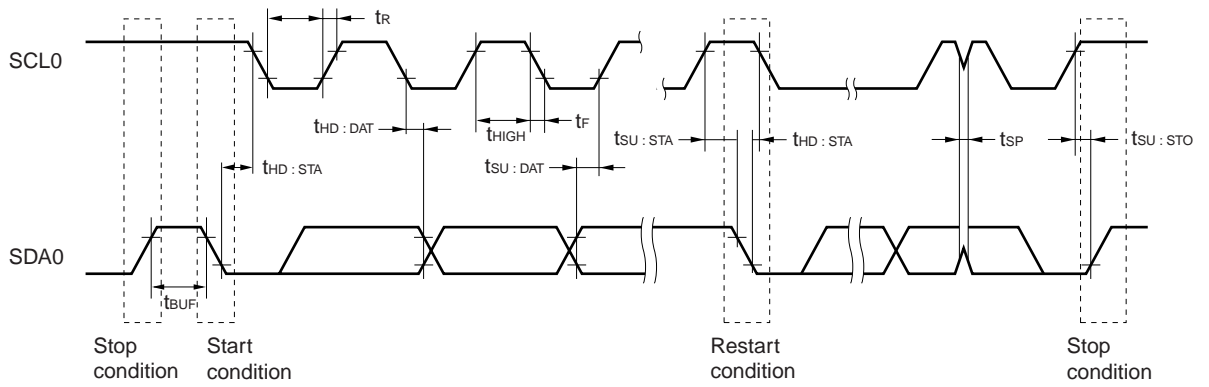

Clock Output Timing

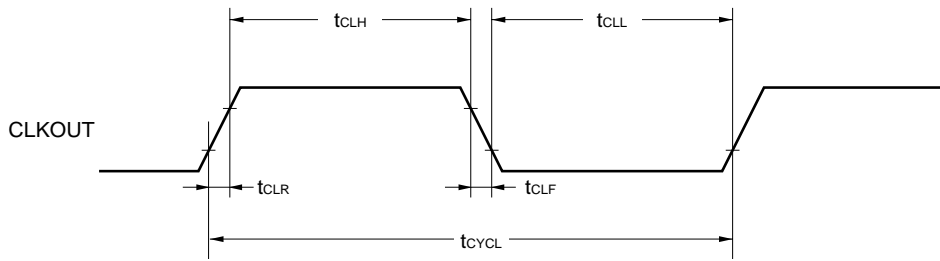

Interrupt Input Timing

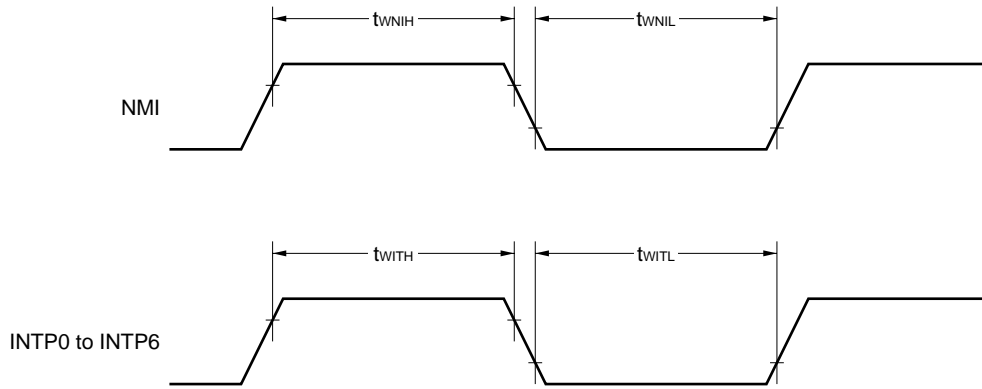

Reset Input Timing

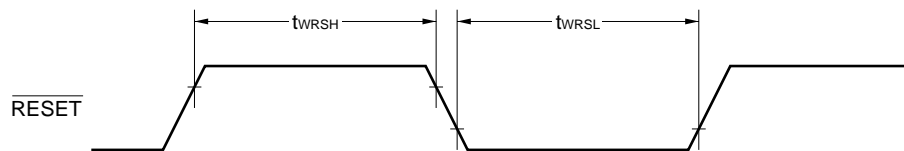

Clock Timing

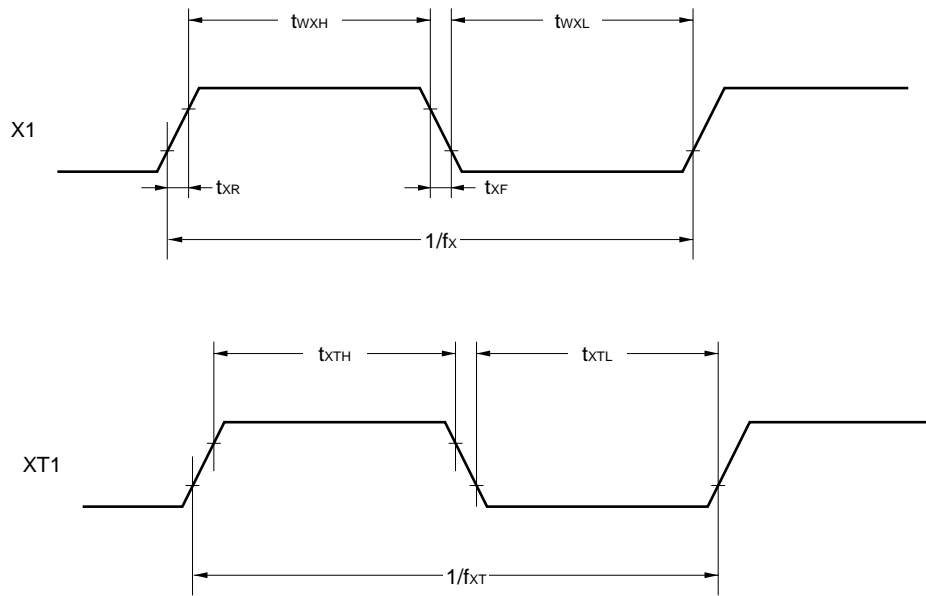

Data Retention Characteristics

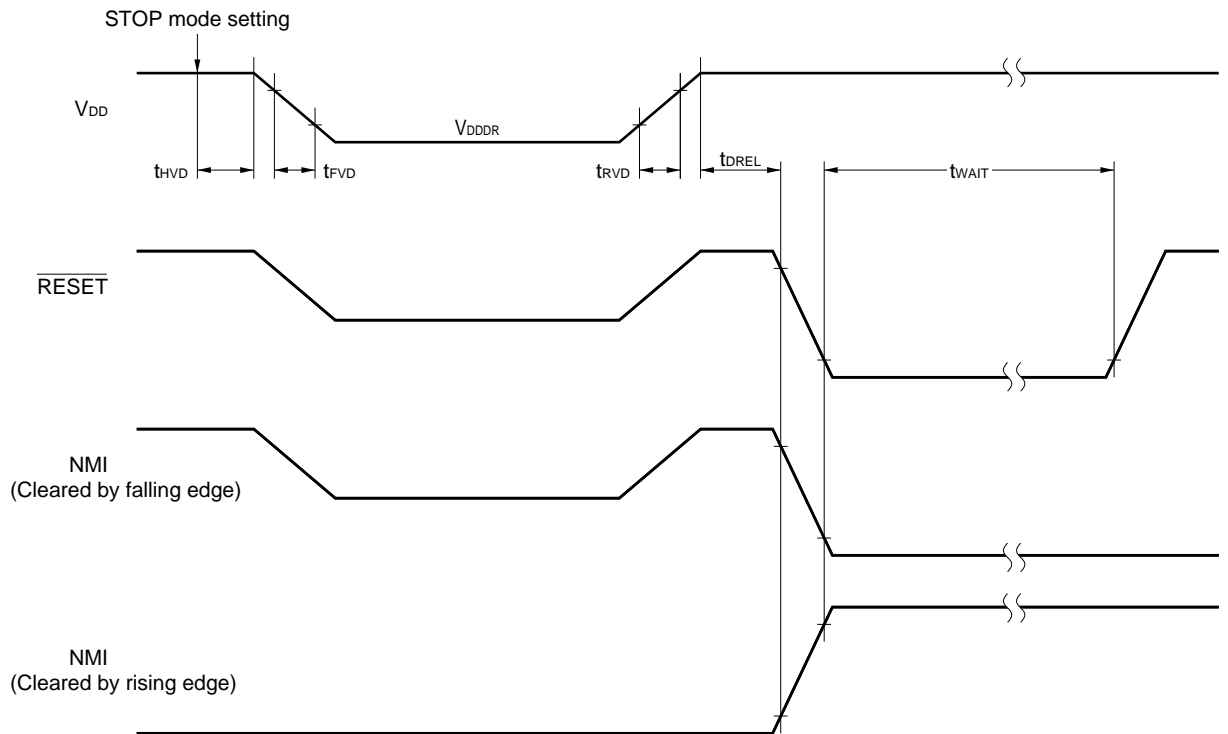

14. PACKAGE DRAWINGS

100-PIN PLASTIC LQFP (FINE PITCH) (14x14)

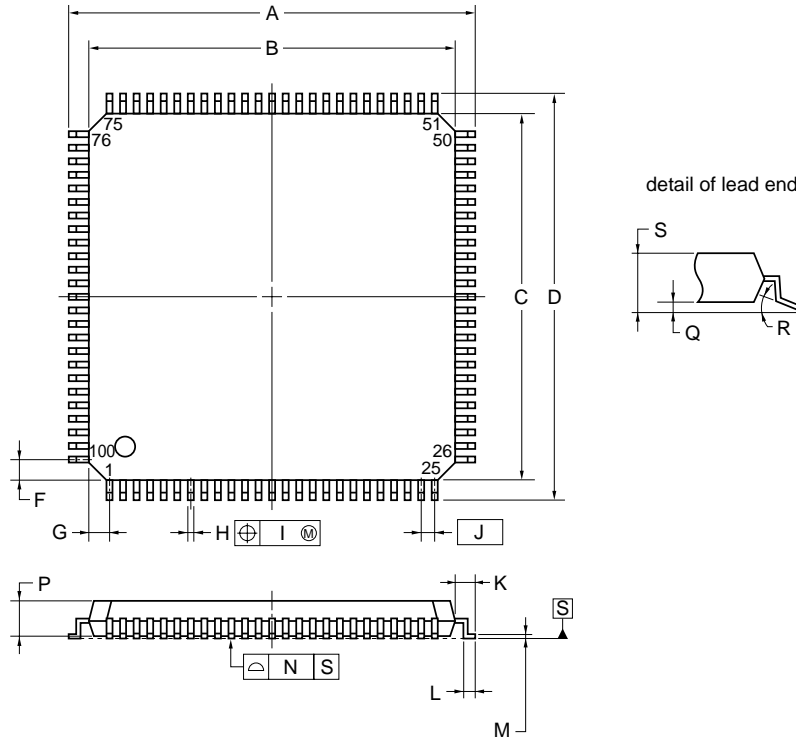

NOTE
 Each lead centerline is located within 0.08 mm of its true position (T.P.) at maximum material condition.

ITEM	MILLIMETERS
A	16.00±0.20
B	14.00±0.20
C	14.00±0.20
D	16.00±0.20
F	1.00
G	1.00
H	0.22 ^{+0.05} _{-0.04}
I	0.08
J	0.50 (T.P.)
K	1.00±0.20
L	0.50±0.20
M	0.17 ^{+0.03} _{-0.07}
N	0.08
P	1.40±0.05
Q	0.10±0.05
R	3 [°] ₋₃ [°] ₇
S	1.60 MAX.

S100GC-50-8EU, 8EA-2

Remark The external dimensions and material of the ES version are the same as those of the mass-produced version.

100-PIN PLASTIC QFP (14x20)

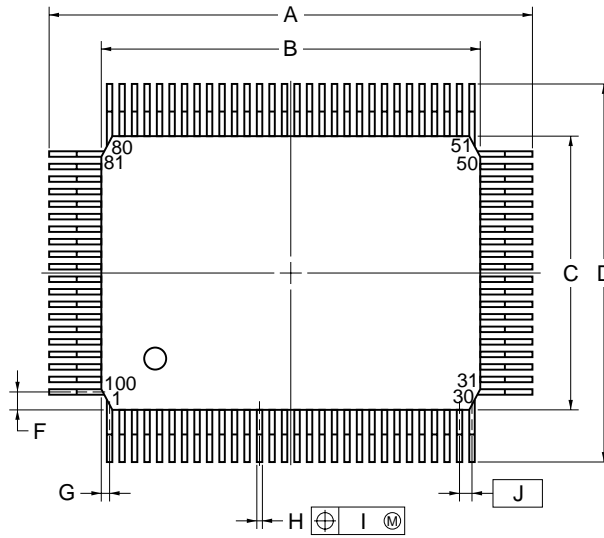

detail of lead end

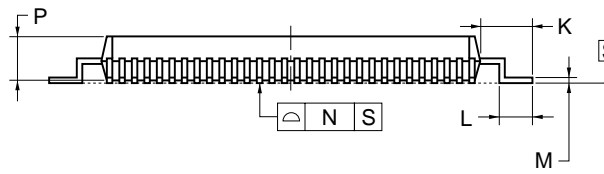
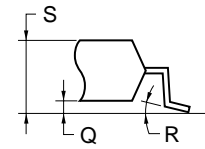

NOTE

Each lead centerline is located within 0.15 mm of its true position (T.P.) at maximum material condition.

ITEM	MILLIMETERS
A	23.6±0.4
B	20.0±0.2
C	14.0±0.2
D	17.6±0.4
F	0.8
G	0.6
H	0.30±0.10
I	0.15
J	0.65 (T.P.)
K	1.8±0.2
L	0.8±0.2
M	0.15 ^{+0.10} _{-0.05}
N	0.10
P	2.7±0.1
Q	0.1±0.1
R	5°±5°
S	3.0 MAX.

P100GF-65-3BA1-4

Remark The external dimensions and material of the ES version are the same as those of the mass-produced version.

★15. RECOMMENDED SOLDERING CONDITIONS

The μPD784218A should be soldered and mounted under the following recommended conditions. For the details of the recommended soldering conditions, refer to the document **Semiconductor Device Mounting Technology Manual (C10535E)**.

For soldering methods and conditions other than those recommended below, contact your NEC sales representative.

Table 15-1. Surface Mounting Type Soldering Conditions (1/2)

- (1) μPD784214AGC-xxx-8EU: 100-pin plastic LQFP (fine pitch) (14 × 14 mm)
- μPD784215AGC-xxx-8EU: 100-pin plastic LQFP (fine pitch) (14 × 14 mm)
- μPD784216AGC-xxx-8EU: 100-pin plastic LQFP (fine pitch) (14 × 14 mm)
- μPD784217AGC-xxx-8EU: 100-pin plastic LQFP (fine pitch) (14 × 14 mm)
- μPD784218AGC-xxx-8EU: 100-pin plastic LQFP (fine pitch) (14 × 14 mm)
- μPD784214AYGC-xxx-8EU: 100-pin plastic LQFP (fine pitch) (14 × 14 mm)
- μPD784215AYGC-xxx-8EU: 100-pin plastic LQFP (fine pitch) (14 × 14 mm)
- μPD784216AYGC-xxx-8EU: 100-pin plastic LQFP (fine pitch) (14 × 14 mm)
- μPD784217AYGC-xxx-8EU: 100-pin plastic LQFP (fine pitch) (14 × 14 mm)
- μPD784218AYGC-xxx-8EU: 100-pin plastic LQFP (fine pitch) (14 × 14 mm)

Soldering Method	Soldering Conditions	Recommended Condition Symbol
Infrared reflow	Package peak temperature: 235°C, Time: 30 seconds max. (at 210°C or higher), Count: Two times or less, Exposure limit: 7 days ^{Note} (after that, prebake at 125°C for 10 hours)	IR35-107-2
VPS	Package peak temperature: 215°C, Time: 40 seconds max. (at 200°C or higher), Count: Two times or less, Exposure limit: 7 days ^{Note} (after that, prebake at 125°C for 10 hours)	VP15-107-2
Partial heating	Pin temperature: 300°C max., Time: 3 seconds max. (per pin row)	—

Note After opening the dry pack, store it at 25°C or less and 65% RH or less for the allowable storage period.

Caution Do not use different soldering methods together (except for partial heating).

Table 15-1. Surface Mounting Type Soldering Conditions (2/2)

- (2) μPD784214AGF-xxx-3BA:100-pin plastic QFP(14 × 20 mm)
- μPD784215AGF-xxx-3BA:100-pin plastic QFP(14 × 20 mm)
- μPD784216AGF-xxx-3BA:100-pin plastic QFP(14 × 20 mm)
- μPD784217AGF-xxx-3BA: 100-pin plastic QFP (14 × 20 mm)
- μPD784218AGF-xxx-3BA: 100-pin plastic QFP (14 × 20 mm)
- μPD784214AYGF-xxx-3BA:100-pin plastic QFP(14 × 20 mm)
- μPD784215AYGF-xxx-3BA:100-pin plastic QFP(14 × 20 mm)
- μPD784216AYGF-xxx-3BA:100-pin plastic QFP(14 × 20 mm)
- μPD784217AYGF-xxx-3BA: 100-pin plastic QFP (14 × 20 mm)
- μPD784218AYGF-xxx-3BA: 100-pin plastic QFP (14 × 20 mm)

Soldering Method	Soldering Conditions	Recommended Condition Symbol
Infrared reflow	Package peak temperature: 235°C, Time: 30 seconds max. (at 210°C or higher), Count: Two times or less	IR35-00-2
VPS	Package peak temperature: 215°C, Time: 40 seconds max. (at 200°C or higher), Count: Two times or less	VP15-00-2
Wave soldering	Solder bath temperature: 260°C max., Time: 10 seconds max., Count: Once, Preheating temperature: 120°C max. (package surface temperature)	WS60-00-1
Partial heating	Pin temperature: 300°C max., Time: 3 seconds max. (per pin row)	—

Caution Do not use different soldering methods together (except for partial heating).

★ APPENDIX A. DEVELOPMENT TOOLS

The following development tools are available for system development using the μPD784218A. Also refer to (5) **Cautions on using development tools.**

(1) Language processing software

RA78K4	Assembler package common to 78K/IV Series
CC78K4	C compiler package common to 78K/IV Series
DF784218	Device file common to μPD784216A, 784216AY, 784218A, 784218AY Subseries
CC78K4-L	C compiler library source file common to 78K/IV Series

(2) Flash memory writing tools

Flashpro II (Model number: FL-PR2), Flashpro III (Model number: FL-PR3, PG-FP3)	Dedicated flash programmer for microcontroller incorporating flash memory
FA-100GF	Adapter for writing 100-pin plastic QFP (GF-3BA type) flash memory. Connection must be performed in accordance with the target product.
FA-100GC	Adapter for writing 100-pin plastic LQFP (GC-8EU type) flash memory. Connection must be performed in accordance with the target product.
Flashpro II controller, Flashpro III controller	Control program that runs on a personal computer and is attached to Flashpro II, Flashpro III. Operates on Windows™ 95, etc.

(3) Debugging tools

• When IE-78K4-NS in-circuit emulator is used

IE-78K4-NS	In-circuit emulator common to 78K/IV Series
IE-70000-MC-PS-B	Power supply unit for IE-78K4-NS
IE-70000-98-IF-C	Interface adapter required when PC-9800 series PC (except notebook type) is used as host machine (C bus supported)
IE-70000-CD-IF-A	PC card and cable when PC-9800 series notebook PC is used as host machine (PCMCIA socket supported)
IE-70000-PC-IF-C	Interface adapter required when using IBM PC/AT™ compatibles as host machine (ISA bus supported)
IE-70000-PCI-IF	Interface adapter required when using PC that incorporates PCI bus as host machine
IE-784225-NS-EM1	Emulation board to emulate μPD784216A, 784216AY, 784218A, 784218AY Subseries
NP-100GF	Emulation probe for 100-pin plastic QFP (GF-3BA type)
NP-100GC	Emulation probe for 100-pin plastic LQFP (GC-8EU type)
EV-9200GF-100	Socket to be mounted on a target system board made for 100-pin plastic QFP (GF-3BA type)
TGC-100SDW	Conversion adapter to connect the NP-100GC and a target system board on which a 100-pin plastic LQFP (GC-8EU type) can be mounted
ID78K4-NS	Integrated debugger for IE-78K4-NS
SM78K4	System simulator common to 78K/IV Series
DF784218	Device file common to μPD784216A, 784216AY, 784218A, 784218AY Subseries

• When IE-784000-R in-circuit emulator is used

IE-784000-R	In-circuit emulator common to 78K/IV Series
IE-70000-98-IF-C	Interface adapter required when PC-9800 series PC (except notebook type) is used as host machine (C bus supported)
IE-70000-PC-IF-C	Interface adapter required when using IBM PC/AT and compatibles as host machine (ISA bus supported)
IE-70000-PCI-IF	Interface adapter required when using PC that incorporates PCI bus as host machine
IE-78000-R-SV3	Interface adapter and cable required when EWS is used as host machine
IE-784225-NS-EM1	Emulation board to emulate μ PD784216A, 784216AY, 784218A, 784218AY Subseries
IE-784000-R-EM	Emulation board common to 78K/IV Series
IE-78K4-R-EX3	Emulation probe conversion board required when using IE-784225-NS-EM1 on IE-784000-R.
EP-784218GF-R	Emulation probe for 100-pin plastic QFP (GF-3BA type)
EP-78064GC-R	Emulation probe for 100-pin plastic LQFP (GC-8EU type)
EV-9200GF-100	Socket to be mounted on a target system board made for 100-pin plastic QFP (GF-3BA type)
TGC-100SDW	Conversion adapter to connect the EP-78064GC-R and a target system board on which a 100-pin plastic LQFP (GC-8EU type) can be mounted
ID78K4	Integrated debugger for IE-784000-R
SM78K4	System simulator common to 78K/IV Series
DF784218	Device file common to μ PD784216A, 784216AY, 784218A, 784218AY Subseries

(4) Real-time OS

RX78K/IV	Real-time OS for 78K/IV Series
MX78K4	OS for 78K/IV Series

(5) Cautions on using development tools

- The ID78K4-NS, ID78K4, and SM78K4 are used in combination with the DF784218.
- The CC78K4 and RX78K/IV are used in combination with the RA78K4 and DF784218.
- The FL-PR2, FL-PR3, FA-100GF, FA-100GC, NP-100GF, and NP-100GC are products made by Naito Densai Machida Mfg. Co., Ltd. (TEL: +81-44-822-3813).
- The TGC-100SDW is a product made by TOKYO ELETECH CORPORATION.
For further information, contact Daimaru Kogyo, Ltd.
Tokyo Electronic Division (TEL: +81-3-3820-7112)
Osaka Electronic Division (TEL: +81-6-6244-6672)
- For third party development tools, see the Single-Chip Microcontroller Development Tool Selection Guide (U11069E).
- The host machine and OS suitable for each software are as follows:

Host Machine [OS] Software	PC	EWS
	PC-9800 series [Windows] IBM PC/AT and compatibles [Japanese/English Windows]	HP9000 Series 700™ [HP-UX™] SPARCstation™ [SunOS™, Solaris™] NEWS™ (RISC) [NEWS-OS™]
RA78K4	√ Note	√
CC78K4	√ Note	√
ID78K4-NS	√	–
ID78K4	√	√
SM78K4	√	–
RX78K/IV	√ Note	√
MX78K4	√ Note	√

Note DOS-based software

APPENDIX B. RELATED DOCUMENTS

Documents related to devices

Document Name	Document No.	
	English	Japanese
μPD784214A, 784215A, 784216A, 784217A, 784218A, 784214AY, 784215AY, 784216AY, 784217AY, 784218AY Data Sheet	This document	U14121J
μPD78F4216A, 78F4216AY, 78F4218A, 78F4218AY Data Sheet	To be prepared	To be prepared
μPD784216A, 784216AY Subseries User's Manual Hardware	U13570E	U13570J
μPD784218A, 784218AY Subseries User's Manual Hardware	U12970E	U12970J
78K/IV Series User's Manual Instructions	U10905E	U10905J
78K/IV Series Instruction Table	–	U10594J
78K/IV Series Instruction Set	–	U10595J
78K/IV Series Application Note Software Basics	–	U10095J

Documents related to development tools (user's manuals)

Document Name		Document No.	
		English	Japanese
RA78K4 Assembler Package	Language	U11162E	U11162J
	Operation	U11334E	U11334J
RA78K Structured Assembler Preprocessor		U11743E	U11743J
CC78K4 C Compiler	Language	U11571E	U11571J
	Operation	U11572E	U11572J
IE-78K4-NS		U13356E	U13356J
IE-784000-R		U12903E	U12903J
IE-784218-R-EM1		U12155E	U12155J
IE-784225-NS-EM1		U13742E	U13742J
EP-78064		EEU-1469	EEU-934
SM78K4 System Simulator Windows Based	Reference	U10093E	U10093J
SM78K Series System Simulator	External Part User Open Interface Specifications	U10092E	U10092J
ID78K4-NS Integrated Debugger PC Based	Reference	U12796E	U12796J
ID78K4 Integrated Debugger Windows Based	Reference	U10440E	U10440J
ID78K4 Integrated Debugger HP-UX, SunOS, NEWS-OS based	Reference	U11960E	U11960J

Caution The related documents listed above are subject to change without notice. Be sure to use the latest version of each document for designing.

Documents related to embedded software (user's manuals)

Document Name		Document No.	
		English	Japanese
78K/IV Series Real-Time OS	Fundamental	U10603E	U10603J
	Installation	U10604E	U10604J
	Debugger	–	U10364J
78K/IV Series OS MX78K4	Fundamental	–	U11779J

Other documents

Document Name		Document No.	
		English	Japanese
SEMICONDUCTOR SELECTION GUIDE Products & Packages (CD-ROM)		X13769X	
Semiconductor Device Mounting Technology Manual		C10535E	C10535J
Quality Grades on NEC Semiconductor Devices		C11531E	C11531J
NEC Semiconductor Device Reliability/Quality Control System		C10983E	C10983J
Guide to Prevent Damage for Semiconductor Devices by Electrostatic Discharge (ESD)		C11892E	C11892J
Guide to Microcomputer-Related Products by Third Party		–	U11416J

Caution The related documents listed above are subject to change without notice. Be sure to use the latest version of each document for designing.

NOTES FOR CMOS DEVICES**① PRECAUTION AGAINST ESD FOR SEMICONDUCTORS**

Note:

Strong electric field, when exposed to a MOS device, can cause destruction of the gate oxide and ultimately degrade the device operation. Steps must be taken to stop generation of static electricity as much as possible, and quickly dissipate it once, when it has occurred. Environmental control must be adequate. When it is dry, humidifier should be used. It is recommended to avoid using insulators that easily build static electricity. Semiconductor devices must be stored and transported in an anti-static container, static shielding bag or conductive material. All test and measurement tools including work bench and floor should be grounded. The operator should be grounded using wrist strap. Semiconductor devices must not be touched with bare hands. Similar precautions need to be taken for PW boards with semiconductor devices on it.

② HANDLING OF UNUSED INPUT PINS FOR CMOS

Note:

No connection for CMOS device inputs can be cause of malfunction. If no connection is provided to the input pins, it is possible that an internal input level may be generated due to noise, etc., hence causing malfunction. CMOS devices behave differently than Bipolar or NMOS devices. Input levels of CMOS devices must be fixed high or low by using a pull-up or pull-down circuitry. Each unused pin should be connected to V_{DD} or GND with a resistor, if it is considered to have a possibility of being an output pin. All handling related to the unused pins must be judged device by device and related specifications governing the devices.

③ STATUS BEFORE INITIALIZATION OF MOS DEVICES

Note:

Power-on does not necessarily define initial status of MOS device. Production process of MOS does not define the initial operation status of the device. Immediately after the power source is turned ON, the devices with reset function have not yet been initialized. Hence, power-on does not guarantee out-pin levels, I/O settings or contents of registers. Device is not initialized until the reset signal is received. Reset operation must be executed immediately after power-on for devices having reset function.

Regional Information

Some information contained in this document may vary from country to country. Before using any NEC product in your application, please contact the NEC office in your country to obtain a list of authorized representatives and distributors. They will verify:

- Device availability
- Ordering information
- Product release schedule
- Availability of related technical literature
- Development environment specifications (for example, specifications for third-party tools and components, host computers, power plugs, AC supply voltages, and so forth)
- Network requirements

In addition, trademarks, registered trademarks, export restrictions, and other legal issues may also vary from country to country.

NEC Electronics Inc. (U.S.)

Santa Clara, California
Tel: 408-588-6000
800-366-9782
Fax: 408-588-6130
800-729-9288

NEC Electronics (Germany) GmbH

Duesseldorf, Germany
Tel: 0211-65 03 02
Fax: 0211-65 03 490

NEC Electronics (UK) Ltd.

Milton Keynes, UK
Tel: 01908-691-133
Fax: 01908-670-290

NEC Electronics Italiana s.r.l.

Milano, Italy
Tel: 02-66 75 41
Fax: 02-66 75 42 99

NEC Electronics (Germany) GmbH

Benelux Office
Eindhoven, The Netherlands
Tel: 040-2445845
Fax: 040-2444580

NEC Electronics (France) S.A.

Velizy-Villacoublay, France
Tel: 01-30-67 58 00
Fax: 01-30-67 58 99

NEC Electronics (France) S.A.

Madrid Office
Madrid, Spain
Tel: 91-504-2787
Fax: 91-504-2860

NEC Electronics (Germany) GmbH

Scandinavia Office
Taeby, Sweden
Tel: 08-63 80 820
Fax: 08-63 80 388

NEC Electronics Hong Kong Ltd.

Hong Kong
Tel: 2886-9318
Fax: 2886-9022/9044

NEC Electronics Hong Kong Ltd.

Seoul Branch
Seoul, Korea
Tel: 02-528-0303
Fax: 02-528-4411

NEC Electronics Singapore Pte. Ltd.

United Square, Singapore
Tel: 65-253-8311
Fax: 65-250-3583

NEC Electronics Taiwan Ltd.

Taipei, Taiwan
Tel: 02-2719-2377
Fax: 02-2719-5951

NEC do Brasil S.A.

Electron Devices Division
Guarulhos-SP Brasil
Tel: 55-11-6462-6810
Fax: 55-11-6462-6829

IEBus is a trademark of NEC Corporation.

Windows is either a registered trademark or a trademark of Microsoft Corporation in the United States and/or other countries.

PC/AT is a trademark of International Business Machines Corporation.

HP9000 series 700 and HP-UX are trademarks of Hewlett-Packard Company.

SPARCstation is a trademark of SPARC International, Inc.

Solaris and SunOS are trademarks of Sun Microsystems, Inc.

NEWS and NEWS-OS are trademarks of Sony Corporation.

Purchase of NEC I²C components conveys a license under the Philips I²C Patent Rights to use these components in an I²C system, provided that the system conforms to the I²C Standard Specification as defined by Philips.

The related documents indicated in this publication may include preliminary versions. However, preliminary versions are not marked as such.

The export of this product from Japan is regulated by the Japanese government. To export this product may be prohibited without governmental license, the need for which must be judged by the customer. The export or re-export of this product from a country other than Japan may also be prohibited without a license from that country. Please call an NEC sales representative.

• The information in this document is current as of August, 2000. The information is subject to change without notice. For actual design-in, refer to the latest publications of NEC's data sheets or data books, etc., for the most up-to-date specifications of NEC semiconductor products. Not all products and/or types are available in every country. Please check with an NEC sales representative for availability and additional information.

- No part of this document may be copied or reproduced in any form or by any means without prior written consent of NEC. NEC assumes no responsibility for any errors that may appear in this document.
- NEC does not assume any liability for infringement of patents, copyrights or other intellectual property rights of third parties by or arising from the use of NEC semiconductor products listed in this document or any other liability arising from the use of such products. No license, express, implied or otherwise, is granted under any patents, copyrights or other intellectual property rights of NEC or others.
- Descriptions of circuits, software and other related information in this document are provided for illustrative purposes in semiconductor product operation and application examples. The incorporation of these circuits, software and information in the design of customer's equipment shall be done under the full responsibility of customer. NEC assumes no responsibility for any losses incurred by customers or third parties arising from the use of these circuits, software and information.
- While NEC endeavours to enhance the quality, reliability and safety of NEC semiconductor products, customers agree and acknowledge that the possibility of defects thereof cannot be eliminated entirely. To minimize risks of damage to property or injury (including death) to persons arising from defects in NEC semiconductor products, customers must incorporate sufficient safety measures in their design, such as redundancy, fire-containment, and anti-failure features.
- NEC semiconductor products are classified into the following three quality grades:
"Standard", "Special" and "Specific". The "Specific" quality grade applies only to semiconductor products developed based on a customer-designated "quality assurance program" for a specific application. The recommended applications of a semiconductor product depend on its quality grade, as indicated below. Customers must check the quality grade of each semiconductor product before using it in a particular application.

"Standard": Computers, office equipment, communications equipment, test and measurement equipment, audio and visual equipment, home electronic appliances, machine tools, personal electronic equipment and industrial robots

"Special": Transportation equipment (automobiles, trains, ships, etc.), traffic control systems, anti-disaster systems, anti-crime systems, safety equipment and medical equipment (not specifically designed for life support)

"Specific": Aircraft, aerospace equipment, submersible repeaters, nuclear reactor control systems, life support systems and medical equipment for life support, etc.

The quality grade of NEC semiconductor products is "Standard" unless otherwise expressly specified in NEC's data sheets or data books, etc. If customers wish to use NEC semiconductor products in applications not intended by NEC, they must contact an NEC sales representative in advance to determine NEC's willingness to support a given application.

(Note)

- (1) "NEC" as used in this statement means NEC Corporation and also includes its majority-owned subsidiaries.
- (2) "NEC semiconductor products" means any semiconductor product developed or manufactured by or for NEC (as defined above).