

3.5A/2.5A, 12V, 0.050/0.130 Ohm, Logic Level, Complementary LittleFET™ Power MOSFET

This complementary power MOSFET is manufactured using an advanced MegaFET process. This process, which uses feature sizes approaching those of LSI integrated circuits, gives optimum utilization of silicon, resulting in outstanding performance. It is designed for use in applications such as switching regulators, switching converters, motor drivers, relay drivers, and low voltage bus switches. This product achieves full rated conduction at a gate bias in the 3V to 5V range, thereby facilitating true on-off power control directly from logic level (5V) integrated circuits.

Formerly developmental type TA49092.

Ordering Information

PART NUMBER	PACKAGE	BRAND
RF1K49092	MS-012AA	RF1K49092

NOTE: When ordering, use the entire part number. For ordering in tape and reel, add the suffix 96 to the part number, i.e., RF1K4909296.

Features

- 3.5A, 12V (N-Channel)
2.5A, 12V (P-Channel)
- $r_{DS(ON)} = 0.050\Omega$ (N-Channel)
 $r_{DS(ON)} = 0.130\Omega$ (P-Channel)
- Temperature Compensating PSPICE® Model
- On-Resistance vs Gate Drive Voltage Curves
- Peak Current vs Pulse Width Curve
- UIS Rating Curve
- Related Literature
 - TB334 "Guidelines for Soldering Surface Mount Components to PC Boards"

Symbol

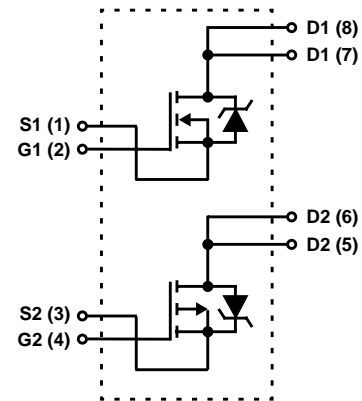

Packaging

JEDEC MS-012AA

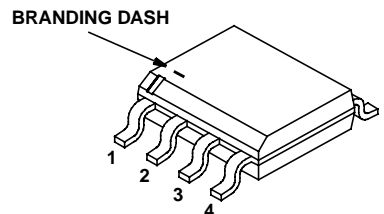

Absolute Maximum Ratings $T_A = 25^\circ\text{C}$ Unless Otherwise Specified

	N-CHANNEL	P-CHANNEL	UNITS	
Drain to Source Voltage (Note 1)	V_{DSS}	12	-12	V
Drain to Gate Voltage ($R_{GS} = 20k\Omega$, Note 1)	V_{DGR}	12	-12	V
Gate to Source Voltage	V_{GS}	± 10	± 10	V
Drain Current				
Continuous (Pulse Width = 5s)	I_D	3.5	2.5	A
Pulsed (Figures 5, 26)	I_{DM}	Refer to Peak Current Curve	Refer to Peak Current Curve	
Pulsed Avalanche Rating (Figures 6, 27)	E_{AS}	Refer to UIS Curve	Refer to UIS Curve	
Power Dissipation				
$T_A = 25^\circ\text{C}$	P_D	2	2	W
Derate Above 25°C		0.016	0.016	W/ $^\circ\text{C}$
Operating and Storage Temperature	T_J, T_{STG}	-55 to 150	-55 to 150	$^\circ\text{C}$
Maximum Temperature for Soldering				
Leads at 0.063in (1.6mm) from Case for 10s	T_L	300	300	$^\circ\text{C}$
Package Body for 10s, See Techbrief 334	T_{pkg}	260	260	$^\circ\text{C}$

CAUTION: Stresses above those listed in "Absolute Maximum Ratings" may cause permanent damage to the device. This is a stress only rating and operation of the device at these or any other conditions above those indicated in the operational sections of this specification is not implied.

NOTE:

1. $T_J = 25^\circ\text{C}$ to 125°C .

N-Channel Electrical Specifications $T_A = 25^\circ\text{C}$, Unless Otherwise Specified

PARAMETER	SYMBOL	TEST CONDITIONS	MIN	TYP	MAX	UNITS	
Drain to Source Breakdown Voltage	BV_{DSS}	$I_D = 250\mu\text{A}, V_{GS} = 0\text{V}$, (Figure 13)	12	-	-	V	
Gate Threshold Voltage	$V_{GS(TH)}$	$V_{GS} = V_{DS}, I_D = 250\mu\text{A}$, (Figure 12)	1	-	2	V	
Zero Gate Voltage Drain Current	I_{DSS}	$V_{DS} = 12\text{V}, V_{GS} = 0\text{V}$	$T_A = 25^\circ\text{C}$	-	-	1	μA
			$T_A = 150^\circ\text{C}$	-	-	50	μA
Gate to Source Leakage Current	I_{GSS}	$V_{GS} = \pm 10\text{V}$	-	-	± 100	nA	
Drain to Source On Resistance	$r_{DS(ON)}$	$I_D = 3.5\text{A}, V_{GS} = 5\text{V}$, (Figures 9, 11)	-	-	0.050	Ω	
Turn-On Time	t_{ON}	$V_{DD} = 6\text{V}, I_D \approx 3.5\text{A}, R_L = 1.71\Omega, V_{GS} = 5\text{V}, R_{GS} = 25\Omega$ (Figure 10)	-	-	100	ns	
Turn-On Delay Time	$t_{d(ON)}$		-	18	-	ns	
Rise Time	t_r		-	60	-	ns	
Turn-Off Delay Time	$t_{d(OFF)}$		-	50	-	ns	
Fall Time	t_f		-	60	-	ns	
Turn-Off Time	t_{OFF}		-	-	140	ns	
Total Gate Charge	$Q_{g(TOT)}$	$V_{GS} = 0\text{V to } 10\text{V}$	-	20	25	nC	
Gate Charge at 5V	$Q_{g(5)}$	$V_{GS} = 0\text{V to } 5\text{V}$					
Threshold Gate Charge	$Q_{g(TH)}$	$V_{GS} = 0\text{V to } 1\text{V}$					
Input Capacitance	C_{ISS}	$V_{DS} = 10\text{V}, V_{GS} = 0\text{V}, f = 1\text{MHz}$ (Figure 14)	-	750	-	pF	
Output Capacitance	C_{OSS}		-	700	-	pF	
Reverse Transfer Capacitance	C_{RSS}		-	275	-	pF	
Thermal Resistance Junction to Ambient	$R_{\theta JA}$	Pulse width = 1s Device mounted on FR-4 material	-	-	62.5	$^\circ\text{C/W}$	

N-Channel Source to Drain Diode Specifications

PARAMETER	SYMBOL	TEST CONDITIONS	MIN	TYP	MAX	UNITS
Source to Drain Voltage	V_{SD}	$I_{SD} = 3.5\text{A}$	-	-	1.25	V
Reverse Recovery Time	t_{rr}	$I_{SD} = 3.5\text{A}, dI_{SD}/dt = 100\text{A}/\mu\text{s}$	-	-	70	ns

P-Channel Electrical Specifications $T_A = 25^\circ\text{C}$, Unless Otherwise Specified

PARAMETER	SYMBOL	TEST CONDITIONS	MIN	TYP	MAX	UNITS	
Drain to Source Breakdown Voltage	BV_{DSS}	$I_D = 250\mu\text{A}$, $V_{GS} = 0\text{V}$, (Figure 34)	-12	-	-	V	
Gate Threshold Voltage	$V_{GS(TH)}$	$V_{GS} = V_{DS}$, $I_D = 250\mu\text{A}$, (Figure 33)	-1	-	-2	V	
Zero Gate Voltage Drain Current	I_{DSS}	$V_{DS} = -12\text{V}$, $V_{GS} = 0\text{V}$	$T_A = 25^\circ\text{C}$	-	-	-1	μA
			$T_A = 150^\circ\text{C}$	-	-	-50	μA
Gate to Source Leakage Current	I_{GSS}	$V_{GS} = \pm 10\text{V}$	-	-	± 100	nA	
Drain to Source On Resistance	$r_{DS(ON)}$	$I_D = 2.5\text{A}$, $V_{GS} = -5\text{V}$	-	-	0.130	Ω	
Turn-On Time	t_{ON}	$V_{DD} = -6\text{V}$, $I_D \approx 2.5\text{A}$, $R_L = 2.40\Omega$, $V_{GS} = -5\text{V}$, $R_{GS} = 25\Omega$ (Figure 31)	-	-	115	ns	
Turn-On Delay Time	$t_{d(ON)}$		-	25	-	ns	
Rise Time	t_r		-	65	-	ns	
Turn-Off Delay Time	$t_{d(OFF)}$		-	40	-	ns	
Fall Time	t_f		-	45	-	ns	
Turn-Off Time	t_{OFF}		-	-	110	ns	
Total Gate Charge	$Q_{g(TOT)}$		$V_{GS} = 0\text{V to } -10\text{V}$	$V_{DD} = -9.6\text{V}$, $I_D = 2.5\text{A}$, $R_L = 3.84\Omega$ (Figure 36)	-	19	24
Gate Charge at -5V	$Q_{g(-5)}$	$V_{GS} = 0\text{V to } -5\text{V}$	-		10	14	nC
Threshold Gate Charge	$Q_{g(TH)}$	$V_{GS} = 0\text{V to } -1\text{V}$	-		0.8	1.1	nC
Input Capacitance	C_{ISS}	$V_{DS} = -10\text{V}$, $V_{GS} = 0\text{V}$, $f = 1\text{MHz}$ (Figure 35)	-	775	-	pF	
Output Capacitance	C_{OSS}		-	550	-	pF	
Reverse Transfer Capacitance	C_{RSS}		-	150	-	pF	
Thermal Resistance Junction-to-Ambient	$R_{\theta JA}$		Pulse width = 1s Device mounted on FR-4 material	-	-	62.5	$^\circ\text{C/W}$

P-Channel Source to Drain Diode Specifications

PARAMETER	SYMBOL	TEST CONDITIONS	MIN	TYP	MAX	UNITS
Source to Drain Voltage	V_{SD}	$I_{SD} = -2.5\text{A}$	-	-	-1.25	V
Reverse Recovery Time	t_{rr}	$I_{SD} = -2.5\text{A}$, $dI_{SD}/dt = -100\text{A}/\mu\text{s}$	-	-	55	ns

Typical Performance Curves (N-Channel)

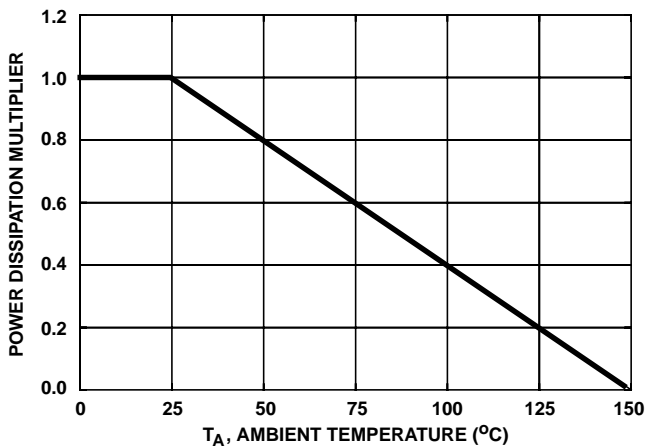

FIGURE 1. NORMALIZED POWER DISSIPATION vs AMBIENT TEMPERATURE

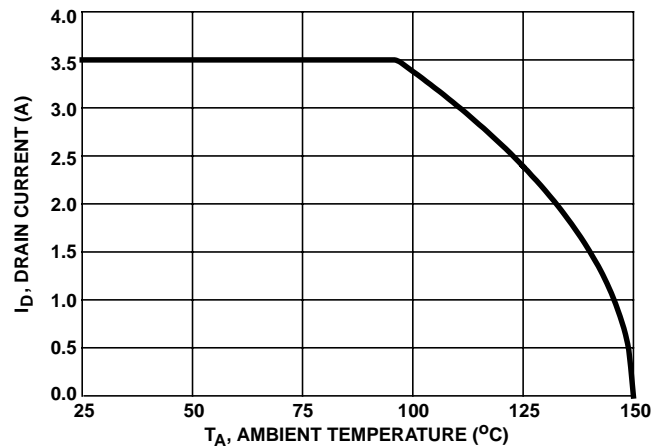

FIGURE 2. MAXIMUM CONTINUOUS DRAIN CURRENT vs AMBIENT TEMPERATURE

Typical Performance Curves (N-Channel) (Continued)

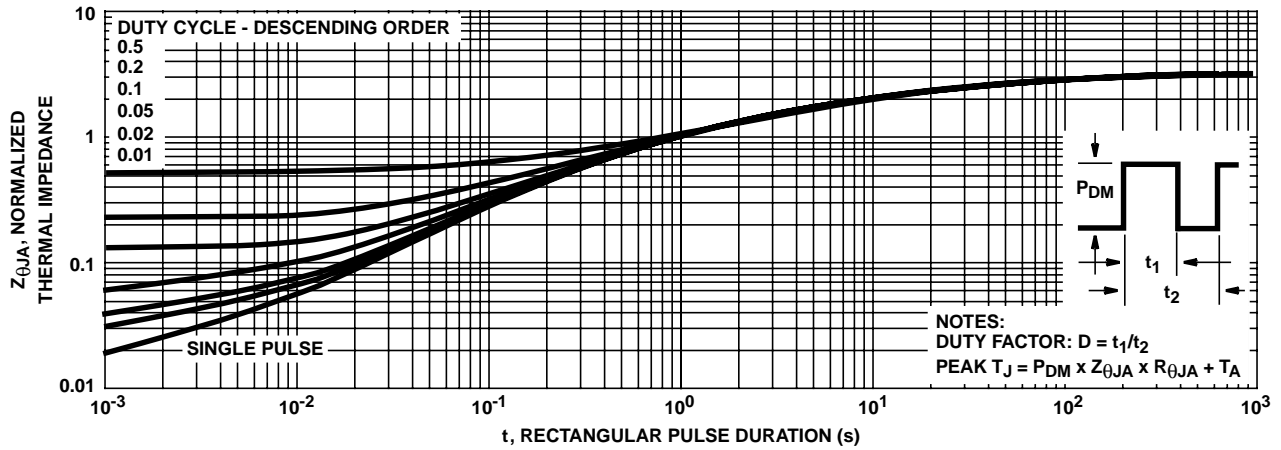

FIGURE 3. NORMALIZED MAXIMUM TRANSIENT THERMAL IMPEDANCE

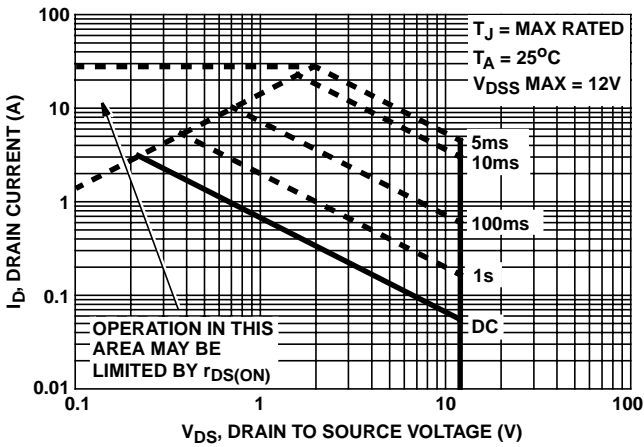

FIGURE 4. FORWARD BIAS SAFE OPERATING AREA

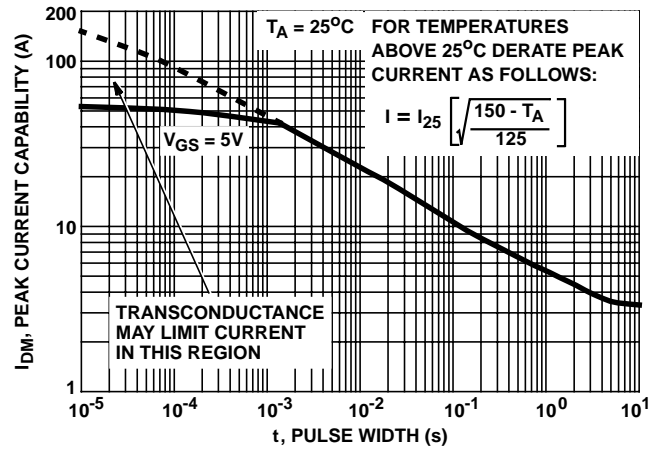
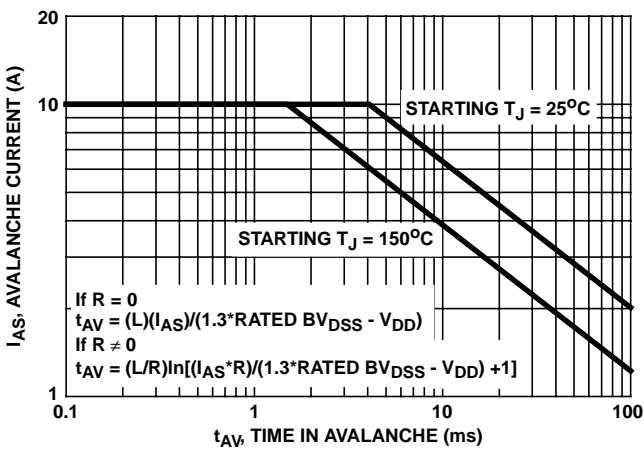

FIGURE 5. PEAK CURRENT CAPABILITY



NOTE: Refer to Intersil Application Notes AN9321 and AN9322.

FIGURE 6. UNCLAMPED INDUCTIVE SWITCHING CAPABILITY

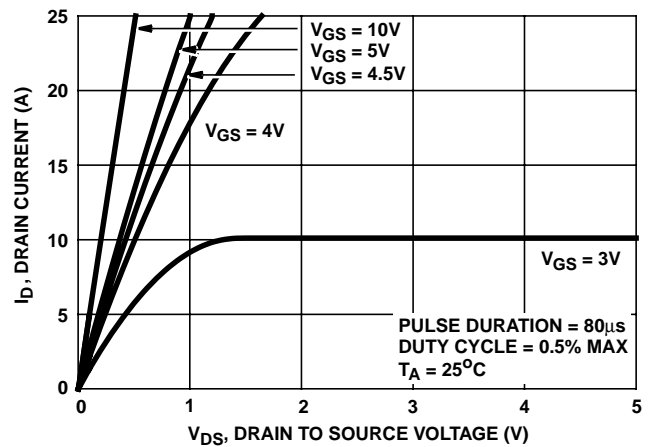

FIGURE 7. SATURATION CHARACTERISTICS

Typical Performance Curves (N-Channel) (Continued)

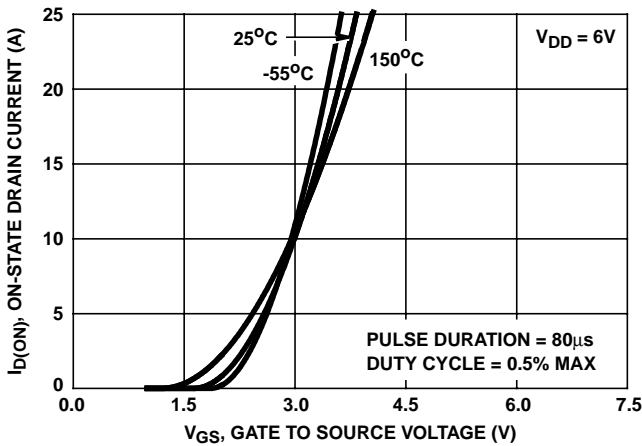

FIGURE 8. TRANSFER CHARACTERISTICS

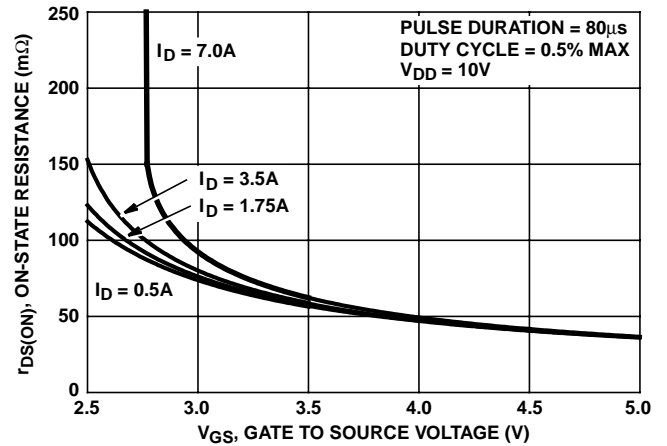

FIGURE 9. DRAIN TO SOURCE ON RESISTANCE vs GATE VOLTAGE AND DRAIN CURRENT

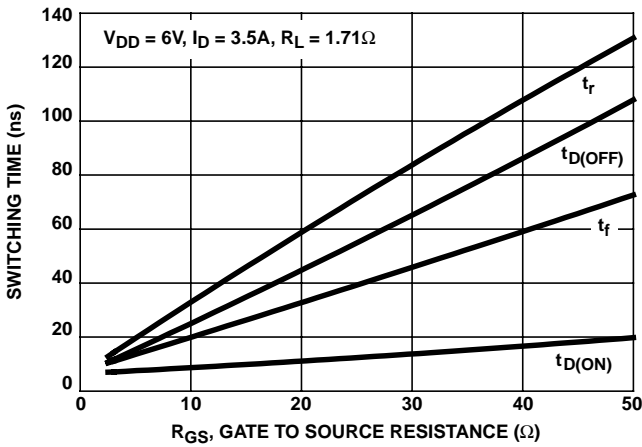

FIGURE 10. SWITCHING TIME vs GATE RESISTANCE

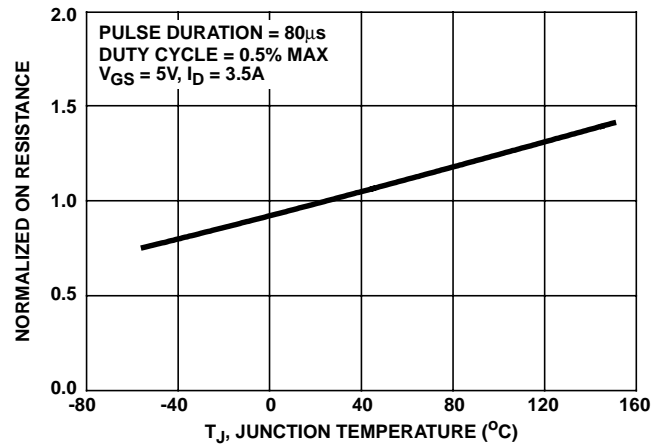

FIGURE 11. NORMALIZED DRAIN TO SOURCE ON RESISTANCE vs JUNCTION TEMPERATURE

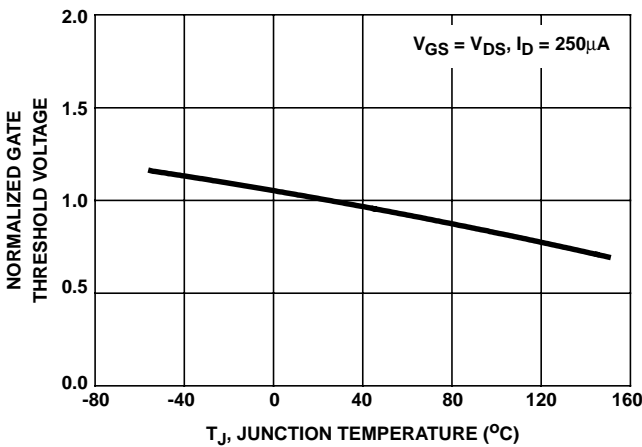

FIGURE 12. NORMALIZED GATE THRESHOLD VOLTAGE vs JUNCTION TEMPERATURE

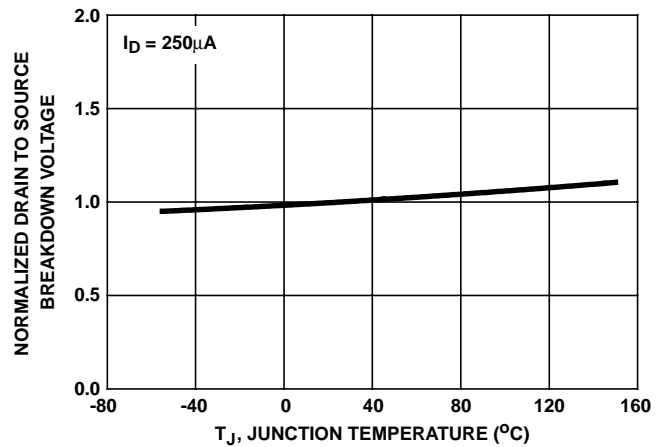

FIGURE 13. NORMALIZED DRAIN TO SOURCE BREAKDOWN VOLTAGE vs JUNCTION TEMPERATURE

Typical Performance Curves (N-Channel) (Continued)

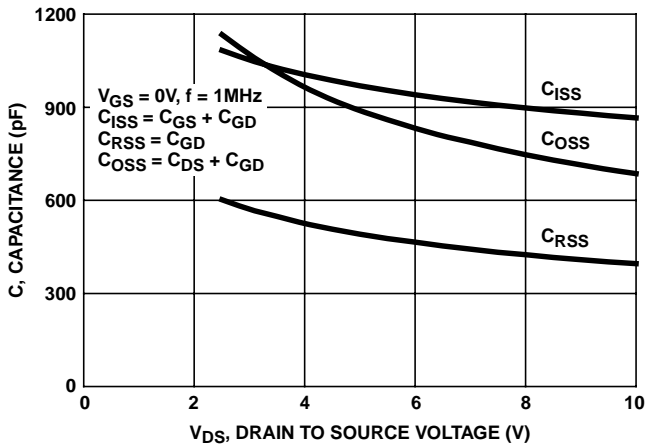
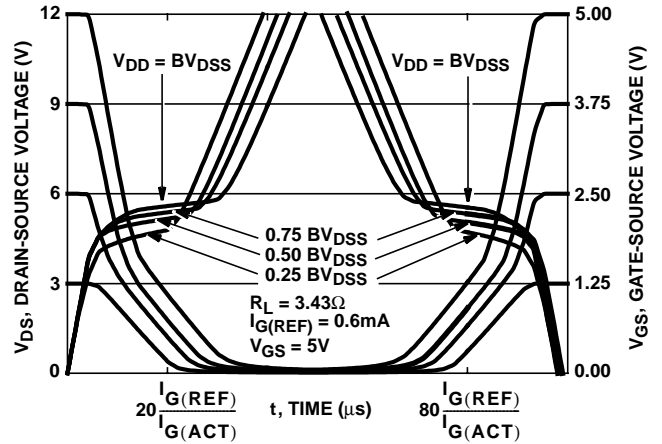

FIGURE 14. CAPACITANCE vs DRAIN TO SOURCE VOLTAGE



NOTE: Refer to Intersil Application Notes AN7254 and AN7260.

FIGURE 15. NORMALIZED SWITCHING WAVEFORMS FOR CONSTANT GATE CURRENT

Test Circuits and Waveforms (N-Channel)

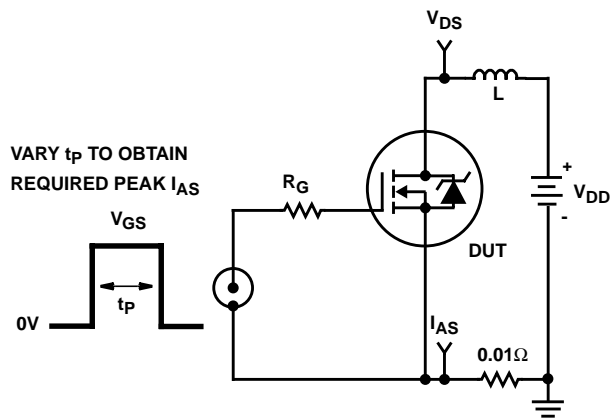

FIGURE 16. UNCLAMPED ENERGY TEST CIRCUIT

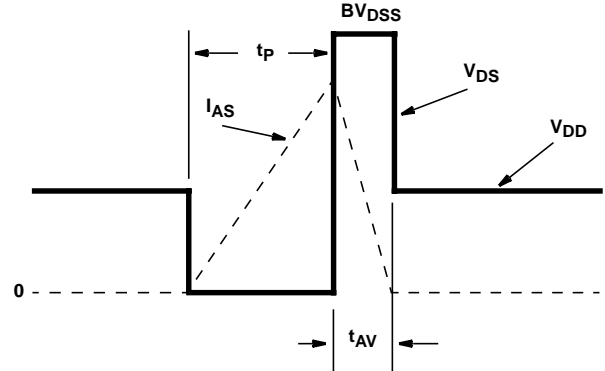

FIGURE 17. UNCLAMPED ENERGY WAVEFORMS

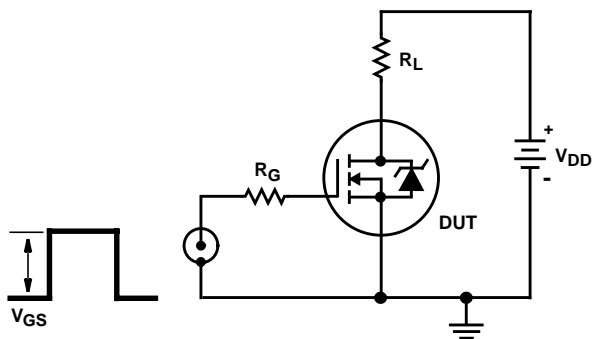

FIGURE 18. SWITCHING TIME TEST CIRCUIT

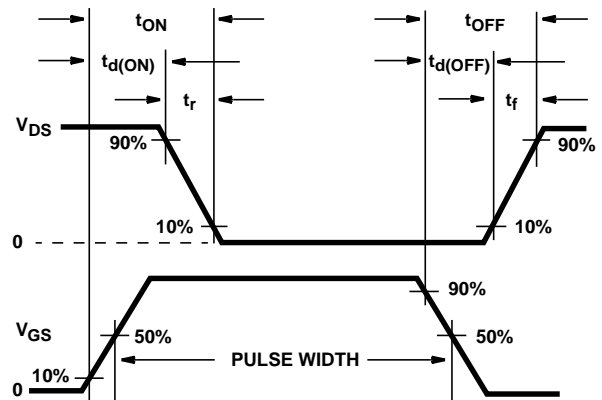

FIGURE 19. RESISTIVE SWITCHING WAVEFORMS

Test Circuits and Waveforms (N-Channel) (Continued)

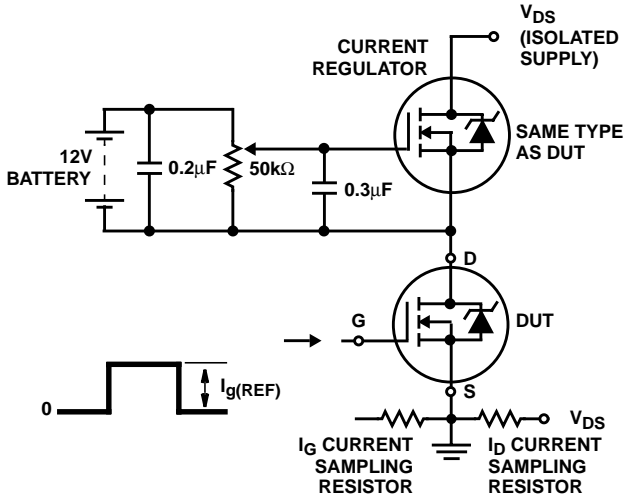

FIGURE 20. GATE CHARGE TEST CIRCUIT

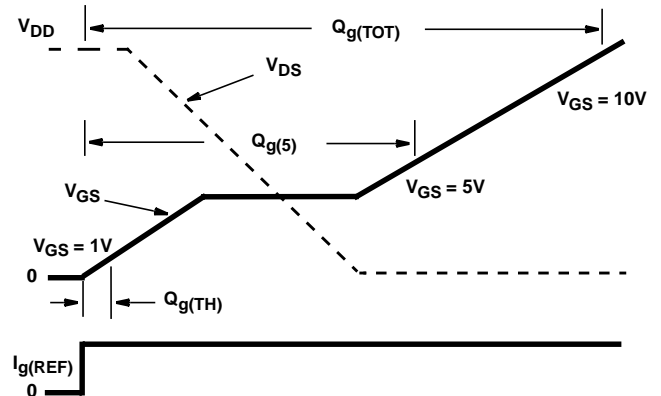

FIGURE 21. GATE CHARGE WAVEFORMS

Typical Performance Curves (P-Channel)

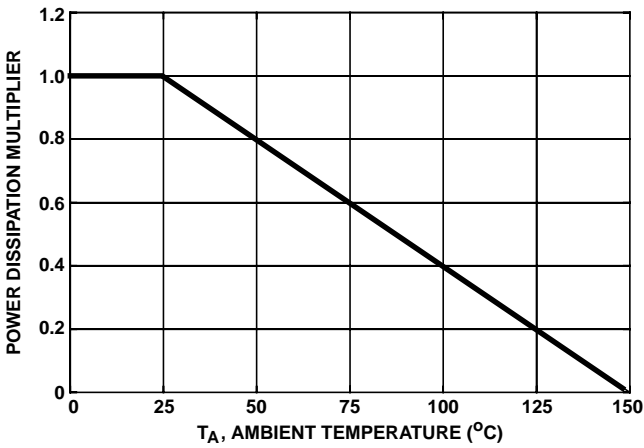

FIGURE 22. NORMALIZED POWER DISSIPATION vs AMBIENT TEMPERATURE

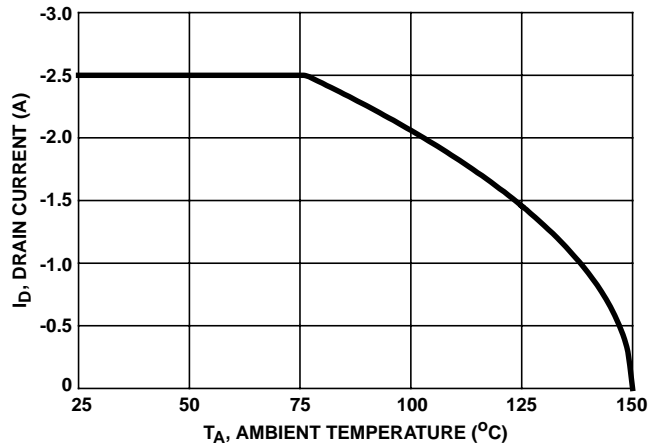

FIGURE 23. MAXIMUM CONTINUOUS DRAIN CURRENT vs AMBIENT TEMPERATURE

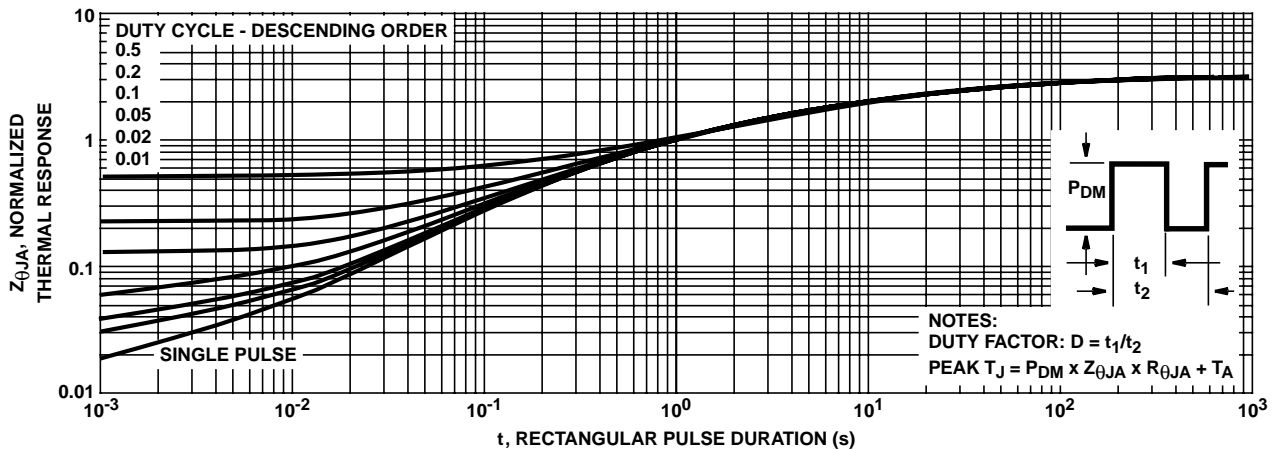

FIGURE 24. NORMALIZED MAXIMUM TRANSIENT THERMAL IMPEDANCE

Typical Performance Curves (P-Channel) (Continued)

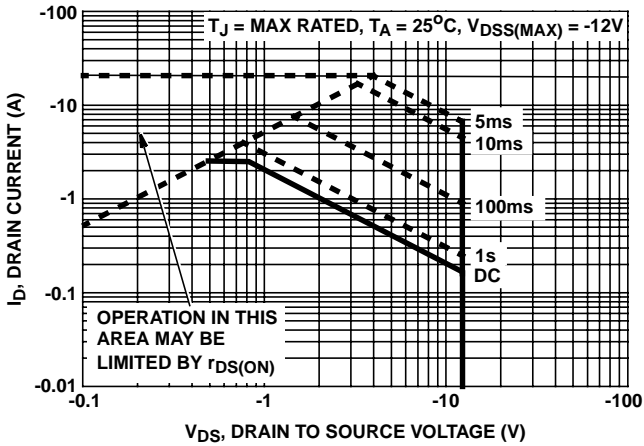

FIGURE 25. FORWARD BIAS SAFE OPERATING AREA

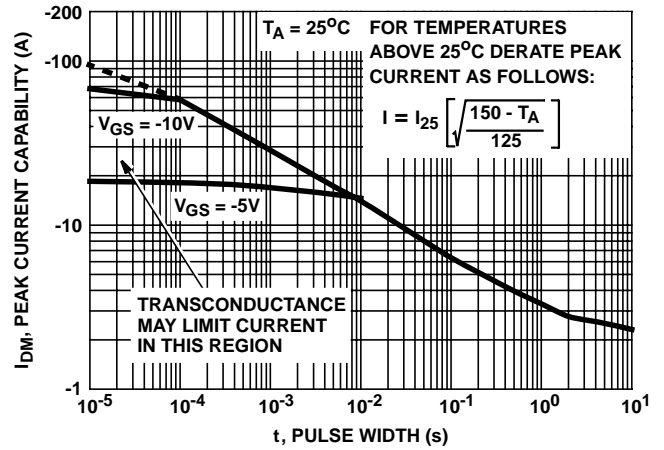
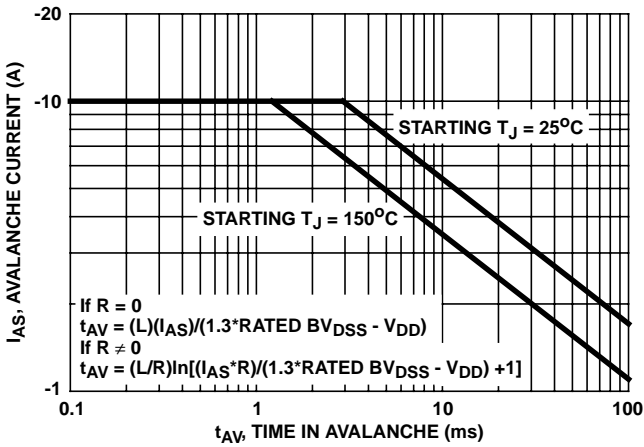

FIGURE 26. PEAK CURRENT CAPABILITY



NOTE: Refer to Intersil Application Notes AN9321 and AN9322.

FIGURE 27. UNCLAMPED INDUCTIVE SWITCHING CAPABILITY

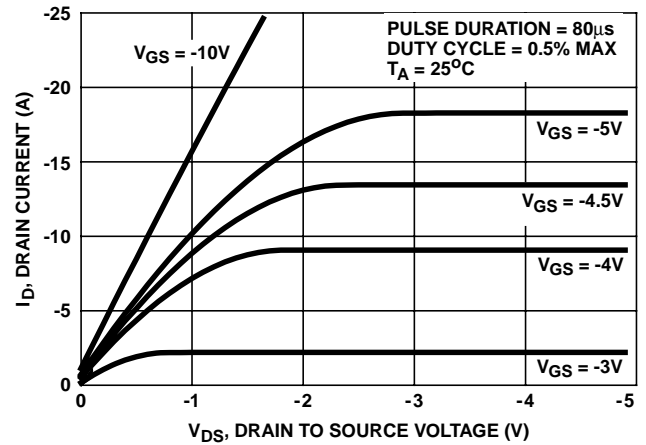

FIGURE 28. SATURATION CHARACTERISTICS

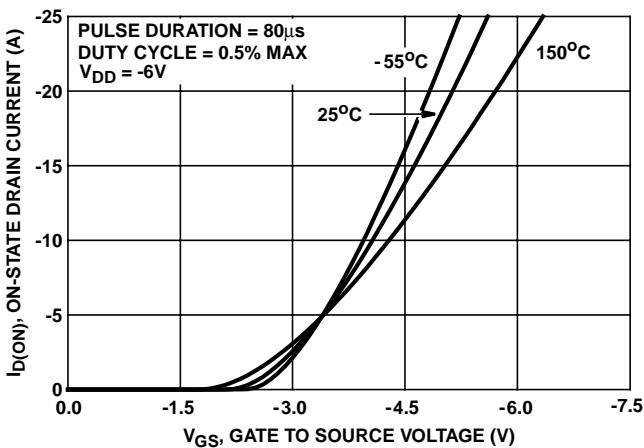

FIGURE 29. TRANSFER CHARACTERISTICS

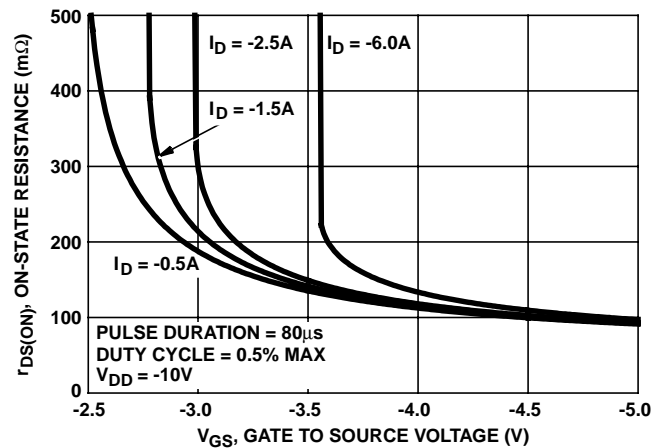

FIGURE 30. DRAIN TO SOURCE ON RESISTANCE vs GATE VOLTAGE AND DRAIN CURRENT

Typical Performance Curves (P-Channel) (Continued)

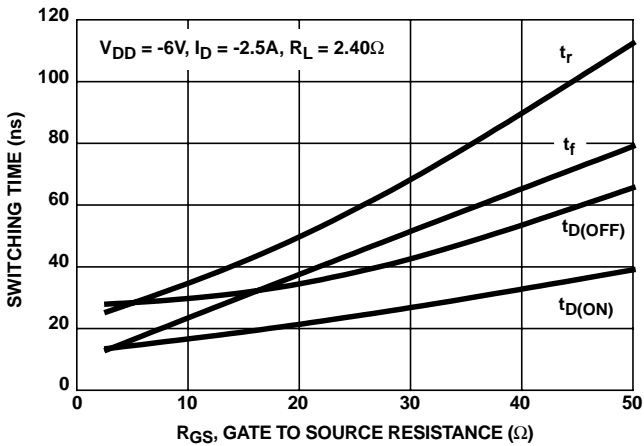

FIGURE 31. SWITCHING TIME AS A FUNCTION OF GATE RESISTANCE

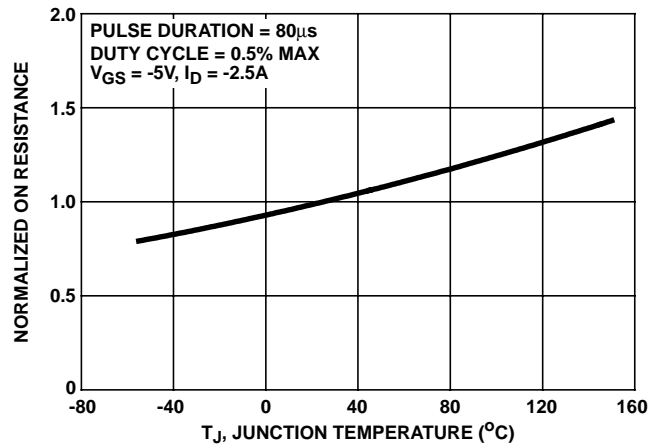

FIGURE 32. NORMALIZED DRAIN TO SOURCE ON RESISTANCE vs JUNCTION TEMPERATURE

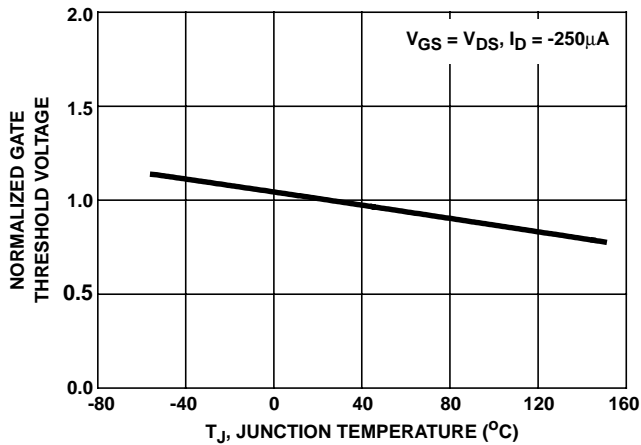

FIGURE 33. NORMALIZED GATE THRESHOLD VOLTAGE vs JUNCTION TEMPERATURE

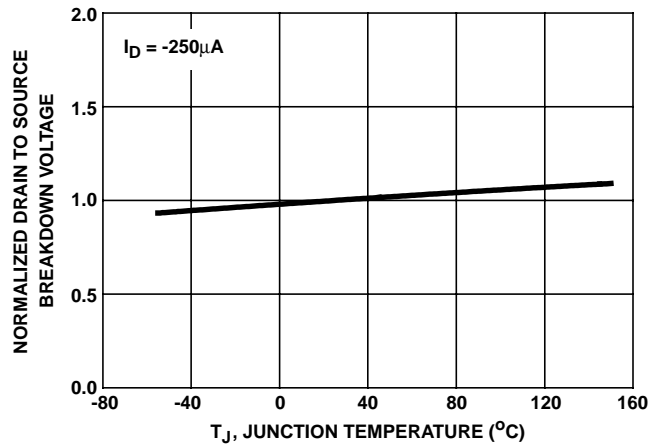

FIGURE 34. NORMALIZED DRAIN TO SOURCE BREAKDOWN VOLTAGE vs JUNCTION TEMPERATURE

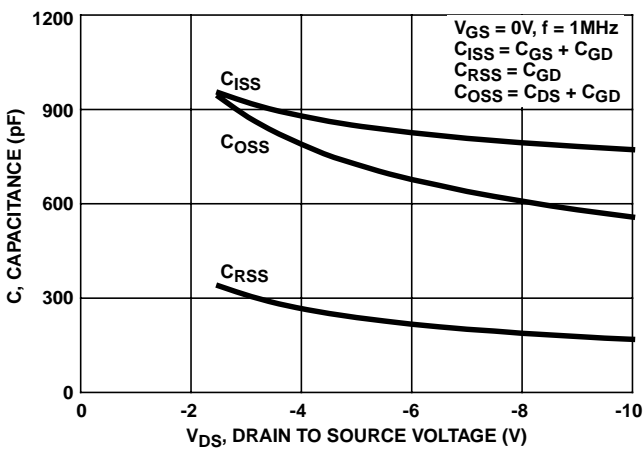
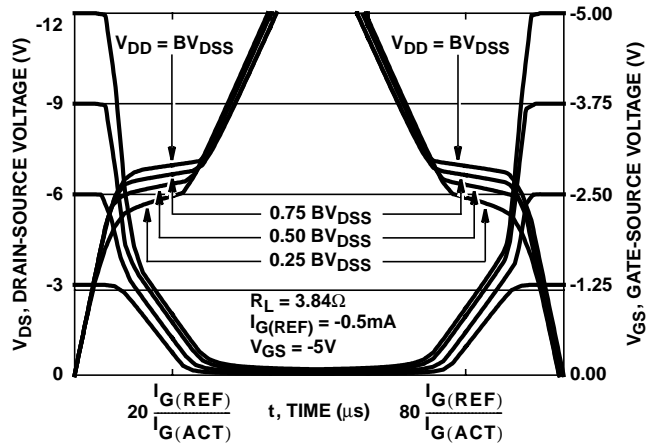

FIGURE 35. CAPACITANCE vs DRAIN TO SOURCE VOLTAGE



NOTE: Refer to Intersil Application Notes AN7254 and AN7260.

FIGURE 36. NORMALIZED SWITCHING WAVEFORMS FOR CONSTANT GATE CURRENT

Test Circuits and Waveforms (P-Channel)

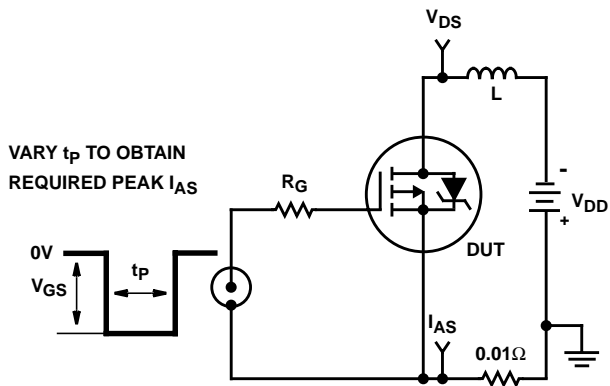

FIGURE 37. UNCLAMPED ENERGY TEST CIRCUIT

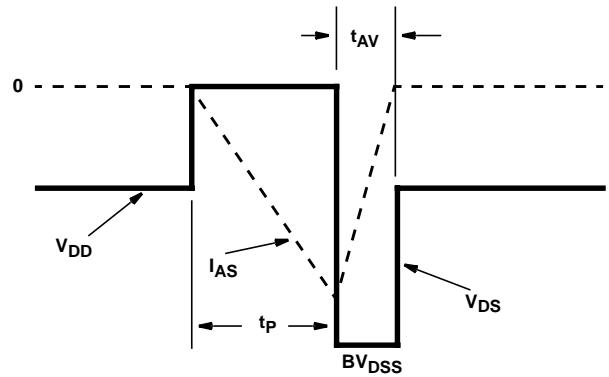

FIGURE 38. UNCLAMPED ENERGY WAVEFORMS

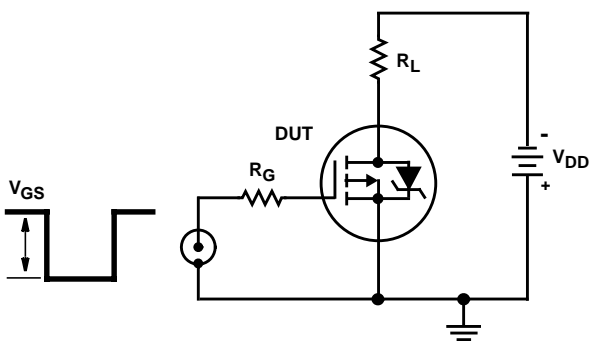

FIGURE 39. SWITCHING TIME TEST CIRCUIT

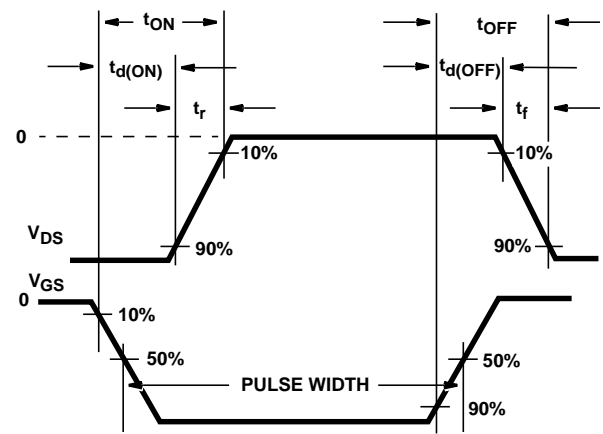

FIGURE 40. RESISTIVE SWITCHING WAVEFORMS

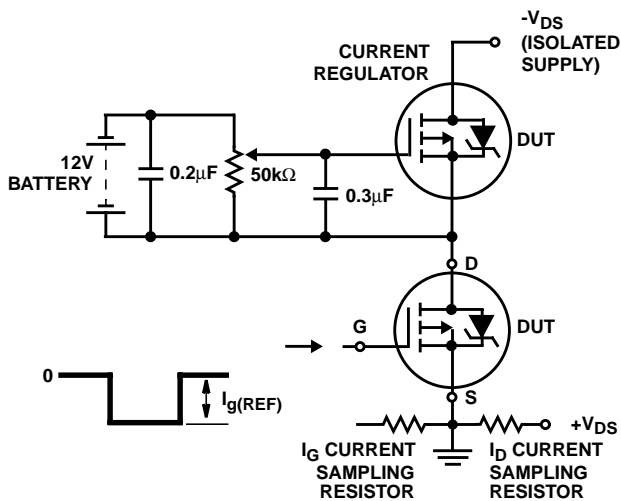

FIGURE 41. GATE CHARGE TEST CIRCUIT

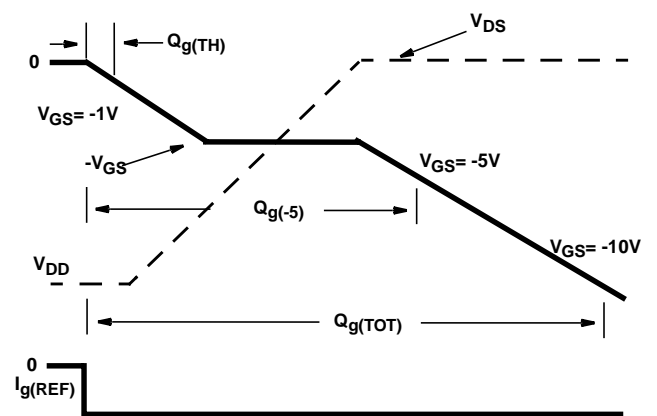

FIGURE 42. GATE CHARGE WAVEFORMS

Soldering Precautions

1. The soldering process creates a considerable thermal stress on any semiconductor component. The melting temperature of solder is higher than the maximum rated temperature of the device. The amount of time the device is heated to a high temperature should be minimized to assure device reliability. Therefore, the following precautions should always be observed in order to minimize the thermal stress to which the devices are subjected.
2. Always preheat the device.
3. The delta temperature between the preheat and soldering should always be less than 100°C. Failure to preheat the device can result in excessive thermal stress which can damage the device.
4. The maximum temperature gradient should be less than 5°C per second when changing from preheating to soldering.
5. The peak temperature in the soldering process should be at least 30°C higher than the melting point of the solder chosen.
6. The maximum soldering temperature and time must not exceed 260°C for 10 seconds on the leads and case of the device.
7. After soldering is complete, the device should be allowed to cool naturally for at least three minutes, as forced cooling will increase the temperature gradient and may result in latent failure due to mechanical stress.
8. During cooling, mechanical stress or shock should be avoided.

PSPICE Electrical Model

SUBCKT RF1K49092 2 1 3; N-Channel Model rev 9/6/94

CA 12 8 9.77e-10
 CB 15 14 9.19e-10
 CIN 6 8 7.81e-10

DBODY 7 5 DBDMOD
 DBREAK 5 11 DBKMOD
 DPLCAP 10 5 DPLCAPMOD

EBREAK 11 7 17 18 14.89
 EDS 14 8 5 8 1
 EGS 13 8 6 8 1
 ESG 6 10 6 8 1
 EVTO 20 6 18 8 1

IT 8 17 1

LDRAIN 2 5 1e-9
 LGATE 1 9 1.233e-9
 LSOURCE 3 7 0.452e-9

MOS1 16 6 8 8 MOSMOD M = 0.99
 MOS2 16 21 8 8 MOSMOD M = 0.01

RBREAK 17 18 RBKMOD 1
 RDRAIN 5 16 RDSMOD 4.91e-3
 RGATE 9 20 2.74
 RIN 6 8 1e9
 RSOURCE 8 7 RDSMOD 5e-3
 RVTO 18 19 RVTOMOD 1

S1A 6 12 13 8 S1AMOD
 S1B 13 12 13 8 S1BMOD
 S2A 6 15 14 13 S2AMOD
 S2B 13 15 14 13 S2BMOD

VBAT 8 19 DC 1
 VTO 21 6 0.3215

.MODEL DBDMOD D (IS = 7.00e-13 RS = 2.15e-2 TRS1 = 0.5e-3 TRS2 = 3.68e-6 CJO = 1.28e-9 TT = 1.8e-8)
 .MODEL DBKMOD D (RS = 1.28e-1 TRS1 = 1.69e-3 TRS2 = -2.0e-6)
 .MODEL DPLCAPMOD D (CJO = 0.84e-9 IS = 1e-30 N = 10)
 .MODEL MOSMOD NMOS (VTO = 1.63 KP = 11.55 IS = 1e-30 N = 10 TOX = 1 L = 1u W = 1u)
 .MODEL RBKMOD RES (TC1 = 9.15e-4 TC2 = 3.13e-7)
 .MODEL RDSMOD RES (TC1 = 7.00e-4 TC2 = 5.00e-6)
 .MODEL RVTOMOD RES (TC1 = -2.155e-3 TC2 = -2.7e-6)
 .MODEL S1AMOD VSWITCH (RON = 1e-5 ROFF = 0.1 VON = -6.05 VOFF = -4.05)
 .MODEL S1BMOD VSWITCH (RON = 1e-5 ROFF = 0.1 VON = -4.05 VOFF = -6.05)
 .MODEL S2AMOD VSWITCH (RON = 1e-5 ROFF = 0.1 VON = -0.72 VOFF = 4.28)
 .MODEL S2BMOD VSWITCH (RON = 1e-5 ROFF = 0.1 VON = 4.28 VOFF = -0.72)

.ENDS

NOTE: For further discussion of the PSPICE model, consult **A New PSPICE Sub-circuit for the Power MOSFET Featuring Global Temperature Options**; IEEE Power Electronics Specialist Conference Records, 1991.

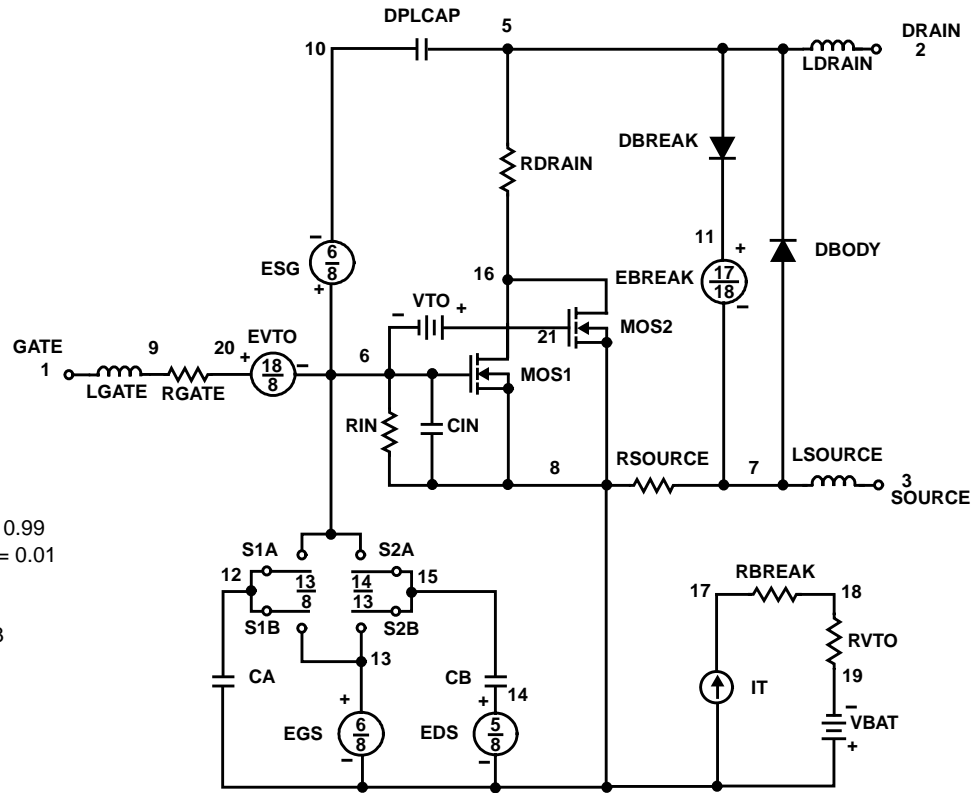

PSPICE Electrical Model

SUBCKT RF1K49092 2 1 3 ; P-Channel Model rev 10/24/94

CA 12 8 8.75e-10
 CB 15 14 8.65e-10
 CIN 6 8 7.65e-10

DBODY 5 7 DBDMOD
 DBREAK 7 11 DBKMOD
 DPLCAP 10 5 DPLCAPMOD

EBREAK 5 11 17 18 -23.75
 EDS 14 8 5 8 1
 EGS 13 8 6 8 1
 ESG 6 10 8 6 1
 EVTO 20 6 8 18 1

IT 8 17 1

LDRAIN 2 5 1e-9
 LGATE 1 9 1.233e-9
 LSOURCE 3 7 0.452e-9

MOS1 16 6 8 8 MOSMOD M = 0.99
 MOS2 16 21 8 8 MOSMOD M = 0.01

RBREAK 17 18 RBKMOD 1
 RDRAIN 5 16 RDSMOD 7.36e-3
 RGATE 9 20 6.1
 RIN 6 8 1e9
 RSOURCE 8 7 RDSMOD 4.56e-2
 RVTO 18 19 RVTOMOD 1

S1A 6 12 13 8 S1AMOD
 S1B 13 12 13 8 S1BMOD
 S2A 6 15 14 13 S2AMOD
 S2B 13 15 14 13 S2BMOD

VBAT 8 19 DC 1
 VTO 21 6 -0.558

.MODEL DBDMOD D (IS = 3.0e-13 RS = 4.4e-2 TRS1 = 1.0e-3 TRS2 = -7.37e-6 CJO = 1.27e-9 TT = 2.2e-8)
 .MODEL DBKMOD D (RS = 7.84e-2 TRS1 = -4.27e-3 TRS2 = 5.77e-5)
 .MODEL DPLCAPMOD D (CJO = 2.85e-10 IS = 1e-30 N = 10)
 .MODEL MOSMOD PMOS (VTO = -2.1423 KP = 9.206 IS = 1e-30 N = 10 TOX = 1 L = 1u W = 1u)
 .MODEL RBKMOD RES (TC1 = 9.61e-4 TC2 = -1.09e-6)
 .MODEL RDSMOD RES (TC1 = 2.10e-3 TC2 = 6.99e-6)
 .MODEL RVTOMOD RES (TC1 = -1.82e-3 TC2 = 1.47e-7)
 .MODEL S1AMOD VSWITCH (RON = 1e-5 ROFF = 0.1 VON = 5.47 VOFF = 3.47)
 .MODEL S1BMOD VSWITCH (RON = 1e-5 ROFF = 0.1 VON = 3.47 VOFF = 5.47)
 .MODEL S2AMOD VSWITCH (RON = 1e-5 ROFF = 0.1 VON = 1.05 VOFF = -3.95)
 .MODEL S2BMOD VSWITCH (RON = 1e-5 ROFF = 0.1 VON = -3.95 VOFF = 1.05)

.ENDS

NOTE: For further discussion of the PSPICE model, consult **A New PSPICE Sub-circuit for the Power MOSFET Featuring Global Temperature Options**; IEEE Power Electronics Specialist Conference Records, 1991.

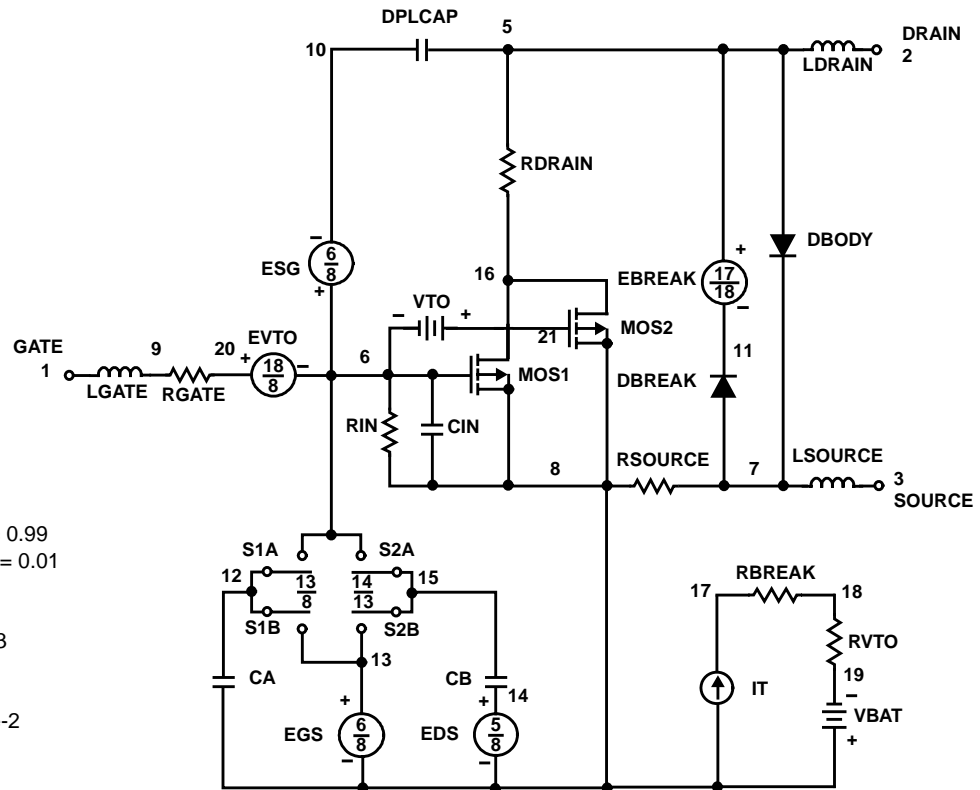

All Intersil semiconductor products are manufactured, assembled and tested under **ISO9000** quality systems certification.

Intersil semiconductor products are sold by description only. Intersil Corporation reserves the right to make changes in circuit design and/or specifications at any time without notice. Accordingly, the reader is cautioned to verify that data sheets are current before placing orders. Information furnished by Intersil is believed to be accurate and reliable. However, no responsibility is assumed by Intersil or its subsidiaries for its use; nor for any infringements of patents or other rights of third parties which may result from its use. No license is granted by implication or otherwise under any patent or patent rights of Intersil or its subsidiaries.

For information regarding Intersil Corporation and its products, see web site <http://www.intersil.com>