

## IS61C6416

### 64K x 16 HIGH-SPEED CMOS STATIC RAM

MAY 1999

#### FEATURES

- High-speed access time: 10, 12, 15, and 20 ns
- CMOS low power operation
  - 1650 mW (max) @ -10ns Cycle
  - 55  $\mu$ W (max) CMOS Standby
- TTL compatible interface levels
- Single 5V  $\pm$  10% power supply
- Fully static operation: no clock or refresh required
- Three state outputs
- Industrial temperature available
- Available in 44-pin SOJ package and 44-pin TSOP (Type II)

#### DESCRIPTION

The *ISSI* IS61C6416 is a high-speed, 1,048,576-bit static RAM organized as 65,536 words by 16 bits. It is fabricated using *ISSI's* high-performance CMOS technology. This highly reliable process coupled with innovative circuit design techniques, yields access times as fast as 10 ns with low power consumption.

When  $\overline{CE}$  is HIGH (deselected), the device assumes a standby mode at which the power dissipation can be reduced down with CMOS input levels.

Easy memory expansion is provided by using Chip Enable and Output Enable inputs,  $\overline{CE}$  and  $\overline{OE}$ . The active LOW Write Enable ( $\overline{WE}$ ) controls both writing and reading of the memory. A data byte allows Upper Byte ( $\overline{UB}$ ) and Lower Byte ( $\overline{LB}$ ) access.

The IS61C6416 is packaged in the JEDEC standard 44-pin 400-mil SOJ and 44-pin TSOP (Type II).

#### FUNCTIONAL BLOCK DIAGRAM

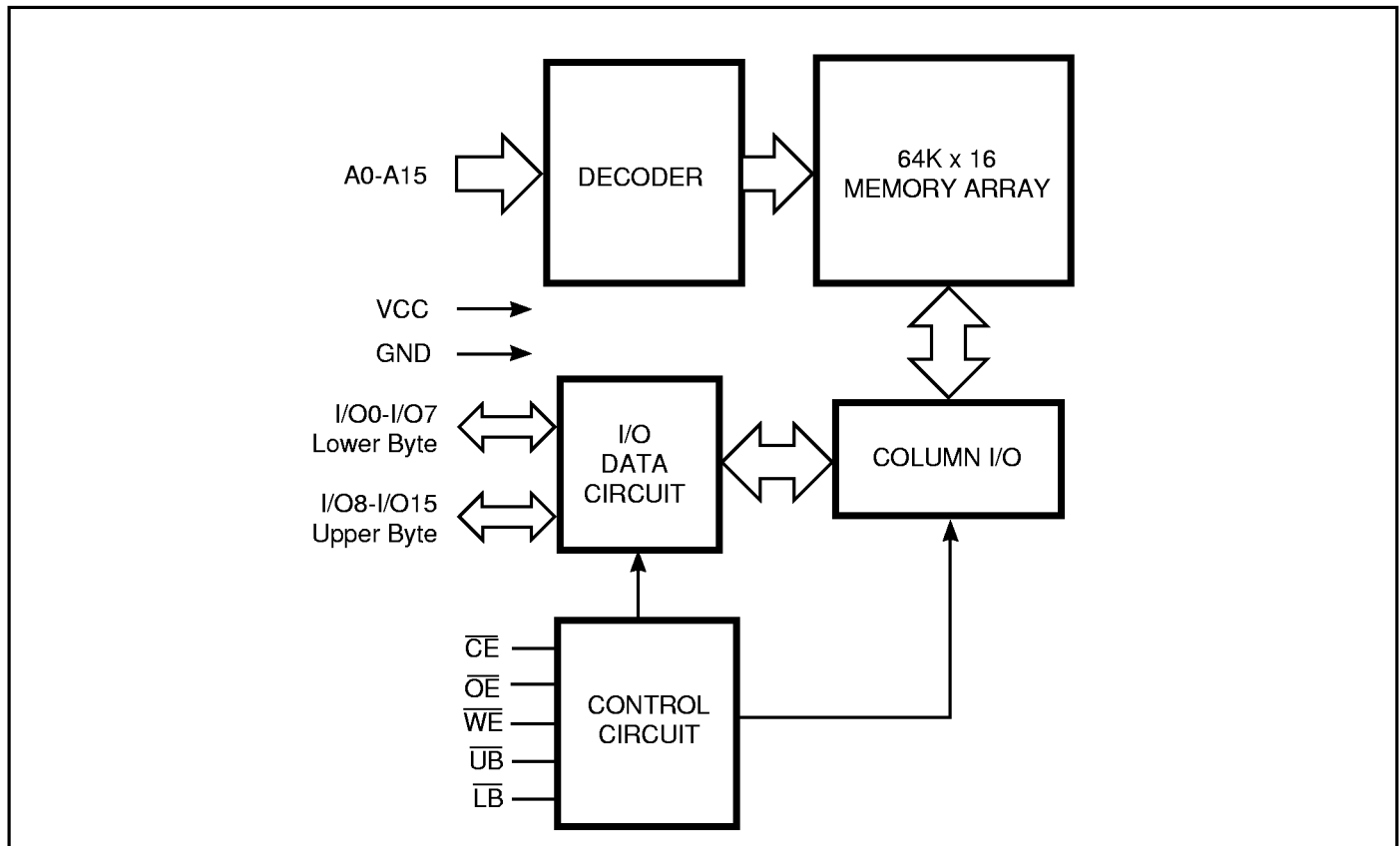

ISSI reserves the right to make changes to its products at any time without notice in order to improve design and supply the best possible product. We assume no responsibility for any errors which may appear in this publication. © Copyright 1999, Integrated Silicon Solution, Inc.

## PIN CONFIGURATIONS

## 44-Pin SOJ

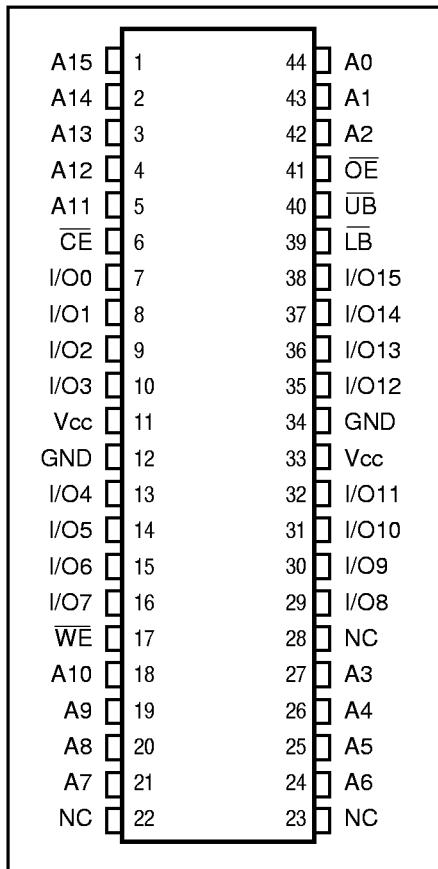

## 44-Pin TSOP (Type II)

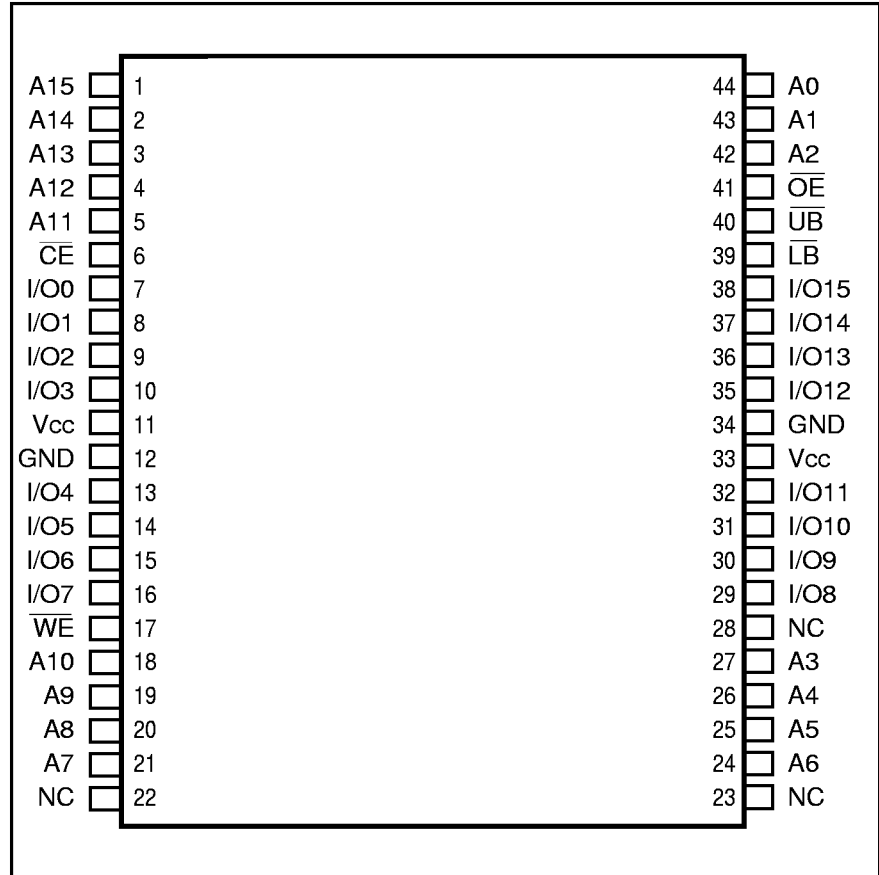

## PIN DESCRIPTIONS

A0-A15	Address Inputs	$\overline{LB}$	Lower-byte Control (I/O0-I/O7)
I/O0-I/O15	Data Inputs/Outputs	$\overline{UB}$	Upper-byte Control (I/O8-I/O15)
$\overline{CE}$	Chip Enable Input	NC	No Connection
$\overline{OE}$	Output Enable Input	Vcc	Power
$\overline{WE}$	Write Enable Input	GND	Ground

## TRUTH TABLE

Mode	$\overline{WE}$	$\overline{CE}$	$\overline{OE}$	$\overline{LB}$	$\overline{UB}$	I/O PIN		Vcc Current
						I/O0-I/O7	I/O8-I/O15	
Not Selected	X	H	X	X	X	High-Z	High-Z	Isb1, Isb2
Output Disabled	H	L	H	X	X	High-Z	High-Z	Icc1, Icc2
	X	L	X	H	H	High-Z	High-Z	
Read	H	L	L	L	H	DOUT	High-Z	Icc1, Icc2
	H	L	L	H	L	High-Z	DOUT	
	H	L	L	L	L	DOUT	DOUT	
Write	L	L	X	L	H	DIN	High-Z	Icc1, Icc2
	L	L	X	H	L	High-Z	DIN	
	L	L	X	L	L	DIN	DIN	

**ABSOLUTE MAXIMUM RATINGS<sup>(1)</sup>**

Symbol	Parameter	Value	Unit
V <sub>TERM</sub>	Terminal Voltage with Respect to GND	-0.5 to +7.0	V
T <sub>STG</sub>	Storage Temperature	-65 to +150	°C
P <sub>T</sub>	Power Dissipation	1.5	W
I <sub>OUT</sub>	DC Output Current (LOW)	20	mA

**Note:**

1. Stress greater than those listed under ABSOLUTE MAXIMUM RATINGS may cause permanent damage to the device. This is a stress rating only and functional operation of the device at these or any other conditions above those indicated in the operational sections of this specification is not implied. Exposure to absolute maximum rating conditions for extended periods may affect reliability.

**OPERATING RANGE**

Range	Ambient Temperature	Speed	V <sub>CC</sub>
Commercial	0°C to +70°C	-10, -12	5V ± 5%
		-15, -20	5V ± 10%
Industrial	-40°C to +85°C	-12	5V ± 5%
		-15, -20	5V ± 10%

**DC ELECTRICAL CHARACTERISTICS (Over Operating Range)**

Symbol	Parameter	Test Conditions	Min.	Max.	Unit
V <sub>OH</sub>	Output HIGH Voltage	V <sub>CC</sub> = Min., I <sub>OH</sub> = -4.0 mA I <sub>OH</sub> = -100 μA	2.4 —	— 3.95	V
V <sub>OL</sub>	Output LOW Voltage	V <sub>CC</sub> = Min., I <sub>OL</sub> = 8.0 mA	—	0.4	V
V <sub>IH</sub>	Input HIGH Voltage		2.2	V <sub>CC</sub> + 0.5	V
V <sub>IL</sub>	Input LOW Voltage <sup>(1)</sup>		-0.5	0.8	V
I <sub>LI</sub>	Input Leakage	GND ≤ V <sub>IN</sub> ≤ V <sub>CC</sub>	-2	2	μA
I <sub>LO</sub>	Output Leakage	GND ≤ V <sub>OUT</sub> ≤ V <sub>CC</sub> , Outputs Disabled	-2	2	μA

**Notes:**

1. V<sub>IL</sub> (min.) = -3.0V for pulse width less than 10 ns.

**POWER SUPPLY CHARACTERISTICS<sup>(1)</sup> (Over Operating Range)**

Symbol	Parameter	Test Conditions	-10		-12		-15		-20		Unit	
			Min.	Max.	Min.	Max.	Min.	Max.	Min.	Max.		
I <sub>CC</sub>	V <sub>CC</sub> Dynamic Operating Supply Current	V <sub>CC</sub> = Max., I <sub>OUT</sub> = 0 mA, f = MAX	Com.	—	300	—	280	—	260	—	235	mA
			Ind.	—	—	—	300	—	290	—	255	
I <sub>SB1</sub>	TTL Standby Current (TTL Inputs)	V <sub>CC</sub> = Max., V <sub>IN</sub> = V <sub>IH</sub> or V <sub>IL</sub> CE ≥ V <sub>IH</sub> , f = max	Com.	—	50	—	50	—	50	—	50	mA
			Ind.	—	—	—	55	—	55	—	55	
I <sub>SB2</sub>	CMOS Standby Current (CMOS Inputs)	V <sub>CC</sub> = Max., CE ≥ V <sub>CC</sub> - 0.2V, V <sub>IN</sub> ≥ V <sub>CC</sub> - 0.2V, or V <sub>IN</sub> ≤ 0.2V, f = 0	Com.	—	10	—	10	—	10	—	10	mA
			Ind.	—	—	—	15	—	15	—	15	

**Note:**

1. At f = f<sub>MAX</sub>, address and data inputs are cycling at the maximum frequency, f = 0 means no input lines change.

CAPACITANCE<sup>(1)</sup>

Symbol	Parameter	Conditions	Max.	Unit
C <sub>IN</sub>	Input Capacitance	V <sub>IN</sub> = 0V	6	pF
C <sub>OUT</sub>	Input/Output Capacitance	V <sub>OUT</sub> = 0V	8	pF

**Note:**

1. Tested initially and after any design or process changes that may affect these parameters.

READ CYCLE SWITCHING CHARACTERISTICS<sup>(1)</sup> (Over Operating Range)

Symbol	Parameter	-10		-12		-15		-20		Unit
		Min.	Max.	Min.	Max.	Min.	Max.	Min.	Max.	
t <sub>RC</sub>	Read Cycle Time	10	—	12	—	15	—	20	—	ns
t <sub>AA</sub>	Address Access Time	—	10	—	12	—	15	—	20	ns
t <sub>OH</sub>	Output Hold Time	3	—	3	—	3	—	4	—	ns
t <sub>ACE</sub>	$\overline{CE}$ Access Time	—	10	—	12	—	15	—	20	ns
t <sub>DOE</sub>	$\overline{OE}$ Access Time	—	5	—	6	—	7	—	9	ns
t <sub>HZOE</sub> <sup>(2)</sup>	$\overline{OE}$ to High-Z Output	—	5	—	6	0	6	0	8	ns
t <sub>LZOE</sub> <sup>(2)</sup>	$\overline{OE}$ to Low-Z Output	0	—	0	—	0	—	0	—	ns
t <sub>HZCE</sub> <sup>(2)</sup>	$\overline{CE}$ to High-Z Output	0	5	0	6	0	6	0	8	ns
t <sub>LZCE</sub> <sup>(2)</sup>	$\overline{CE}$ to Low-Z Output	3	—	3	—	3	—	3	—	ns
t <sub>BA</sub>	$\overline{LB}$ , $\overline{UB}$ Access Time	—	5	—	6	—	7	—	9	ns
t <sub>HZB</sub>	$\overline{LB}$ , $\overline{UB}$ to High-Z Output	0	5	0	6	0	6	0	8	ns
t <sub>LZB</sub>	$\overline{LB}$ , $\overline{UB}$ to Low-Z Output	0	—	0	—	0	—	0	—	ns

**Notes:**

1. Test conditions assume signal transition times of 3 ns or less, timing reference levels of 1.5V, input pulse levels of 0 to 3.0V and output loading specified in Figure 1.
2. Tested with the load in Figure 2. Transition is measured  $\pm 500$  mV from steady-state voltage. Not 100% tested.
3. Not 100% tested.

## AC TEST CONDITIONS

Parameter	Unit
Input Pulse Level	0V to 3.0V
Input Rise and Fall Times	3 ns
Input and Output Timing and Reference Level	1.5V
Output Load	See Figures 1 and 2

## AC TEST LOADS

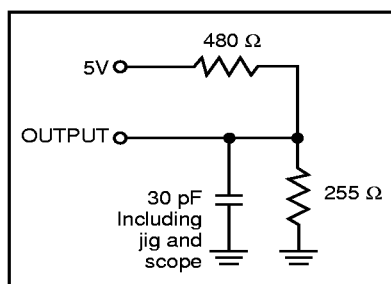

Figure 1

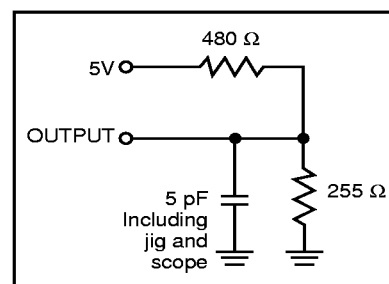
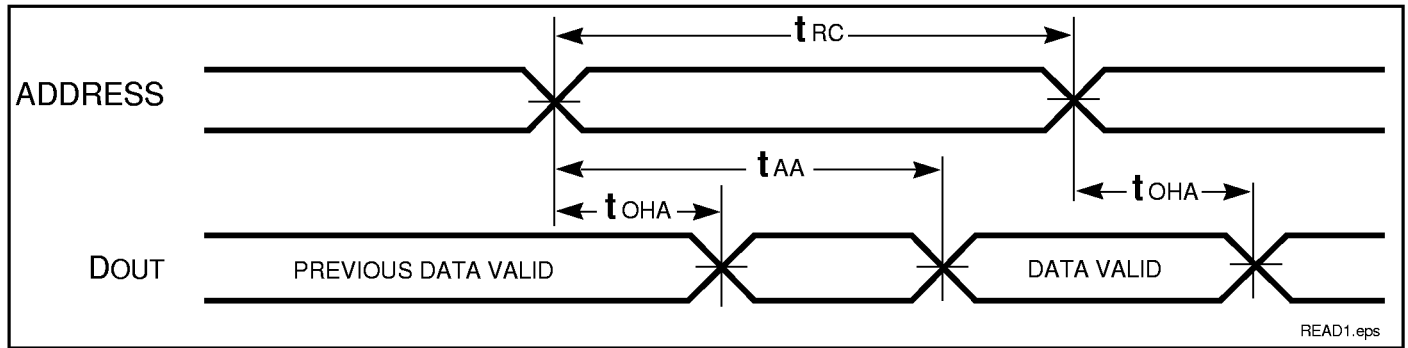

Figure 2

AC WAVEFORMS

READ CYCLE NO. 1<sup>(1,2)</sup> (Address Controlled) ( $\overline{CE} = \overline{OE} = V_{IL}$ ,  $\overline{UB}$  or  $\overline{LB} = V_{IL}$ )



READ CYCLE NO. 2<sup>(1,3)</sup>

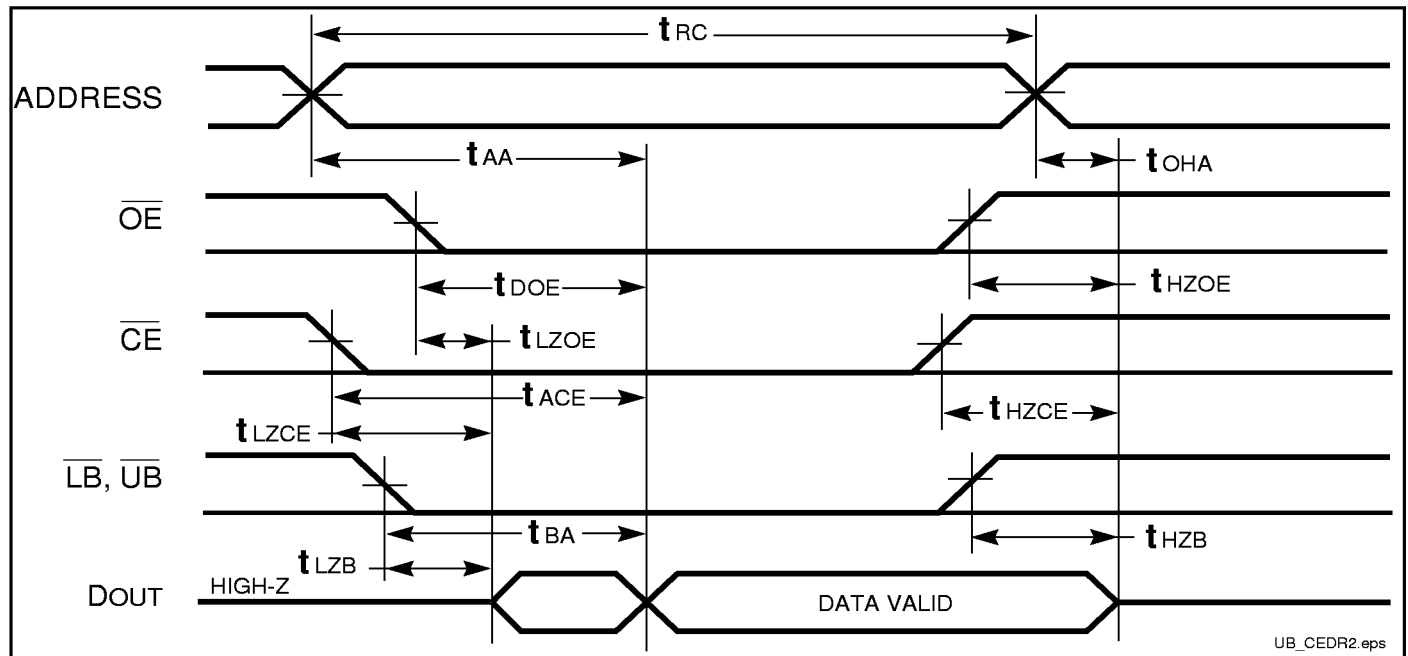

Notes:

1.  $\overline{WE}$  is HIGH for a Read Cycle.
2. The device is continuously selected.  $\overline{OE}$ ,  $\overline{CE}$ ,  $\overline{UB}$ , or  $\overline{LB} = V_{IL}$ .
3. Address is valid prior to or coincident with  $\overline{CE}$  LOW transition.

**WRITE CYCLE SWITCHING CHARACTERISTICS<sup>(1,3)</sup>** (Over Operating Range)

Symbol	Parameter	-10		-12		-15		-20		Unit
		Min.	Max.	Min.	Max.	Min.	Max.	Min.	Max.	
t <sub>WC</sub>	Write Cycle Time	10	—	12	—	15	—	20	—	ns
t <sub>SCE</sub>	$\overline{CE}$ to Write End	8	—	9	—	10	—	12	—	ns
t <sub>AW</sub>	Address Setup Time to Write End	8	—	9	—	10	—	12	—	ns
t <sub>HA</sub>	Address Hold from Write End	0	—	0	—	0	—	0	—	ns
t <sub>SA</sub>	Address Setup Time	0	—	0	—	0	—	0	—	ns
t <sub>PWB</sub>	$\overline{LB}$ , $\overline{UB}$ Valid to End of Write	8	—	9	—	10	—	12	—	ns
t <sub>PWE1</sub>	$\overline{WE}$ Pulse Width ( $\overline{OE}$ =High)	8	—	9	—	10	—	12	—	ns
t <sub>PWE2</sub>	$\overline{WE}$ Pulse Width ( $\overline{OE}$ =Low)	8	—	9	—	10	—	12	—	ns
t <sub>SD</sub>	Data Setup to Write End	6	—	6	—	7	—	9	—	ns
t <sub>HD</sub>	Data Hold from Write End	0	—	0	—	0	—	0	—	ns
t <sub>HZWE<sup>(2)</sup></sub>	$\overline{WE}$ LOW to High-Z Output	—	5	—	6	—	7	—	9	ns
t <sub>LZWE<sup>(2)</sup></sub>	$\overline{WE}$ HIGH to Low-Z Output	3	—	3	—	3	—	3	—	ns

**Notes:**

1. Test conditions assume signal transition times of 3 ns or less, timing reference levels of 1.5V, input pulse levels of 0 to 3.0V and output loading specified in Figure 1.
2. Tested with the load in Figure 2. Transition is measured  $\pm 500$  mV from steady-state voltage. Not 100% tested.
3. The internal write time is defined by the overlap of  $\overline{CE}$  LOW and  $\overline{UB}$  or  $\overline{LB}$ , and  $\overline{WE}$  LOW. All signals must be in valid states to initiate a Write, but any one can go inactive to terminate the Write. The Data Input Setup and Hold timing are referenced to the rising or falling edge of the signal that terminates the write.

## AC WAVEFORMS

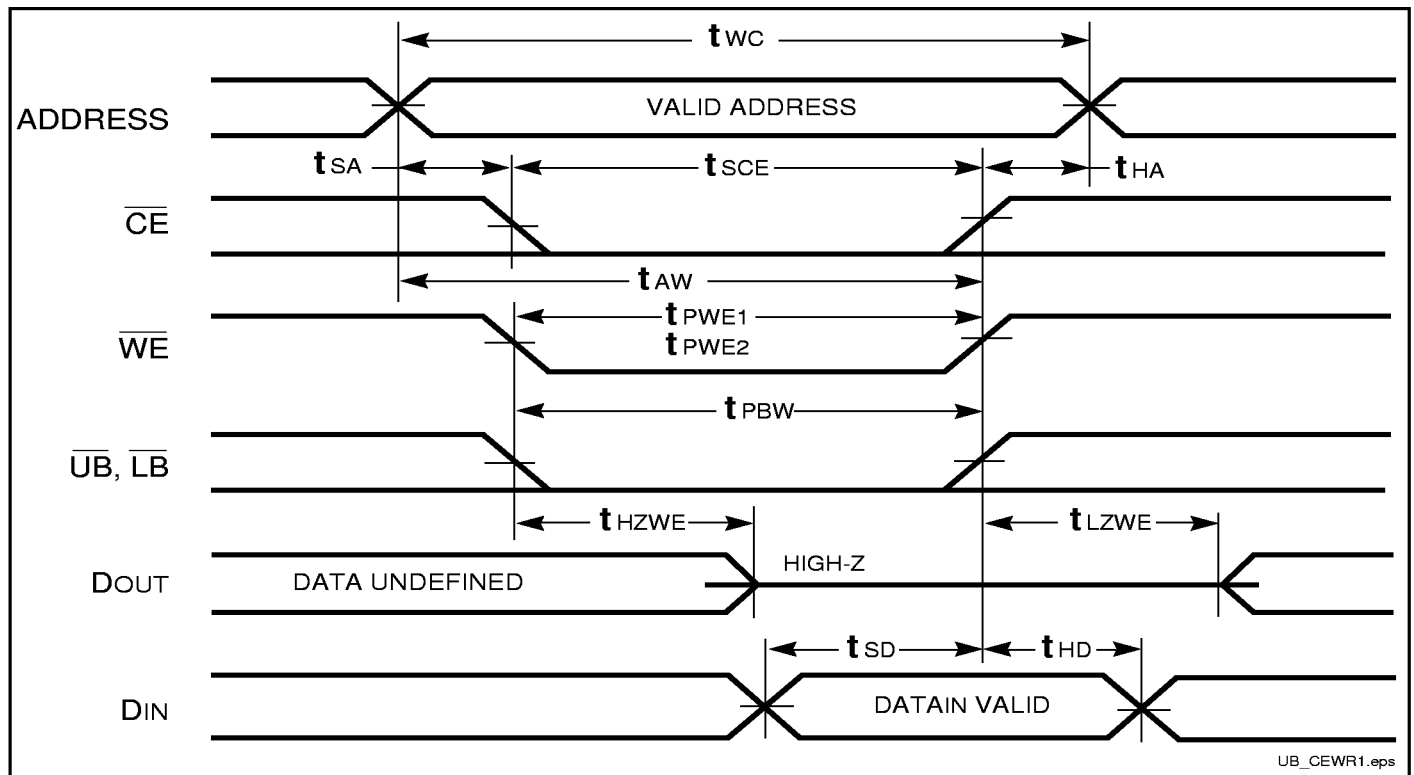
WRITE CYCLE NO. 1 ( $\overline{WE}$  Controlled)<sup>(1,2)</sup>**Notes:**

1. WRITE is an internally generated signal asserted during an overlap of the LOW states on the  $\overline{CE}$  and  $\overline{WE}$  inputs and at least one of the  $\overline{LB}$  and  $\overline{UB}$  inputs being in the LOW state.
2. WRITE =  $(\overline{CE}) [ (\overline{LB}) = (\overline{UB}) ] (\overline{WE})$ .

**WRITE CYCLE NO. 2** ( $\overline{OE}$  is HIGH During Write Cycle) <sup>(1,2)</sup>

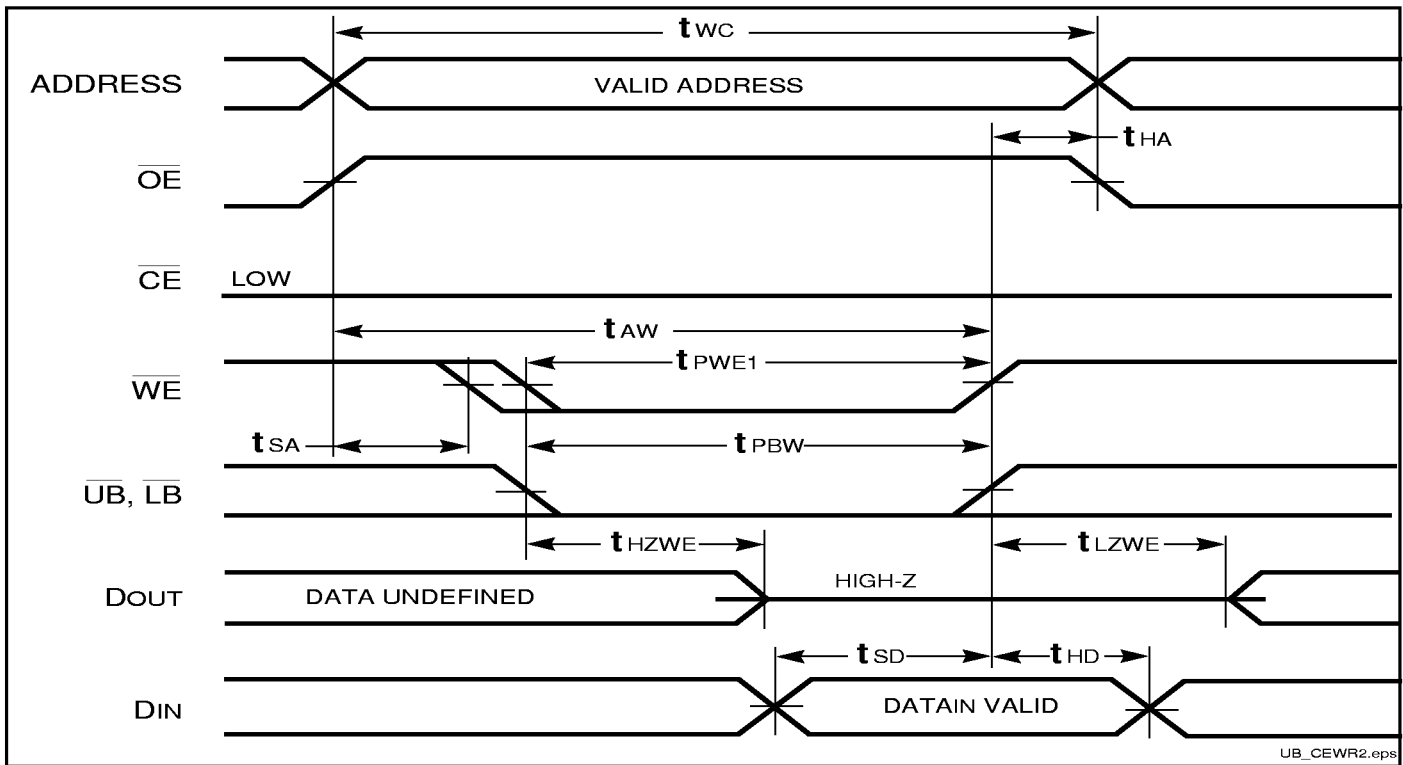

**WRITE CYCLE NO. 3** ( $\overline{OE}$  is LOW During Write Cycle) <sup>(1)</sup>

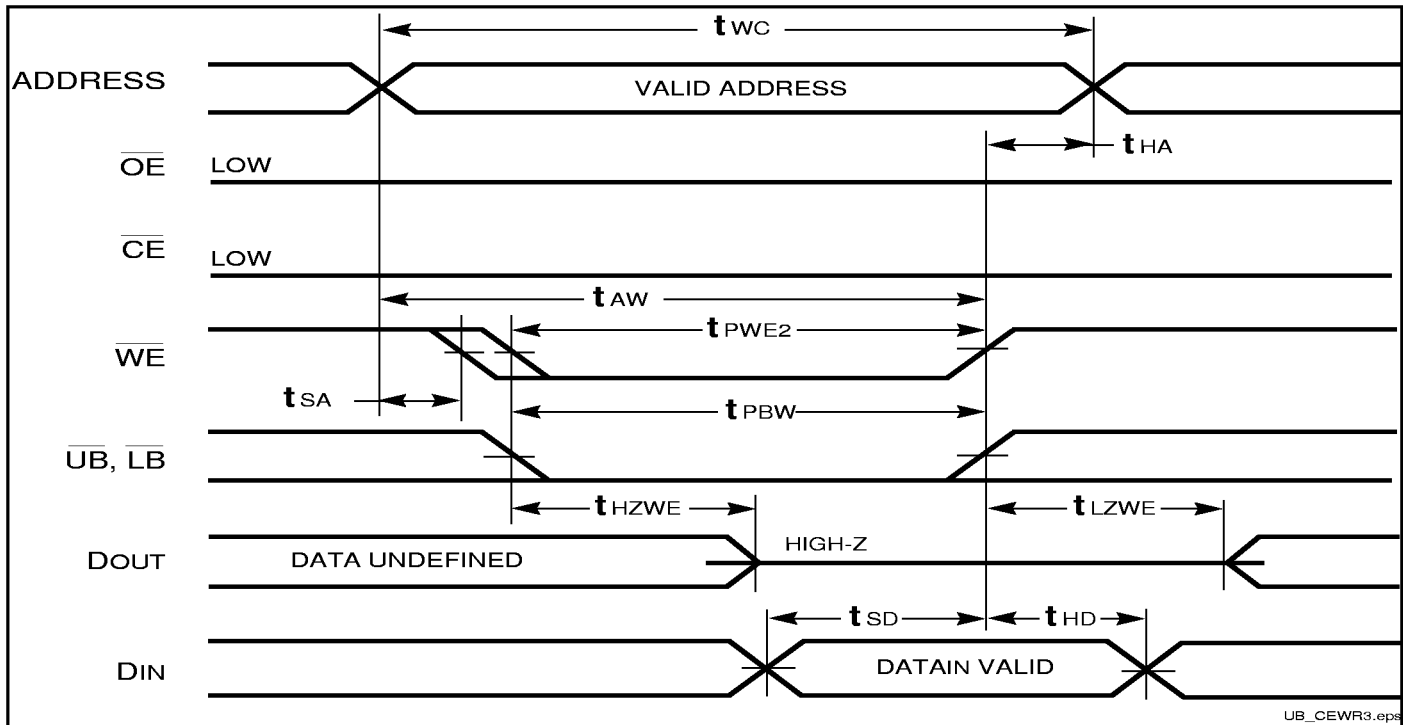

**Notes:**

1. The internal write time is defined by the overlap of  $\overline{CE}$  LOW and  $\overline{WE}$  LOW. All signals must be in valid states to initiate a Write, but any one can go inactive to terminate the Write. The Data Input Setup and Hold timing are referenced to the rising or falling edge of the signal that terminates the Write.
2. I/O will assume the High-Z state if  $\overline{OE} \geq V_{IH}$ .



WRITE CYCLE NO. 4 ( $\overline{UB}/\overline{LB}$  Back to Back Write)

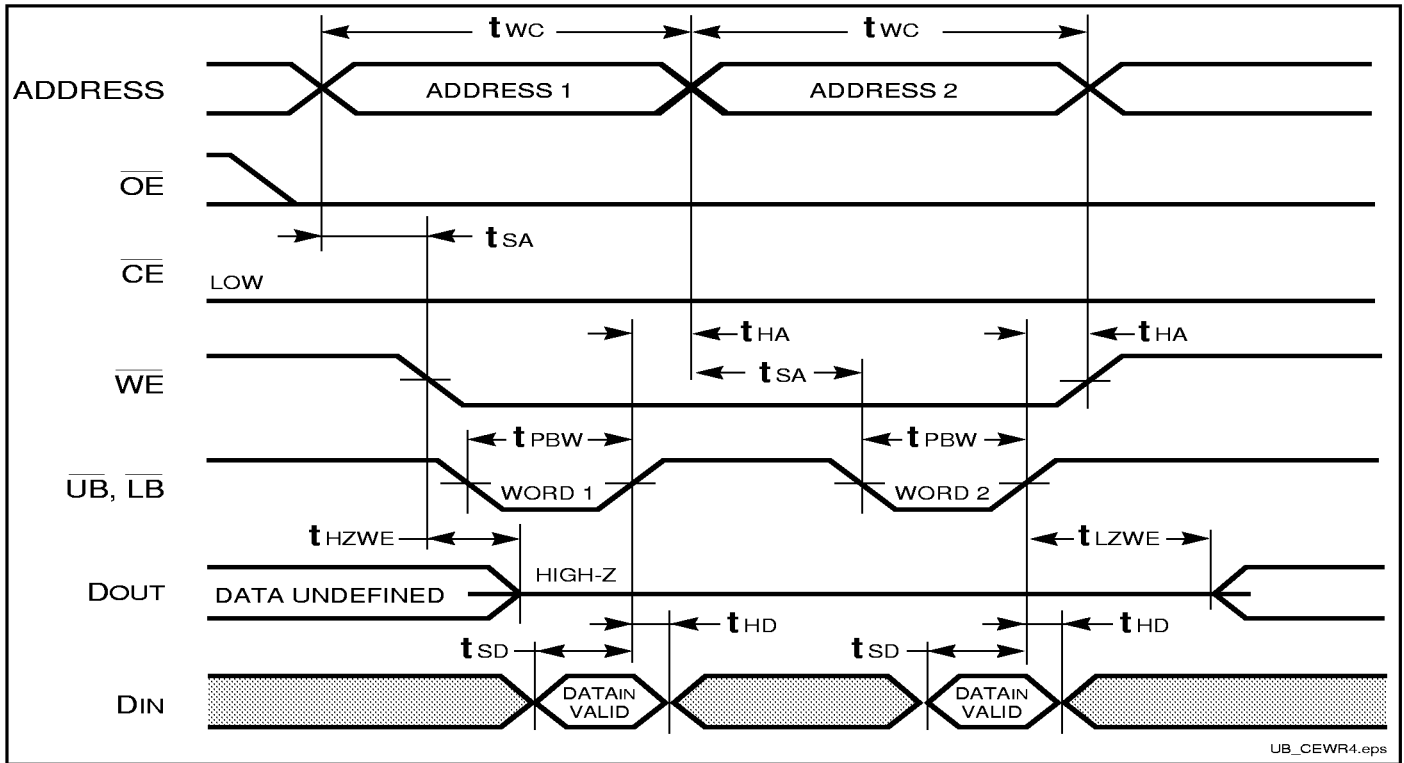

ORDERING INFORMATION

Commercial Range: 0°C to +70°C

Speed (ns)	Order Part No.	Package
10	IS61C6416-10T	Plastic TSOP(II)
10	IS61C6416-10K	400-mil Plastic SOJ
12	IS61C6416-12T	Plastic TSOP(II)
12	IS61C6416-12K	400-mil Plastic SOJ
15	IS61C6416-15T	Plastic TSOP(II)
15	IS61C6416-15K	400-mil Plastic SOJ
20	IS61C6416-20T	Plastic TSOP(II)
20	IS61C6416-20K	400-mil Plastic SOJ

ORDERING INFORMATION

Industrial Range: -40°C to +85°C

Speed (ns)	Order Part No.	Package
12	IS61C6416-12TI	Plastic TSOP(II)
12	IS61C6416-12KI	400-mil Plastic SOJ
15	IS61C6416-15TI	Plastic TSOP(II)
15	IS61C6416-15KI	400-mil Plastic SOJ
20	IS61C6416-20TI	Plastic TSOP(II)
20	IS61C6416-20KI	400-mil Plastic SOJ