

TOSHIBA CMOS DIGITAL INTEGRATED CIRCUIT SILICON MONOLITHIC

T6M74A, JT6M74A-AS

T6M74A, JT6M74A-AS, CMOS 1 CHIP LSI FOR LCD ELECTRONIC CALCULATOR

The T6M74A, JT6M74A-AS is a CMOS 1 chip microcomputer for 16-digits capacity 1-memory electronic calculation.

T6M74A, JT6M74A-AS is the complete single chip CMOS LSI for electronic calculator with single power supply operation.

Wide operating voltage range and low power consumption make it suitable for 1.5V solar battery operated.

Besides T6M74A, JT6M74A-AS can be selectable with a pin-programmable to function of Power timer and Memory hold. With the following features.

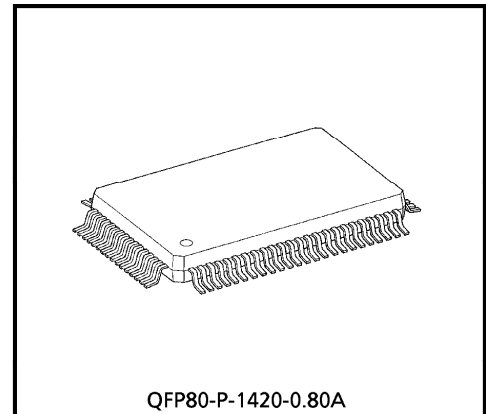

Weight : 1.52g (Typ.)

FEATURES

- Display : 16-digits of data, 1-digits of sign, error symbol, memory load symbol.
- Algebraic mode.
- Standard 4 functions (+, -, ×, ÷)
- Automatic percentage operation with add-on, discount.
- Automatic delta percentage, mark-up and markdown operations.
- Square root.
- Constant calculation.
- Chain calculation.
- Change sign.
- Floating point or momentary mode (selectable with a switch).
- Fixed point ("0", "1", "2", "3", "4" or "6" places) or floating point (selectable with a switch).
- Adding point mode (selectable with a switch).

980910EBA2

- TOSHIBA is continually working to improve the quality and the reliability of its products. Nevertheless, semiconductor devices in general can malfunction or fail due to their inherent electrical sensitivity and vulnerability to physical stress. It is the responsibility of the buyer, when utilizing TOSHIBA products, to observe standards of safety, and to avoid situations in which a malfunction or failure of a TOSHIBA product could cause loss of human life, bodily injury or damage to property. In developing your designs, please ensure that TOSHIBA products are used within specified operating ranges as set forth in the most recent products specifications. Also, please keep in mind the precautions and conditions set forth in the TOSHIBA Semiconductor Reliability Handbook.
- The products described in this document are subject to the foreign exchange and foreign trade laws.
- The information contained herein is presented only as a guide for the applications of our products. No responsibility is assumed by TOSHIBA CORPORATION for any infringements of intellectual property or other rights of the third parties which may result from its use. No license is granted by implication or otherwise under any intellectual property or other rights of TOSHIBA CORPORATION or others.
- The information contained herein is subject to change without notice.

- Rounding switches (rounding up, down and off).
- Leading zero suppression.
- Trailing zero suppression.
- Punctuation on display, commas for thousands.
- Memory contents indicator, turned on with non-zero in the memory.
- Registration overflow, indicating that too many digits are entered (the most significant digit are protected).
- Result overflow, indicating during calculation (most function key are locked as it happened).
- Memory overflow indicating to flashing of memory load mark.
- Key roll over function.
- Floating minus.

SYSTEM BLOCK DIAGRAM

Battery Type

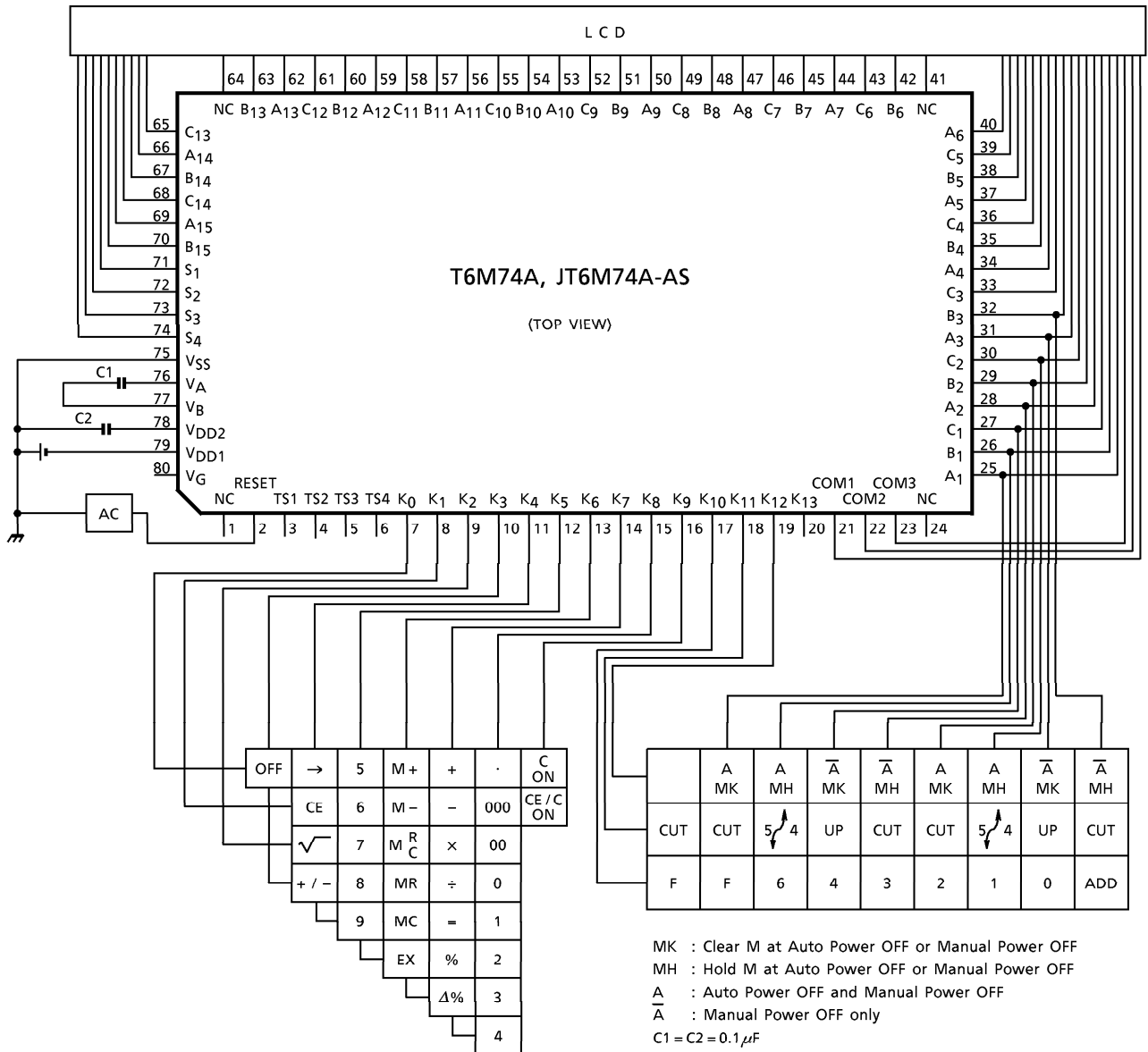

Dual Type

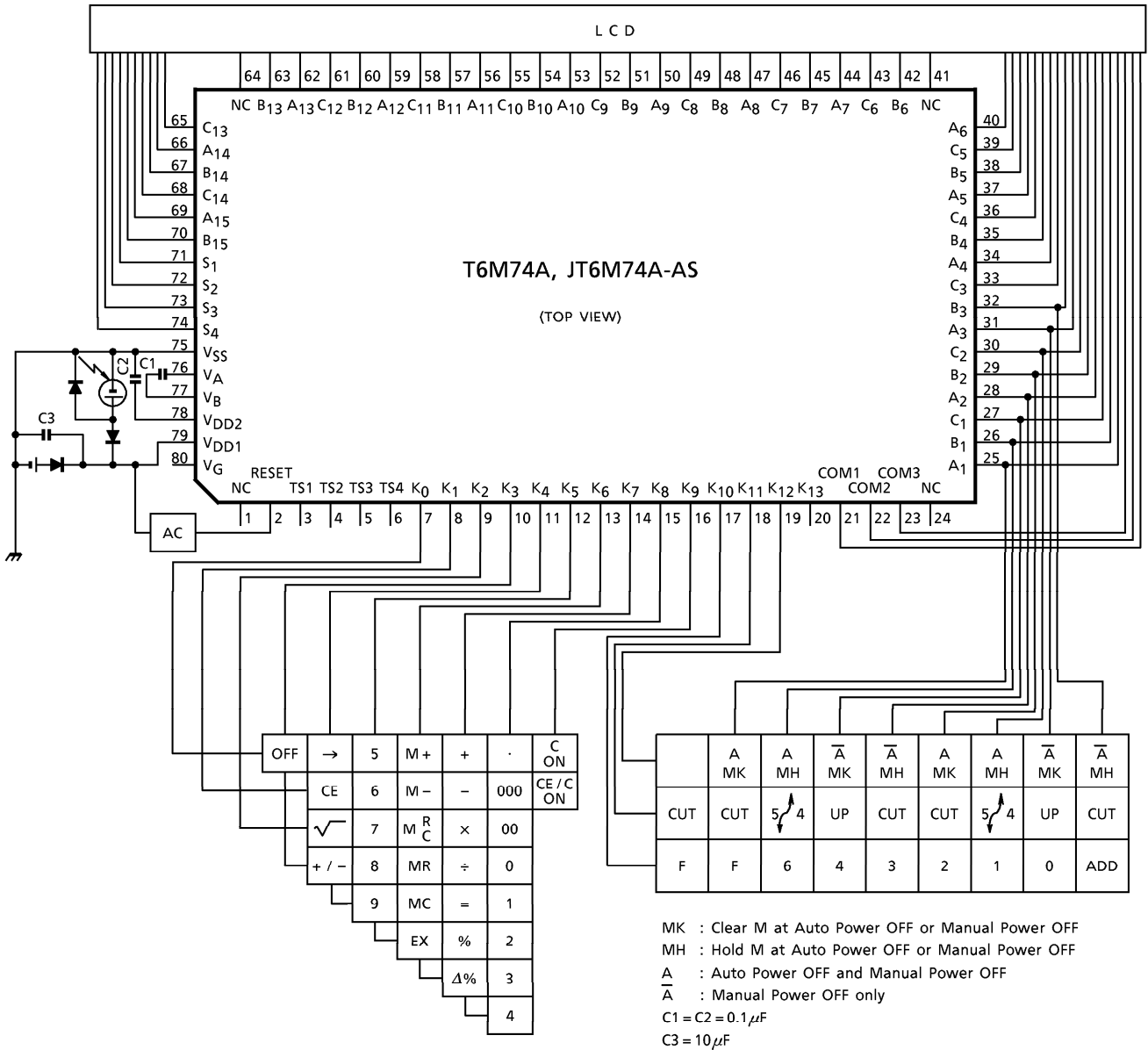

Solar Type

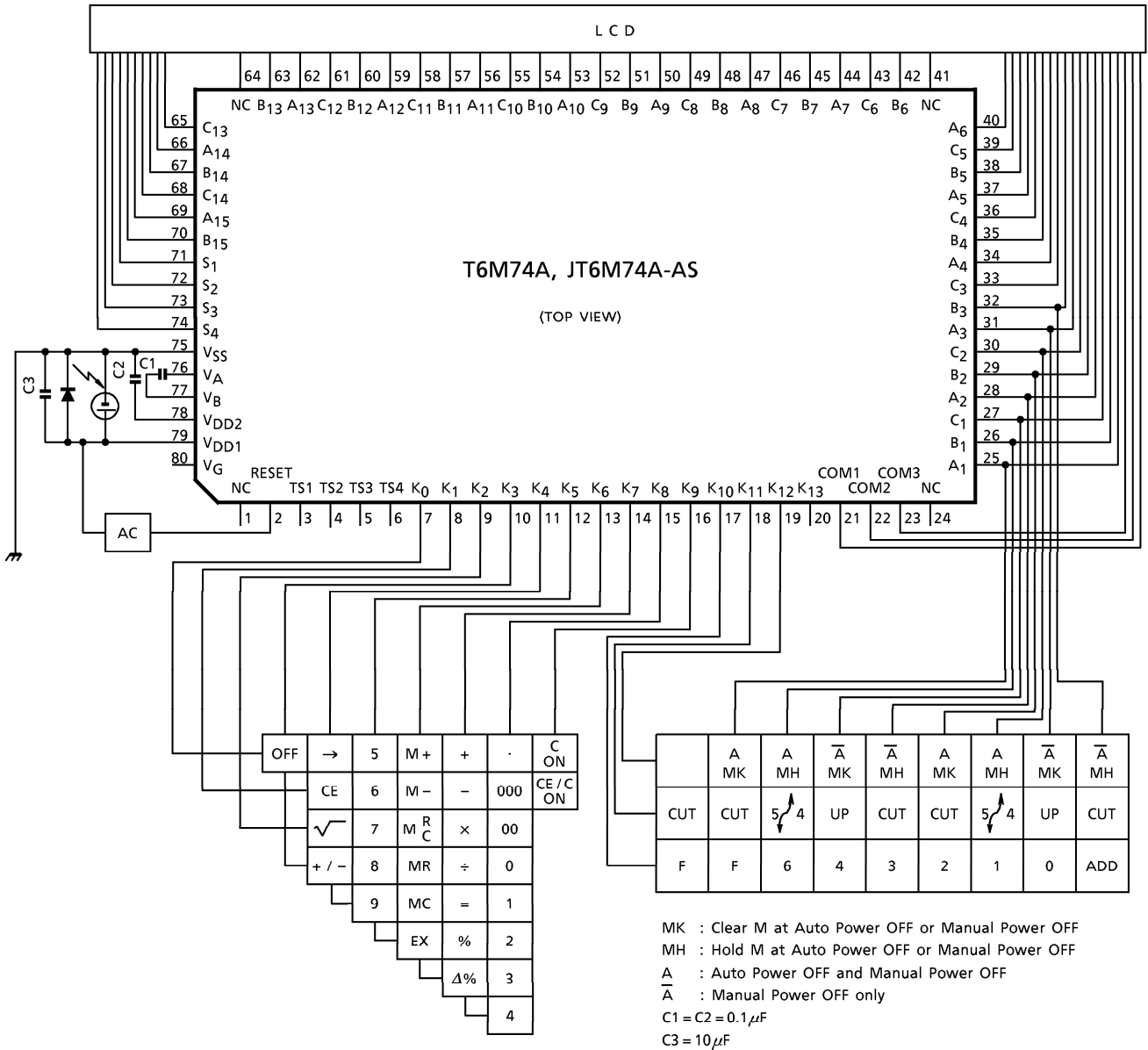

CONNECTION OF LCD

(1)

SEGMENT

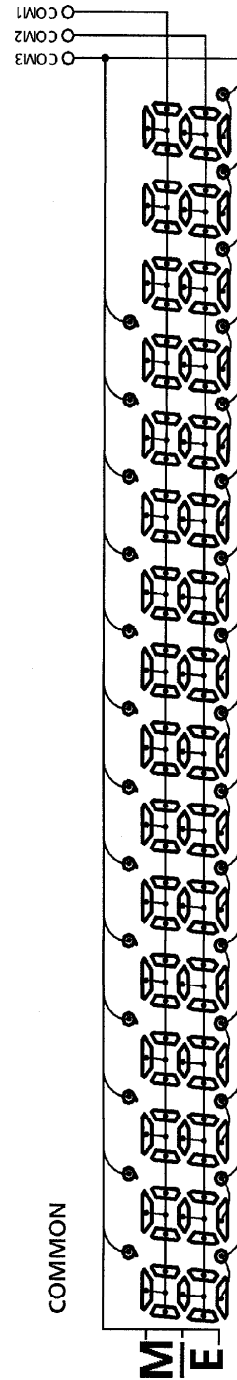
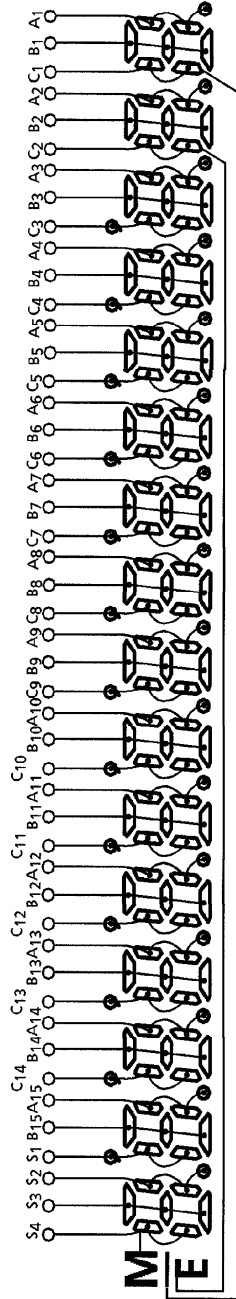

COMMON

T6M74A, JT6M74A-AS - 6

KEY LAYOUT

- Touch key

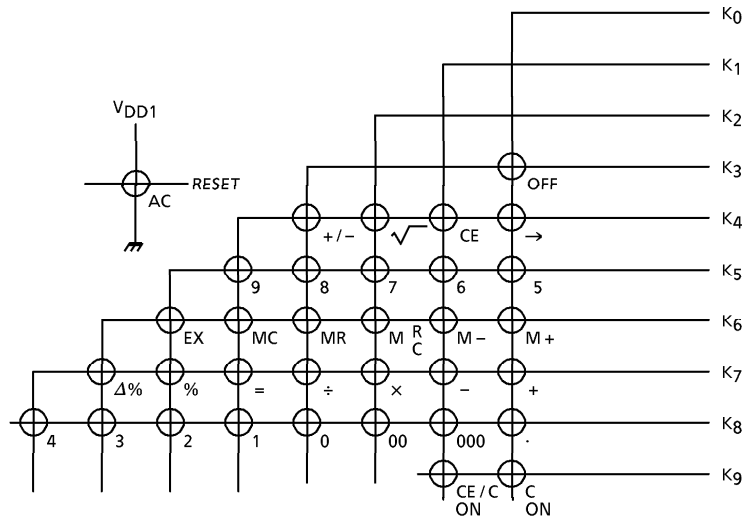

- Lock key

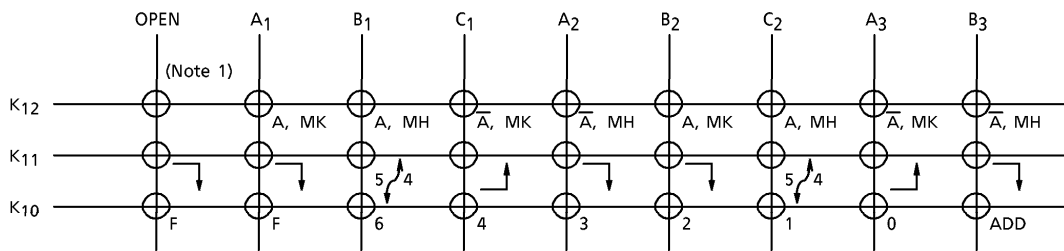

K₁₂ ... Selectable with Auto Power OFF mode and Memory Hold Status. MH (Memory Hold). MK (Memory Kill)
 K₁₁ ... Rounding switches.
 K₁₀ ... Selectable with Fixed point or Floating mode.

(Note 1)

K₁₂ line is No choose then keep condition.

K₁₂ line is No choose at the system power on then initial condition is \bar{A} , MH Mode selected.

PIN LAYOUT

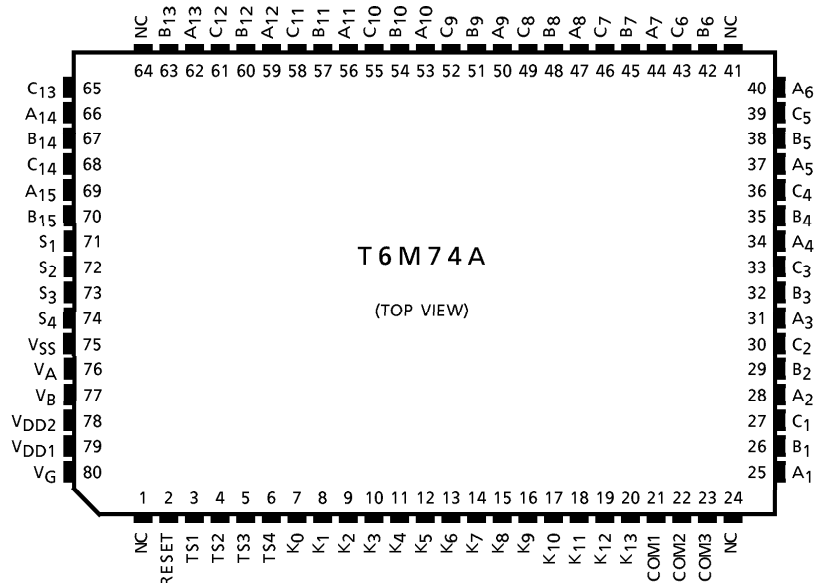

SPECIFICATION OF CALCULATOR

Speed of calculation

Numeral	27.8~40.9ms
Function	{ 1 $\boxed{+}$	42.7ms
	{ 1 $\boxed{+}$ 2 $\boxed{+}$	83.9ms
Addition and subtract	{ 123 $\boxed{+}$ 1 $\boxed{=}$	82.8ms
	{ 9999999999999999 $\boxed{-}$ 0.000000000000001 $\boxed{=}$	106.4ms
Multiply	{ 123 $\boxed{\times}$ 2 $\boxed{=}$	110.8ms
	{ 1 $\boxed{\times}$ 9999999999999999 $\boxed{=}$	309.9ms
Device	{ 123 $\boxed{\div}$ 3 $\boxed{=}$	165.1ms
	{ 9999999999999999 $\boxed{\div}$ 1 $\boxed{=}$	348.4ms
Memory calculation	{ 2 $\boxed{M+}$	93.8ms
	{ 9999999999999999 $\boxed{\div}$ 1 $\boxed{M+}$	388.1ms
Square root	{ 9999999999999999 $\boxed{\sqrt{\quad}}$	259.7ms
	{ 2 $\boxed{\sqrt{\quad}}$	170.2ms

Operation example

1. Fixed point calculations

① Key	Display	Fixed point place	② Key	Display	Fixed point place
\boxed{C}	0.	DP = 3 (5 / 4)	\boxed{C}	0.	DP = 0 ($\underline{\quad}$ ↑)
2	2.		1	1.	
$\boxed{\div}$	2.		$\boxed{\cdot}$	1.	
3	3.		2	1.2	
$\boxed{=}$	0.667		3	1.23	
2	2.		$\boxed{+}$	1.23	
$\boxed{\cdot}$	2.		1	1.	
3	2.3		$\boxed{\cdot}$	1.	
$\boxed{+}$	2.3		1	1.1	
4	4.		$\boxed{=}$	3.	
$\boxed{M+}$	6.300		9	9.	
1	1.		$\boxed{\sqrt{\quad}}$	3.	
$\boxed{\cdot}$	1.		$\boxed{\times}$	3.	
2	1.2		1	1.	
$\boxed{M+}$	1.200		$\boxed{\cdot}$	1.	
\boxed{MR}	7.5	DP = 4	1	1.1	DP = F
			$\boxed{=}$	3.3	

2. Adding point mode calculations

Key	Display	Key	Display	Key	Display
\boxed{C}	0.	$\boxed{M+}$	0.02M	$\boxed{=}$	33.27M -
1	1.	3	3.M	2	2.M
23	123	$\boxed{\cdot}$	3.M	$\boxed{+}$	0.02M
$\boxed{+}$	1.23	123	3.123M	9	9.M
3	3.	$\boxed{M+}$	3.12M	$\boxed{\cdot}$	9.M
$\boxed{=}$	1.26	\boxed{MR}	3.14M	$\boxed{\sqrt{\quad}}$	3.M
3	3.	\boxed{C}	0.M	$\boxed{=}$	3.02M
2	32.	1	1.M		
$\boxed{\times}$	32.	23	123M		
3	3.	$\boxed{-}$	1.23M		
$\boxed{\cdot}$	3.	3	3.M		
000	3.000	4	34.M		
$\boxed{=}$	96.00	$\boxed{\cdot}$	34.M		
2	2.	5	34.5M		

3. Constant calculations

① Multiplication

Key	Display	Constant
k	k	
$\boxed{\times}$	k	
a	a	
$\boxed{=}$	k·a	k ×
b	b	k ×
$\boxed{=}$	k·b	k ×

② Division

Key	Display	Constant
a	a	
$\boxed{\div}$	a	
k	k	
$\boxed{=}$	a / k	÷ k
b	b	÷ k
$\boxed{=}$	b / k	÷ k

③ Addition

a	a	
$\boxed{+}$	a	
k	k	
$\boxed{=}$	a + k	+ k
b	b	+ k
$\boxed{=}$	b + k	+ k

④ Subtraction

a	a	
$\boxed{-}$	a	
k	k	
$\boxed{=}$	a - k	- k
b	b	- k
$\boxed{=}$	b - k	- k

⑤ Percentage

Key	Display	Constant
k	k	
\times	k	
a	a	
$\%$	$k \cdot a / 100$	$k \times$
b	b	$k \times$
$\%$	$k \cdot b / 100$	$k \times$

⑦ Add-on

k	k	
$+$	k	
a	a	
$\%$	$k \cdot (1 + a / 100)$	$k +$
b	b	$k +$
$\%$	$k \cdot (1 + b / 100)$	$k +$

4. $\Delta\%$ calculations

① Key Display

a	a
$+$	a
b	b
$\Delta\%$	$100 \cdot (a + b) / b$

⑥ Percentage

Key	Display	Constant
a	a	
\div	a	
k	k	
$\%$	$100 \cdot a / k$	$\div k$
b	b	$\div k$
$\%$	$100 \cdot b / k$	$\div k$

⑧ Discount

k	k	
$-$	k	
a	a	
$\%$	$k \cdot (1 - a / 100)$	$k -$
b	b	$k -$
$\%$	$k \cdot (1 - b / 100)$	$k -$

② Key Display

a	a
$-$	a
b	b
$\Delta\%$	$100 \cdot (a - b) / b$

5. Mark-up, mark-down calculations

① Mark-up

Key	Display
a	a
\div	a
b	b
$\Delta\%$	$a / (1 - b / 100)$
$\Delta\%$	$ a / (1 - b / 100) $

② Mark-down

Key	Display
a	a
\div	a
b	b
$+/-$	-b
$\Delta\%$	$a / (1 + b / 100)$
$\Delta\%$	$a / (1 + b / 100) - a1$

6. Add-on, discount calculations

Add-on

	Key	Display
①	a	a
	$\boxed{\times}$	a
	b	b
	$\boxed{\%}$	$a \cdot b / 100$
	$\boxed{+}$	$a \cdot b / 100$
	$\boxed{=}$	$a (1 + b / 100)$
③	a	a
	$\boxed{+}$	a
	b	b
	$\boxed{\%}$	$a (1 + b / 100)$
⑤	a	a
	$\boxed{\times}$	a
	b	b
	$\boxed{\Delta\%}$	$a \cdot (1 + b / 100)$

Discount

	Key	Display
②	a	a
	$\boxed{\times}$	a
	b	b
	$\boxed{\%}$	$a \cdot b / 100$
	$\boxed{-}$	$a \cdot b / 100$
	$\boxed{=}$	$a (1 - b / 100)$
④	a	a
	$\boxed{-}$	a
	b	b
	$\boxed{\%}$	$a (1 - b / 100)$
⑥	a	a
	$\boxed{\times}$	a
	b	b
	$\boxed{+/-}$	- b
	$\boxed{\Delta\%}$	$a (1 - b / 100)$

MAXIMUM RATINGS

ITEM	SYMBOL	LIMITS	UNIT
Supply Voltage	V _{DD1}	-0.3~2.0	V
Input Voltage	V _{IN}	-0.3~V _{DD1} +0.3	V
Operating Temperature	T _{opr}	0~40	°C
Storage Temperature	T _{stg}	-55~125	°C

ELECTRICAL CHARACTERISTICS (V_{DD1} = 1.5 ± 0.2V, V_{DD2} = 3.0 ± 0.4V, V_{SS} = 0V, Ta = 25°C)

ITEM	SYMBOL	TEST CIR-CUIT	PIN NAME	TEST CONDITION	MIN.	TYP.	MAX.	UNIT
Operating Voltage	V _{DD1}	—	—	—	1.2	1.5	2.0	V
"1" Input Voltage	V _{IH} (1)	—	K ₂ ~K ₉ RESET	—	V _{DD1} -0.4	—	V _{DD1}	V
"1" Input Voltage	V _{IH} (2)	—	K ₁₀ ~K ₁₃	—	V _{DD2} -0.4	—	V _{DD2}	V
"0" Input Voltage	V _{IL}	—	K ₂ ~K ₁₃ RESET	—	0	—	0.4	V
"1" Output Voltage	V _{OH} (1)	—	SEGMENT COM1~3	—	V _{DD2} -0.2	—	V _{DD2}	V
"0" Output Voltage	V _{OL} (1)	—	SEGMENT COM1~3	—	0	—	0.2	V
"M" Output Voltage	V _{OM}	—	COM1~3	—	V _{DD1} -0.2	—	V _{DD1} +0.2	V
"1" Output Voltage	V _{OH} (2)	—	K ₁ ~K ₉	—	V _{DD1} -0.2	—	V _{DD1}	V
"0" Output Voltage	V _{OL} (2)	—	K ₁ ~K ₁₃	—	0	—	0.2	V
"1" Output Resistance	R _{OH}	—	SEGMENT COM1~3	V _{OUT} = V _{DD2} - 0.5V	—	—	70	kΩ
"0" Output Resistance	R _{OL}	—	SEGMENT COM1~3	V _{OUT} = 0.5V	—	—	70	kΩ
KEY Pull Up Resistance	R _{KEYH} (1)	—	RESET	V _{OUT} = V _{DD1} - 0.5V	—	—	25	kΩ
	R _{KEYH} (2)	—	K ₀ ~K ₉	V _{OUT} = V _{DD1} - 0.5V	—	—	14	kΩ
	R _{KEYH} (3)	—	K ₁₀ ~K ₁₃	V _{OUT} = 0V	120	—	800	kΩ
KEY Pull Down Resistance	R _{KEYL} (1)	—	RESET (1)	V _{OUT} = V _{DD1}	100	—	300	kΩ
	R _{KEYL} (2)	—	RESET (2)	V _{OUT} = V _{DD1}	18	—	300	kΩ
	R _{KEYL} (3)	—	K ₀ ~K ₉ (1)	V _{OUT} = 0.5V	—	—	50	kΩ
	R _{KEYL} (4)	—	K ₀ ~K ₉ (2)	V _{OUT} = V _{DD1}	72	—	170	kΩ
Oscillating (WAIT)	f _φ WAIT	—	—	V _{DD1} = 1.5V	5.4	9.0	15.5	kHz
Frequency (OPERATE)	f _φ OP	—	—	V _{DD1} = 1.5V	20.0	34	61.3	kHz
Frame Frequency	f _F	—	SEGMENT COM1~3	V _{DD1} = 1.5V	56.3	93.8	161.5	Hz

CHARACTERISTIC		SYMBOL	TEST CIRCUIT	PIN NAME	TEST CONDITION	MIN.	TYP.	MAX.	UNIT
Supply Current	1 (WAIT)	I _{DDWAIT}	—	—	V _{DD1} = 1.5V	—	—	3.3	μA
	2 (OPERATE)	I _{DDOP}	—	—	V _{DD1} = 1.2V	—	—	8.9	μA
	3 (OFF)	I _{DDOFF}	—	—	V _{DD1} = 1.5V	—	—	2.0	μA
Power Off Timer Times		T	—	—	V _{DD1} = 1.5V	429	600	1001	s

WAVEFORMS FOR DISPLAY

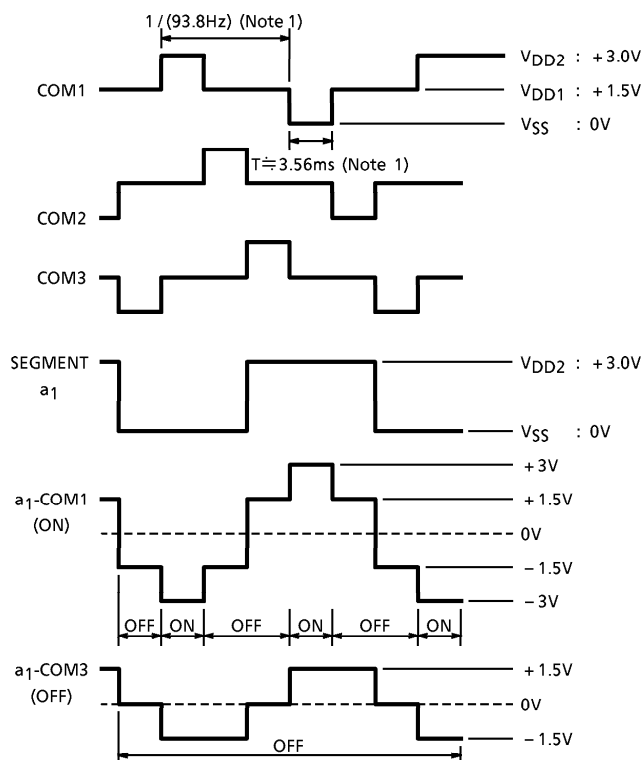

(Note 1) at $f_{\phi} = 9\text{kHz}$

PAD LOCATION TABLE

(μm)

NAME	X POINT	X POINT	NAME	X POINT	X POINT
COM3	-1757	-1680	B13	1757	1680
COM2	-1757	-1520	A13	1757	1520
COM1	-1757	-1360	C12	1757	1360
K13	-1757	-1200	B12	1757	1200
K12	-1757	-1040	A12	1757	1040
K11	-1757	-880	C11	1757	880
K10	-1757	-720	B11	1757	720
K9	-1757	-560	A11	1757	560
K8	-1757	-400	C10	1757	400
K7	-1757	-240	B10	1757	240
K6	-1757	-80	A10	1757	80
K5	-1757	80	C9	1757	-80
K4	-1757	240	B9	1757	-240
K3	-1757	400	A9	1757	-400
K2	-1757	560	C8	1757	-560
K1	-1757	720	B8	1757	-720
K0	-1757	880	A8	1757	-880
*(TS4)	-1757	1040	C7	1757	-1040
*(TS3)	-1757	1200	B7	1757	-1200
*(TS2)	-1757	1360	A7	1757	-1360
*(TS1)	-1757	1520	C6	1757	-1520
RESET	-1757	1680	B6	1757	-1680
V _G	-1388	1753	A6	1278	-1752
V _{DD1}	-1151	1753	C5	1118	-1752
V _{DD2}	-991	1753	B5	958	-1752
V _B	-831	1753	A5	798	-1752
V _A	-671	1753	C4	638	-1752
V _{SS}	-511	1753	B4	478	-1752
S4	-351	1753	A4	318	-1752
S3	-191	1753	C3	158	-1752
S2	-31	1753	B3	-2	-1752
S1	129	1753	A3	-162	-1752
B15	289	1753	C2	-322	-1752
A15	449	1753	B2	-482	-1752
C14	609	1753	C2	-642	-1752
B14	769	1753	C1	-802	-1752
A14	929	1753	B1	-962	-1752
C13	1089	1753	A1	-1122	-1752

*() Do not connect.

CHIP LAYOUT

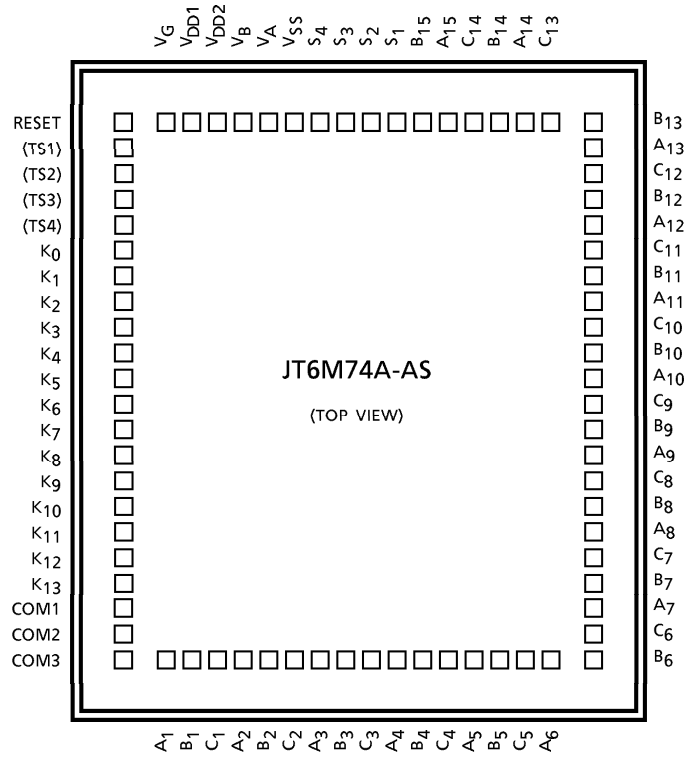

Chip size : 3.79×3.84 (mm)
 Chip thickness : 440 ± 30 (μm)
 Substrate : V_{SS}

PAD LAYOUT

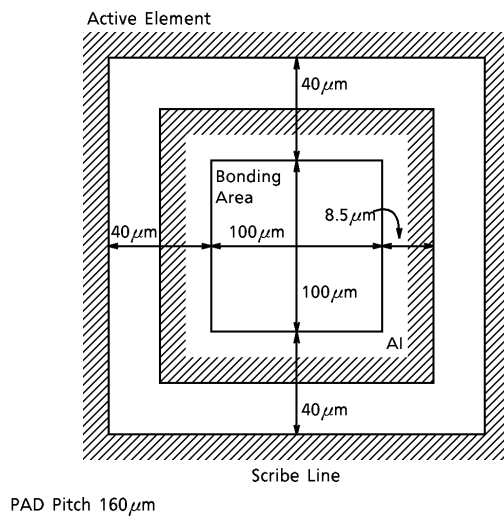

OUTLINE DRAWING
QFP80-P-1420-0.80A

Unit : mm

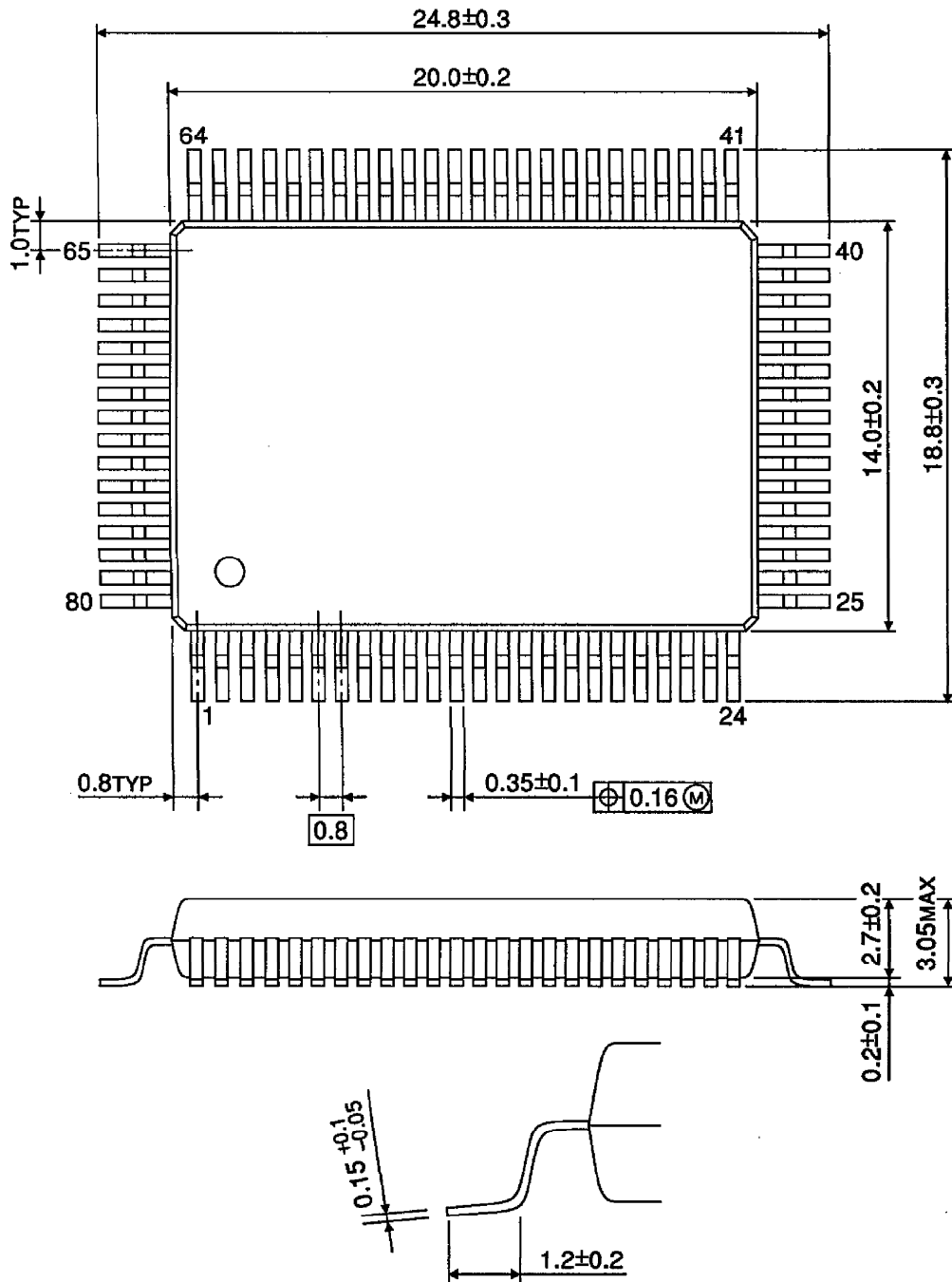

Weight : 1.52g (Typ.)

GENERAL SPECIFICATION FOR CALCULATOR LSI BARE CHIP**1. Purpose**

This is to specify the quality standard for the integrated circuit produced by TOSHIBA CORPORATION (hereinafter referred as to VENDOR) to be delivered to PURCHASER.

2. Definition

This specification applies only to the calculator LSI bare chip produced by VENDOR and purchased by PURCHASER and defined the general specification items.

3. Priority of specifications

When the discrepancies or questions happen to the specifications and instructions provided by VENDOR, the priority shall be ranked as follows.

- 1) Individual specification for the calculator LSI bare chip.
(Both PURCHASER and VENDOR are confirmed by the special sheets.)
- 2) General specifications for the calculator LSI bare chip.
- 3) Other related specifications and standards.

4. Characteristics

To be shown in the individual specification sheets.

The individual specification shall consist of the following 4 items in principle.

- 1) Rated specifications.
- 2) Electrical characteristics.
- 3) Pin configuration & mechanical dimensions.
- 4) Others.

5. Inspection of product for delivery**5.1 Inspection lot**

- a) Inspection lot shall consist of products produced by same material under same design, through same production process, and same facilities and assured same quality by same quality assurance method, and lot number shall be put on all trays to be able to trace the lot history.
- b) The quantity of products per Inspection lot shall consist of all the same VENDOR's lot number.

5.2 Sampling plan

Statistical sampling and inspection shall be in accordance with MIL-STD-105D single sampling plans for normal inspections, general inspection level II.

The acceptable quality level (AQL) shall be specified in following table :

TEST ITEM	AQL (%)
Electrical	2.5
Visual	4.0

5.3 Electrical criteria

Criteria of Electrical Characteristics are prescribed in Attachment-1.

5.4 Visual criteria

Visual Criteria are prescribed in Attachment-2.

6. Incoming inspection

6.1 General

- a) PURCHASER's incoming inspection should be done within 15 days after PURCHASER receives the quantity of products in principle.
- b) PURCHASER shall report the results of incoming inspection to VENDOR and provide VENDOR with detailed data in failure rate and items regarding VENDOR's lot number respectively, if VENDOR demands the report from PURCHASER.

6.2 Inspection procedure

PURCHASER should do his incoming inspection according to the following procedure.

- a) First : Visual inspection should be done.
- b) Next : Electrical and other inspection should be done under condition with bare chip before going into PURCHASER's process.

7. Treatment for defective lot and products

Regarding the defective lot and defective products which are found through PURCHASER's incoming inspection, PURCHASER can be returned to VENDOR with detailed description on failures concerned.

However, if VENDOR cannot receive the defective items within 30 days after PURCHASER's incoming inspection, VENDOR should be able to make no reference to the defective problem.

8. Packing and labeling

- a) Dice shall be placed in die tray with the top metalization facing up in order.
- b) In principle, a pile consists of 5 trays and several piles are packed in a package. These piles and packages are indicated with printed labels as shown below.

Date	
Name	
Lot No.	
Net	
TOSHIBA MADE IN JAPAN	

- c) PURCHASER shall return these packing materials to VENDOR on VENDOR's demand.

9. Storage criteria

Solid state chips, unlike packaged devices, are non-hermetic devices normally fragile and small in physical size, and therefore, require special handling considerations as follows :

- 9.1 Chips must be stored under proper conditions to insure that they are not subjected to a moist and/or contaminated atmosphere that alter their electrical, physical, or mechanical characteristics.
After the shipping container is opened, the chips must be stored under the following conditions :
 - A. Storage temperature, 40°C max.
 - B. Relative humidity, 50% max.
 - C. Clean, dust-free environment.
- 9.2 The user must exercise proper care when handling chips or wafers to prevent even the slightest physical damage to the chip.
- 9.3 During mounting and lead bounding of chips the user must use proper assembly techniques to obtain proper electrical, thermal, and mechanical performance.
- 9.4 After the chip has been mounted and bounded, any necessary procedure must be followed by the user to insure that these non-hermetic chips are not subjected to moist or contaminated atmosphere which might cause the development of electrical conductive paths across the relatively small insulating surfaces.
In addition, proper consideration must be given to the protection of these devices from other harmful environments which could conceivably adversely affect their proper performance.

10. Handling criteria

The user should find the following suggested precautions helpful in handling chips.

In any event, because of the extremely small size and fragile nature of chips, care should be taken in handling these devices.

10.1 Grounding

- a) Bonders, pellet pickup tools, table tops, trim and form tools, sealing equipment, and other equipment used in chip handling should be properly grounded.
- b) Operator should be properly grounded.

10.2 In-process handling

- a) Assemblies or subassemblies of chips should be transported and stored in conductive carriers.
- b) All external leads of the assemblies or subassemblies should be shorted together.

VISUAL INSPECTION CRITERIA

1. Visual inspection magnification shall be 40 × in principle.

2. Defects defined :

2.1 Thickness

See the technical data sheet.

2.2 Chip and crack

A die shall be rejected if :

- a) Any crack of chip extends greater than 35 μ m in length into the inside of the scribble line. (see Fig.1)

2.3 Metallization

A die shall be rejected if :

- a) More than 25% of the designed area of the metallization is missing at any bonding pad.
- b) There is a short or break which affects electrical characteristics in any lead pattern. (see Fig.2)

2.4 Glass protection coat

A die shall be rejected if :

- a) It exhibits glass protection coat which covers more than 25% of any active bonding pad.

2.5 Attached foreign material

A die shall be rejected if :

- a) A die is covered by stains or attached foreign material which size is more than 5 times as large as a bonding pad area.
- b) It exhibits residual ink, stains or attached foreign material which covers more than 20% of any active bonding pad. (see Fig.3)

2.6 Others

A die shall be rejected if :

- a) There have no evident probed impression on the bonding pads.
- b) A inked die, defective die, is intermized.

3. Limit samples should be fized, if necessary.

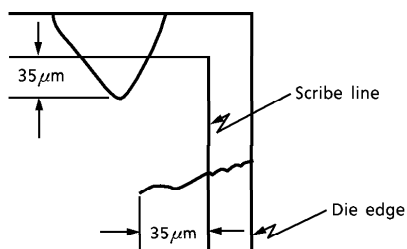

Fig.1

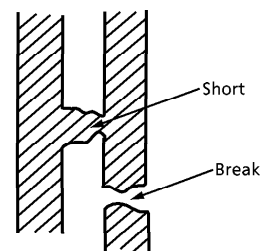

Fig.2 Lead pattern

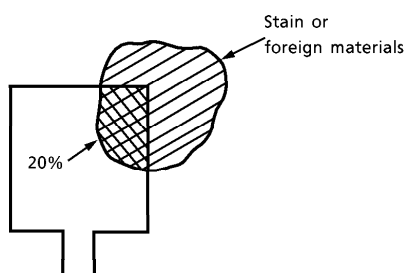
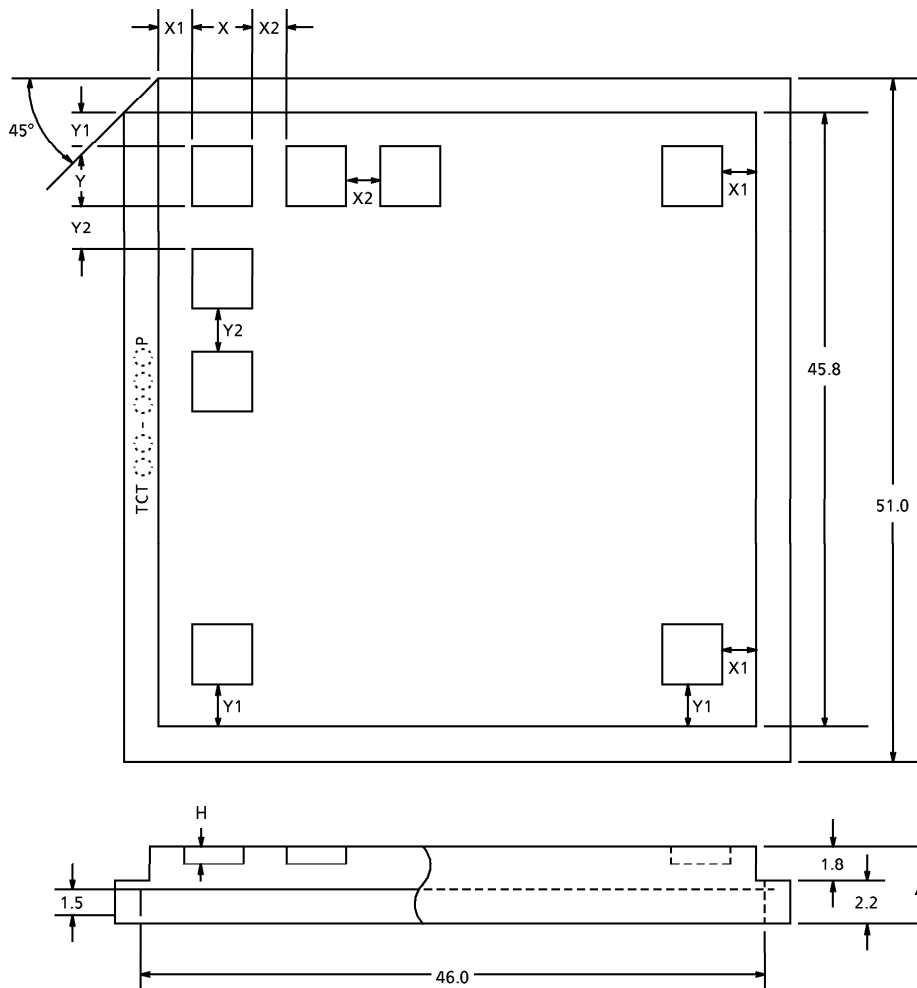

Fig.3

OUTSIDE DIMENSIONS OF CHIP TRAY



Unit : mm

CHIP NAME	TRAY NAME	X	Y	(H)	No. OF POCKETS	X1	X2	Y1	Y2
JT6M74A-AS	TCT45-060P	4.50	4.50	0.60	7 × 7 (49)	2.050	1.700	2.050	1.700

Tray material :

Carbon-containing polypropylene

PACKING METHOD-1

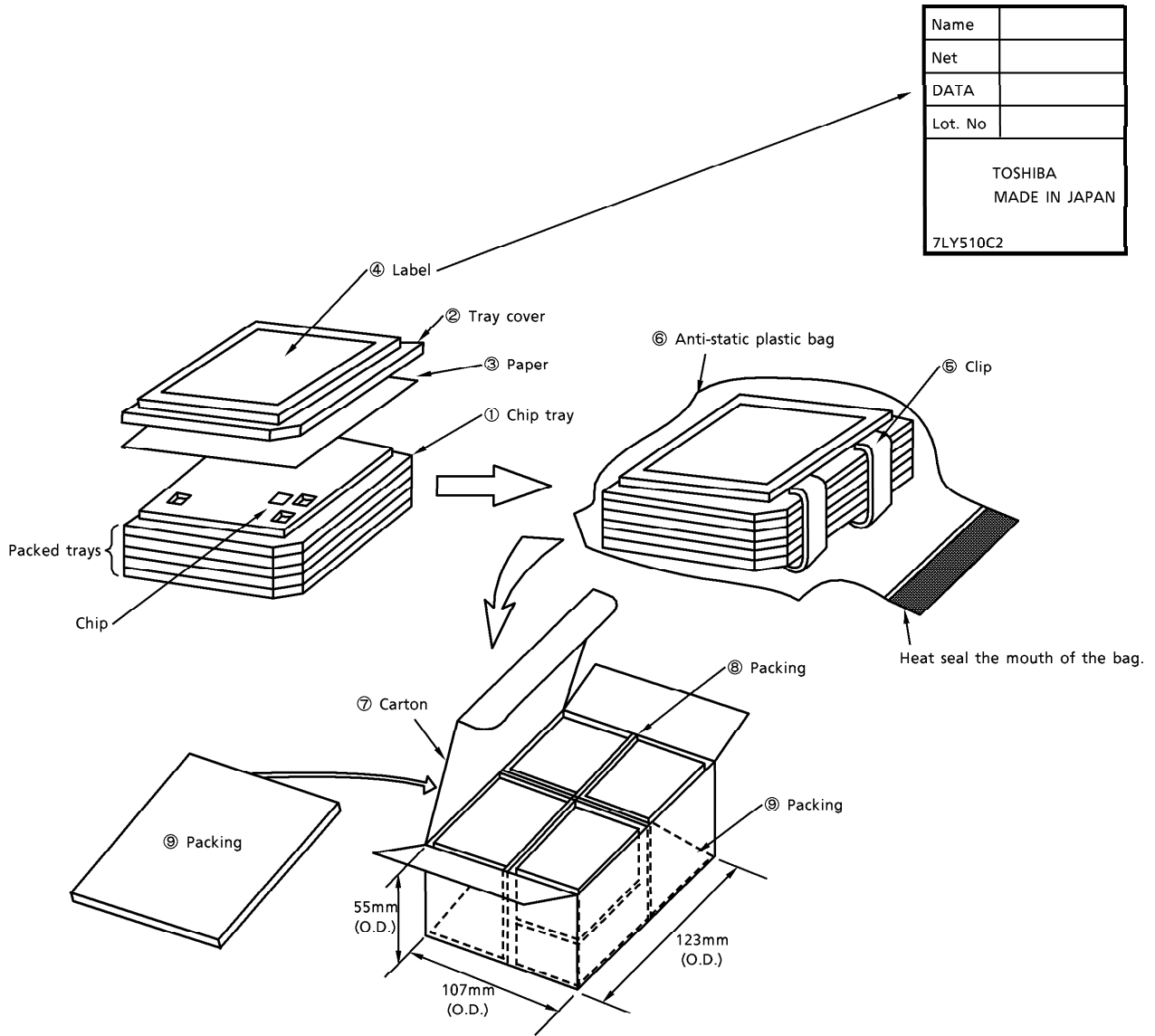

Name	
Net	
DATA	
Lot. No	
TOSHIBA MADE IN JAPAN	
7LY510C2	

Place eight bags of chip trays in each carton box ⑦. Lay one sheet of packing ⑨ (7UF44F) before closing the lid of the cart box. (See the diagram above.)
 Prepare packing ⑨ by cutting 7UF44F into halves and folding each in half as shown below ; use them as inner partitions.

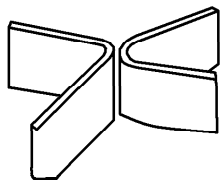

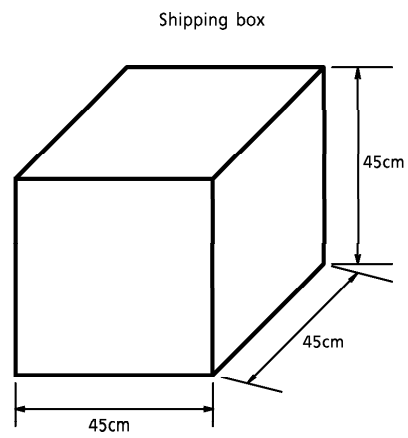
PACKING METHOD-2

- Inner box : Containing 20 boxes
- Weight : Approx. 15kg (including packing material)
- Material : Corrugated cardboard
- IC contents : $36 \times 5 \times 8 \times 20 = 28.8\text{kpcs}$.