

## Dual Output Flasher

### Description

The integrated circuit U2044B is used in relay controlled automotive flashers. With two output stages each side of the vehicle is controlled separately. A left and a right direction indicator input with only a small control current makes switch contacts for small loads possible.

The separate hazard warning input simplifies the construction of the hazard switch. Lamp outage is indicated by frequency doubling during direction mode. Thanks to the extreme low current consumption U2044B can be connected to the battery directly.

### Features

- Temperature and supply voltage compensated flashing frequency
- Frequency doubling indicates lamp outage
- Two relay driver outputs with high current-carrying capacity and low saturation voltage
- Minimum lamp load for flasher operation:  $\geq 1$  W
- Very low susceptibility to EMI
- Protection according to ISO/TR7637/1 level 4
- Extremely low current consumption  $< 10 \mu\text{A}$  (@switches open)
- Reverse polarity protection
- Three control inputs: left, right and hazard warning

### Ordering Information

Extended Type Number	Package	Remarks
U2044B	DIP14	
U2044B-FP	SO14	

### Pin Description

Pin	Symbol	Function
1	OSC	Oscillator
2	SIL	Start input left
3	SIR	Start input right
4	SIHW	Start input hazard warning
5	V <sub>S</sub>	V <sub>S</sub>
6	CR1	Control input relay 1
7	CR2	Control input relay 2
8	LD	Lamp failure detection
9	V <sub>S</sub>	V <sub>S</sub>
10	GND	IC ground
11	OR1	Output relay 1
12	V <sub>S</sub>	V <sub>S</sub>
13	OR2	Output relay 2
14	OSC	Oscillator

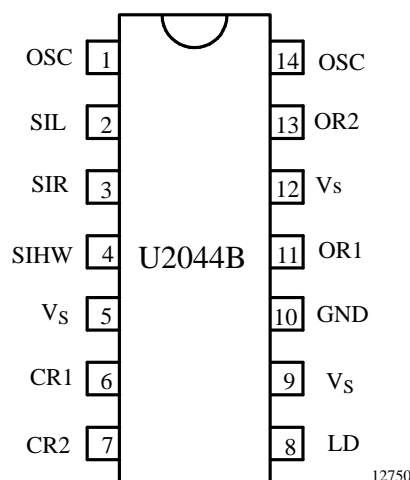

Figure 1. Pinning

## Block Diagram

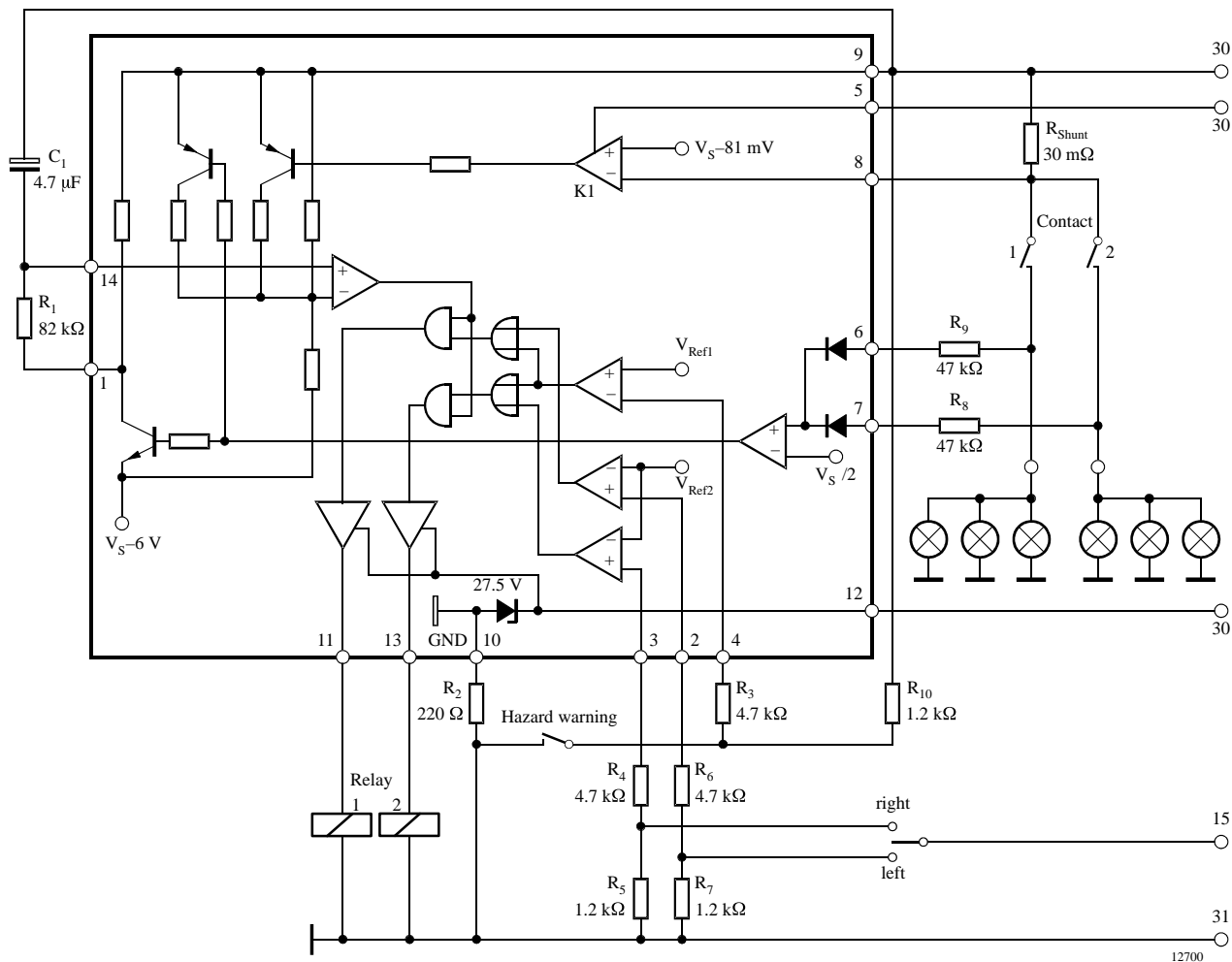

Figure 2. Application circuit  
 R<sub>2</sub> for protection against continuous reversed polarity: 1 Watt

## Functional Description

### Pin 1 and Pin 14, Oscillator

Flashing frequency,  $f_1$ , is determined by the  $R_1C_1$  components as follows (see figure 2):

$$f_1 \approx \frac{1}{R_1 \times C_1 \times 1.5} \text{ Hz}$$

where  $C_1 \leq 47 \mu\text{F}$   
 $R_1 = 6.8 \text{ k}\Omega$  to  $510 \text{ k}\Omega$

In the case of a lamp outage the oscillator frequency is switched to the lamp outage frequency  $f_2$  with  $f_2 \approx 2.2 \times f_1$ .

Duty cycle in normal flashing mode: 50%

Duty cycle in lamp outage mode (bright phase): 40%

### Pin 2 and Pin 3, Start input right and left

Flashing is disabled as long as the input comparator is tied to GND (pull-down resistor  $R_7$  or  $R_5$ ). The high side flasher switch "left" or "right" changes the comparator status and enables the output stage at Pin 11 or Pin 13.  $R_6$  and  $R_4$  are protection resistors for the input stage.

With an open flasher switch the current consumption is only  $I < 10 \mu\text{A}$ . The IC kept in stand-by mode until there is a voltage drop of  $V \approx 6.9 \text{ V}$  at the pull-down resistor.

Direction mode can only be activated when the ignition switch is in ON-position as shown in figure 2.

### Pin 4, Start input hazard warnig

In contrast to the direction switches, the hazard input is

a low-side type. The pull-up resistor  $R_{10}$  provides the off-state.  $R_3$  is a protection resistor for the input stage.

Hazard warning can be activated independent of the ignition switch position.

**Pin 5, Supply voltage sense**

This pin supplies the lamp outage comparator at Pin 8 and is externally connected to the battery (K1 30).

**Pin 6 and 7, Control input relay 1 and 2**

The feedback detects the bright phase and the dark phase and enables the oscillator.

**Pin 8, Lamp outage detection**

The lamp current is monitored via an external shunt resistor,  $R_{Shunt}$  and an internal comparator K1 with its reference voltage of typ. 81 mV ( $V_S = 12$  V). The outage of one lamp out of two lamps is detected according to the following calculation:

Nominal current of 1 lamp:  $21$  W / ( $V_S = 12$  V):

$$I_{lamp} = 1.75$$
 A

Nominal current of 2 lamps:  $2 \times 21$  W / ( $V_S = 12$  V):

$$I_{lamp} = 3.5$$
 A.

The detection threshold is recommended to be set in the middle of the current range:  $I_{outage} \approx 2.7$  A

Thus the shunt resistor is calculated as:

$$R_{Shunt} = V_T(K1) / I_{outage}$$

$$R_{Shunt} = 81 \text{ mV} / 2.7 \text{ A} = 30 \text{ m}\Omega.$$

Comparator K1's reference voltage is matched to the characteristics of filament lamps (see "control signal threshold" in the data part).

The combination of shunt resistor and resistance of wire harness prevents Pin 8 from a too high voltage in the case of shorted lamps.

**Pin 9, Supply voltage**

This pin supplies the oscillator, the comparators and the logic parts of the IC.

**Pin 10, GND**

The integrated circuit is protected against transients according to ISO-TR 7637-3 level 3 via resistor  $R_2$  to ground (-31). An integrated protection circuit together with external resistors  $R_2, R_3, R_4, R_6, R_8$  and  $R_9$  limits the current pulses in the IC. Against reversed battery the IC is also protected.

**Pin 11 and 13, Control output relay 1 and 2**

The relay control outputs are high-side driver with a low saturation voltage and capable to drive a typical automotive relay with a coil resistance of 60  $\Omega$ .

**Pin 12, Supply voltage power**

This pin supplies the relay drivers connected directly to the battery (K1 30). It is internally clamped by a 27-V Z-diode.

## Absolute Maximum Ratings

Reference point ground (terminal 31), with external circuitry.

Parameters	Symbol	Value	Unit
Supply voltage, 1 min Pins 5, 9, 12	$V_S$	24	V
Junction temperature	$T_j$	150	$^{\circ}\text{C}$
Storage temperature range	$T_{stg}$	-55 to +150	$^{\circ}\text{C}$
Ambient temperature range	$T_{amb}$	-40 to +100	$^{\circ}\text{C}$

## Thermal Resistance

Parameters	Symbol	Value	Unit
Junction ambient DIP14	$R_{thJA}$	90	K/W
SO14	$R_{thJA}$	120	K/W

## Electrical Characteristics

Typical values under normal operation in application circuit figure 1,  $V_S (+30) = 12\text{ V}$ .  
Reference point ground (-31),  $T_{\text{amb}} = 25^\circ\text{C}$ , unless otherwise specified.

Parameters	Test Conditions / Pins	Symbol	Min.	Typ.	Max.	Unit
Supply voltage range	Pins 5, 9, 12	$V_S$	8		18	V
Supply current, switches open	Pins 5, 9, 12	$I_S$			10	$\mu\text{A}$
Output current for relay driver	Pins 11, 13	$I_O$			300	mA
Saturation voltage	$R_L = 82\ \Omega$ Pins 11, 13 $V_S = 8\text{ V}$ $V_S = 12\text{ V}$	$V_O$			1.0 1.2	V V
Relay coil resistance		$R_L$	60			$\Omega$
Relay output, reverse current	Pins 11, 13	$I_O$			0.1	mA
Start delay (first bright phase)		$t_{\text{ON}}$			10	ms
Control signal threshold	$V_S = 9\text{ V}$ Pin 8 $V_S = 13.5\text{ V}$ $V_S = 16\text{ V}$	$V_S$		70.6 85.0 93.0		mV mV mV
Tolerance of control signal threshold	$V_S = 9\text{ to }16\text{ V}$ , Pin 8 $T_{\text{amb}} = -40\text{ to }+100^\circ\text{C}$		-6		+6	%
Temperature coefficient of control signal threshold	$V_S = 13.5\text{ V}$ Pin 8	$T_K$		10		$\mu\text{V/K}$
Clamping voltage	$T_{\text{amb}} = -40\text{ to }+100^\circ\text{C}$	$V_{12}$	25.0	27.5	30.0	V
Relay output overvoltage detection (relay disabled)	$T_{\text{amb}} = -40\text{ to }+100^\circ\text{C}$	$V_{12}$	18	20	22	V

## Tolerances

$V_S = 9\text{ to }18\text{ V}$ ,  $T_{\text{amb}} = -40\text{ to }+100^\circ\text{C}$

Parameters	Test Conditions / Pins	Symbol	Min.	Typ.	Max.	Unit
Frequency determining resistor		$R_1$	6.8		510	$\text{k}\Omega$
Frequency determining capacitor		$C_1$			47	$\mu\text{F}$
Frequency tolerance (normal flashing basic frequency $f_1$ not including the tolerance of the external components $R_1$ and $C_1$ )		$\Delta f_1$	-5		+5	%
Bright period (basic frequency $f_1$ )		$\Delta F_1$	47		53	%
Bright period (control frequency $f_2$ )		$\Delta f_2$	37		45	%
Frequency increase (lamp failure)		$f_2$	$2.15 \times f_1$		$2.3 \times f_1$	Hz
Lamp load		$P_L$	1			W

**Package Information**

Package DIP14

Dimensions in mm

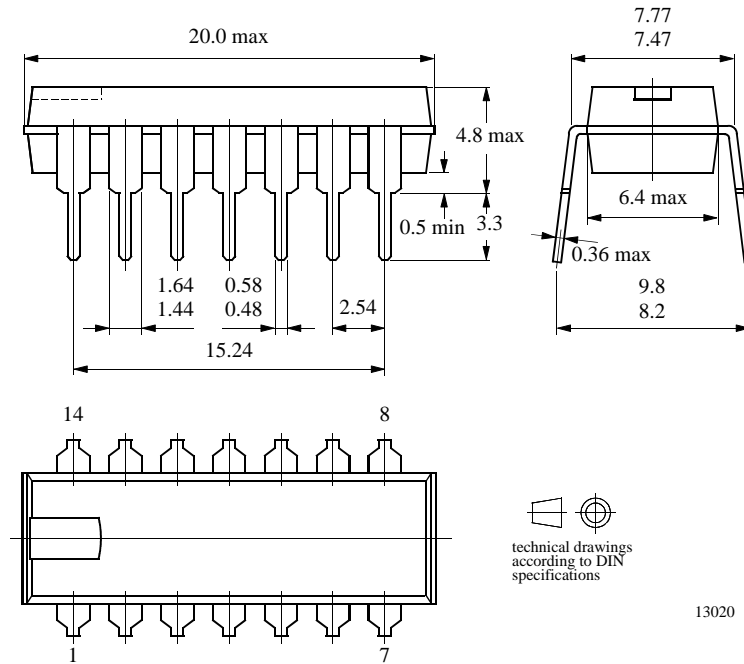

Package SO14

Dimensions in mm

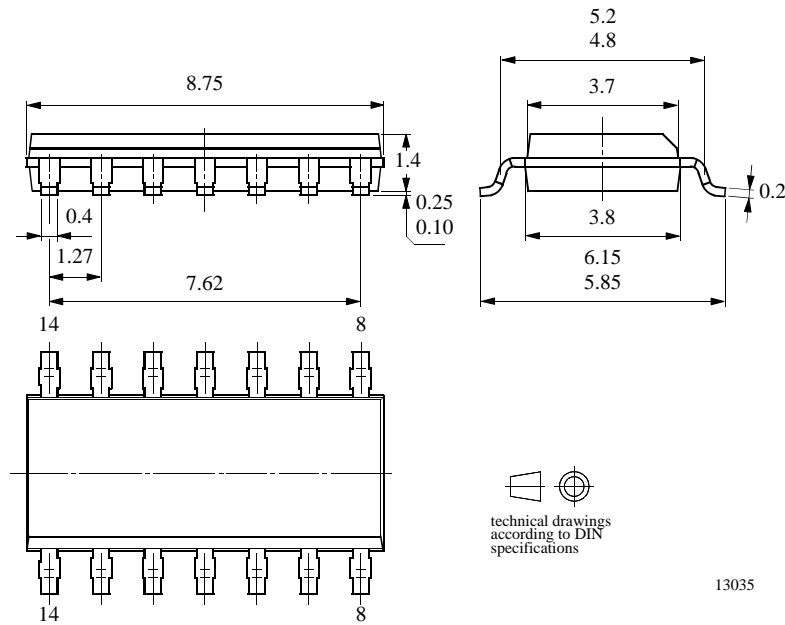

## Ozone Depleting Substances Policy Statement

It is the policy of **TEMIC TELEFUNKEN microelectronic GmbH** to

1. Meet all present and future national and international statutory requirements.
2. Regularly and continuously improve the performance of our products, processes, distribution and operating systems with respect to their impact on the health and safety of our employees and the public, as well as their impact on the environment.

It is particular concern to control or eliminate releases of those substances into the atmosphere which are known as ozone depleting substances (ODSs).

The Montreal Protocol (1987) and its London Amendments (1990) intend to severely restrict the use of ODSs and forbid their use within the next ten years. Various national and international initiatives are pressing for an earlier ban on these substances.

**TEMIC TELEFUNKEN microelectronic GmbH** semiconductor division has been able to use its policy of continuous improvements to eliminate the use of ODSs listed in the following documents.

1. Annex A, B and list of transitional substances of the Montreal Protocol and the London Amendments respectively
2. Class I and II ozone depleting substances in the Clean Air Act Amendments of 1990 by the Environmental Protection Agency (EPA) in the USA
3. Council Decision 88/540/EEC and 91/690/EEC Annex A, B and C (transitional substances) respectively.

**TEMIC** can certify that our semiconductors are not manufactured with ozone depleting substances and do not contain such substances.

**We reserve the right to make changes to improve technical design and may do so without further notice.**

Parameters can vary in different applications. All operating parameters must be validated for each customer application by the customer. Should the buyer use TEMIC products for any unintended or unauthorized application, the buyer shall indemnify TEMIC against all claims, costs, damages, and expenses, arising out of, directly or indirectly, any claim of personal damage, injury or death associated with such unintended or unauthorized use.

TEMIC TELEFUNKEN microelectronic GmbH, P.O.B. 3535, D-74025 Heilbronn, Germany  
Telephone: 49 (0)7131 67 2831, Fax number: 49 (0)7131 67 2423