

TOSHIBA BIPOLAR LINEAR INTEGRATED CIRCUIT SILICON MONOLITHIC

TA2099N, TA2099F

AM / FM IF + FM STEREO DETECTOR (FOR DIGITAL TUNING SYSTEM)

TA2099N and TA2099F are the AM / FM IF + FM Stereo Detector IC, which is designed for DTS Radios. This is included many functions and this can be used for Digital Tuning System with IF Counter.

FEATURES

- Suitable for combination with Digital Tuning System which has IF Counter.
 - AM / FM IF Count Output for IF Counter
 - Built-in Mute Circuit for IF Count Output
 - Built-in Mute Circuit for Audio Output
 - FM IF Count Output Sensitivity is adjustable by External Resistance
- Built-in FM Narrow Detector Circuit
 - Band Width is adjustable by External Resistance
- FM LED ON Sensitivity is adjustable by External Resistance
- Built-in Resonance Circuit for FM Stereo Detector VCO
- Built-in FM Blender Control Circuit
- Built-in Anti-birdie Circuit
- Built-in AM Local OSC Buffer Output Circuit
- Operating Supply Voltage Range : $V_{CC} = 4.0 \sim 9 \text{ V}$ ($T_a = 25^\circ\text{C}$)

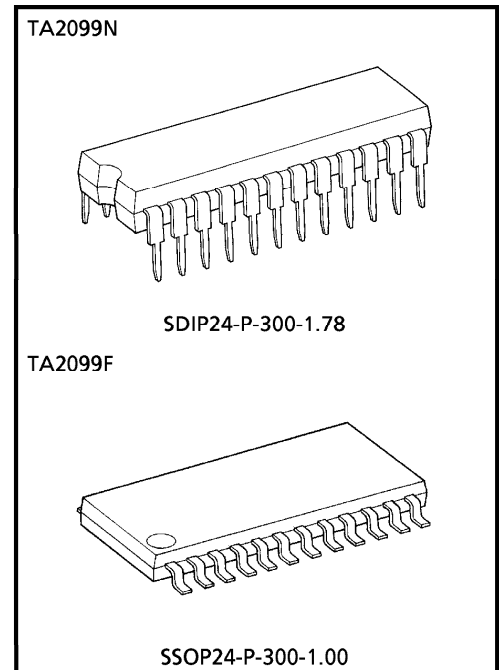

Weight
 SDIP24-P-300-1.78 : 1.2 g (Typ.)
 SSOP24-P-300-1.00 : 0.31 g (Typ.)

980910EBA1

- TOSHIBA is continually working to improve the quality and the reliability of its products. Nevertheless, semiconductor devices in general can malfunction or fail due to their inherent electrical sensitivity and vulnerability to physical stress. It is the responsibility of the buyer, when utilizing TOSHIBA products, to observe standards of safety, and to avoid situations in which a malfunction or failure of a TOSHIBA product could cause loss of human life, bodily injury or damage to property. In developing your designs, please ensure that TOSHIBA products are used within specified operating ranges as set forth in the most recent products specifications. Also, please keep in mind the precautions and conditions set forth in the TOSHIBA Semiconductor Reliability Handbook.
- The products described in this document are subject to the foreign exchange and foreign trade laws.
- The information contained herein is presented only as a guide for the applications of our products. No responsibility is assumed by TOSHIBA CORPORATION for any infringements of intellectual property or other rights of the third parties which may result from its use. No license is granted by implication or otherwise under any intellectual property or other rights of TOSHIBA CORPORATION or others.
- The information contained herein is subject to change without notice.

BLOCK DIAGRAM

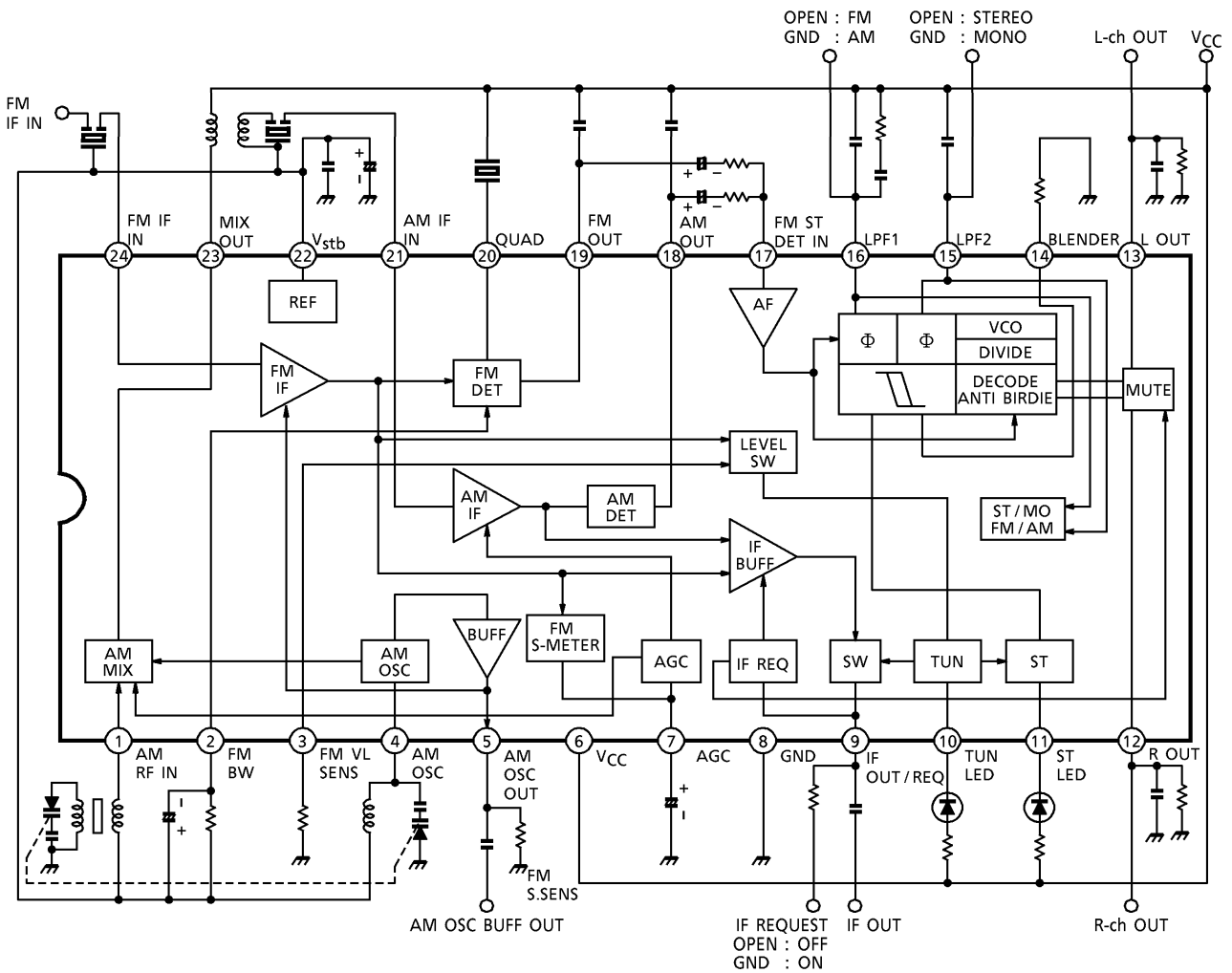

* The Toshiba evaluation board uses the bar antenna shown below.

USE	f	L	Q ₀	NUMBER OF WINDINGS		WINDING THICKNESS (mm)	NOTE
				1-2	3-4		
MW ANT	796 kHz	220 μH	150~220	59	17	3 / 0.07 μATC	Mitsumi L-3107

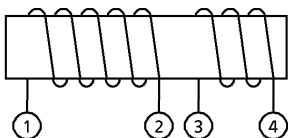

TERMINAL EXPLANATION (Terminal voltage shows the typical value at $T_a = 25^\circ\text{C}$, $V_{CC} = 5\text{V}$, $SW_3 : \text{OFF}$, $SW_9 : \text{GND}$ and non-signal test circuit)

PIN No.	CHARACTERISTIC	INTERNAL CIRCUIT	DC VOLTAGE (V)	
			FM	AM
1	AM RF IN		2.0	2.0
2	FM BW ● FM Band Width Adjust Terminal		2.0	2.0
3	FM VL SENS ● FM LED ON Sensitivity Adjust Terminal		0.1	0.1

PIN No.	CHARACTERISTIC	INTERNAL CIRCUIT	DC VOLTAGE (V)	
			FM	AM
4	AM OSC		2.0	2.0
5	AM OSC OUT / FM S.SENS ● AM OSC Buff Output Terminal ● FM IF Count Output Sensitivity Adjust Terminal		1.3	1.3
6	VCC	—	5.0	5.0
7	AGC (FM S-METER)		0.2	1.3
8	GND	—	0	0

PIN No.	CHARACTERISTIC	INTERNAL CIRCUIT	DC VOLTAGE (V)	
			FM	AM
9	IF OUT / REQ ● IF Count Output Terminal ● IF Count Output / FM ST DET Mute Circuit Control Terminal SW ₃ : GND → ON SW ₃ : Open → OFF		—	—
10	TUN LED		—	—
11	ST LED		—	—
12	R OUT		1.2	1.2
13	L OUT			

PIN No.	CHARACTERISTIC	INTERNAL CIRCUIT	DC VOLTAGE (V)	
			FM	AM
14	<p>BLENDER</p> <ul style="list-style-type: none"> ● FM Blender Control Adjust Terminal 		0.3	0.3
15	<p>LPF2</p> <ul style="list-style-type: none"> ● LPF Terminal for Synchronous Detector ● VCO Stop Terminal V15 = GND → VCO Stop (Monaural) V15 = Open → VCO Run (Stereo) 		3.5	1.4
16	<p>LPF1</p> <ul style="list-style-type: none"> ● LPF Terminal for Phase Detector ● Bias Terminal for AM/FM Switch Circuit V16 = GND → AM V16 = Open → FM 		3.5	0
17	<p>FM ST DET IN</p>		1.2	1.2

PIN No.	CHARACTERISTIC	INTERNAL CIRCUIT	DC VOLTAGE (V)	
			FM	AM
18	AM DET OUT		0	1.3
19	FM DET OUT		1.4	2.0
20	QUAD		1.8	2.3
21	AM IF IN		2.0	2.0

PIN No.	CHARACTERISTIC	INTERNAL CIRCUIT	DC VOLTAGE (V)	
			FM	AM
22	V _{stb}		2.0	2.0
23	AM MIX OUT		5.0	5.0
24	FM IF IN		2.0	2.0

OPERATIONS IN DETAIL

1. Application circuit when using a coil demodulator

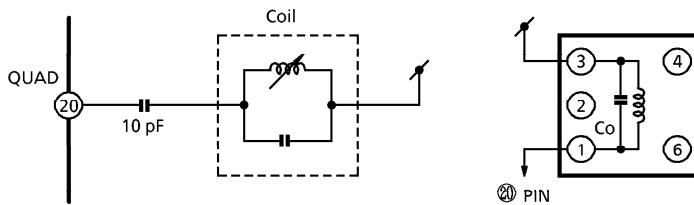

COIL DATA

	f (Hz)	C ₀ (pF)	Q ₀	NUMBER OF WIRE TURNS			WIRE (mm φ)	REMARKS
				1-2	2-3	1-3		
FM DET	10.7 M	51	45			30	0.08 φ 2UEW	TOKO Co., Ltd. 600BEAS-10018Z

2. Center meter adjustment

It can be switch ΔV, pin voltages between 2-pin and 22-pin (V_{stb}) for narrow band detection or both side of R_{2pin} voltages, to 0V to adjust a coil. This adjustment made possible to set the voltage to center voltage and the midpoint of lighting LED band to the frequency (10.7 MHz).

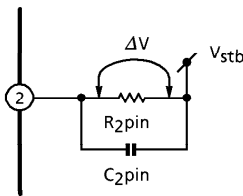

Assembled C_{2pin} and R_{2pin} compose HPF.

$$f_c = \frac{1}{2\pi RC}$$

Select R_{2pin} in accordance with specifications for narrow band detection and set C_{2pin} by following that of resistance. Please take these into account.

3. Function Switching

(1) FM → AM switching

Pin 16 : Connect the LPF1 pin to GND. (Adjust using external parts so that the voltage does not exceed 0.6 V.)

(2) STEREO → MONO switching

Pin 15 : Connect the LPF2 pin to GND. (Adjust using external parts so that the voltage does not exceed 0.6 V.)

Note : When STEREO/FM is selected, the multiplex VCO frequency changes due to 0.1 μA flow.

(3) IF OUT → ON switching

Pin 9 : When the voltage on the IF OUT/REQ pin is set to 1.3 V or below (V_{stb} (2 V) – V_{be} (0.7 V)) and about 500 μA current flows, switch to ON. Toshiba recommends a load of 2.2 kΩ.

4. External Change Function

(1) Narrowband detector : When the FM IF input signal is off-center, 10.7 MHz, by a few kHz, the detector turns TUN-LED OFF.

Pin 2 : Adjusts bandwidth using the resistor of the FM BW pin. In combination with the C2 pin, the R2 pin configures an HPF. The smaller the pin 2 capacitance, the higher the HPF cutoff. Note that when low-frequency sound is input, although tuning is maintained, the detector may turn TUN-LED OFF.

(2) LED ON sensitivity adjustment

Pin 3 : Uses the FM VL SENS pin resistor value to change the ON sensitivity of TUN-LED.

(3) IF counter output sensitivity adjustment

Pin 5 : Uses the FM S. SENS pin resistor value to change the sensitivity of the IF count output at IF count ON.

* : For the LED on sensitivity, (2) and (3) are linked.

At IF count ON (connect resistor for pin 9 to GND), the internal current depending on the pin 5 resistor value changes the IF amp gain, the S meter startup, and the IF input level (sensitivity). The LED ON sensitivity turns the LED ON by comparing the voltage which depends on the pin 3 resistor value with the S meter voltage. The change in S meter startup (sensitivity) at IF count ON causes the LED ON sensitivity set at IF count OFF to change. Therefore, confirm the LED ON sensitivity according to the seek operation specification.

(4) Blender control

Pin 14 : Changes the MPX L and R signal separation according to the input level set by the resistance.

5. Others

(1) Vstb

Pin 22 : Set to 2 V internally.

(2) QUAD

Pin 20 : Supports both a ceramic discriminator and a detector coil for QUAD. See 1, in Description of Operation.

Note that when a detector coil is used, S/N and the skew ratio deteriorates.

(3) L, R output

Pins 12 and 13 : L-OUT and R-OUT pins are used for current output. The external resistor is set to output impedance. This is specified when the load is 5.1 k Ω and 0.01 μ F.

(4) AGC

Pin 7 : Also used as the FM S meter.

MAXIMUM RATINGS (Ta = 25°C)

CHARACTERISTIC		SYMBOL	RATING	UNIT
Supply Voltage		V _{CC}	14	V
LED Current		I _{LED}	10	mA
LED Voltage		V _{LED}	14	V
Power Dissipation	TA2099N	P _D (Note)	1200	mW
	TA2099F		400	
Operating Temperature		T _{opr}	- 25~75	°C
Storage Temperature		T _{stg}	- 55~150	°C

(Note) : Derated above 25°C in the proportion of 9.6 mW / 1°C.

ELECTRICAL CHARACTERISTICS

Unless otherwise specified, Ta = 25°C, V_{CC1} = 5 V, SW₃ = OFF

FM IF : f = 10.7 MHz, Δf = ±22.5 kHz, f_m = 1 kHz

AM : f = 1 MHz, MOD = 30%, f_m = 1 kHz

FM ST DET : f_m = 1 kHz

CHARACTERISTIC		SYMBOL	TEST CIR-CUIT	TEST CONDITION	MIN.	TYP.	MAX.	UNIT	
Supply Current		I _{CC} (FM)	1	FM mode, V _{in} = 0	—	17	23	mA	
		I _{CC} (AM)	1	AM mode, V _{in} = 0	—	14	20		
FM IF	Input Limiting Voltage	V _{in} (lim)	1	-3 dB limiting point	37	41	45	dB _μ V EMF	
	Recovered Output Voltage	V _{OD} (FM)	1	V _{in} = 80 dB _μ V EMF	75	100	125	mV _{rms}	
	Signal to noise Ratio	S / N (FM)	1	V _{in} = 80 dB _μ V EMF	—	71	—	dB	
	Total Harmonic Distortion	THD (FM)	1	V _{in} = 80 dB _μ V EMF	—	0.1	—	%	
	AM Rejection Ratio	AMR	1	V _{in} = 80 dB _μ V EMF	—	55	—	dB	
	LED ON Sensitivity	V _L (FM)	1	I _L = 1 mA	SW ₁ : 0 Ω	—	41	—	dB _μ V EMF
					SW ₁ : 1.2 kΩ	41	46	51	
					SW ₁ : 3.3 kΩ	—	54	—	
IF Count Output Voltage	V _{IF} (FM)	1	SW ₃ : ON, V _{in} = 80 dB _μ V EMF	240	290	—	mV _{p-p}		
IF Count Output Sensitivity	I _{Fsens} (FM)	1	SW ₃ : ON	SW ₂ : 2.2 kΩ	—	58	—	dB _μ V EMF	
				SW ₂ : 3.3 kΩ	47	53	59		
				SW ₂ : 4.7 kΩ	—	50	—		
AM	Gain	G _V	1	V _{in} = 23 dB _μ V EMF	28	50	82	mV _{rms}	
	Recovered Output Voltage	V _{OD} (AM)	1	V _{in} = 60 dB _μ V EMF	70	100	130	mV _{rms}	
	Signal to Noise Ratio	S / N (AM)	1	V _{in} = 60 dB _μ V EMF	—	45	—	dB	
	Total Harmonic Distortion	THD (AM)	1	V _{in} = 60 dB _μ V EMF	—	0.5	—	%	
	LED ON Sensitivity	V _L (AM)	1	I _L = 1 mA	21	26	31	dB _μ V EMF	
	Local OSC Buffer Output Voltage	V _{OSC} (AM)	1	f _{OSC} = 1.45 MHz	350	480	—	mV _{p-p}	
			2	f _{OSC} = 27 MHz	—	480	—		
	IF Count Output Voltage	V _{IF} (AM)	1	SW ₃ : ON, V _{in} = 60 dB _μ V EMF	250	370	—	mV _{p-p}	
IF Count Output Sensitivity	I _{Fsens} (AM)	1	SW ₃ : ON	—	26	—	dB _μ V EMF		

CHARACTERISTIC		SYMBOL	TEST CIR-CUIT	TEST CONDITION	MIN.	TYP.	MAX.	UNIT	
FM ST DET	Max. Composite Input Voltage	V_{in} (MAX) (STEREO)	1	L + R = 90%, P = 10% THD = 3%, SW ₈ → LPF : ON	—	800	—	mV _{rms}	
	Separation	Sep	1	L + R = 180 mV _{rms} P = 20 mV _{rms}	f_m = 100 Hz	—	45	—	dB
					f_m = 1 kHz	35	45	—	
					f_m = 10 kHz	—	45	—	
	Total Harmonic Distortion	Mono	THD (MONO)	1	SW ₈ → LPF : ON V_{in} = 200 mV _{rms} (MONO)	—	0.05	—	%
		Stereo	THD (STEREO)		L + R = 180 mV _{rms} , P = 20 mV _{rms} SW ₈ → LPF : ON	—	0.05	—	
	Voltage Gain		G_V (ST)	1	V_{in} = 200 mV _{rms} (MONO)	-2	-0.6	1	dB
	Channel Balance		C.B.	1	V_{in} = 200 mV _{rms} (MONO)	-1.5	0	1.5	dB
	Stereo LED Sensitivity	ON	V_L (ON)	1	Pilot input	—	10	16	mV _{rms}
		OFF	V_L (OFF)			4	8	—	
Stereo LED Hysteresis		V_H	1	to LED turn-off form LED turn-on	—	2	—	mV _{rms}	
Capture Range		C.R.	1	P = 20 mV _{rms}	—	± 4.5	—	%	
Signal to Noise Ratio		S / N (ST)	1	V_{in} = 200 mV _{rms} (MONO)	—	80	—	dB	
VCO Frequency		$f_{vco} / 12$	1	Specified when SW ₄ = ON, MPX VCO / 12	-300	19 k	+300	Hz	

FM MONO

VOD, Vno, THD, AMR - Vin

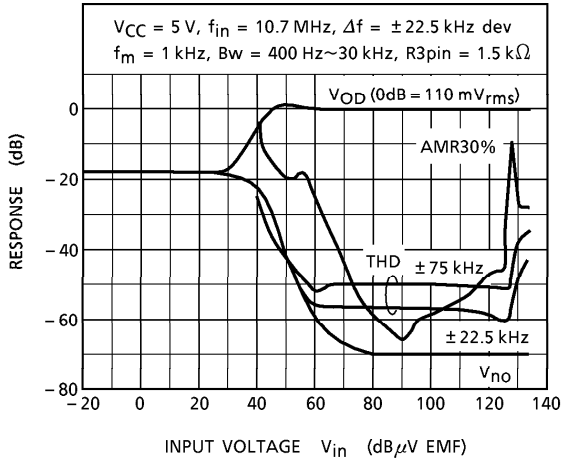

FM ST (Main)

VOD, Vno - Vin

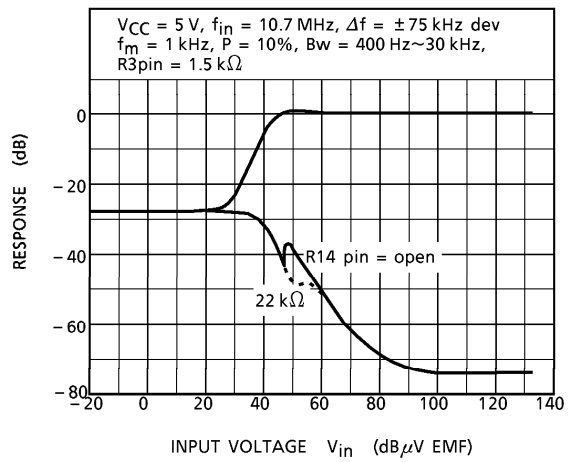

FM

VOD, THD - Δf

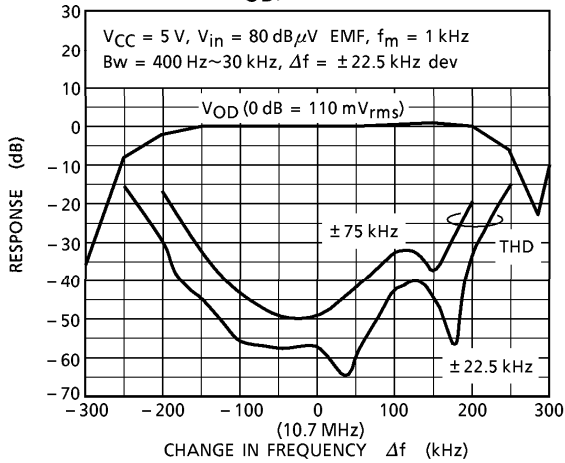

FM

VOD, AMR, S/N, THD - VCC

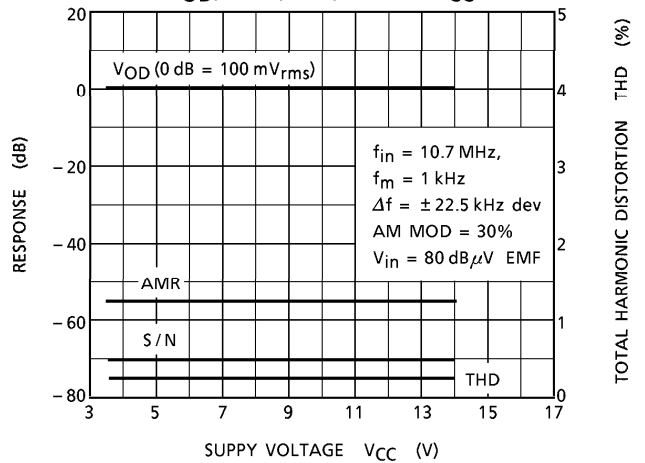

V_L ON - R₃ pin

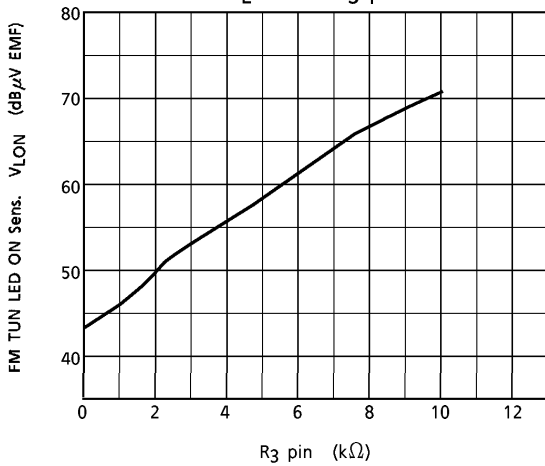

IF sens - R₅ pin

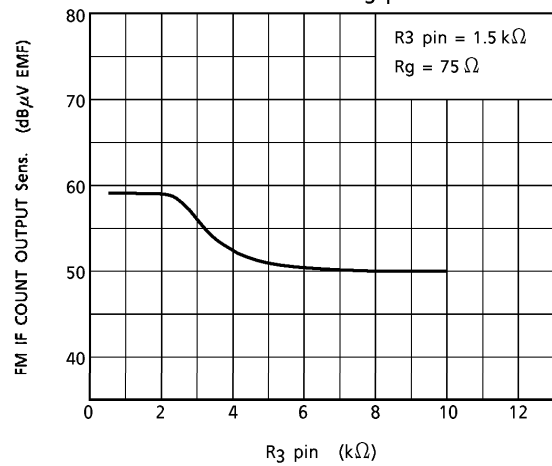

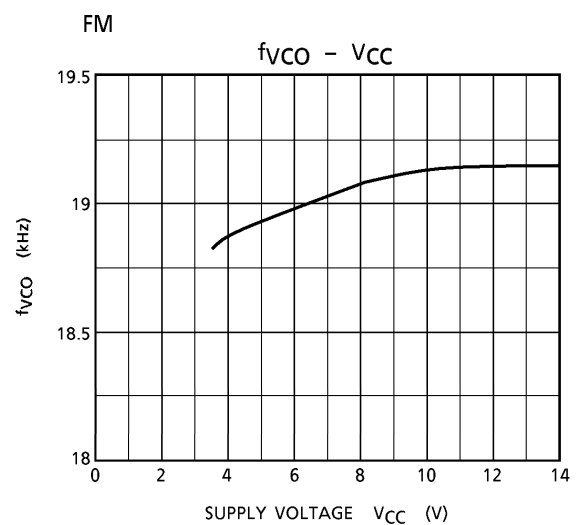
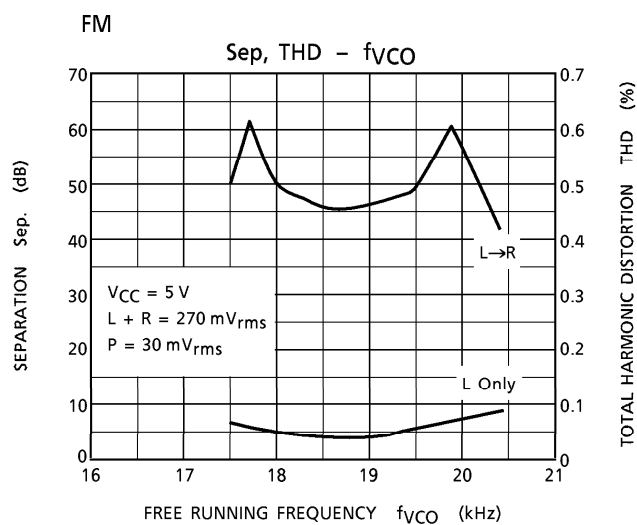
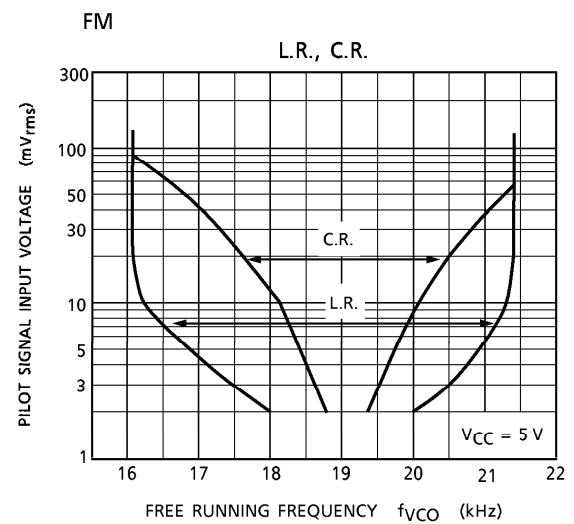
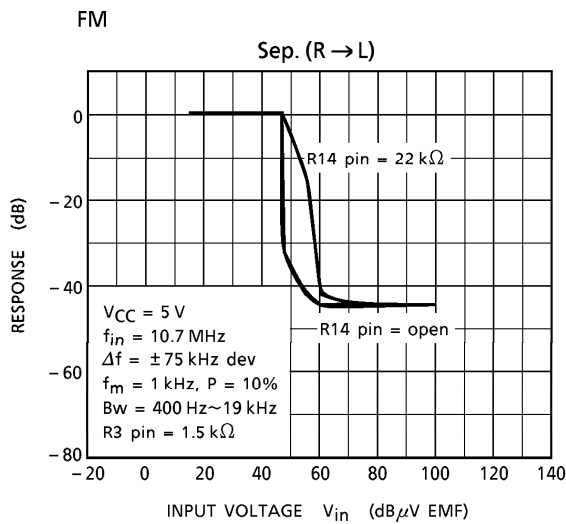
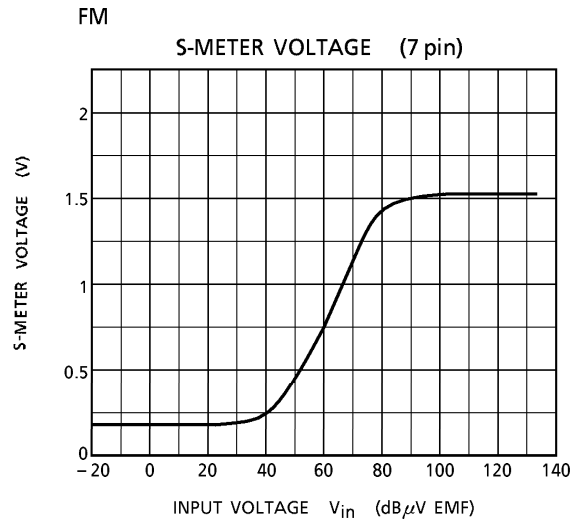
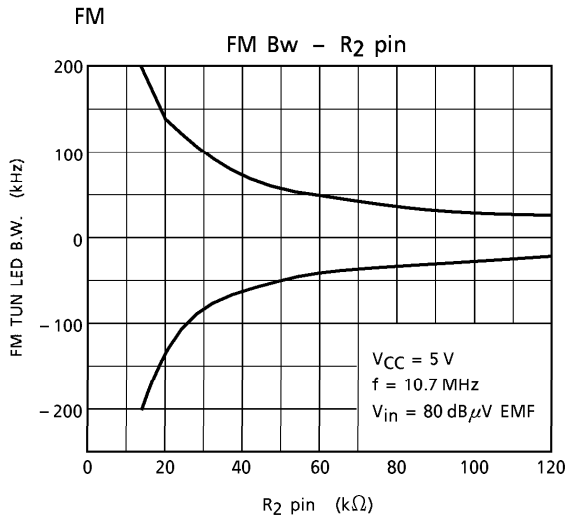

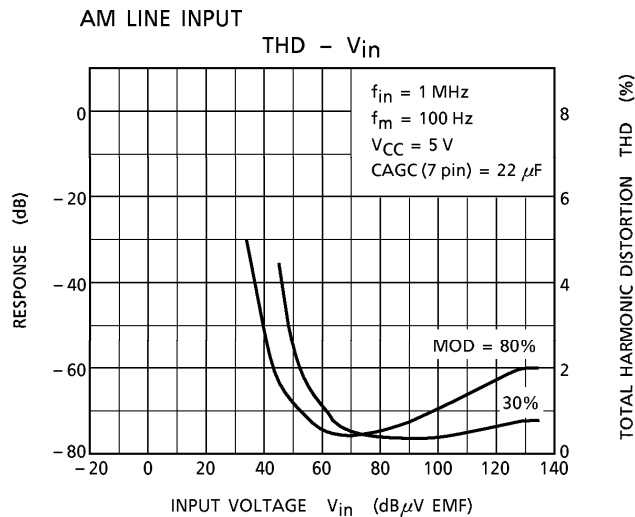
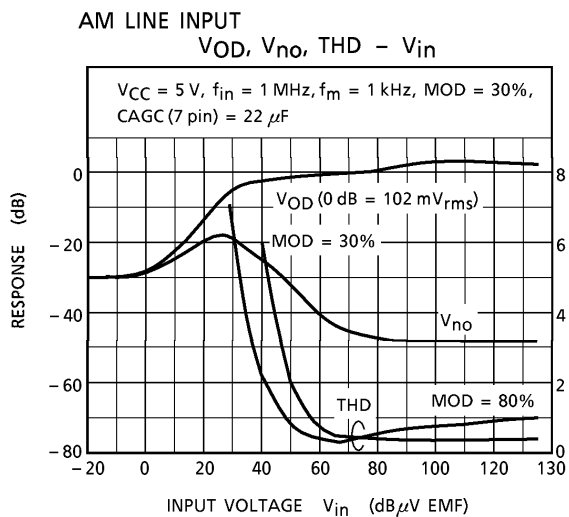
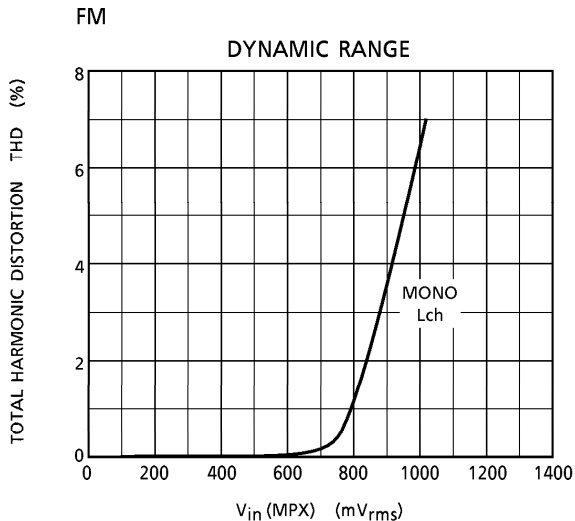
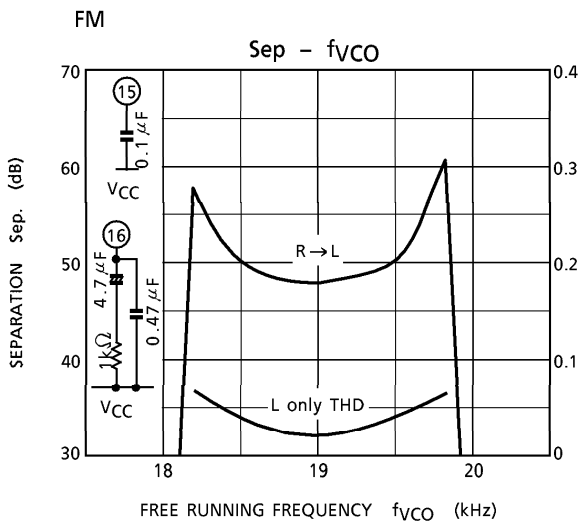

OUTLINE DRAWING
SDIP24-P-300-1.78

Unit : mm

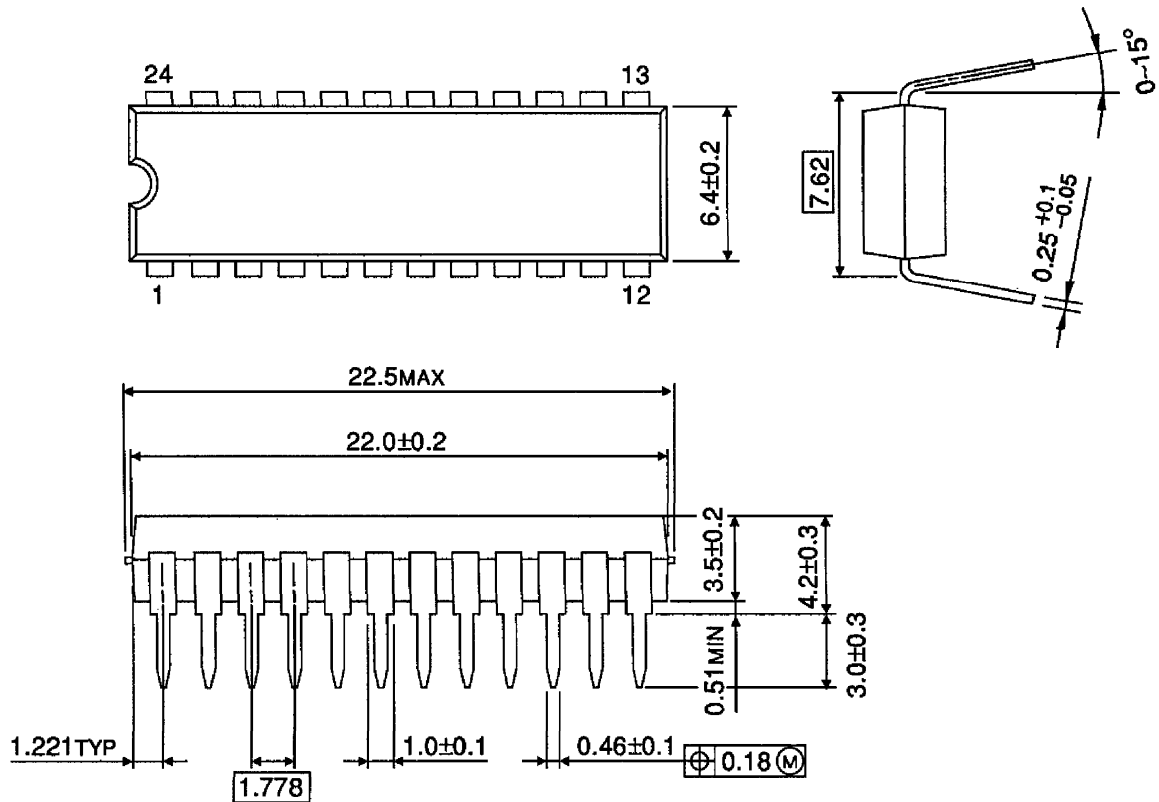

Weight : 1.2 g (Typ.)

OUTLINE DRAWING
SSOP24-P-300-1.00

Unit : mm

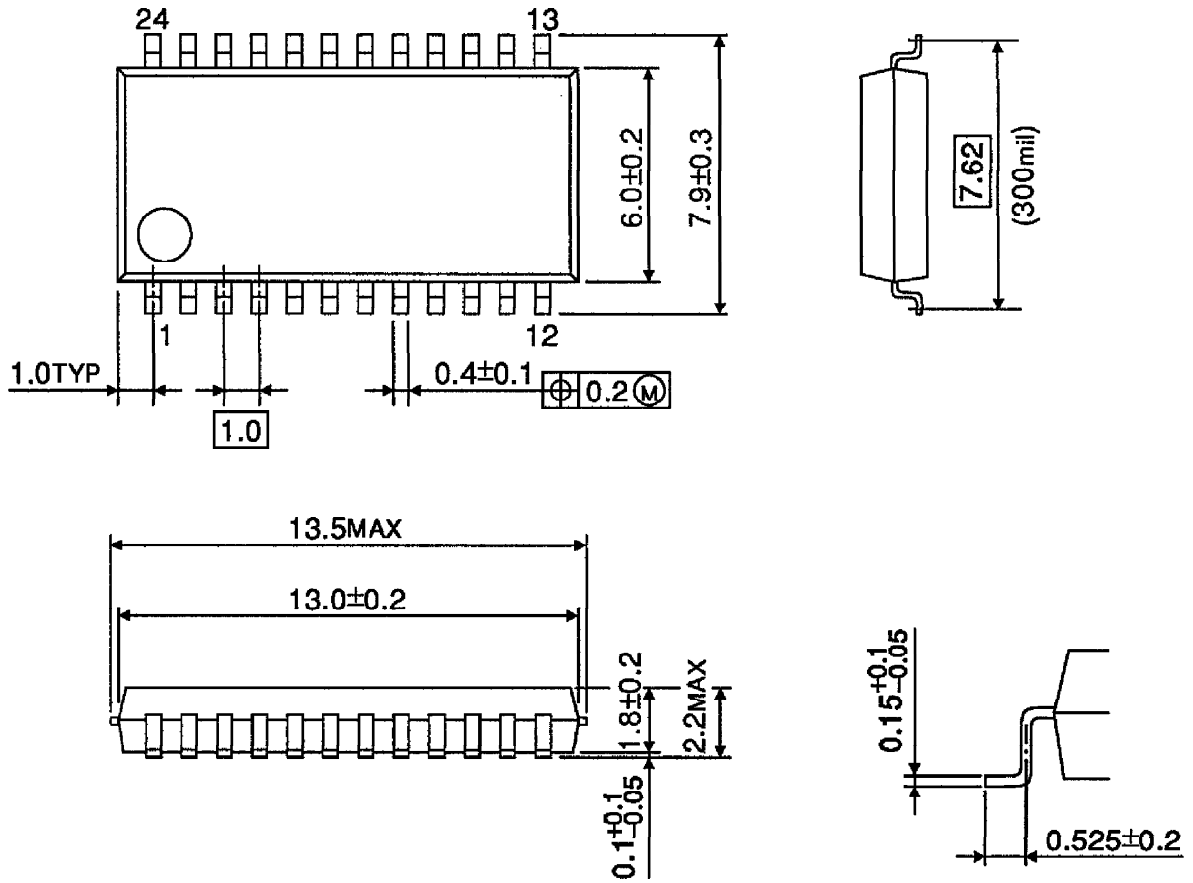

Weight : 0.31 g (Typ.)