

Diagonal 8mm (Type 1/2) Progressive Scan CCD Image Sensor with Square Pixel for EIA B/W Video Cameras

Description

The ICX074AL is an interline CCD solid-state image sensor suitable for EIA black-and-white video cameras. Progressive scan allows all pixels signals to be output independently within approximately 1/60 second. This chip features an electronic shutter with variable charge-storage time which makes it possible to realize full-frame still image without mechanical shutter. Individual pixels in a square matrix make this device suitable for image input and processing applications.

High sensitivity and low dark current are achieved through the adoption of HAD (Hole-Accumulation Diode) sensors.

Features

- Progressive scan allows individual readout of the image signals from all pixels.
- High vertical resolution (480TV-lines) still picture without mechanical shutter.
- Square pixel unit cell
- VGA format-compatible
- High resolution, high sensitivity, low dark current
- Continuous variable-speed shutter
- Low smear
- Excellent antiblooming characteristics
- Reset gate: 5V drive (bias: no adjustment)

Device Structure

- Image size: Diagonal 8mm (Type 1/2)
- Number of effective pixels: 659 (H) × 494 (V) approx. 330K pixels
- Total number of pixels: 692 (H) × 504 (V) approx. 350K pixels
- Interline CCD image sensor
- Chip size: 8.10mm (H) × 6.33mm (V)
- Unit cell size: 9.9µm (H) × 9.9µm (V)
- Optical black: Horizontal (H) direction: Front 2pixels, rear 31pixels
Vertical (V) direction: Front 8pixels, rear 2pixels
- Number of dummy bits: Horizontal 16
Vertical 5
- Substrate material: Silicon

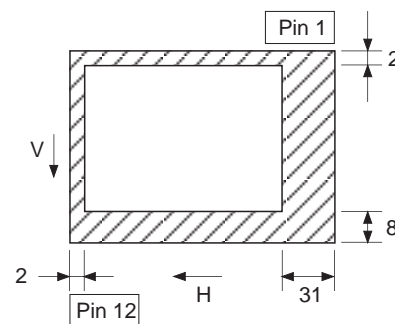
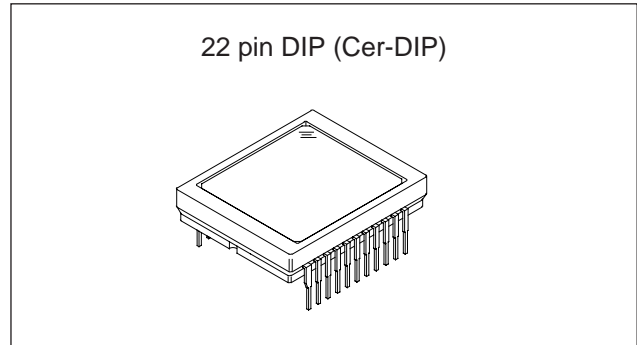

Optical black position
(Top View)

Sony reserves the right to change products and specifications without prior notice. This information does not convey any license by any implication or otherwise under any patents or other right. Application circuits shown, if any, are typical examples illustrating the operation of the devices. Sony cannot assume responsibility for any problems arising out of the use of these circuits.

Block Diagram and Pin Configuration

(Top View)

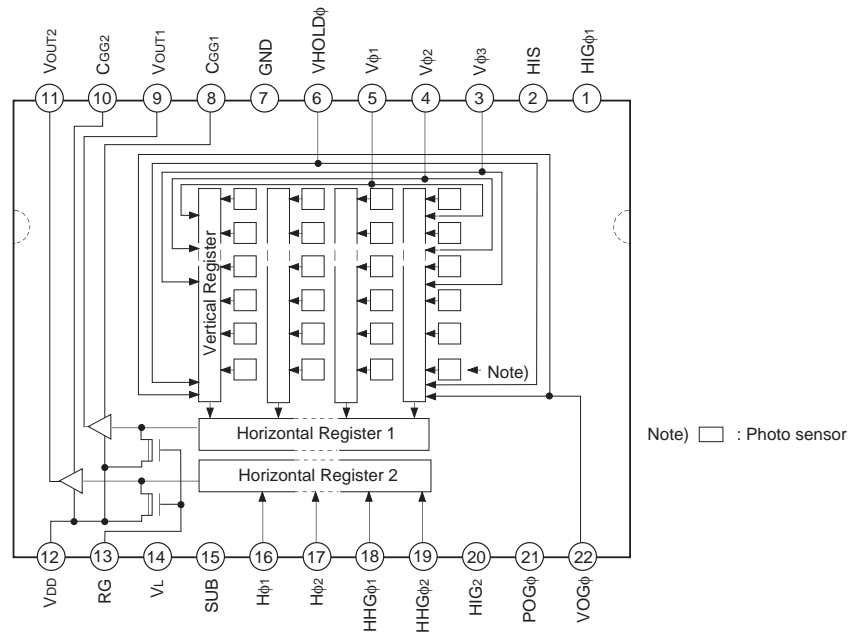

Pin Description

Pin No.	Symbol	Description	Pin No.	Symbol	Description
1	HIGφ1	Test pin *2	12	VDD	Supply voltage
2	HIS	Test pin *2	13	RG	Reset gate clock
3	Vφ3	Vertical register transfer clock	14	VL	Protective transistor bias
4	Vφ2	Vertical register transfer clock	15	SUB	Substrate (overflow drain)
5	Vφ1	Vertical register transfer clock	16	Hφ1	Horizontal register transfer clock
6	VHOLDφ	Vertical register final stage accumulation clock	17	Hφ2	Horizontal register transfer clock
7	GND	GND	18	HHGφ1	Inter-horizontal register transfer clock
8	CCG1	Output amplifier 1 gate *1 decoupling capacitor	19	HHGφ2	Inter-horizontal register transfer clock
9	VOUT1	Signal output 1	20	HIG2	Test pin *2
10	CCG2	Output amplifier 2 gate *1 decoupling capacitor	21	POGφ	Test pin *2
11	VOUT2	Signal output 2	22	VOGφ	Vertical register final stage transfer clock

*1 DC bias is applied within the CCD, so that this pin should be grounded externally through a capacitance of 1μF or more.

*2 Regarding the test pins: apply the same voltage as the supply voltage to HIS, and ground HIGφ1, HIG2, and POGφ.

Absolute Maximum Ratings

Item		Ratings	Unit	Remarks
Substrate voltage SUB – GND		–0.3 to +55	V	
Supply voltage	V _{DD} , V _{OUT1} , V _{OUT2} , HIS, C _{GG1} , C _{GG2} – GND	–0.3 to +18	V	
	V _{DD} , V _{OUT1} , V _{OUT2} , HIS, C _{GG1} , C _{GG2} – SUB	–55 to +10	V	
Clock input voltage	V _{φ1} , V _{φ2} , V _{φ3} , V _{HOLDφ} , V _{OGφ} – GND	–15 to +20	V	
	V _{φ1} , V _{φ2} , V _{φ3} , V _{HOLDφ} , V _{OGφ} – SUB	to +10	V	
Voltage difference between vertical clock input pins		to +15	V	*1
Voltage difference between horizontal clock input pins		to +17	V	
H _{φ1} , H _{φ2} – V _{OGφ}		–17 to +17	V	
H _{φ1} , H _{φ2} – GND		–10 to +15	V	
H _{φ1} , H _{φ2} – SUB		–55 to +10	V	
V _L – SUB		–65 to +0.3	V	
V _{φ2} , V _{φ3} , V _{DD} , V _{OUT1} , V _{OUT2} , HIS, HIG _{φ1} , HIG _{φ2} , POG _φ – V _L		–0.3 to +27.5	V	
RG – GND		–0.3 to +22.5	V	
V _{φ1} , C _{GG1} , C _{GG2} , H _{φ1} , H _{φ2} , HHG _{φ1} , HHG _{φ2} , VOG _φ , VHOLD _φ – V _L		–0.3 to +17.5	V	
Storage temperature		–30 to +80	°C	
Operating temperature		–10 to +60	°C	

*1 +27V (Max.) when clock width < 10μs, clock duty factor < 0.1%.

Clock Voltage Conditions

Item	Symbol	Min.	Typ.	Max.	Unit	Waveform diagram	Remarks
Readout clock voltage	V_{VT}	14.55	15.0	15.45	V	1	
Vertical transfer clock voltage	V_{VH02}	-0.05	0	0.05	V	2	$V_{VH} = V_{VH02}$
	$V_{VH1}, V_{VH2}, V_{VH3}$	-0.2	0	0.05	V	2	
	$V_{VL1}, V_{VL2}, V_{VL3}$	-8.0	-7.5	-7.0	V	2	$V_{VL} = (V_{VL01} + V_{VL03})/2$
	$V_{\phi V}$	6.8	7.5	8.05	V	2	$V_{\phi V} = V_{VHn} - V_{VLn}$ (n = 1 to 3)
	$ V_{VL1} - V_{VL3} $			0.1	V	2	
	V_{VHH}			0.5	V	2	High-level coupling
	V_{VHL}			0.5	V	2	High-level coupling
	V_{VLH}			0.5	V	2	Low-level coupling
	V_{VLL}			0.5	V	2	Low-level coupling
Horizontal transfer clock voltage	$V_{\phi H}$	4.75	5.0	5.75	V	3	
	V_{HL}	-0.05	0	0.05	V	3	
Reset gate clock voltage	$V_{\phi RG}$	4.5	5.0	5.5	V	4	Input through 0.01 μ F capacitance
	$V_{RGLH} - V_{RGLL}$			0.8	V	4	Low-level coupling
	V_{RGH}	$V_{DD} + 0.4$	$V_{DD} + 0.6$	$V_{DD} + 0.8$	V	4	
Substrate clock voltage	$V_{\phi SUB}$	21.5	22.5	23.5	V	5	
Vertical final stage accumulation clock voltage transfer clock voltage	V_{VHOLDH}, V_{VOGH}	-0.05	0	0.05	V	6	
	V_{VHOLDL}, V_{VOGL}	-8.0	-7.5	-7.0	V	6	
Inter-horizontal register transfer clock voltage	V_{HHG1H}, V_{HHG2H}	4.75	5.0	5.25	V	7	
	V_{HHG1L}, V_{HHG2L}	-8.0	-7.5	-7.0	V	7	
	V_{HHG1M}, V_{HHG2M}	-0.05	0	0.05	V	7	

Clock Equivalent Circuit Constant

Item	Symbol	Min.	Typ.	Max.	Unit	Remarks
Capacitance between vertical transfer clock and GND	$C\phi V1$		3300		pF	
	$C\phi V2$		4700		pF	
	$C\phi V3$		4700		pF	
Capacitance between vertical transfer clocks	$C\phi V12$		1000		pF	
	$C\phi V23$		22		pF	
	$C\phi V31$		100		pF	
Capacitance between vertical final stage accumulation clock and GND	$C\phi VHOLD$		19		pF	
Capacitance between vertical final stage transfer clock and GND	$C\phi VOG$		12		pF	
Capacitance between inter-horizontal register transfer clock and GND	$C\phi HHG1$		23		pF	
	$C\phi HHG2$		19		pF	
Capacitance between horizontal transfer clock and GND	$C\phi H1$		60		pF	
	$C\phi H2$		69		pF	
Capacitance between horizontal transfer clocks	$C\phi HH$		40		pF	
Capacitance between reset gate clock and GND	$C\phi RG$		9		pF	
Capacitance between substrate clock and GND	$C\phi SUB$		400		pF	
Vertical transfer clock series resistor	$R1, R2, R3$		10		Ω	
Vertical transfer clock ground resistor	R_{GND}		15		Ω	
Horizontal transfer clock series resistor	$R\phi H1$		24		Ω	
	$R\phi H2$		30		Ω	

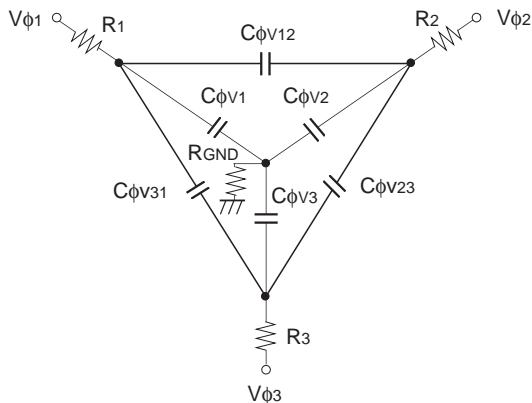

Vertical transfer clock equivalent circuit

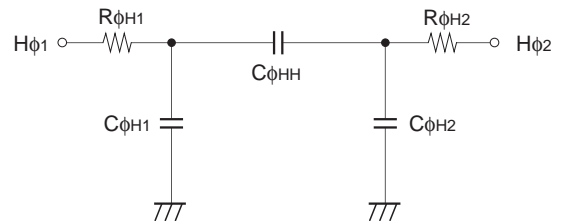

Horizontal transfer clock equivalent circuit

Drive Clock Waveform Conditions

(1) Readout clock waveform

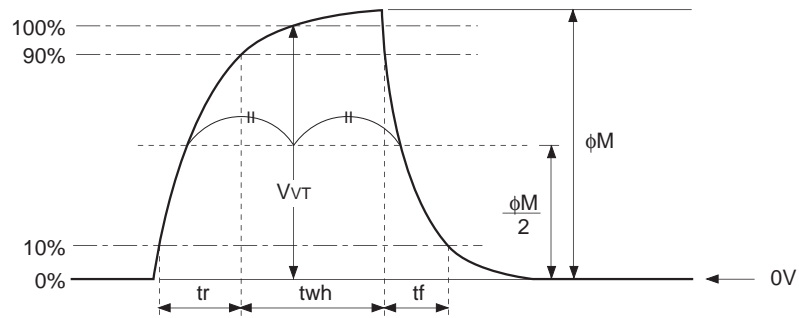

(2) Vertical transfer clock waveform

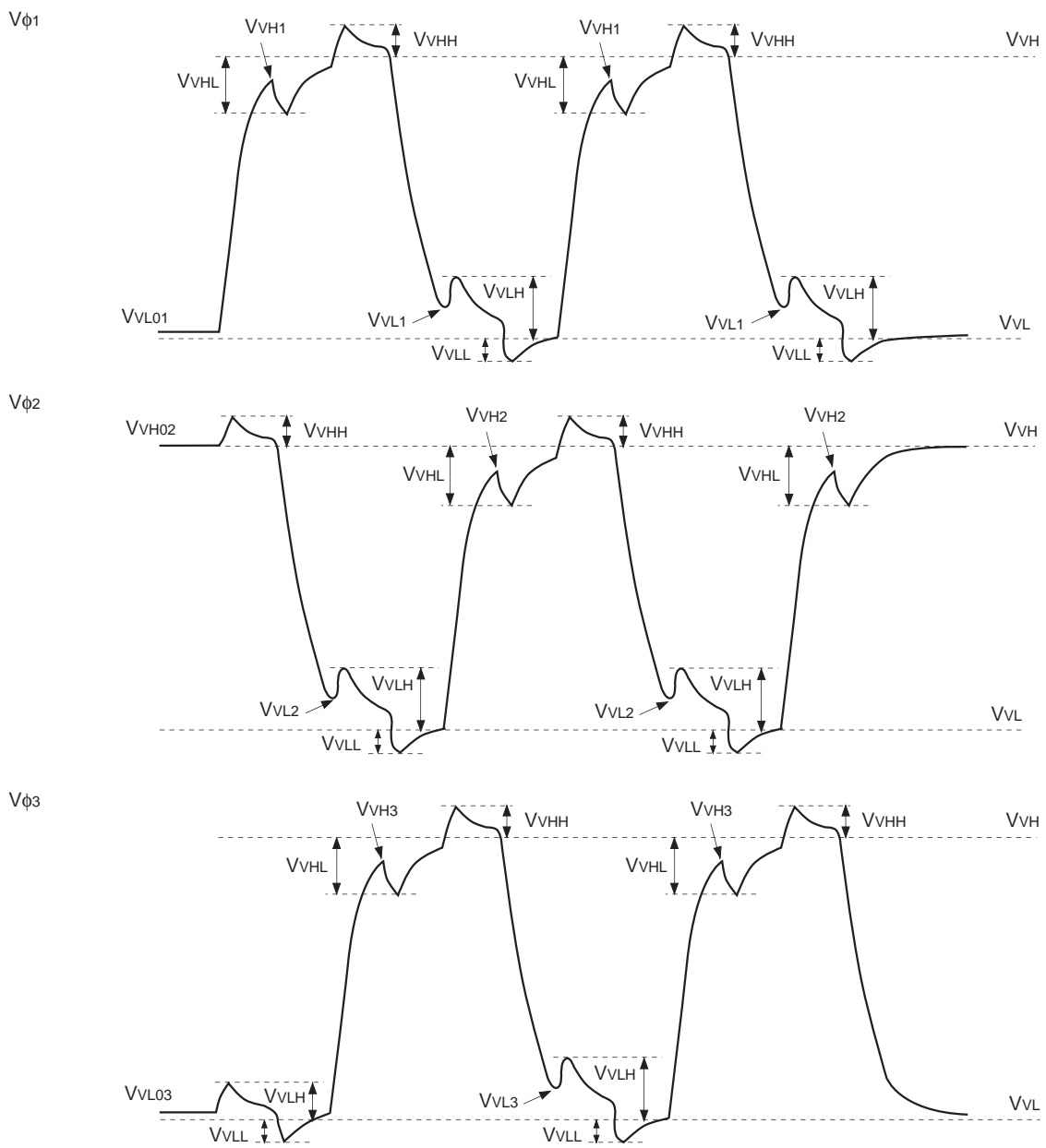

$$V_{VH} = V_{VH02}$$

$$V_{VL} = (V_{VL01} + V_{VL03}) / 2$$

$$V_{\phi 1} = V_{VH1} - V_{VL01}$$

$$V_{\phi 2} = V_{VH02} - V_{VL2}$$

$$V_{\phi 3} = V_{VH3} - V_{VL03}$$

(3) Horizontal transfer clock waveform

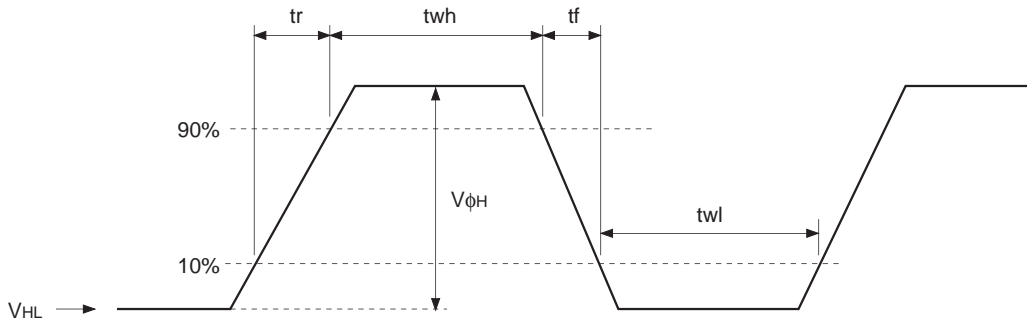

(4) Reset gate clock waveform

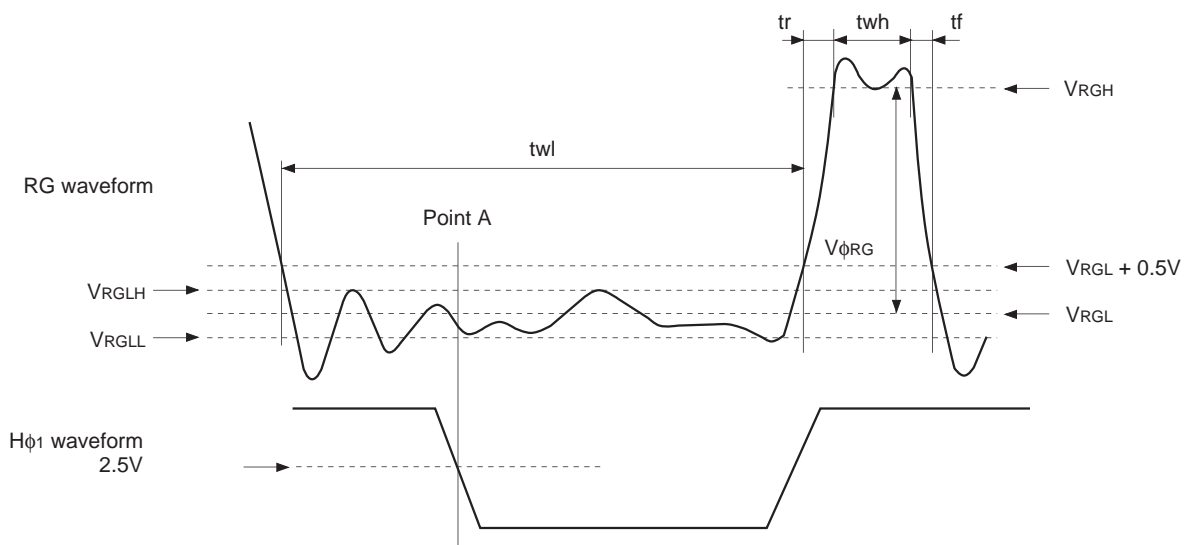

V_{RGLH} is the maximum value and V_{RGLL} is the minimum value of the coupling waveform during the period from Point A in the above diagram until the rising edge of RG. In addition, V_{RGL} is the average value of V_{RGLH} and V_{RGLL} .

$$V_{RGL} = (V_{RGLH} + V_{RGLL})/2$$

Assuming V_{RGH} is the minimum value during the interval t_{wh} , then:

$$V_{\phi RG} = V_{RGH} - V_{RGL}$$

(5) Substrate clock waveform

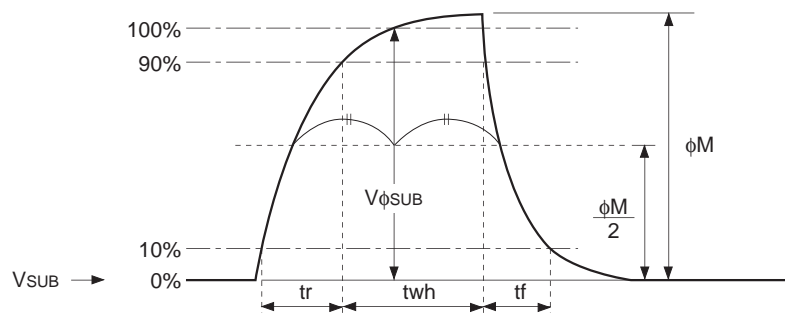

(6) Vertical final stage accumulation clock waveform - Vertical final stage transfer clock waveform

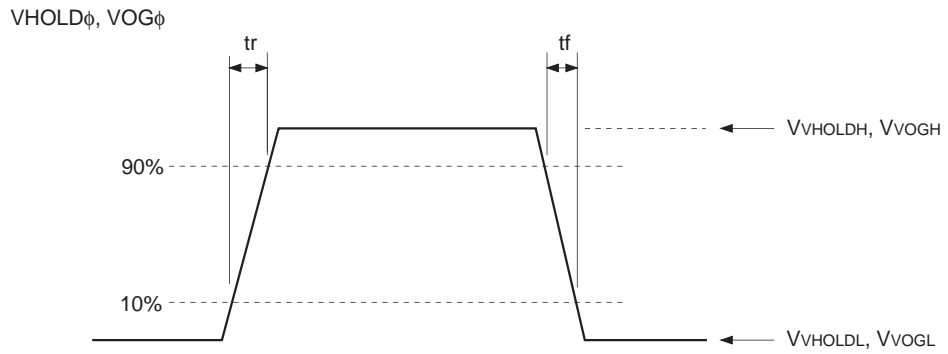

(7) Inter-horizontal register transfer clock waveform

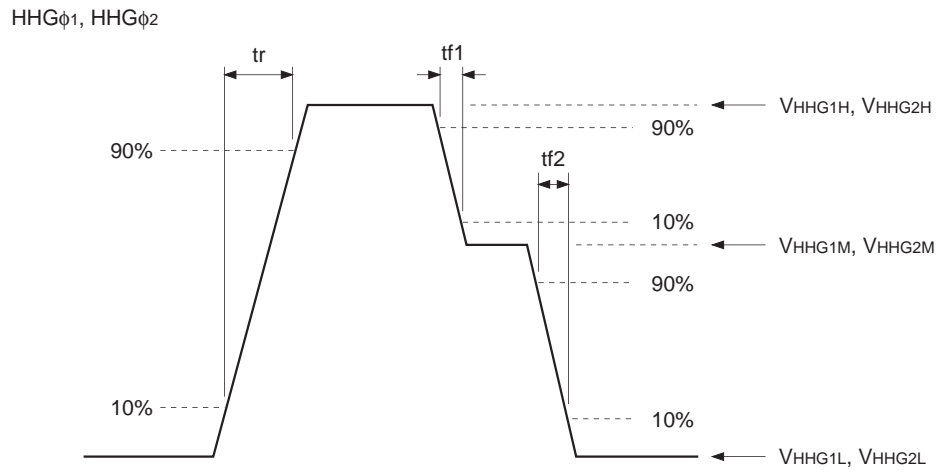

Clock Switching Characteristics

Item	Symbol	twh			twl			tr			tf, tf1, tf2			Unit	Remarks
		Min.	Typ.	Max.	Min.	Typ.	Max.	Min.	Typ.	Max.	Min.	Typ.	Max.		
Readout clock	V _T	2.3	2.5					0.5			0.5		μs	During readout	
Vertical transfer clock	V _{φ1} , V _{φ2} , V _{φ3}										15		350	ns	*1
Horizontal transfer clock	During imaging	H _{φ1}	24	29		26	31		10	17.5		10	17.5	ns	*2
		H _{φ2}	26	31		24	29		10	15		10	15		
	During parallel-serial conversion	H _{φ1}							0.01			0.01		μs	
		H _{φ2}							0.01			0.01			
Reset gate clock	φ _{RG}	11	13			64		2			2		ns		
Substrate clock	φ _{SUB}	1.6	1.9						0.5				0.5	μs	During drain charge
Vertical final stage accumulation/transfer clock	VHOLDφ							20			20		ns		
	VOGφ							20			20		ns		
Inter-horizontal register transfer clock	HHGφ ₁							20			20		ns		
	HHGφ ₂							20			20		ns		

*1 When vertical transfer clock driver CXD1268M is used.

*2 $t_f \geq t_r - 2ns$, and the cross-point voltage (V_{CR}) for the H_{φ1} rising side of the H_{φ1} and H_{φ2} waveforms must be at least 2.5V.

Item	Symbol	two			Unit	Remarks
		Min.	Typ.	Max.		
Horizontal transfer clock	H _{φ1} , H _{φ2}	24	29		ns	*3

*3 The overlap period for twh and twl of horizontal transfer clocks H_{φ1} and H_{φ2} is two.

Image Sensor Characteristics

(Ta = 25°C)

Item	Symbol	Min.	Typ.	Max.	Unit	Measurement method	Remarks
Sensitivity	S		350		mV	1	
Saturation signal	Vsat	500			mV	2	Ta = 60°C
Smear	Sm		0.002	0.007	%	3	
Video signal shading	SH			25	%	4	Zone 0
Dark signal	Vdt			2	mV	5	Ta = 60°C
Dark signal shading	ΔVdt			1	mV	6	Ta = 60°C
Lag	Lag			0.5	%	7	
Uniformity between output channels	ΔV			3	%	8	

Note) All the characteristic data of this image sensor was yielded when the sensor was operated in the 1/60s interlaced mode.

Zone Definition of Video Signal Shading

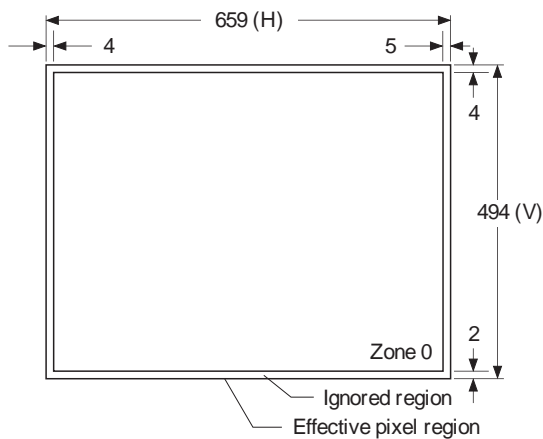

Measurement System

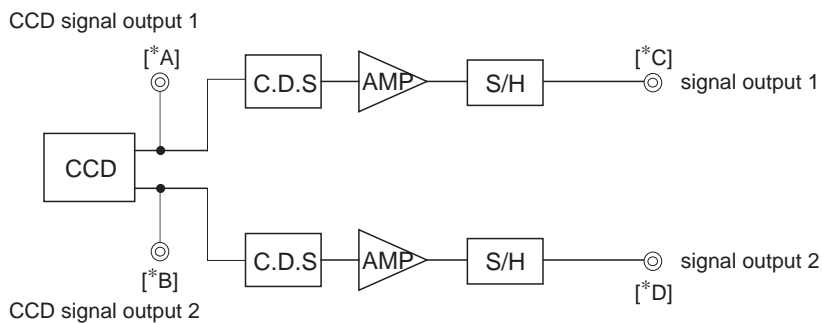

Note) Adjust the amplifier gain so that the gain between [*A] and [*C], and between [*B] and [*D] equals 1.

© Readout modes

The output methods for the two readout modes indicated below are now described.

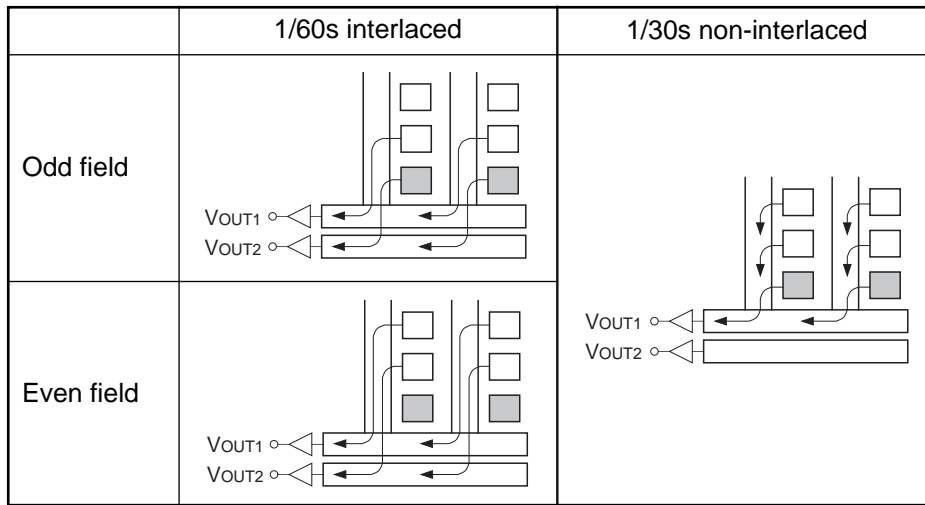

1. 1/60s interlaced

In this mode, the signals are output in a 1/60s period using the two output pins (V_{OUT1} , V_{OUT2}). The signals from two adjacent horizontal lines are simultaneously output from the respective output pins. The lines output from the output pins are changed over with each field. The V_{OUT1} signal after it has passed through the CDS and other external circuits or the signal produced by adding the V_{OUT1} and V_{OUT2} signals accommodate interlaced scanning.

2. 1/30s non-interlaced

In this mode, the signals are output in a 1/30s period using only one output pin (V_{OUT1}). Unlike the 1/60s interlaced mode described above, the external circuit can be simplified. The imaging characteristics also differ from those of the other modes.

Image Sensor Characteristics Measurement Method

◎ Measurement conditions

- 1) In the following measurements, the substrate voltage is set to the value indicated on the device, and the device drive conditions are at the typical values of the bias and clock voltage conditions.
- 2) In the following measurements, spot blemishes are excluded and, unless otherwise specified, the optical black (OB) level is used as the reference for the signal output and the value measured at point [*A] in the measurement system is used.
- 3) In the following measurements, this image sensor is operated in 1/60s interlaced mode.

◎ Definition of standard imaging conditions

1) Standard imaging condition I:

Use a pattern box (luminance 706cd/m², color temperature of 3200K halogen source) as a subject. (Pattern for evaluation is not applicable.) Use a testing standard lens with CM500S (t = 1.00mm) as an IR cut filter and image at F8. The luminous intensity to the sensor receiving surface at this point is defined as the standard sensitivity testing luminous intensity.

2) Standard imaging condition II :

Image a light source (color temperature of 3200K) with a uniformity of brightness within 2% at all angles. Use a testing standard lens with CM500S (t = 1.00mm) as an IR cut filter. The luminous intensity is adjusted to the value indicated in each testing item by the lens diaphragm.

1. Sensitivity

Set to standard imaging condition I. After selecting the electronic shutter mode with a shutter speed of 1/250s, measure the signal output (Vs) at the center of the screen and substitute the value into the following formula.

$$S = V_s \times \frac{250}{60} \text{ [mV]}$$

2. Saturation signal

Set to standard imaging condition II. After adjusting the luminous intensity to 10 times the intensity with average value of signal output, 150mV, measure the minimum value of the signal output.

3. Smear

Set to standard imaging condition II. With the lens diaphragm at F5.6 to F8, adjust the luminous intensity to 500 times the intensity with average value of signal output, 150mV. When the readout clock is stopped and the charge drain is executed by the electronic shutter at the respective H blankings, measure the maximum value VSm [mV] of the signal output and substitute the value into the following formula.

$$S_m = \frac{V_{Sm}}{150} \times \frac{1}{500} \times \frac{1}{10} \times 100 \text{ [%]} \text{ (1/10V method conversion value)}$$

4. Video signal shading

Set to standard imaging condition II. With the lens diaphragm at F5.6 to F8, adjust the luminous intensity so that the average value of the signal output is 150mV. Then measure the maximum (Vmax [mV]) and minimum (Vmin [mV]) values of the signal output and substitute the values into the following formula.

$$SH = (V_{max} - V_{min})/150 \times 100 \text{ [%]}$$

5. Dark signal

Measure the average value of the signal output (V_{dt} [mV]) with the device ambient temperature 60°C and the device in the light-obstructed state, using the horizontal idle transfer level as a reference.

6. Dark signal shading

After measuring 5, measure the maximum (V_{dmax} [mV]) and minimum (V_{dmin} [mV]) values of the dark signal output and substitute the values into the following formula.

$$\Delta V_{dt} = V_{dmax} - V_{dmin} \text{ [mV]}$$

7. Lag

Adjust the signal output value generated by strobe light to 150mV. After setting the strobe light so that it strobes with the following timing, measure the residual signal (V_{lag}). Substitute the value into the following formula.

$$\text{Lag} = (V_{lag}/150) \times 100 \text{ [%]}$$

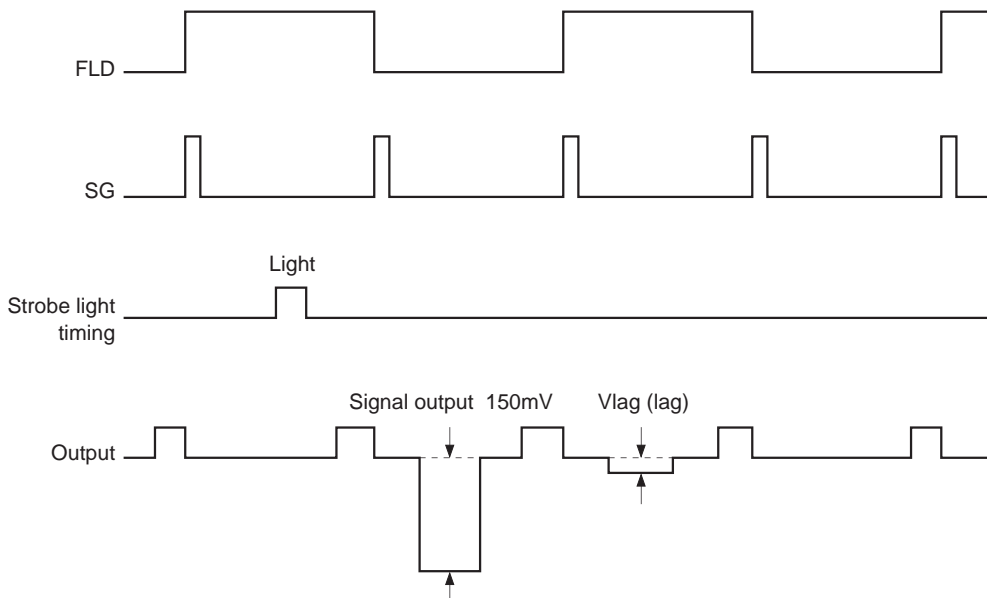

8. Uniformity between output channels

Set to standard imaging condition I. Measure the signals at signal output 1 (V_1) and at signal output 2 (V_2), and substitute the values into the following formula.

$$\Delta V = \frac{|V_2 - V_1|}{V_1} \times 100 \text{ [%]}$$

Drive Circuit

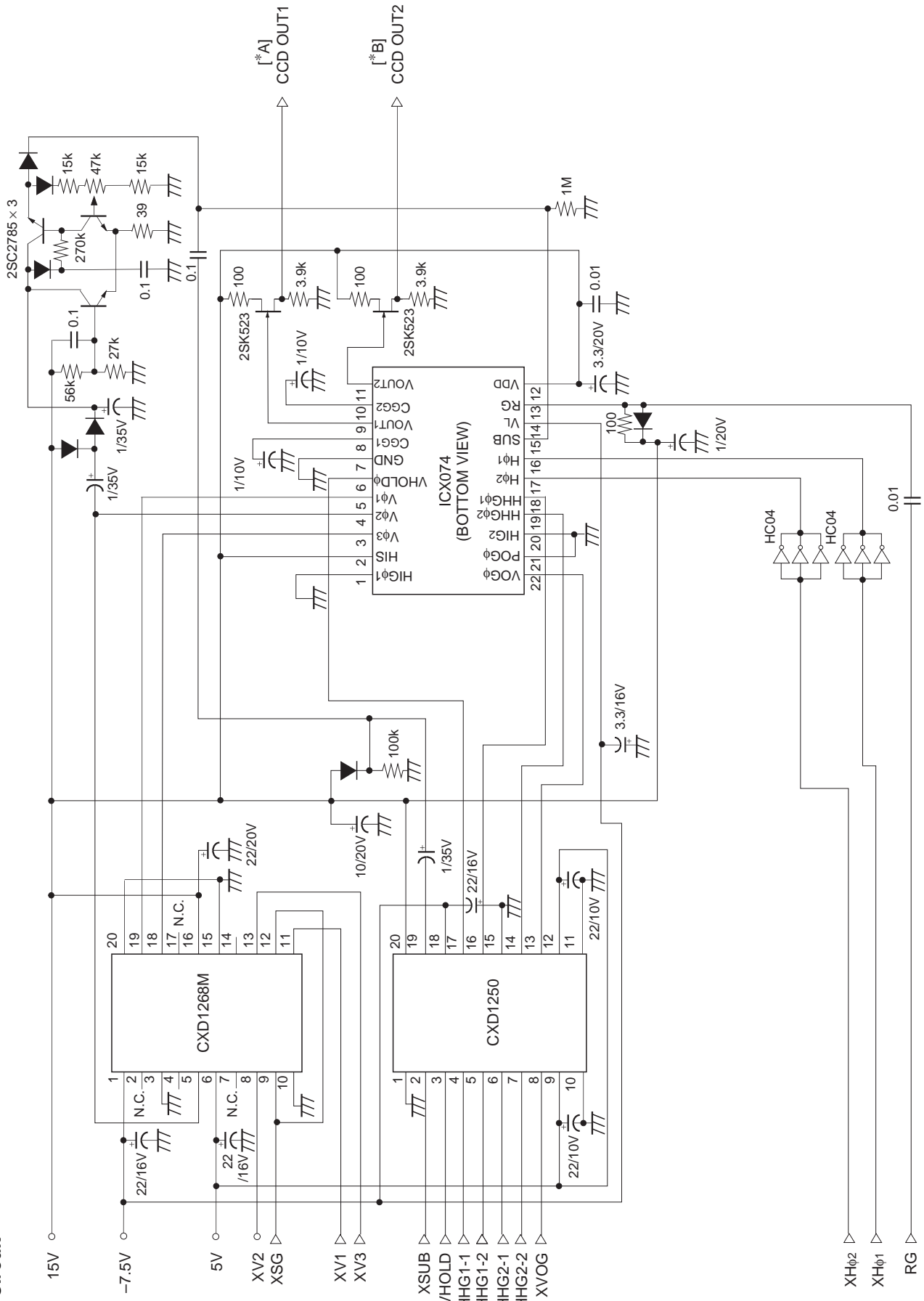

Spectral Sensitivity Characteristics

(includes lens characteristics, excludes light source characteristics)

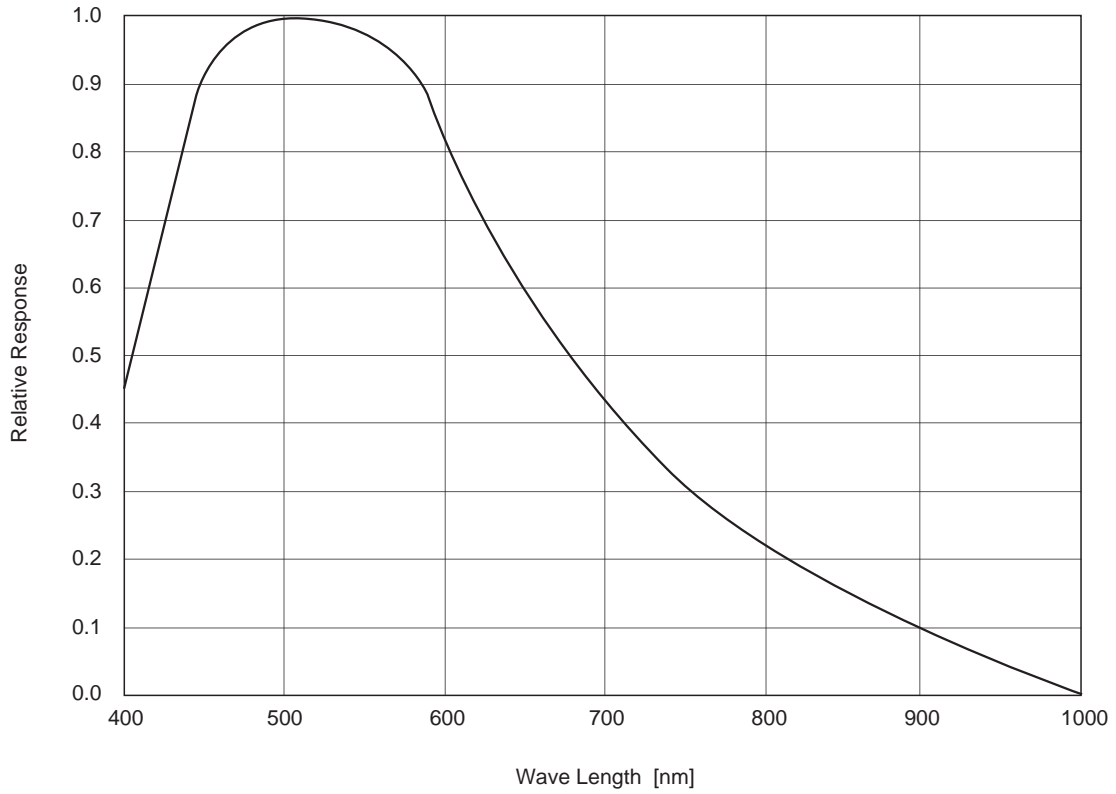

Sensor Readout Clock Timing Chart

1/60s interlaced mode

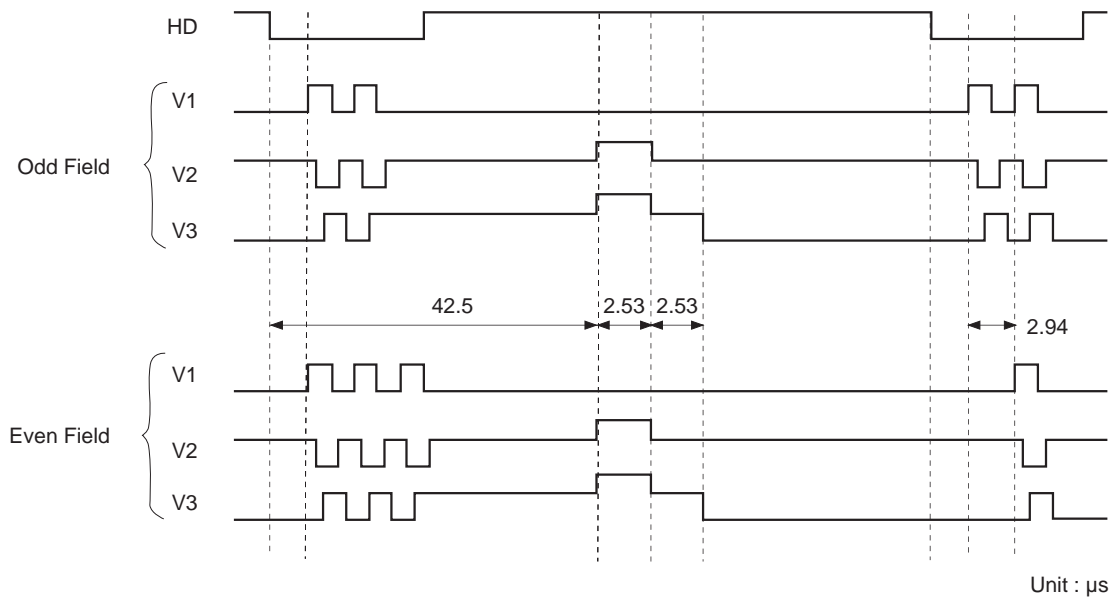

Drive Timing Chart (Vertical Sync) 1/60s interlaced mode

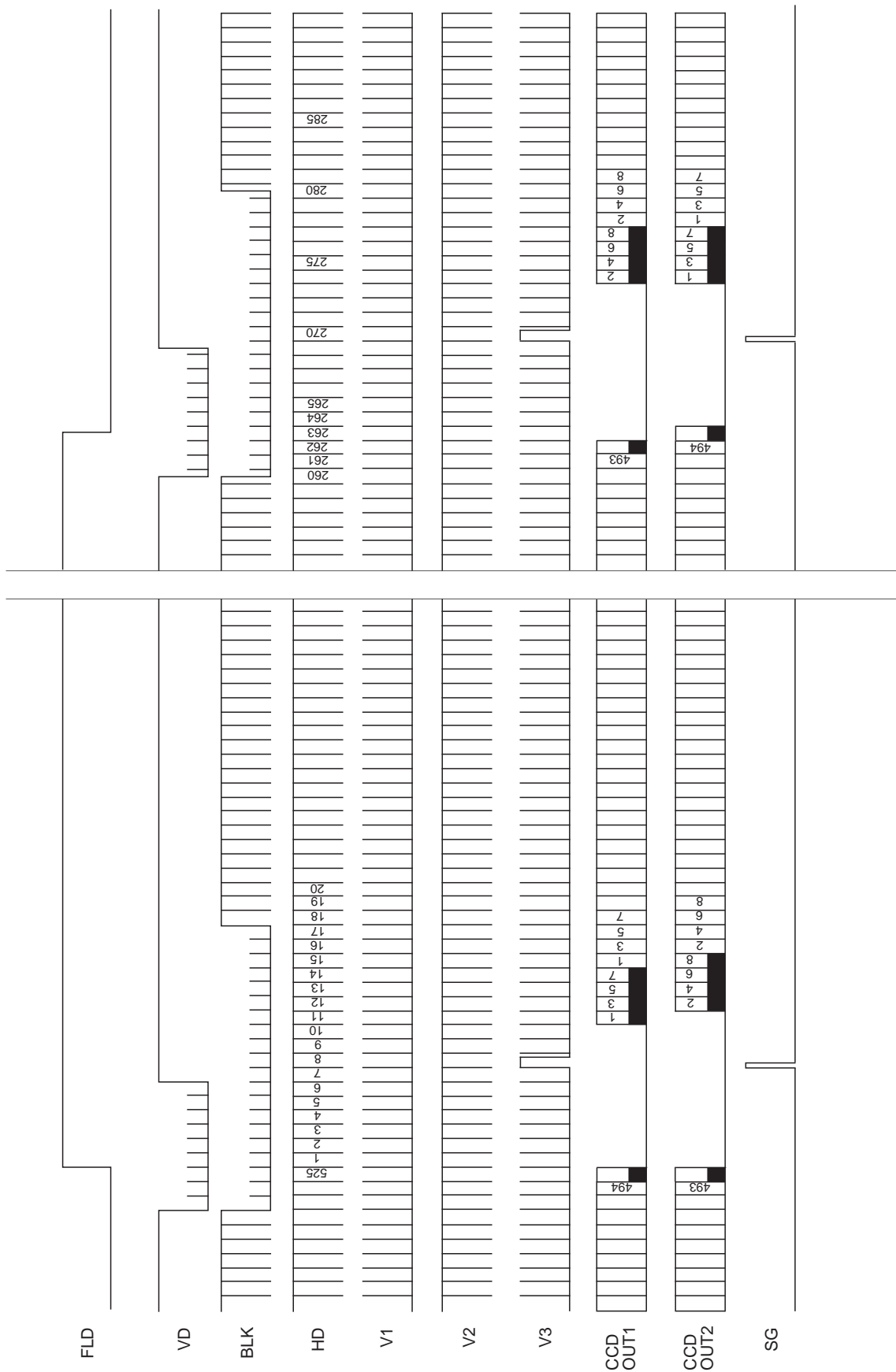

Drive Timing Chart (Horizontal Sync) 1/60s interlaced mode

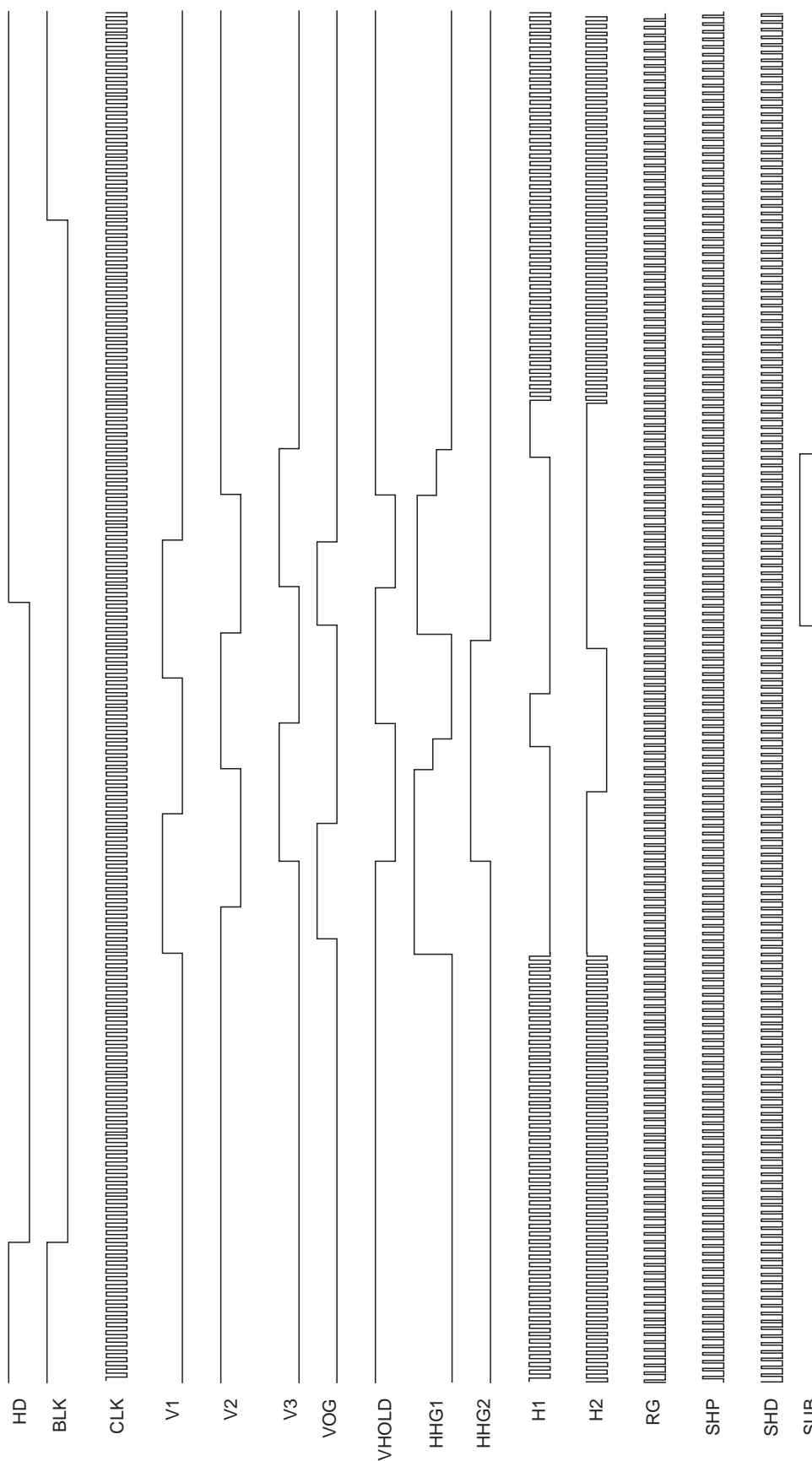

Notes on Handling

1) Static charge prevention

CCD image sensors are easily damaged by static discharge. Before handling be sure to take the following protective measures.

- Either handle bare handed or use non-chargeable gloves, clothes or material.
Also use conductive shoes.
- When handling directly use an earth band.
- Install a conductive mat on the floor or working table to prevent the generation of static electricity.
- Ionized air is recommended for discharge when handling CCD image sensor.
- For the shipment of mounted substrates, use boxes treated for the prevention of static charges.

2) Soldering

- Make sure the package temperature does not exceed 80°C.
- Solder dipping in a mounting furnace causes damage to the glass and other defects. Use a ground 30W soldering iron and solder each pin in less than 2 seconds. For repairs and remount, cool sufficiently.
- To dismount an image sensor, do not use a solder suction equipment. When using an electric desoldering tool, use a thermal controller of the zero cross On/Off type and connect it to ground.

3) Dust and dirt protection

Image sensors are packed and delivered by taking care of protecting its glass plates from harmful dust and dirt. Clean glass plates with the following operation as required, and use them.

- Perform all assembly operations in a clean room (class 1000 or less).
- Do not either touch glass plates by hand or have any object come in contact with glass surfaces. Should dirt stick to a glass surface, blow it off with an air blower. (For dirt stuck through static electricity ionized air is recommended.)
- Clean with a cotton bud and ethyl alcohol if the grease stained. Be careful not to scratch the glass.
- Keep in a case to protect from dust and dirt. To prevent dew condensation, preheat or precool when moving to a room with great temperature differences.
- When a protective tape is applied before shipping, just before use remove the tape applied for electrostatic protection. Do not reuse the tape.

4) Installing (attaching)

- Remain within the following limits when applying a static load to the package. Do not apply any load more than 0.7mm inside the outer perimeter of the glass portion, and do not apply any load or impact to limited portions. (This may cause cracks in the package.)

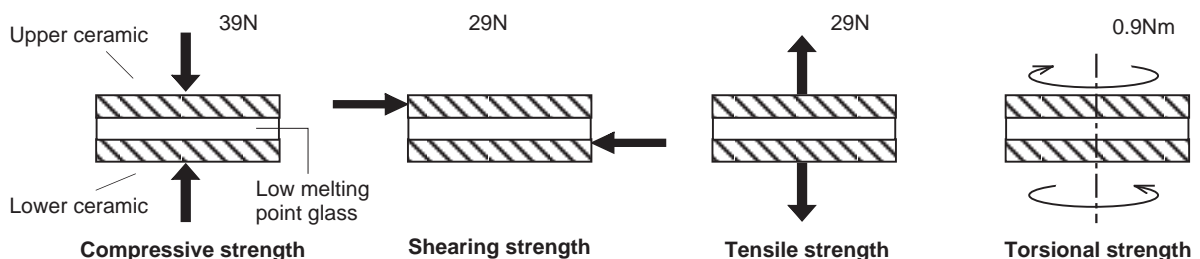

- If a load is applied to the entire surface by a hard component, bending stress may be generated and the package may fracture, etc., depending on the flatness of the ceramic portions. Therefore, for installation, use either an elastic load, such as a spring plate, or an adhesive.

- c) The adhesive may cause the marking on the rear surface to disappear, especially in case the regulated voltage value is indicated on the rear surface. Therefore, the adhesive should not be applied to this area, and indicated values should be transferred to other locations as a precaution.
- d) The upper and lower ceramic are joined by low melting point glass. Therefore, care should be taken not to perform the following actions as this may cause cracks.
- Applying repeated bending stress to the outer leads.
 - Heating the outer leads for an extended period with a soldering iron.
 - Rapidly cooling or heating the package.
 - Applying any load or impact to a limited portion of the low melting point glass using tweezers or other sharp tools.
 - Prying at the upper or lower ceramic using the low melting point glass as a fulcrum.

Note that the same cautions also apply when removing soldered products from boards.

- e) Acrylate anaerobic adhesives are generally used to attach CCD image sensors. In addition, cyanoacrylate instantaneous adhesives are sometimes used jointly with acrylate anaerobic adhesives. (reference)

5) Others

- a) Do not expose to strong light (sun rays) for long periods. For continuous using under cruel condition exceeding the normal using condition, consult our company.
- b) Exposure to high temperature or humidity will affect the characteristics. Accordingly avoid storage or usage in such conditions.

Package Outline Unit: mm

22pin DIP (600mil)

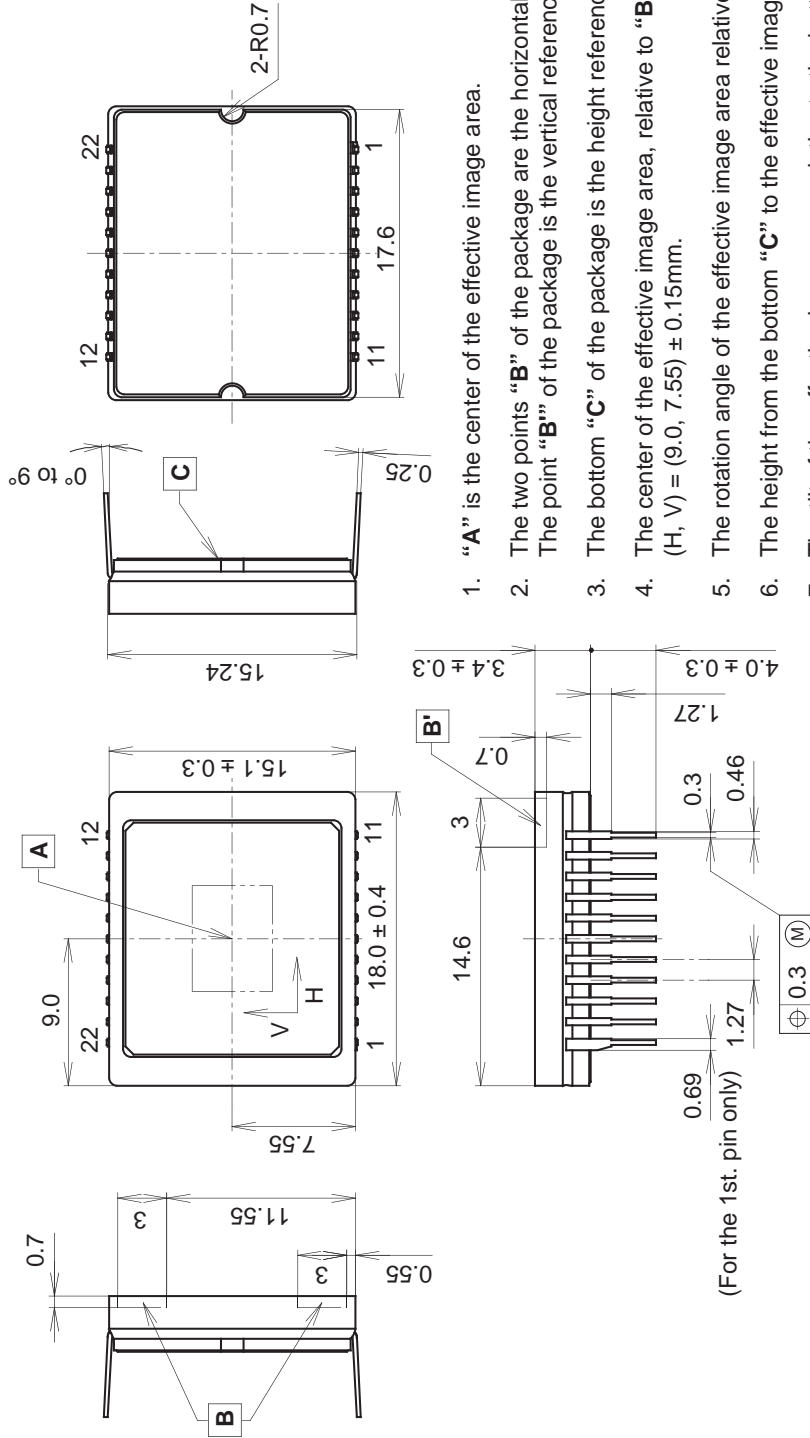

1. "A" is the center of the effective image area.
2. The two points "B" of the package are the horizontal reference. The point "B'" of the package is the vertical reference.
3. The bottom "C" of the package is the height reference.
4. The center of the effective image area, relative to "B" and "B'" is (H, V) = (9.0, 7.55) ± 0.15mm.
5. The rotation angle of the effective image area relative to H and V is ± 1°.
6. The height from the bottom "C" to the effective image area is 1.41 ± 0.15mm.
7. The tilt of the effective image area relative to the bottom "C" is less than 60µm.
8. The thickness of the cover glass is 0.75mm, and the refractive index is 1.5.
9. The notches on the bottom must not be used for reference of fixing.

PACKAGE STRUCTURE

PACKAGE MATERIAL	Cer-DIP
LEAD TREATMENT	TIN PLATING
LEAD MATERIAL	42 ALLOY
PACKAGE WEIGHT	2.6g