

# ML4642 AUI Multiplexer

## GENERAL DESCRIPTION

The ML4642 AUI Multiplexer contains all the necessary drivers/receivers and control logic to implement a 2 port MAU when used in conjunction with a transceiver chip which has a standard 802.3 AUI interface. In addition, the ML4642 is capable of operating in stand-alone mode where it interconnects two DTEs in the absence of a network MAU. Several ML4642s can be cascaded together to implement a 4 or 8 port MAU or stand-alone device.

Logic within the ML4642 detects collisions resulting from multiple DTEs transmitting simultaneously. In addition, collision signals received from a transceiver attached at the MAU port are propagated to both of the DTE ports. Jabbering DTEs are prevented from loading down the network by internal jabber timers which disable babbling ports.

## FEATURES

- IEEE 802.3 compliant AUI interfaces assure compatibility with any AUI ready devices
- No crystal or clock input
- On-chip Jabber logic, Collision Detection, and SQE test with enable/disable option
- Selectable Loopback, Jabber, and SQE Test allows cascading of multiple chips to increase DTE port

## BLOCK DIAGRAM

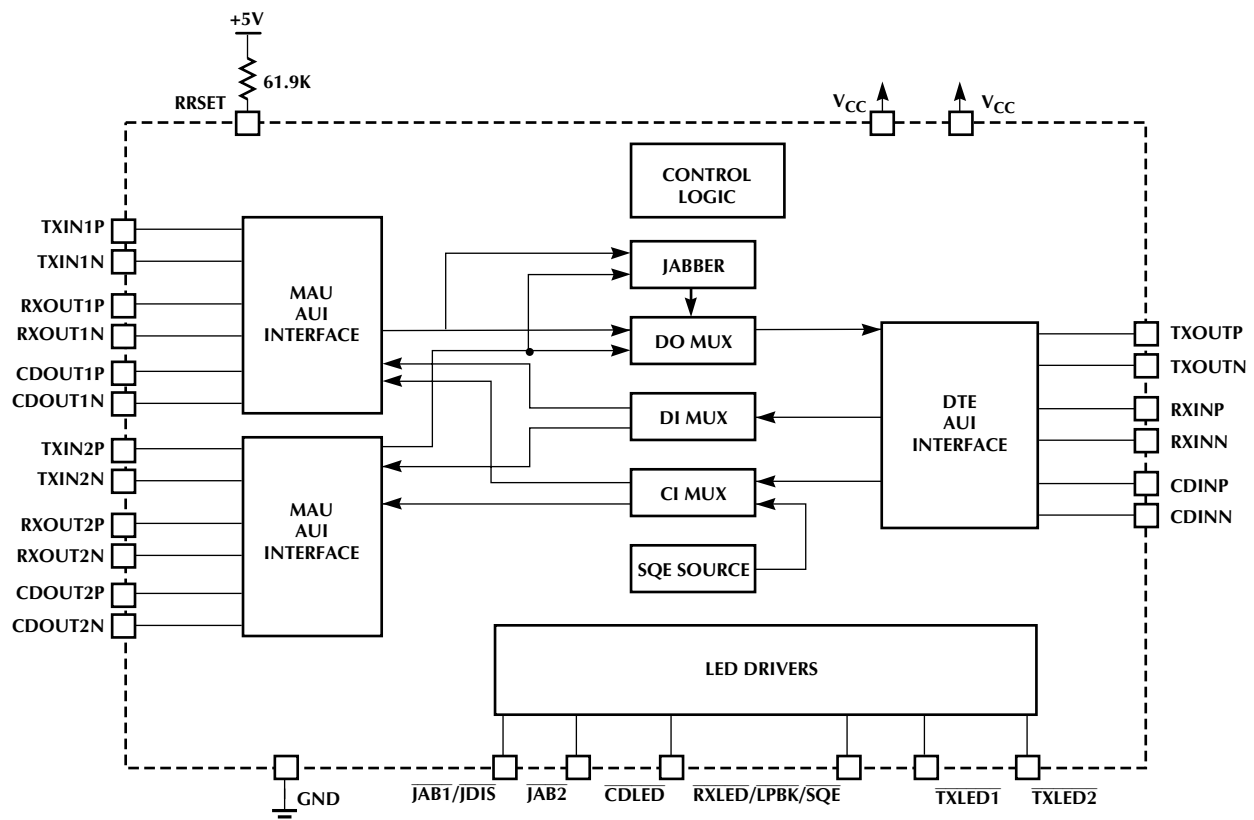

PIN CONNECTIONS

ML4642  
28-Pin SSOP (R28)

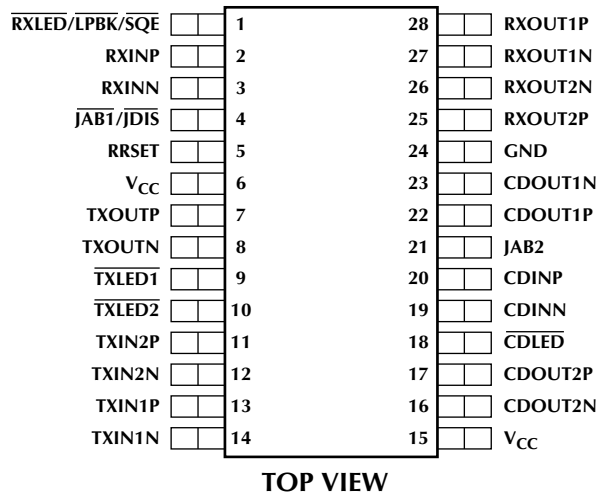

ML4642  
28-Pin PLCC (Q28)

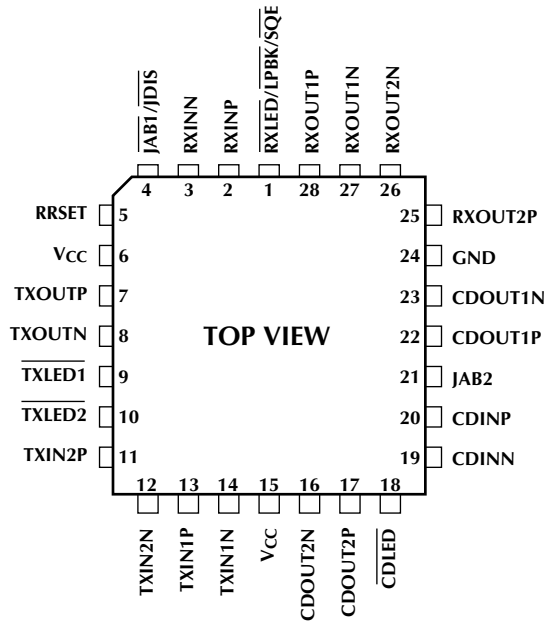

## PIN DESCRIPTIONS

PIN NO.	NAME	FUNCTION	DESCRIPTION
1	RXLED/LPBK/SQ $\bar{E}$	I/O	Active low receive LED driver for MAU port. If tied to ground, this pin enables internal loopback of the active TXIN pair to the RXOUT pairs and enables SQE test. If tied to 0.6 volts internal loopback is enable but SQE test is disabled. SQE and loopback are disabled when this pin is pulled high.
2	RXINP	Input	Receive signal pair for MAU port.
3	RXINN	Output	Receive signal pair for MAU port.
4	JAB $\bar{1}$ /JD $\bar{I}$ S	I/O	Active low jabber LED driver for DTE port 1. If tied to ground, the jabber function is disabled at TXIN1 and TXIN2.
5	RRSET	Input	Bias setting external resistor, 61.9K $\Omega$ .
6	V <sub>CC</sub>	Power	+5 volt power supply
7	TXOUTP	Output	Transmit signal pair for MAU port.
8	TXOUTN	Output	Transmit signal pair for MAU port.
9	TXLED $\bar{1}$	Output	Open collector, active low transmit LED driver for DTE AUI port 1.
10	TXLED $\bar{2}$	Output	Open collector, active low transmit LED driver for DTE AUI port 2.
11	TXIN2P	Input	Transmit signal pair for DTE port 2.
12	TXIN2N	Input	Transmit signal pair for DTE port 2.
13	TXIN1P	Input	Transmit signal pair for DTE port 1.
14	TXIN1N	Input	Transmit signal pair for DTE port 1.
15	V <sub>CC</sub>	Power	+5 volt power supply
16	CDO $\bar{U}$ T2N	Output	Collision signal pair for DTE port 2.
17	CDO $\bar{U}$ T2P	Output	Collision signal pair for DTE port 2.
18	CDLED $\bar{1}$	Output	Open collector, active low collision LED driver.
19	CDINN	Input	Collision signal pair for MAU port.
20	CDINP	Input	Collision signal pair for MAU port.
21	JAB2	Output	Open collector, active low jabber LED driver for DTE port 2.
22	CDO $\bar{U}$ T1P	Output	Collision signal pair for DTE port 1.
23	CDO $\bar{U}$ T1N	Output	Collision signal pair for DTE port 1.
24	GND	Ground	GND.
25	RXOUT2P	Output	Receive signal pair for DTE port 2.
26	RXOUT2N	Output	Receive signal pair for DTE port 2.
27	RXOUT1N	Output	Receive signal pair for DTE port 1.
28	RXOUT1P	Output	Receive signal pair for DTE port 1.

## ABSOLUTE MAXIMUM RATINGS

Absolute maximum ratings are limits beyond which the life of the integrated circuit may be impaired. All voltages unless otherwise specified are measured with respect to ground.

Power Supply Voltage Range  $V_{CC}$  . . . GND -0.3V to 6.0V  
 Input Current  $\overline{RRSET}$ ,  $\overline{JAB1}/\overline{JABD}$ ,  $\overline{JAB2}$ ,  $\overline{CDLED}$ ,  
 $\overline{RxLED}/\overline{LPBK}/\overline{SQE}$ ,  $\overline{TxLED1}$ ,  $\overline{TxLED2}$  . . . . . 60mA  
 Junction Temperature . . . . . 150°C  
 Storage Temperature . . . . . -65°C to 150°C  
 Lead Temperature (Soldering 10 seconds) . . . . . 260°C  
 Thermal Resistance ( $\theta_{JA}$ )  
 SSOP . . . . . 109°C/W  
 PLCC . . . . . 68°C/W

## OPERATING CONDITIONS

Supply Voltage ( $V_{CC}$ ) . . . . . 5V  $\pm$  10%  
 LED on Current . . . . . 10mA  
 $\overline{RRSET}$  . . . . . 61.9k $\Omega$   $\pm$  1%

## ELECTRICAL CHARACTERISTICS

Unless otherwise specified  $T_A = 0^\circ\text{C}$  to  $70^\circ\text{C}$ ,  $V_{CC} = 5\text{V} \pm 10\%$ . (Notes 1, 2)

PARAMETER	CONDITIONS	MIN	TYP.	MAX	UNITS
Power Supply Current $I_{CC}$	$V_{CC} = 5\text{V}$ , (Note 3)		60	120	mA
LED Drivers: $V_{OL}$	$R_L = 510\Omega$ for $\overline{CDLED}$ , $\overline{TxLED1,2}$ , $\overline{JAB2}$			0.8	V
	$R_L = 270\Omega$ for $\overline{JAB1}/\overline{JDIS}$ , $\overline{RxLED}/\overline{LPBK}/\overline{SQE}$	1.2	2.5	3.5	V
Transmit Squelch Voltage Level ( $T_{x+}$ , $T_{x-}$ )		-300	-250	-200	mV
Differential Output Voltage		$\pm 550$		$\pm 1200$	mV
Common Mode Output Voltage			4.0		V
Differential Output Voltage Imbalance			2	$\pm 40$	mV
$\overline{RxLED}/\overline{LPBK}/\overline{SQE}$	$\overline{SQE}$ Enabled/Loopback Enabled			0.3	V
	$\overline{SQE}$ Disabled/Loopback Enabled	0.4	0.6	0.8	V

Note 1: Limits are guaranteed by 100% testing, sampling or correlation with worst case test conditions.

Note 2: Low Duty cycle pulse testing is performed at  $T_A$ .

Note 3: This does not include the current from the AUI pull down resistors or the LED output pins.

## AC ELECTRICAL CHARACTERISTICS

SYMBOLS	PARAMETER	MIN	TYP.	MAX	UNITS
TRANSMIT					
t <sub>TXNPW</sub>	Transmit Turn-On Pulse Width		20		ns
t <sub>TXFPW</sub>	Transmit Turn-Off Pulse Width		180		ns
t <sub>XODY</sub>	Transmitter Turn-On Delay		30		ns
t <sub>TXLP</sub>	Transmit Loopback Startup Delay		40		ns
t <sub>TXSDY</sub>	Transmit Steady State Prop. Delay		15		ns
t <sub>TXJ</sub>	Transmitter Jitter		1		ns
RECEIVE					
t <sub>RXODY</sub>	Receive Turn-On Delay		20		ns
t <sub>RXSDY</sub>	Receive Steady State Prop. Delay		15		ns
t <sub>RXJ</sub>	Receiver Jitter		1		ns
t <sub>AR</sub>	Differential Output Rise Time 20% to 80% (Rx+/-, COL+/-)		3		ns
t <sub>AF</sub>	Differential Output Fall Time 20% to 80% (Rx+/-, COL+/-)		3		ns
COLLISION					
t <sub>CPSQE</sub>	Collision Present to SQE Assert	0		200	ns
t <sub>SQEXR</sub>	Time for SQE to Deactivate after a collision	100		900	ns
t <sub>CLF</sub>	Collision Frequency	8.5	10	11.5	MHz
t <sub>CLPDC</sub>	Collision Pulse Duty Cycle	40	50	60	%
t <sub>SQEDY</sub>	SQE Test Delay (Tx Inactive to SQE)	0.6	1.1	1.6	μs
t <sub>SQETD</sub>	SQE Test Duration	0.5	1.0	1.5	μs
t <sub>SQEB</sub>	SQE Blank Period	4		7	μsec
JABBER, LINK TEST AND LED TIMING					
t <sub>JAD</sub>	Jabber Activation Delay	7	13.5	20	ms
t <sub>JRT</sub>	Jabber Reset Unjab Time	250	450	750	ms
t <sub>JSQE</sub>	Delay from Outputs Disabled to Collision Oscillator On		100		ns
t <sub>LEDT</sub>	$\overline{CDLED}$ , $\overline{RxLED}$ , $\overline{TxLED1}$ , $\overline{TxLED2}$ On Time	20	50	300	ms

TIMING DIAGRAMS

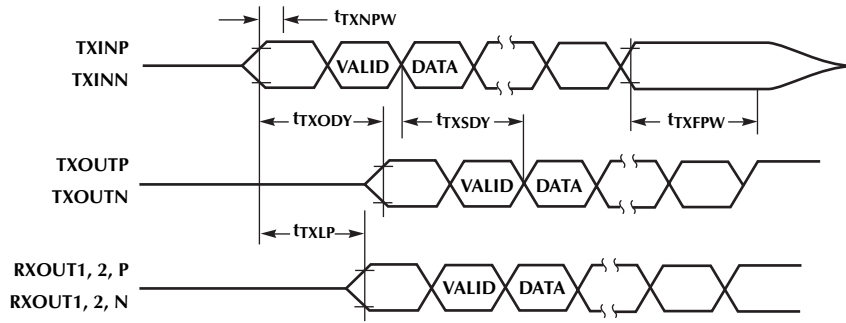

Figure 1. Transmit and Loopback Timing

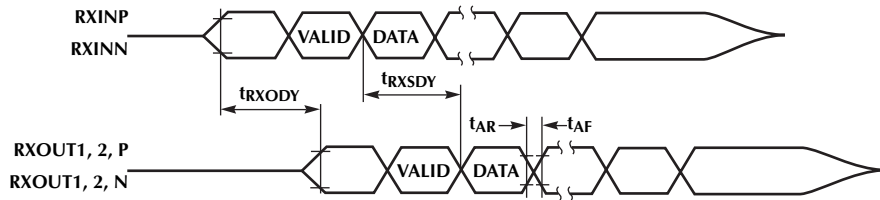

Figure 2. Receive Timing

TIMING DIAGRAMS (Continued)

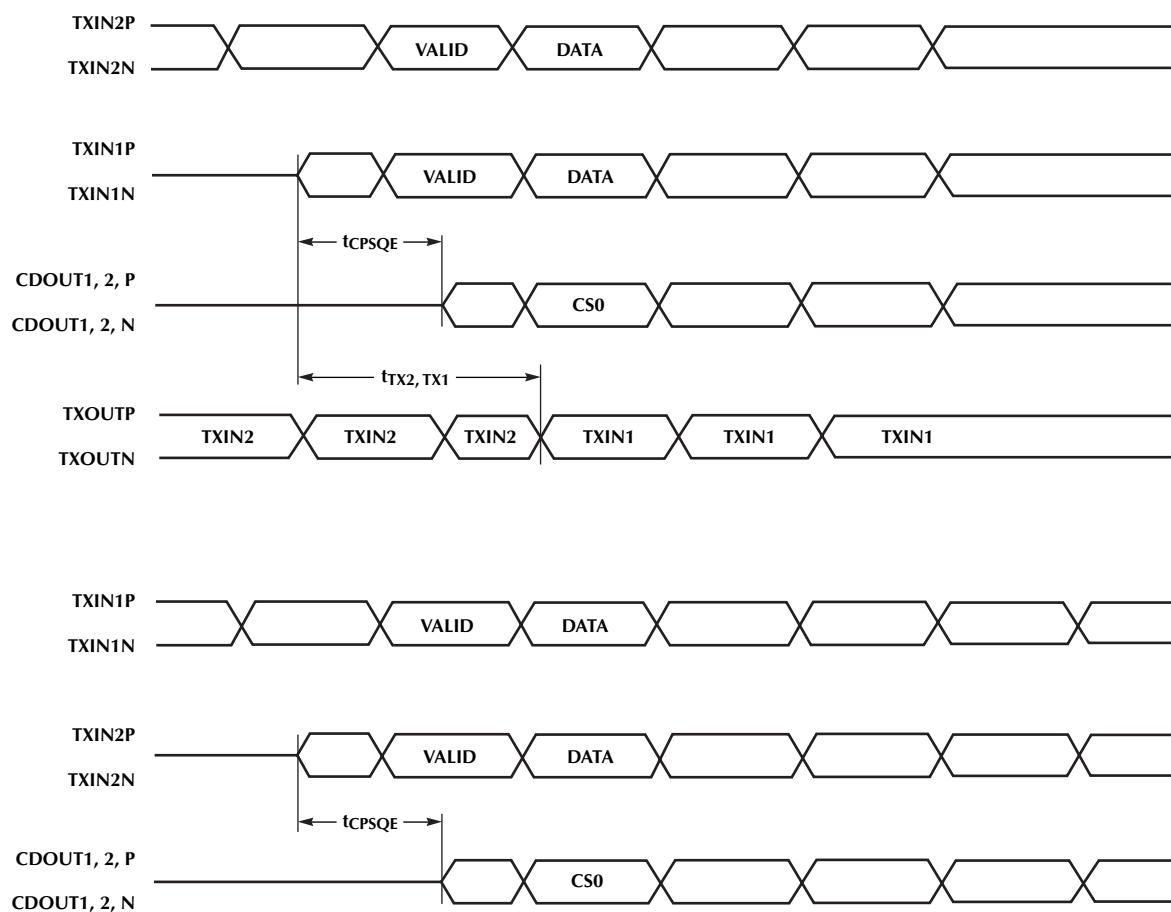

Figure 3. Collision Timing

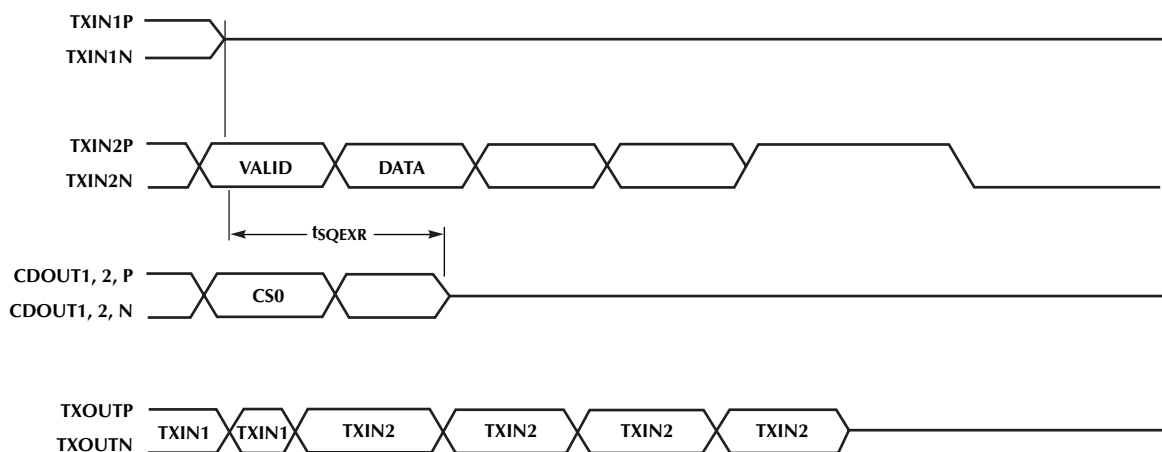

Figure 4. Collision Timing

**TIMING DIAGRAMS (Continued)**

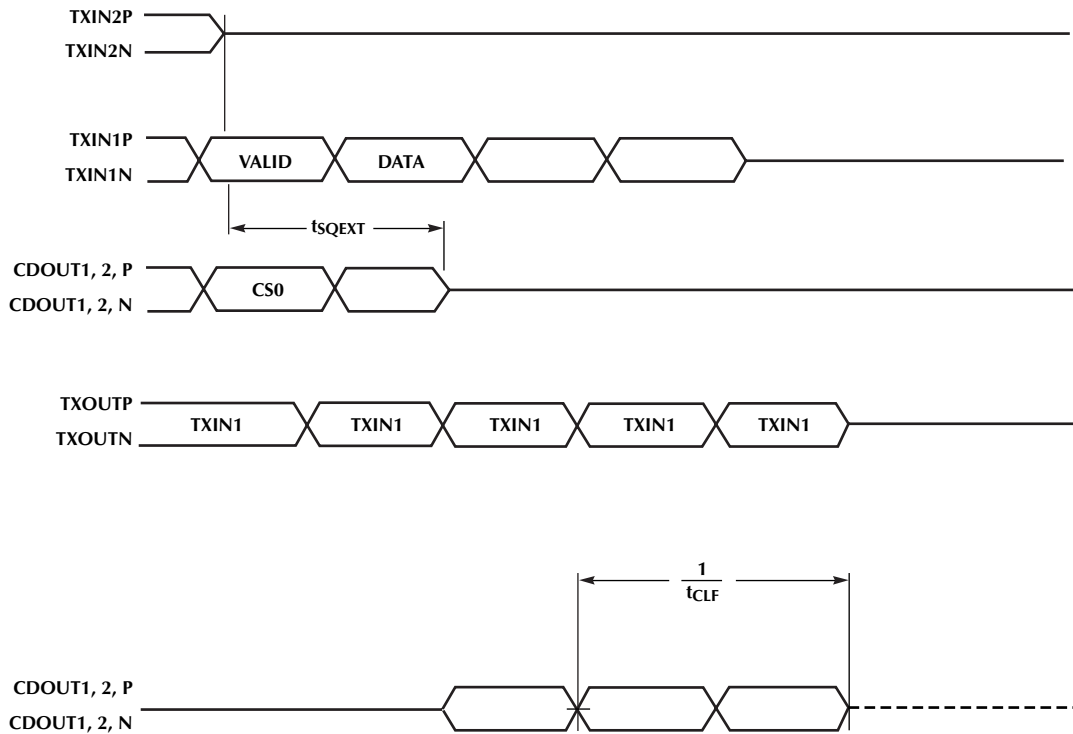

Figure 5. Collision Timing

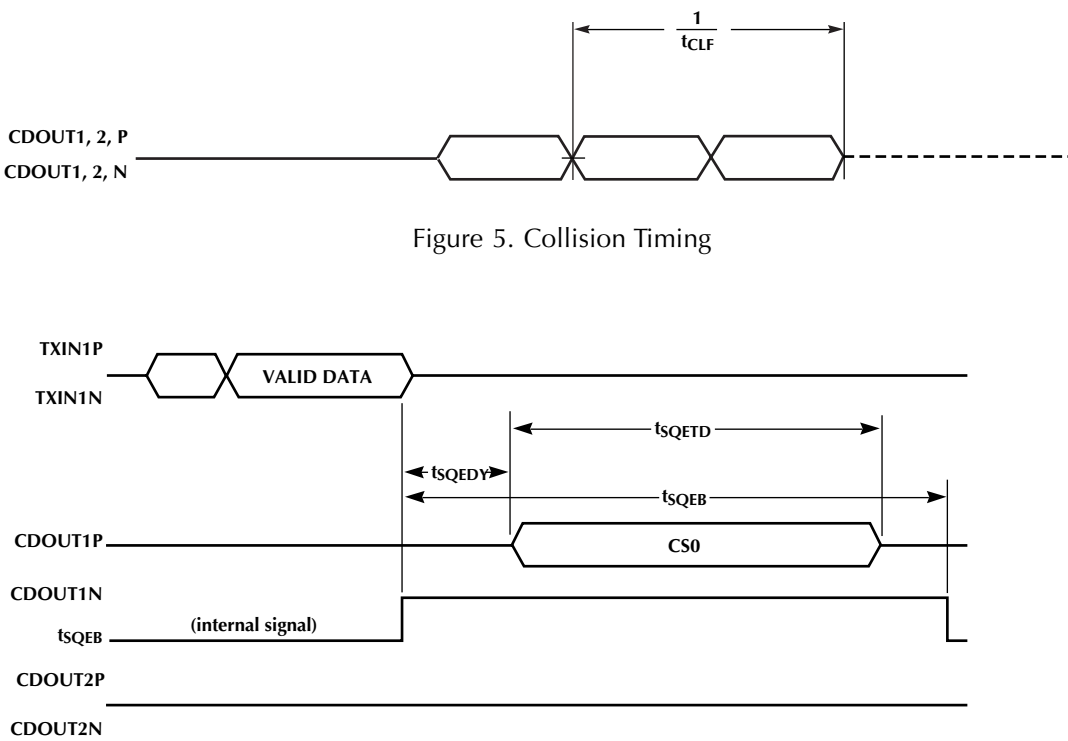

Figure 6. SQE Timing



## TIMING DIAGRAMS (Continued)

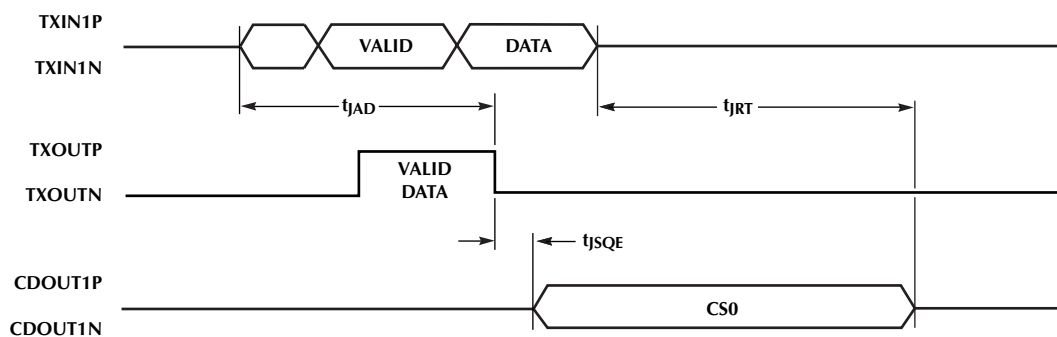

Figure 7. Jabber Timing

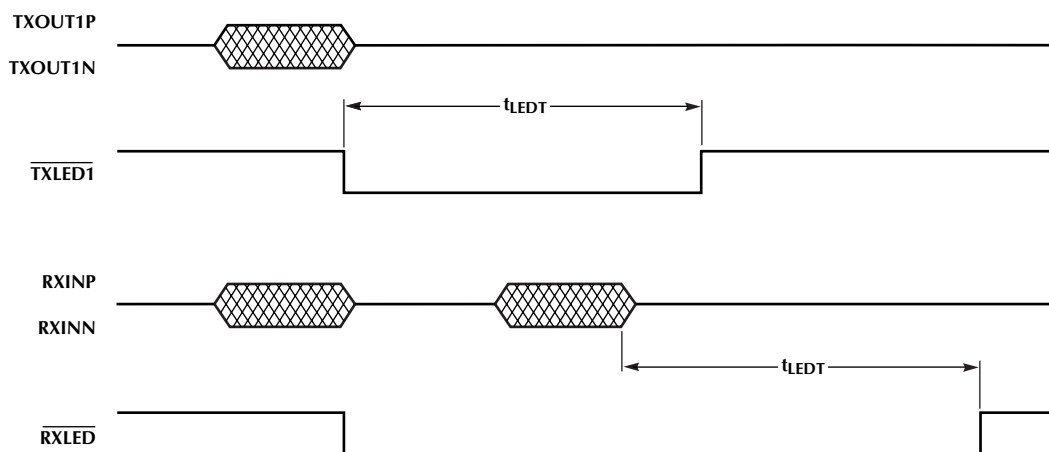

Figure 8. LED Timing

FUNCTIONAL DESCRIPTION

Figure 9 is a block diagram of a Two Port Multiplexer using the ML4642 chip. All AUI interfaces are shown AC coupled as they would be in an AUI multiplexer which does not include the MAU circuitry on the same board.

TRANSMISSION

The transmit function consists of detecting data on either of the TXIN differential receivers (TXIN1 or TXIN2) and transmitting this data out the TXOUT differential driver at the MAU port as well as both RXOUT1 and RXOUT2 drivers of the DTE ports. (Note: the looping back of data received at a TXIN pair to the RXOUT pairs is discussed in the Loopback section.)

Before data will be transmitted to the TXOUT and RXOUT pins from the TXIN pins it must meet the unsquelch requirements of the TXIN receiver circuitry. The squelch circuitry prevents any noise on the TXIN wires from being misinterpreted as data and transmitted to the TXOUT and RXOUT pins. The squelch circuit rejects signals with pulse widths less than typically 20ns and voltage levels more positive than -250mV. Once the TXIN receiver is unsquelched it remains so until reception of the input idle signal, which is detected when the TXIN signal is more positive than -170mV for longer than 180ns.

RECEPTION

The receive function consists of detecting data at the RXIN differential receiver of the MAU port transmitting this data to both DTE port RXOUT pairs.

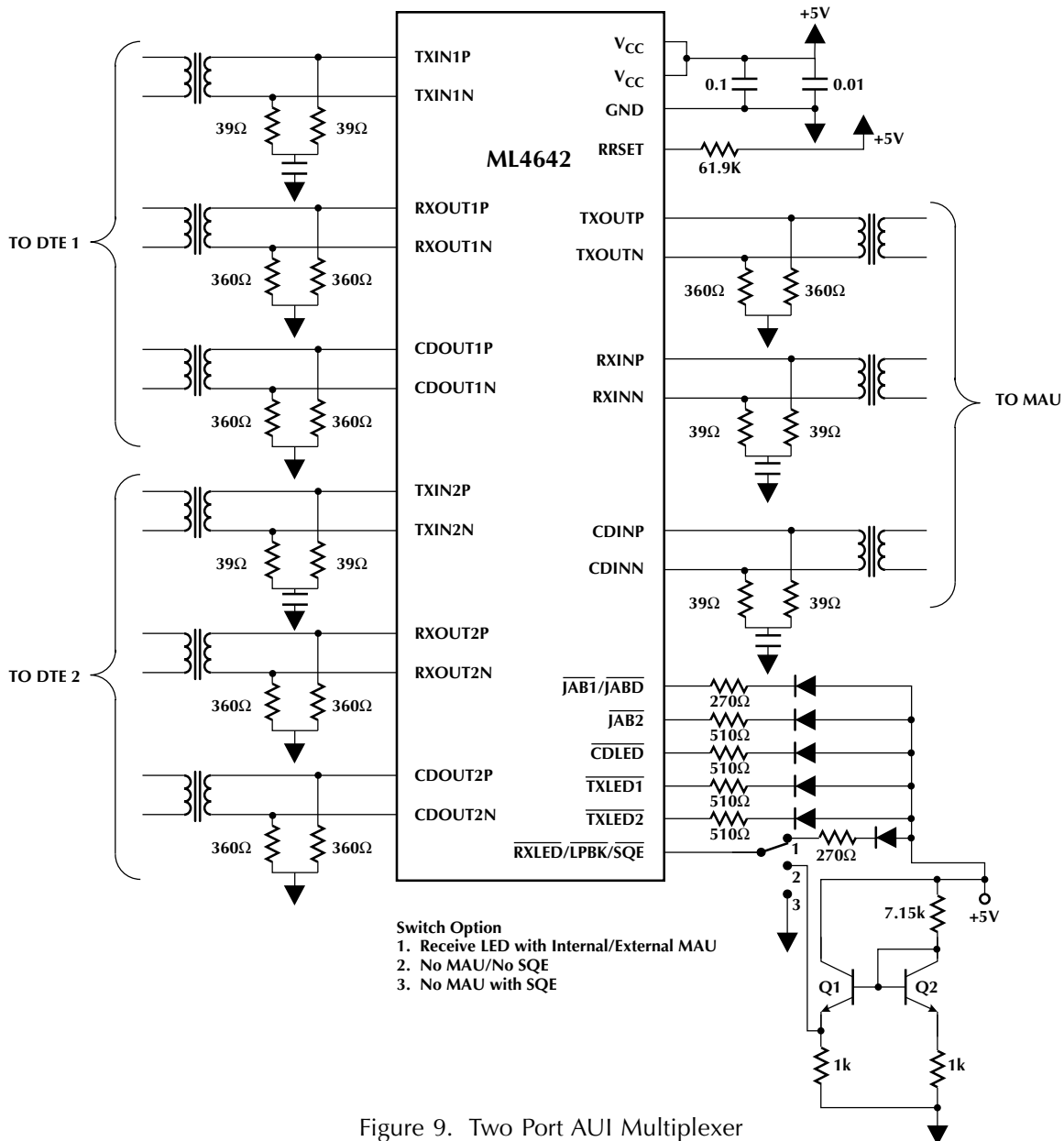

Figure 9. Two Port AUI Multiplexer

## FUNCTIONAL DESCRIPTION

Before data will be transmitted to the RXOUT pins of the DTE ports it must meet the unsquelch requirements for the RXIN receiver circuitry. The squelch circuitry at the RXIN differential receiver input performs the same function as that of the TXIN squelch circuitry using the same noise rejection criteria.

### COLLISION

There are two conditions that constitute a collision from the point of view of the ML4642:

- a) If data is received at the TXIN inputs of both DTE ports simultaneously a local collision occurs within the ML4642.
- b) If the CDIN input is active at any time other than the inter-packet gap window allowed for the SQE Test function described below.

In either of the above circumstances it is necessary for the ML4642 to drive the CDOUT pairs on both DTE ports with the collision signal. The collision signal consists of a 10 MHz  $\pm$  15% square wave matching the AUI specifications and capable of driving a 78 $\Omega$  load. The collision signal shall turn on within 2 bit times of the origination of the collision condition and shall turn off within 2–5 bit times after the collision condition subsides.

During a collision condition there are two sources for data to be transmitted to TXOUT, TXIN1 and TXIN2. The highest priority source for data to be transmitted to TXOUT is the TXIN1 receiver.

For example if TXIN2 begins transmission then TXIN1 turns on, the collision oscillator will turn on and TXOUT will switch from TXIN2 to TXIN1. If the collision ends by TXIN1 turning off first, TXOUT will switch from TXIN1 to TXIN2, and 2–5 bit times later the collision oscillator will turn off.

The MAU port's CDIN receiver contains squelch circuitry to prevent noise from causing the erroneous detection of a collision signal. A signal on the CDIN pair will not be considered active until it exceeds the same squelch requirements as those of the TXIN receivers.

### LOOPBACK

The loopback function allows the ML4642 to emulate a coaxial transceiver by propagating the TXIN data back out the RXOUT pair of the same DTE port that is sourcing the data as well as the RXOUT pair of the idle DTE port. This allows the Ethernet controller sending the data to monitor its transmit packets and detect network faults.

The loopback function is enabled at both DTE ports when the  $\overline{\text{RXLED}}$  pin is tied to ground, or 0.6 volts.

### SQE TEST FUNCTION

The Signal Quality Error (SQE) Test function allows the DTE to determine whether or not the collision detection circuitry is functional. After each transmission, during the

inter-packet gap time, the collision signal will be activated on the CDOUT pair of the same port as the TXIN pair which received the packet, for typically 1  $\mu$ s. The SQE function will not be activated on DTE ports of the ML4642 which are in the Jabber state. The SQE function is enabled on both DTE ports when the  $\overline{\text{RXLED}}$ / $\overline{\text{LPBK/SQE}}$  pin is grounded.

### JABBER

The jabber function prevents a babbling transmitter from loading down the network. Within the ML4642 is a jabber timer on each TXIN receiver. Each timer starts at the beginning of a received packet and resets at the end of each packet. If a packet lasts longer than 7 to 20ms the jabber logic disables its corresponding TXIN receiver (thus preventing its data from being retransmitted) and generates a collision signal on the babbling port's CDOUT pair. When the TXIN pair finally goes idle, a second timer measures 0.5 seconds of idle on TXIN prior to re-enabling the receiver and turning off the collision signal. If the TXIN pair becomes active again before the 0.5 seconds has expired, the timer is reset and measures another 0.5 seconds of idle time.

The jabber function can be disabled on both ports by tying the JAB1/JABD pin to ground.

### LED DRIVERS

The ML4642 has six LED driver pins. Each DTE port has a transmit LED and a jabber LED and the MAU port has a receive LED. Additionally, there is a collision LED which indicates the presence of a collision condition. All LED drivers are active low 10mA current sources.

The  $\overline{\text{TXLED}}$ ,  $\overline{\text{RXLED}}$ , and  $\overline{\text{CDLED}}$  outputs have 50ms pulse stretchers on them to enable the LEDs to be visible. The  $\overline{\text{JLED}}$  outputs do not have pulse stretchers on them because their conditions occur long enough for the LEDs to be visible.

Two of the ML4642 LED outputs serve as configuration pins as well.  $\overline{\text{RXLED/LPBK/SQE}}$  and  $\overline{\text{JAB1/JDIS}}$  may be tied through a resistor to  $V_{CC}$ , tied through a resistor and a LED to  $V_{CC}$  or grounded. Additionally  $\overline{\text{RXLED/LPBK/SQE}}$  may be tied to a specific voltage. When these pins are grounded or tied to a 0.6 Volts they become configuration inputs. Otherwise when tied high they become status outputs.

### CASCADING THE ML4642 FOR 4 AND 8 PORT DESIGNS

The configurability of such functions as loopback, jabber, and SQE allows ease of cascading multiple ML4642 chips for larger fan-out designs. Figure 10 shows a four port AUI Multiplexer design. For a type 0 configuration both jabber and transmit LEDs are available on a per port basis for status. The  $\overline{\text{RXLED/LPBK/SQE}}$  pins are tied through a resistor to 5 volts, and  $\overline{\text{CDLED}}$  is wire OR'ED with the other chip for one collision detect status LED per system. There is also only one receive LED status output which is displayed in a type 2 configuration. This particular pin in

FUNCTIONAL DESCRIPTION

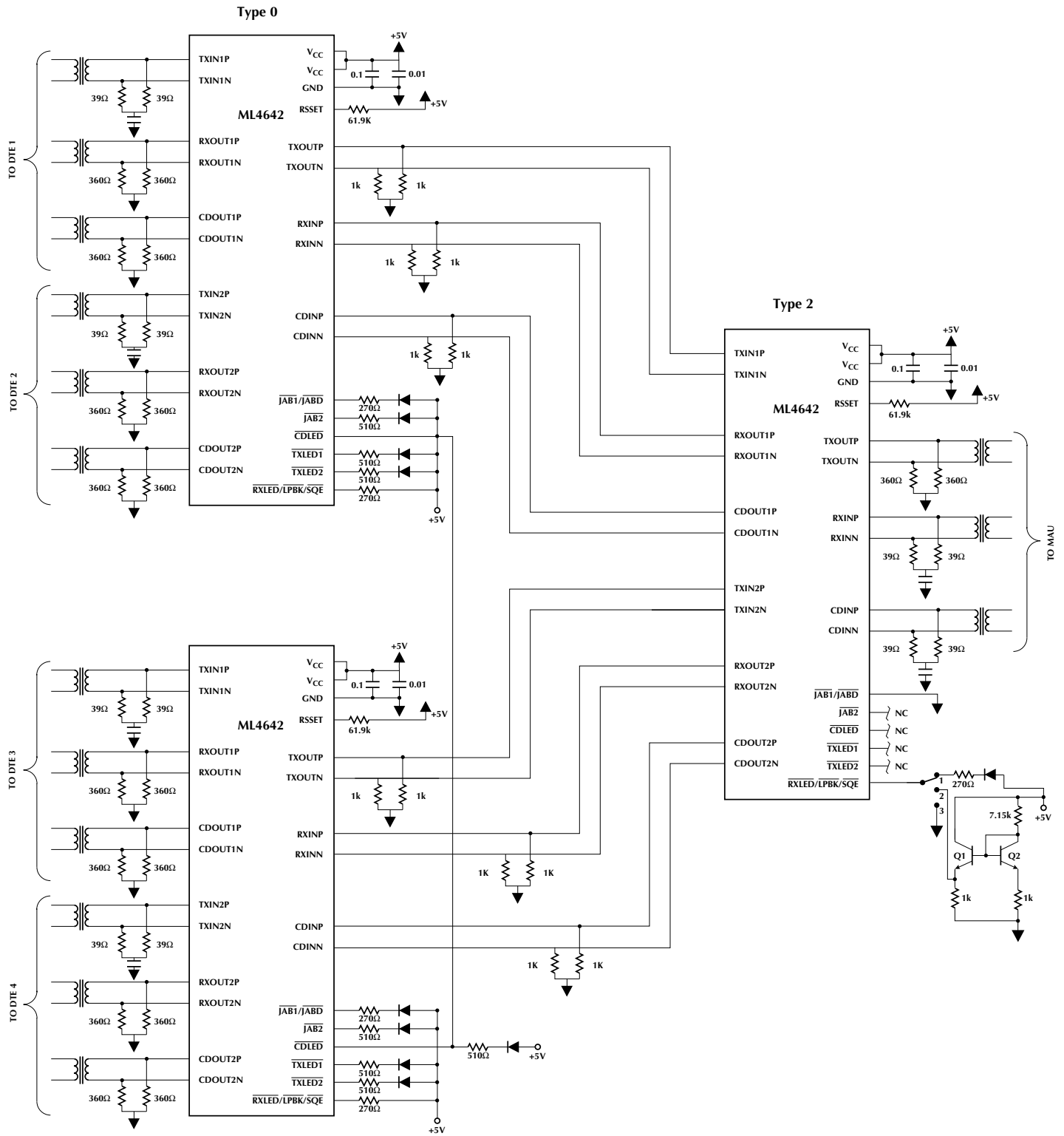

- Switch Options
1. Receive LED with Internal/External MAU
  2. No MAU/No SQE
  3. No MAU with SQE

Figure 10. Four Port AUI Multiplexer

## FUNCTIONAL DESCRIPTION

a type 2 configuration offers three options. In option 1, when tied to +5 volts through a resistor and an LED, an internal or external MAU will be connected. For stand-alone operation without an internal or external MAU a loopback is required. Option 2 allows loopback with no SQE test while option 3 provides loopback with an SQE test.

An eight port design is accomplished in the same way as shown in the block diagram in Figure 11. In an eight port design Type 0 and Type 2 configuration remain the same as in a four port design. Type 1 however only differs from Type 2 by tying  $\overline{\text{RXLED/LPBK/SQE}}$  through a resistor to +5 volts. Table 1 summarizes all of the different LED configurations.

### SQE TEST WHEN CASCADING

As mentioned before, after each transmission during the interpacket gap time the collision signal will be activated on the CDOUT pair of the same port as the TXIN pair which received the packet. When cascading ML4642s to implement 4 or 8 port designs, the path is remembered and followed to achieve this function. The paths that did not carry the transmit data blocks CDOUT for 4-7  $\mu\text{sec}$  after transmission to guarantee that only the port that transmitted will see SQE test.

TABLE 1. LED Configurations for 2, 4, and 8 Port Designs

	JAB1/JABD	RXLED/LPBK/SQE	JAB2	CDLED	TXLED1	TXLED2
Two Port AUI Mux	LED	GND, 0.6V, LED	LED	LED	LED	LED
Type 0	LED	270 $\Omega$ to +5V	LED	WIRE'ORED	LED	LED
Type 1	GND	270 $\Omega$ to +5V	NC	NC	NC	NC
Type 2	GND	GND, 0.6V, LED	NC	NC	NC	NC

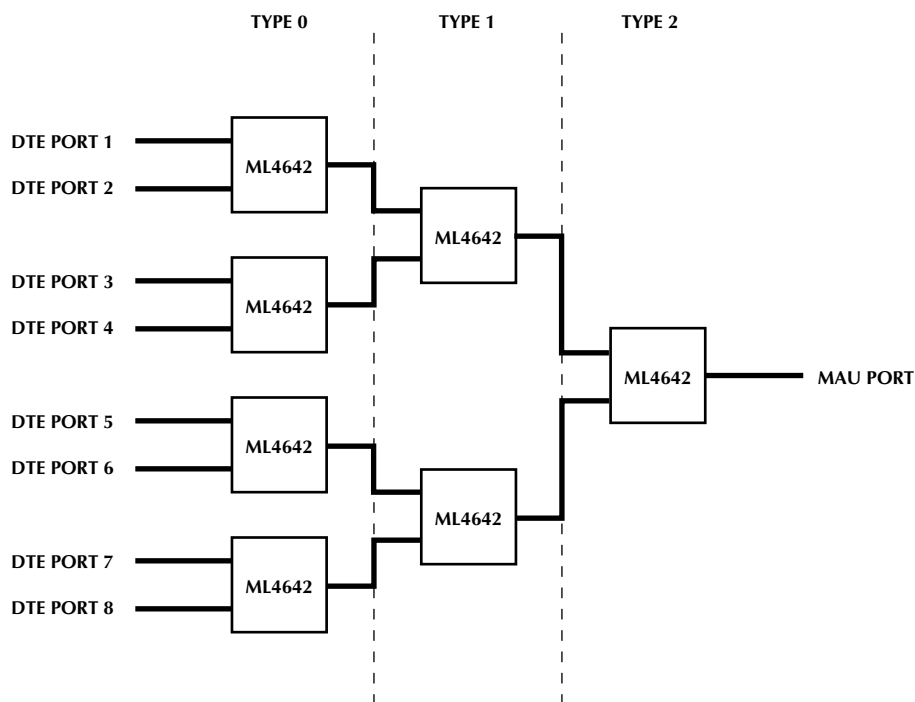
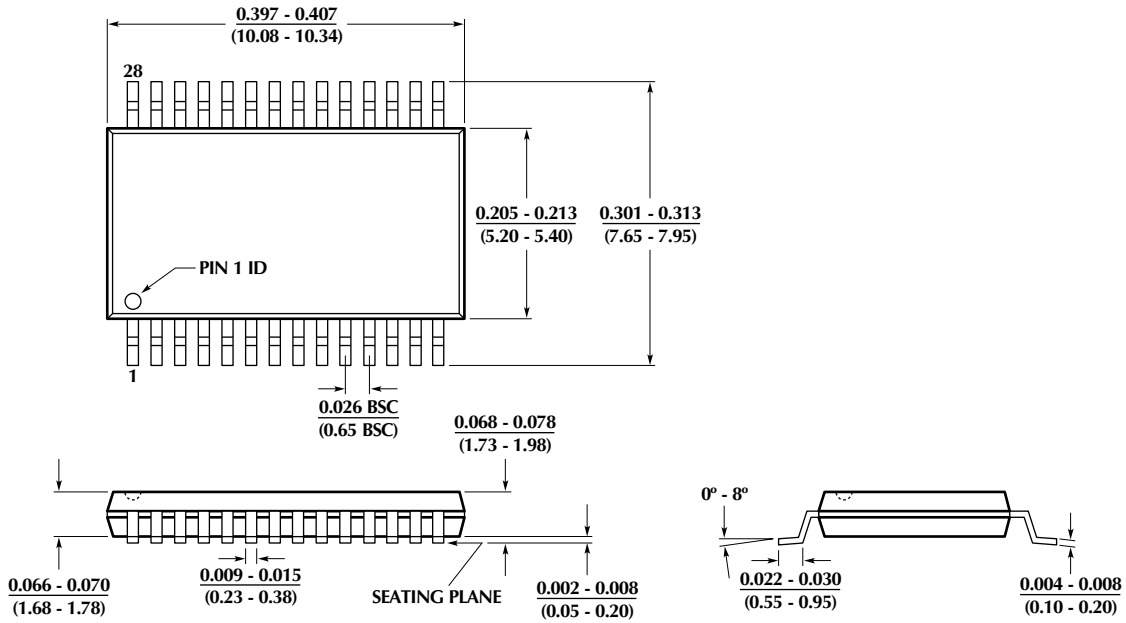

Figure 11. Eight Port AUI Multiplexer

PHYSICAL DIMENSIONS inches (millimeters)

Package: R28  
28-Pin SSOP



Package: Q28  
28-Pin PLCC

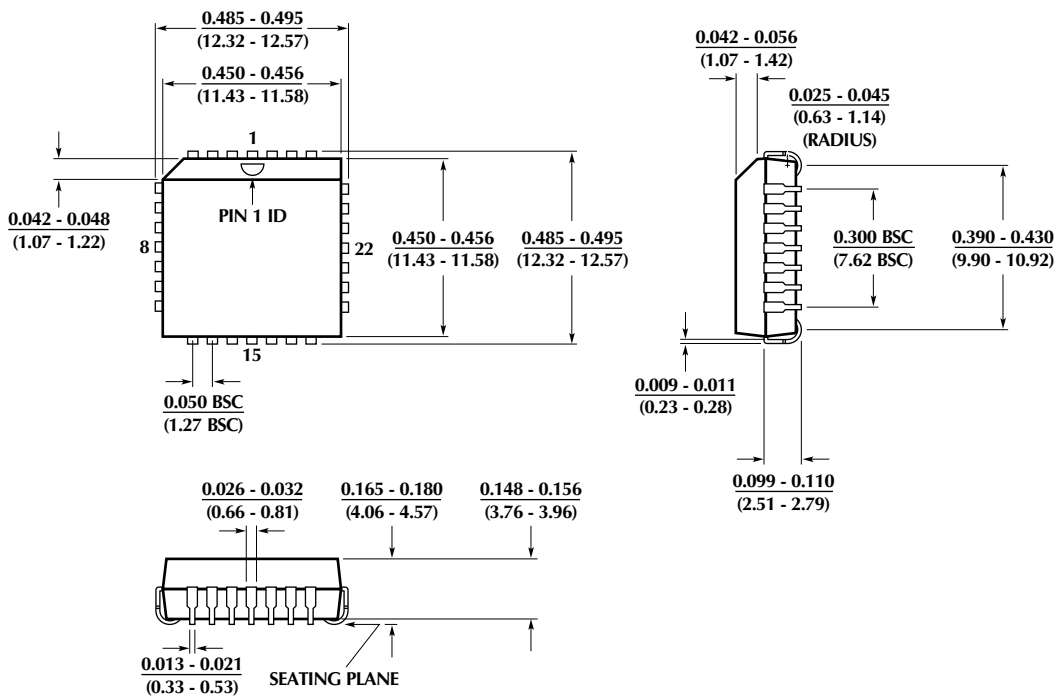

## ORDERING INFORMATION

PART NUMBER	TEMPERATURE RANGE	PACKAGE
ML4642CR	0°C to 70°C	28-Pin SSOP (R28)
ML4642CQ	0°C to 70°C	28-Pin PLCC (Q28)

© Micro Linear 1997.  **Micro Linear** is a registered trademark of Micro Linear Corporation. Products described in this document may be covered by one or more of the following patents, U.S.: 4,897,611; 4,964,026; 5,027,116; 5,281,862; 5,283,483; 5,418,502; 5,508,570; 5,510,727; 5,523,940; 5,546,017; 5,559,470; 5,565,761; 5,592,128; 5,594,376; Japan: 2598946; 2619299. Other patents are pending.

Micro Linear reserves the right to make changes to any product herein to improve reliability, function or design. Micro Linear does not assume any liability arising out of the application or use of any product described herein, neither does it convey any license under its patent right nor the rights of others. The circuits contained in this data sheet are offered as possible applications only. Micro Linear makes no warranties or representations as to whether the illustrated circuits infringe any intellectual property rights of others, and will accept no responsibility or liability for use of any application herein. The customer is urged to consult with appropriate legal counsel before deciding on a particular application.

2092 Concourse Drive  
San Jose, CA 95131  
Tel: 408/433-5200  
Fax: 408/432-0295

DS4642-01