

IS61LV12816

128K x 16 HIGH-SPEED CMOS STATIC RAM WITH 3.3V SUPPLY

NOVEMBER 2000

FEATURES

- High-speed access time: 8, 10, 12, and 15 ns
- CMOS low power operation
- TTL and CMOS compatible interface levels
- Single 3.3V \pm 10% power supply
- Fully static operation: no clock or refresh required
- Three state outputs
- Data control for upper and lower bytes
- Industrial temperature available

DESCRIPTION

The *ISSI* IS61LV12816 is a high-speed, 2,097,152-bit static RAM organized as 131,072 words by 16 bits. It is fabricated using *ISSI*'s high-performance CMOS technology. This highly reliable process coupled with innovative circuit design techniques, yields access times as fast as 8 ns with low power consumption.

When \overline{CE} is HIGH (deselected), the device assumes a standby mode at which the power dissipation can be reduced down with CMOS input levels.

Easy memory expansion is provided by using Chip Enable and Output Enable inputs, \overline{CE} and \overline{OE} . The active LOW Write Enable (\overline{WE}) controls both writing and reading of the memory. A data byte allows Upper Byte (\overline{UB}) and Lower Byte (\overline{LB}) access.

The IS61LV12816 is packaged in the JEDEC standard 44-pin 400-mil SOJ, 44-pin TSOP, 44-pin LQFP, and 48-pin mini BGA (6mm x 8mm).

FUNCTIONAL BLOCK DIAGRAM

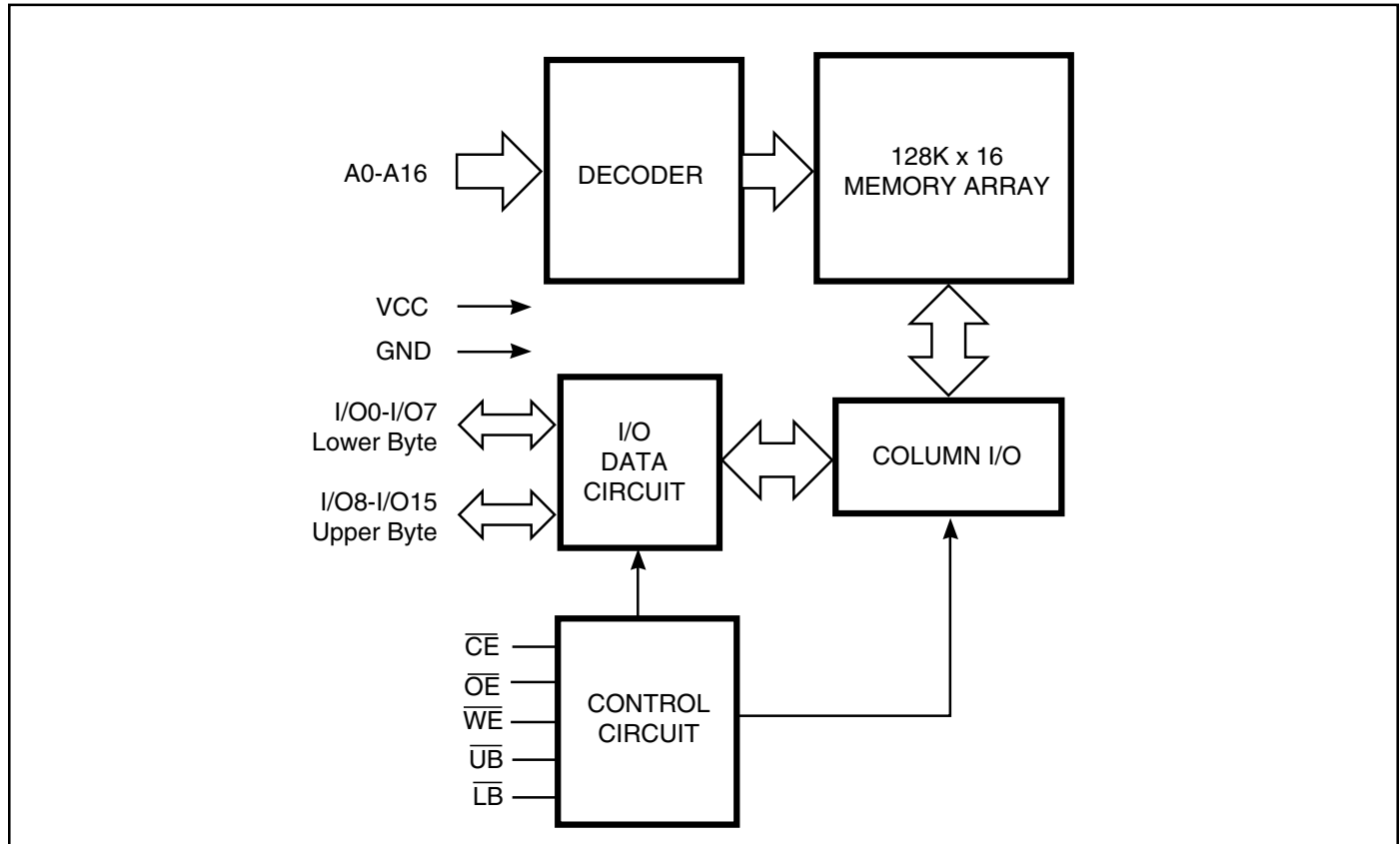

ISSI reserves the right to make changes to its products at any time without notice in order to improve design and supply the best possible product. We assume no responsibility for any errors which may appear in this publication. © Copyright 2000, Integrated Silicon Solution, Inc.

IS61LV12816

PIN CONFIGURATIONS

44-Pin SOJ (K)

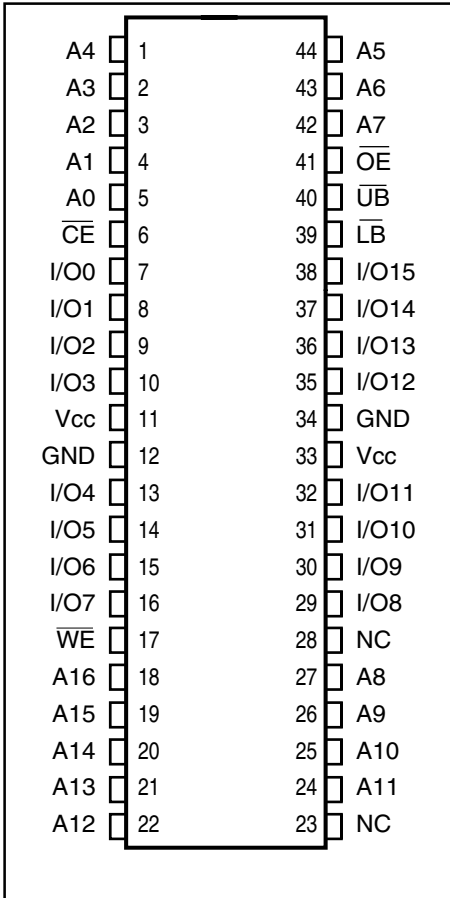

44-Pin TSOP (T)

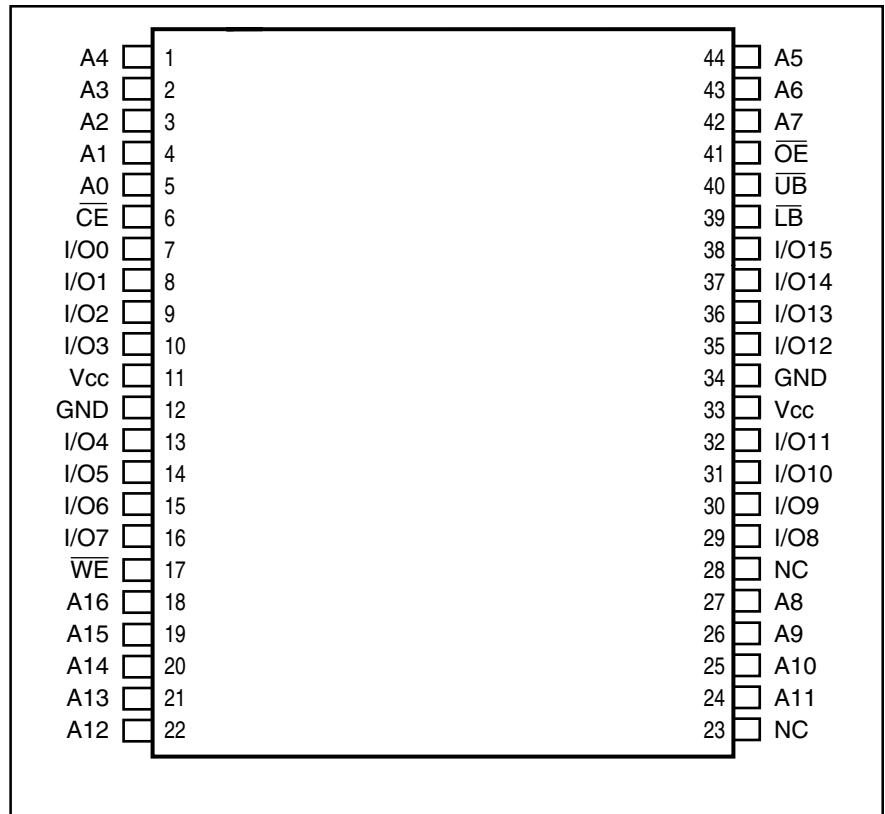

48-Pin mini BGA (B)

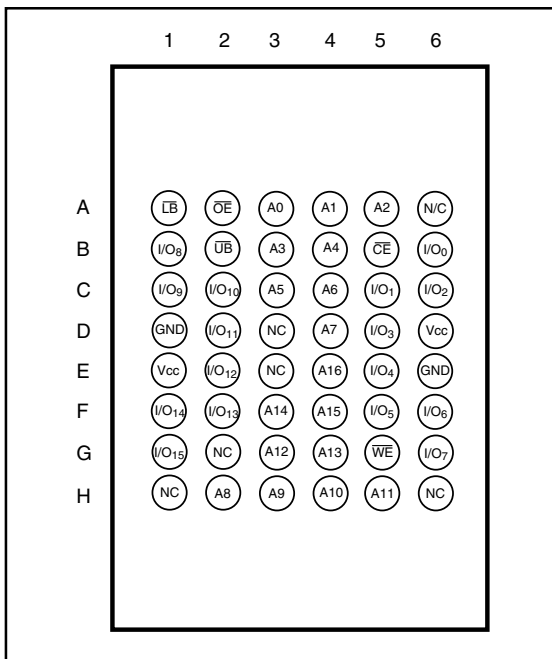

44-Pin LQFP (LQ)

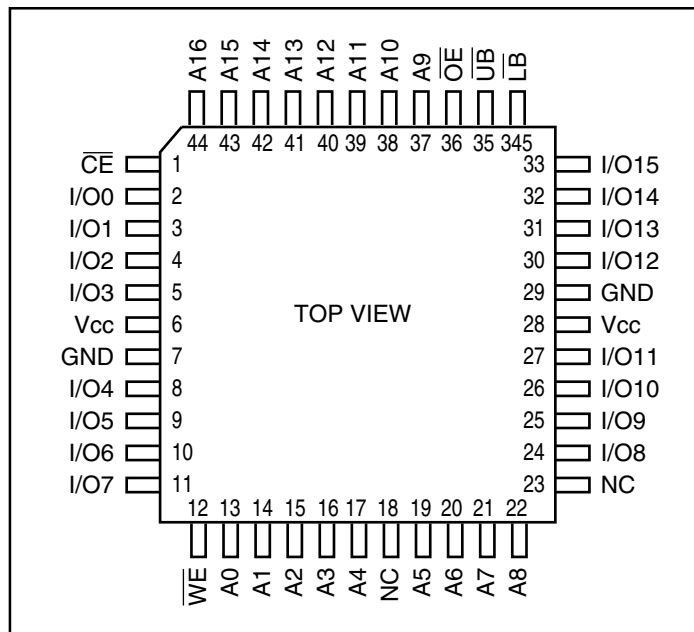

IS61LV12816

PIN DESCRIPTIONS

A0-A16	Address Inputs
I/O0-I/O15	Data Inputs/Outputs
\overline{CE}	Chip Enable Input
\overline{OE}	Output Enable Input
\overline{WE}	Write Enable Input
\overline{LB}	Lower-byte Control (I/O0-I/O7)
\overline{UB}	Upper-byte Control (I/O8-I/O15)
NC	No Connection
Vcc	Power
GND	Ground

OPERATING RANGE

Range	Ambient Temperature	Vcc
Commercial	0°C to + 70°C	3.3V ± 10%
Industrial	-40°C to + 85°C	3.3V ± 10%

ABSOLUTE MAXIMUM RATINGS⁽¹⁾

Symbol	Parameter	Value	Unit	
Vcc	Power Supply Voltage Relative to GND	-0.5 to 5.0	V	
VTERM	Terminal Voltage with Respect to GND	-0.5 to Vcc + 0.5	V	
TSTG	Storage Temperature	-65 to + 150	°C	
TBIAS	Temperature Under Bias:	Com.	-10 to + 85	°C
		Ind.	-45 to + 90	°C
PT	Power Dissipation	2.0	W	
IOUT	DC Output Current	±20	mA	

Note:

1. Stress greater than those listed under ABSOLUTE MAXIMUM RATINGS may cause permanent damage to the device. This is a stress rating only and functional operation of the device at these or any other conditions above those indicated in the operational sections of this specification is not implied. Exposure to absolute maximum rating conditions for extended periods may affect reliability.

DC ELECTRICAL CHARACTERISTICS (Over Operating Range)

Symbol	Parameter	Test Conditions	Min.	Max.	Unit
VOH	Output HIGH Voltage	Vcc = Min., IOH = -4.0 mA	2.4	—	V
VOL	Output LOW Voltage	Vcc = Min., IOL = 8.0 mA	—	0.4	V
VIH	Input HIGH Voltage ⁽¹⁾		2	Vcc + 0.3	V
VIL	Input LOW Voltage ⁽¹⁾		-0.3	0.8	V
ILI	Input Leakage	GND - VIN - Vcc	-1	1	µA
ILO	Output Leakage	GND - VOUT - Vcc, Outputs Disabled	-1	1	µA

Note:

1. VIL (min.) = -0.3V DC; VIL (min.) = -2.0V AC (pulse width - 2.0 ns).
VIH (max.) = Vcc + 0.3V DC; VIH (max.) = Vcc + 2.0V AC (pulse width - 2.0 ns).

TRUTH TABLE

Mode	\overline{WE}	\overline{OE}	\overline{OE}	\overline{LB}	\overline{UB}	I/O PIN		Vcc Current
						I/O0-I/O7	I/O8-I/O15	
Not Selected	X	H	X	X	X	High-Z	High-Z	ISB1, ISB2
Output Disabled	H	L	H	X	X	High-Z	High-Z	Icc
	X	L	X	H	H	High-Z	High-Z	
Read	H	L	L	L	H	DOUT	High-Z	Icc
	H	L	L	H	L	High-Z	DOUT	
	H	L	L	L	L	DOUT	DOUT	
Write	L	L	X	L	H	DIN	High-Z	Icc
	L	L	X	H	L	High-Z	DIN	
	L	L	X	L	L	DIN	DIN	

POWER SUPPLY CHARACTERISTICS⁽¹⁾ (Over Operating Range)

Symbol	Parameter	Test Conditions	-8 ns		-10 ns		-12 ns		-15 ns		Unit	
			Min.	Max.	Min.	Max.	Min.	Max.	Min.	Max.		
Icc	Vcc Operating Supply Current	Vcc = Max., $\overline{CE} = V_{IL}$	Com.	—	150	—	125	—	110	—	90	mA
		I _{OUT} = 0 mA, f = Max.	Ind.	—	160	—	135	—	120	—	100	
ISB1	TTL Standby Current (TTL Inputs)	Vcc = Max.,	Com.	—	50	—	40	—	35	—	30	mA
		V _{IN} = V _{IH} or V _{IL} $\overline{CE} \cdot V_{IH}$, f = max	Ind.	—	60	—	50	—	45	—	40	
ISB2	CMOS Standby Current (CMOS Inputs)	Vcc = Max.,	Com.	—	10	—	10	—	10	—	10	mA
		$\overline{CE} - V_{CC} - 0.2V$, V _{IN} > V _{CC} - 0.2V, or V _{IN} - 0.2V, f = 0	Ind.	—	20	—	20	—	20	—	20	

Note:

1. At f = f_{MAX}, address and data inputs are cycling at the maximum frequency, f = 0 means no input lines change.

IS61LV12816

CAPACITANCE⁽¹⁾

Symbol	Parameter	Conditions	Max.	Unit
C _{IN}	Input Capacitance	V _{IN} = 0V	6	pF
C _{OUT}	Input/Output Capacitance	V _{OUT} = 0V	8	pF

Note:

1. Tested initially and after any design or process changes that may affect these parameters.

READ CYCLE SWITCHING CHARACTERISTICS⁽¹⁾ (Over Operating Range)

Symbol	Parameter	-8 ns		-10 ns		-12 ns		-15 ns		Unit
		Min.	Max.	Min.	Max.	Min.	Max.	Min.	Max.	
t _{RC}	Read Cycle Time	8	—	10	—	12	—	15	—	ns
t _{AA}	Address Access Time	—	8	—	10	—	12	—	15	ns
t _{OH}	Output Hold Time	3	—	3	—	3	—	3	—	ns
t _{ACE}	\overline{CE} Access Time	8	—	—	10	—	12	—	15	ns
t _{DOE}	\overline{OE} Access Time	—	3	—	4	—	5	—	6	ns
t _{HZOE} ⁽²⁾	\overline{OE} to High-Z Output	—	3	—	4	—	5	0	6	ns
t _{LZOE} ⁽²⁾	\overline{OE} to Low-Z Output	0	—	0	—	0	—	0	—	ns
t _{HZCE} ⁽²⁾	\overline{CE} to High-Z Output	0	3	0	4	0	5	0	8	ns
t _{LZCE} ⁽²⁾	\overline{CE} to Low-Z Output	3	—	3	—	3	—	3	—	ns
t _{BA}	\overline{LB} , \overline{UB} Access Time	—	3	—	4	—	5	—	6	ns
t _{HZB} ⁽²⁾	\overline{LB} , \overline{UB} to High-Z Output	0	3	0	4	0	5	0	6	ns
t _{LZB} ⁽²⁾	\overline{LB} , \overline{UB} to Low-Z Output	0	—	0	—	0	—	0	—	ns

Notes:

1. Test conditions assume signal transition times of 3 ns or less, timing reference levels of 1.5V, input pulse levels of 0V to 3.0V and output loading specified in Figure 1.
2. Tested with the load in Figure 2. Transition is measured ±500 mV from steady-state voltage. Not 100% tested.

AC TEST CONDITIONS

Parameter	Unit
Input Pulse Level	0V to 3.0V
Input Rise and Fall Times	3 ns
Input and Output Timing and Reference Level	1.5V
Output Load	See Figures 1 and 2

AC TEST LOADS

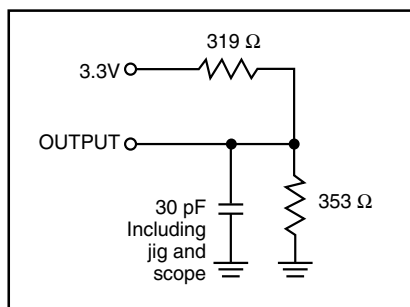

Figure 1.

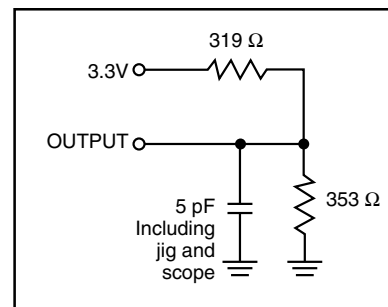
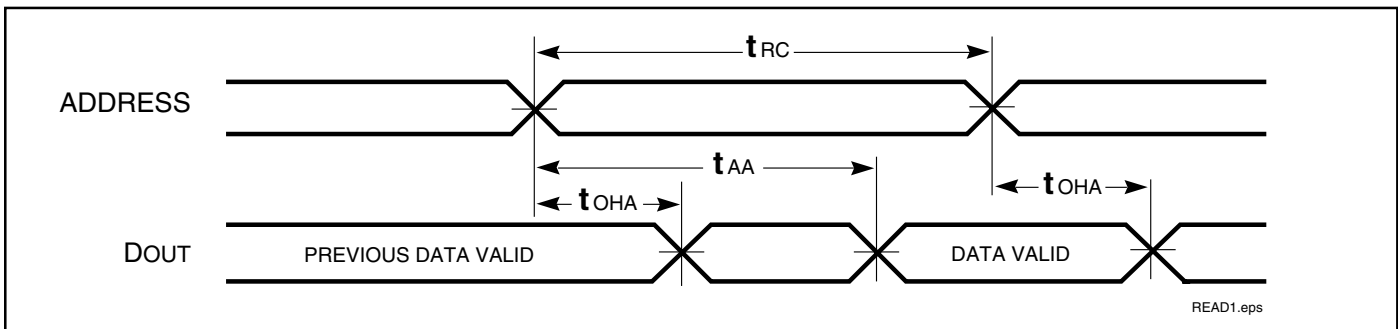

Figure 2.

AC WAVEFORMS

READ CYCLE NO. 1^(1,2) (Address Controlled) ($\overline{CE} = \overline{OE} = V_{IL}$, \overline{UB} or $\overline{LB} = V_{IL}$)



READ CYCLE NO. 2^(1,3)

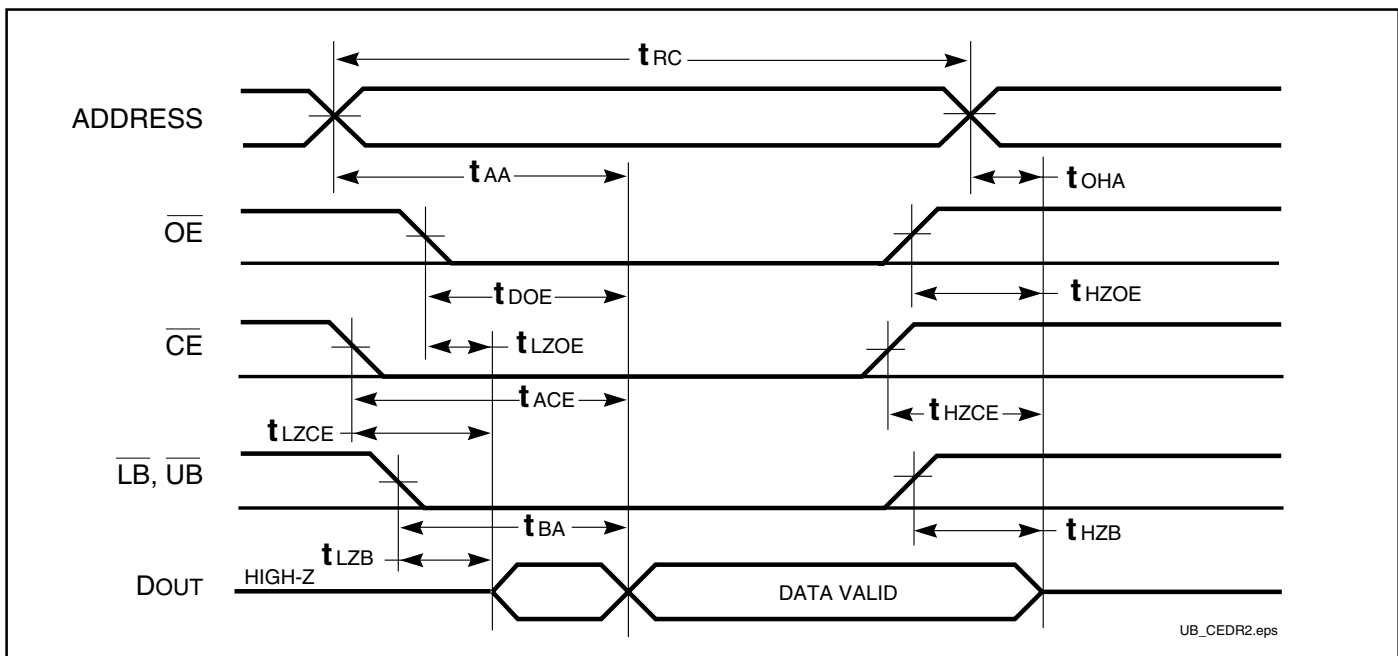

Notes:

1. \overline{WE} is HIGH for a Read Cycle.
2. The device is continuously selected. \overline{OE} , \overline{CE} , \overline{UB} , or $\overline{LB} = V_{IL}$.
3. Address is valid prior to or coincident with \overline{CE} LOW transition.

WRITE CYCLE SWITCHING CHARACTERISTICS^(1,3) (Over Operating Range)

Symbol	Parameter	-8 ns		-10 ns		-12 ns		-15 ns		Unit
		Min.	Max.	Min.	Max.	Min.	Max.	Min.	Max.	
t _{WC}	Write Cycle Time	8	—	10	—	12	—	15	—	ns
t _{SCE}	\overline{CE} to Write End	6.5	—	8	—	8	—	10	—	ns
t _{AW}	Address Setup Time to Write End	6.5	—	8	—	8	—	10	—	ns
t _{HA}	Address Hold from Write End	0	—	0	—	0	—	0	—	ns
t _{SA}	Address Setup Time	0	—	0	—	0	—	0	—	ns
t _{PWB}	\overline{LB} , \overline{UB} Valid to End of Write	6.5	—	8	—	9	—	10	—	ns
t _{PWE1}	\overline{WE} Pulse Width (\overline{OE} = HIGH)	5	—	7	—	8	—	10	—	ns
t _{PWE2}	\overline{WE} Pulse Width (\overline{OE} = LOW)	6.5	—	8	—	10	—	11	—	ns
t _{SD}	Data Setup to Write End	4	—	5	—	6	—	7	—	ns
t _{HD}	Data Hold from Write End	0	—	0	—	0	—	0	—	ns
t _{HZWE⁽³⁾}	\overline{WE} LOW to High-Z Output	—	3	—	4	—	5	—	6	ns
t _{LZWE⁽³⁾}	\overline{WE} HIGH to Low-Z Output	0	—	0	—	0	—	0	—	ns

Notes:

1. Test conditions assume signal transition times of 3 ns or less, timing reference levels of 1.5V, input pulse levels of 0V to 3.0V and output loading specified in Figure 1.
2. The internal write time is defined by the overlap of \overline{CE} LOW and \overline{UB} or \overline{LB} , and \overline{WE} LOW. All signals must be in valid states to initiate a Write, but any one can go inactive to terminate the Write. The Data Input Setup and Hold timing are referenced to the rising or falling edge of the signal that terminates the write.
3. Tested with the load in Figure 2. Transition is measured ± 500 mV from steady-state voltage. Not 100% tested.

WRITE CYCLE NO. 1^(1,2) (\overline{CE} Controlled, \overline{OE} = HIGH or LOW)

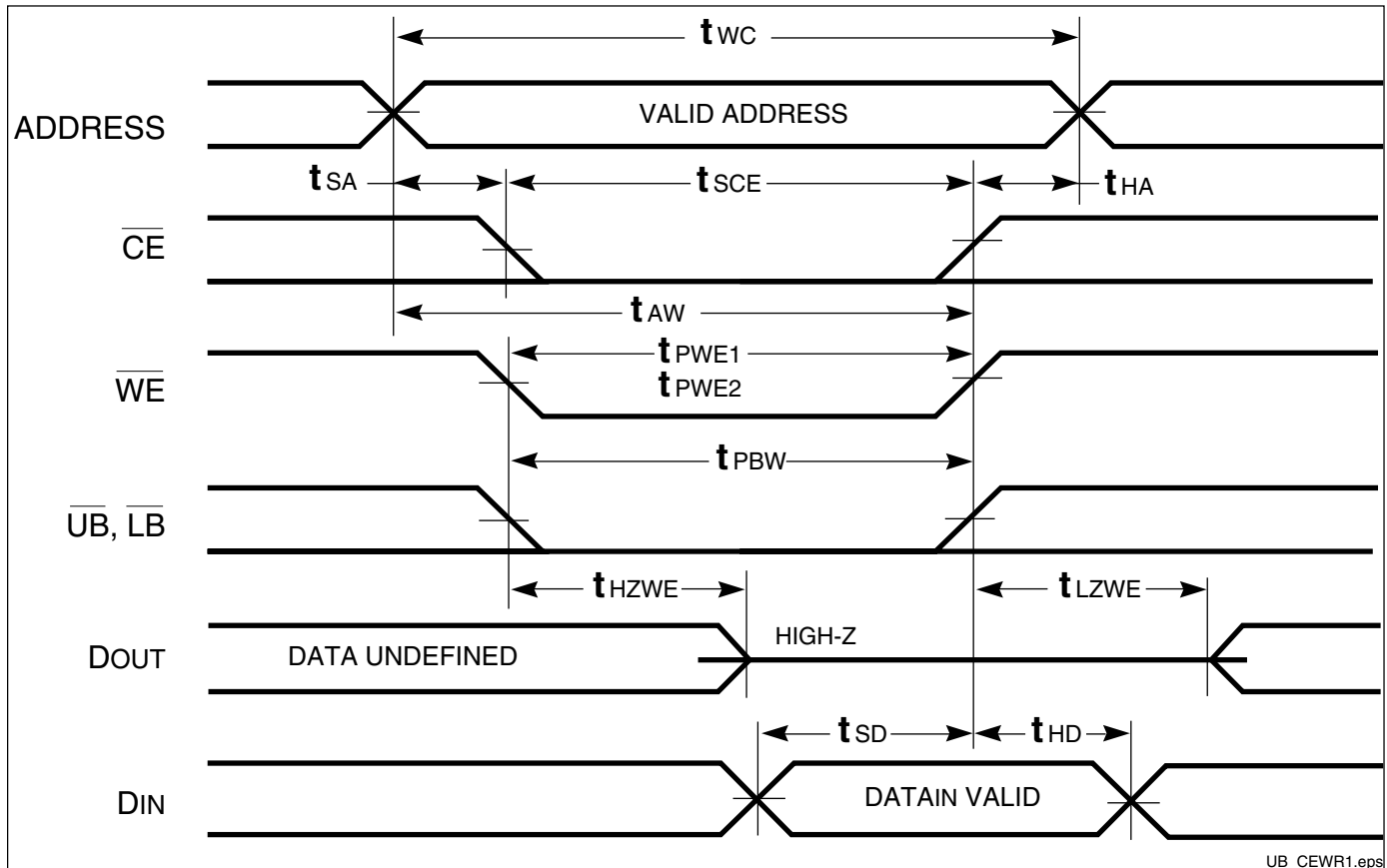

WRITE CYCLE NO. 2⁽¹⁾ (\overline{WE} Controlled, \overline{OE} = HIGH during Write Cycle)

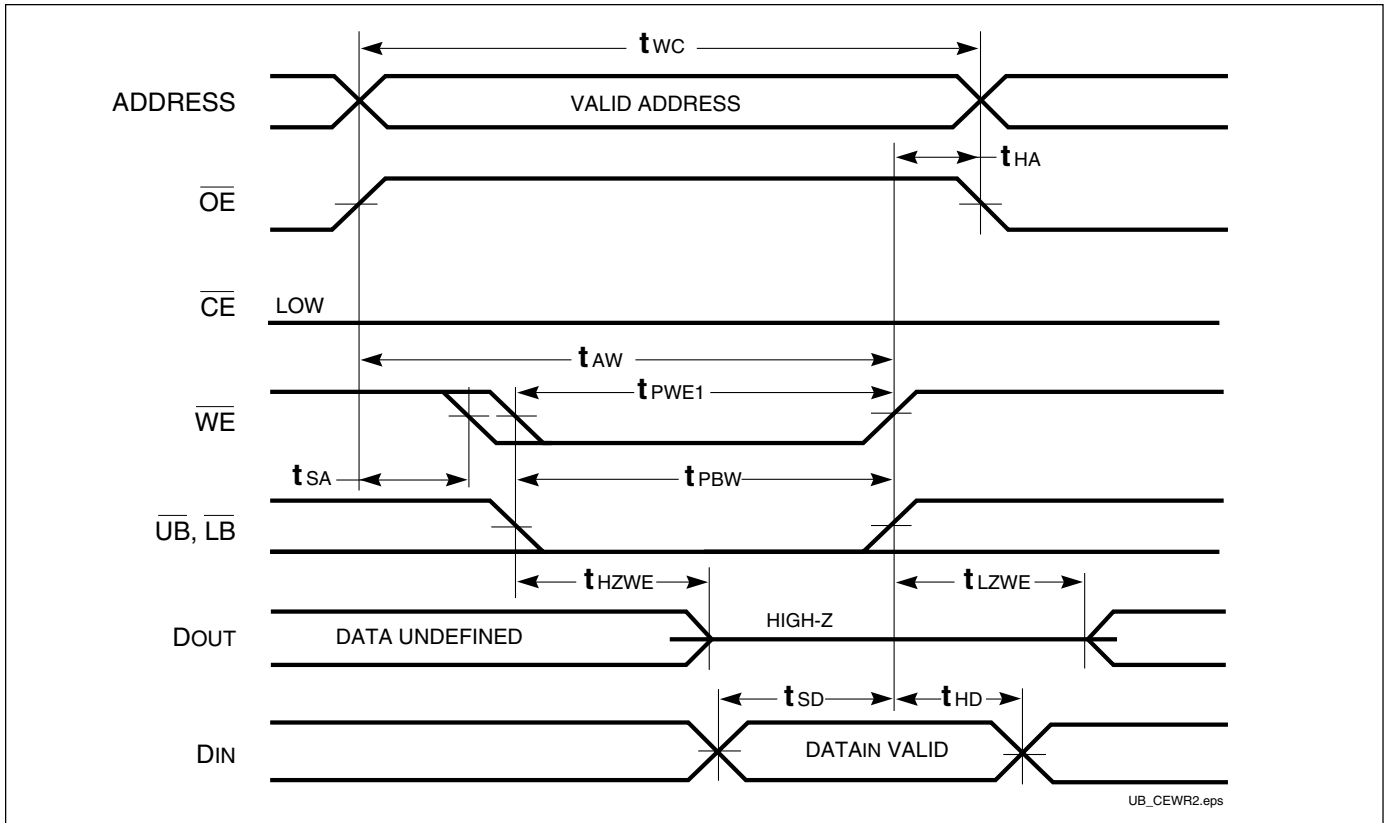

WRITE CYCLE NO. 3 (\overline{WE} Controlled: \overline{OE} is LOW During Write Cycle)

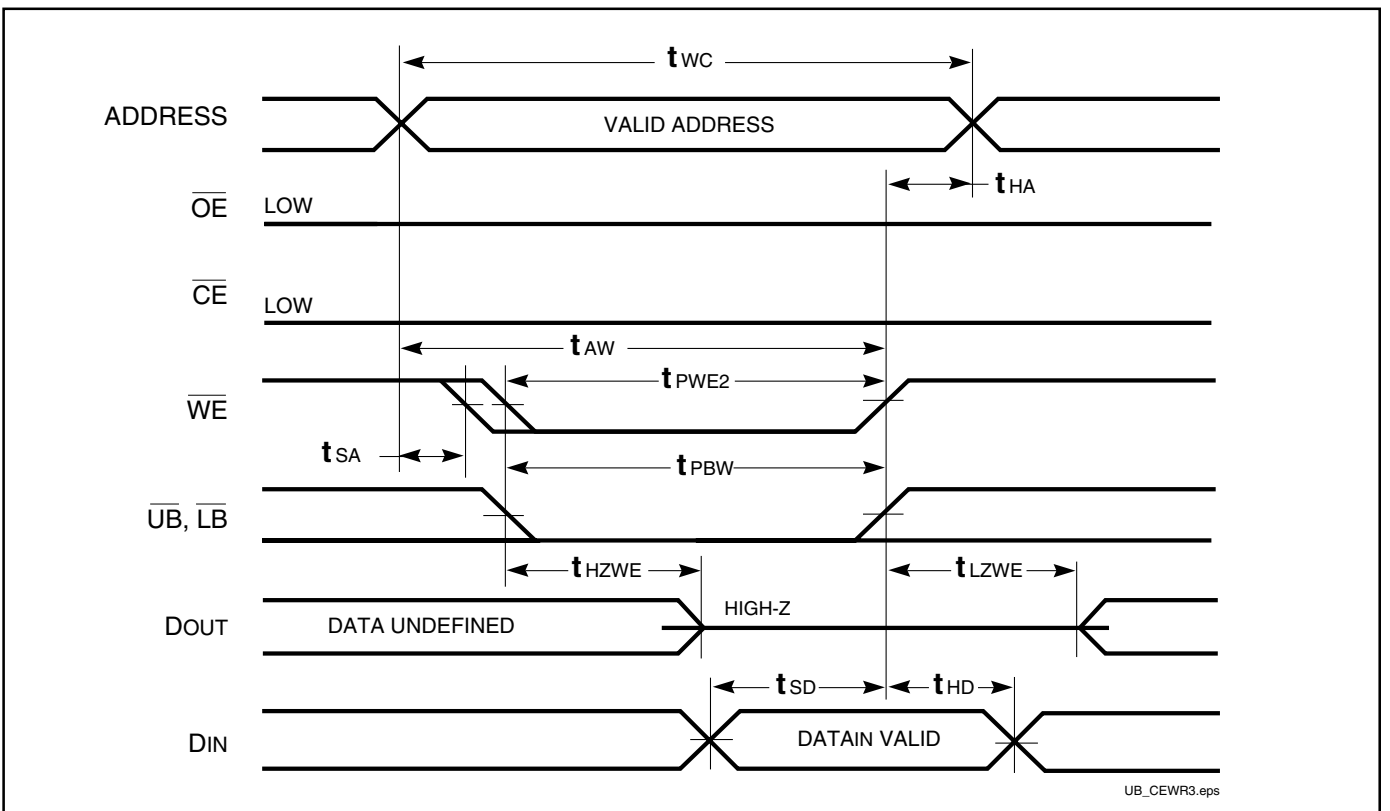

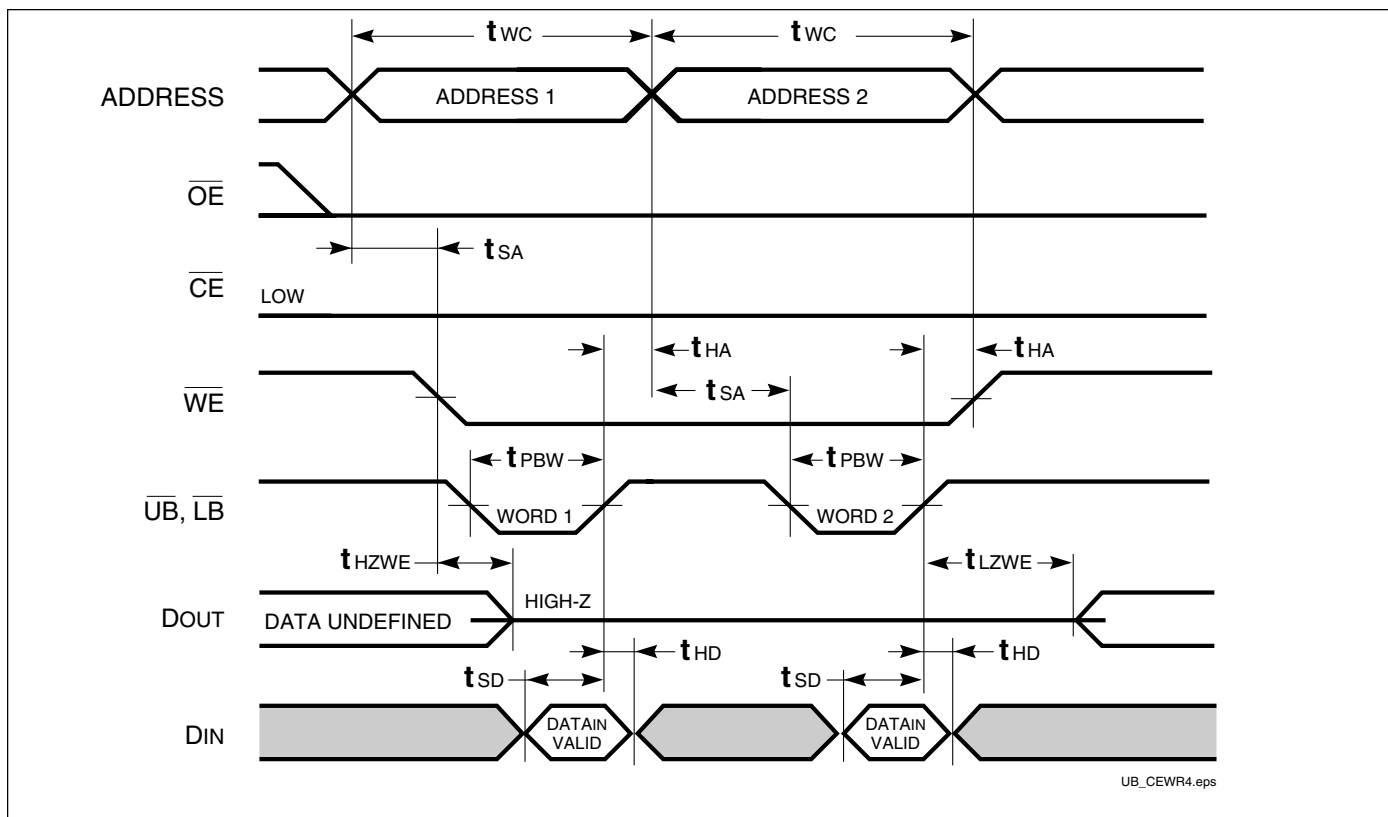
WRITE CYCLE NO. 4 ($\overline{\text{LB}}$, $\overline{\text{UB}}$ Controlled, Back-to-Back Write) ^(1,3)**Notes:**

1. The internal Write time is defined by the overlap of $\overline{\text{CE}} = \text{LOW}$, $\overline{\text{UB}}$ and/or $\overline{\text{LB}} = \text{LOW}$, and $\overline{\text{WE}} = \text{LOW}$. All signals must be in valid states to initiate a Write, but any can be deasserted to terminate the Write. The t_{SA} , t_{HA} , t_{SD} , and t_{HD} timing is referenced to the rising or falling edge of the signal that terminates the Write.
2. Tested with $\overline{\text{OE}}$ HIGH for a minimum of 4 ns before $\overline{\text{WE}} = \text{LOW}$ to place the I/O in a HIGH-Z state.
3. $\overline{\text{WE}}$ may be held LOW across many address cycles and the $\overline{\text{LB}}$, $\overline{\text{UB}}$ pins can be used to control the Write function.

**IS61LV12816 STANDARD VERSION
ORDERING INFORMATION**
Commercial Range: 0°C to +70°C

Speed (ns)	Order Part No.	Package
8	IS61LV12816-8B	mini BGA (6mm x 8mm)
	IS61LV12816-8K	400-mil Plastic SOJ
	IS61LV12816-8LQ	LQFP
	IS61LV12816-8T	Plastic TSOP
10	IS61LV12816-10B	mini BGA (6mm x 8mm)
	IS61LV12816-10K	400-mil Plastic SOJ
	IS61LV12816-10LQ	LQFP
	IS61LV12816-10T	Plastic TSOP
12	IS61LV12816-12B	mini BGA (6mm x 8mm)
	IS61LV12816-12K	400-mil Plastic SOJ
	IS61LV12816-12LQ	LQFP
	IS61LV12816-12T	Plastic TSOP
15	IS61LV12816-15B	mini BGA (6mm x 8mm)
	IS61LV12816-15K	400-mil Plastic SOJ
	IS61LV12816-15LQ	LQFP
	IS61LV12816-15T	Plastic TSOP

**IS61LV12816 STANDARD VERSION
ORDERING INFORMATION**
Industrial Range: -40°C to +85°C

Speed (ns)	Order Part No.	Package
8	IS61LV12816-8BI	mini BGA (6mm x 8mm)
	IS61LV12816-8KI	400-mil Plastic SOJ
	IS61LV12816-8LQI	LQFP
	IS61LV12816-8TI	Plastic TSOP
10	IS61LV12816-10BI	mini BGA (6mm x 8mm)
	IS61LV12816-10KI	400-mil Plastic SOJ
	IS61LV12816-10LQI	LQFP
	IS61LV12816-10TI	Plastic TSOP
12	IS61LV12816-12BI	mini BGA (6mm x 8mm)
	IS61LV12816-12KI	400-mil Plastic SOJ
	IS61LV12816-12LQI	LQFP
	IS61LV12816-12TI	Plastic TSOP
15	IS61LV12816-15BI	mini BGA (6mm x 8mm)
	IS61LV12816-15KI	400-mil Plastic SOJ
	IS61LV12816-15LQI	LQFP
	IS61LV12816-15TI	Plastic TSOP

Integrated Silicon Solution, Inc.

2231 Lawson Lane
 Santa Clara, CA 95054
 Tel: 1-800-379-4774
 Fax: (408) 588-0806
 E-mail: sales@issi.com
www.issi.com