

HD VIDEO/ GRAPHICS UMA SUBSYSTEM AND MIXER WITH DVI

BCM7035 FEATURES

- **ATSC-compliant, All-Format MP@HL MPEG-2 video dual decoder with personal video recording feature**
 - Dual channel decode with simultaneous standard definition (SD) display of each channel content
 - Single channel high definition (HD) decode with simultaneous display of both HD and scaled SD content
 - Simultaneous dual record, dual playback personal video recording (PVR) with encryption
 - Six on-chip video DACs
 - DVD playback
- **Dolby Digital (AC-3)/MPEG multichannel audio decoder with SPDIF output**
- **Stereo audio DACs**
- **Fully featured 3D graphics hardware accelerator**
- **NTSC/PAL analog video decoder**
- **NTSC/PAL/HD video encoder**
- **Bus bridge to memory, local bus, and PCI**
- **POD support including DVS 213 DES descrambler**
- **DVT and DC2-compliant transport demultiplexer with DVB, DES, and Multi2 descramblers**
- **Support for 64 PIDs and 64 section filters**
- **24-bit digital HD video input port and internal mixer**

SUMMARY OF BENEFITS

- **Provides a cost-effective solution for high definition and standard definition video and graphics systems common to cable and satellite applications**
- **PVR capability enables personal viewing and scheduling, video-on-demand (VOD), and VCR trick-mode effects on any video stream**
 - **Encryption ensures copy protection of recorded programming content**
- **Includes simultaneous high definition and standard definition analog output for watch and record capability**
- **Advanced 2D graphics system allows applications such as internet browsers and electronic program guides to deliver studio-quality text and graphics on television monitors**
- **Fully featured 3D graphics engine allows for multi-player gaming and 3D internet website acceleration**
- **PCI interface allows for direct connection of cost-effective SuperI/O devices**
- **High-performance DMA capability can be used for cable modem traffic**
- **Broadcom-developed device drivers enable rapid software development cycle**
- **Supports DVS POD requirements**
- **Supports embedded HDTV applications**

BCM7035 Advanced Video, Graphics, and Audio Subsystem with Bus Bridge

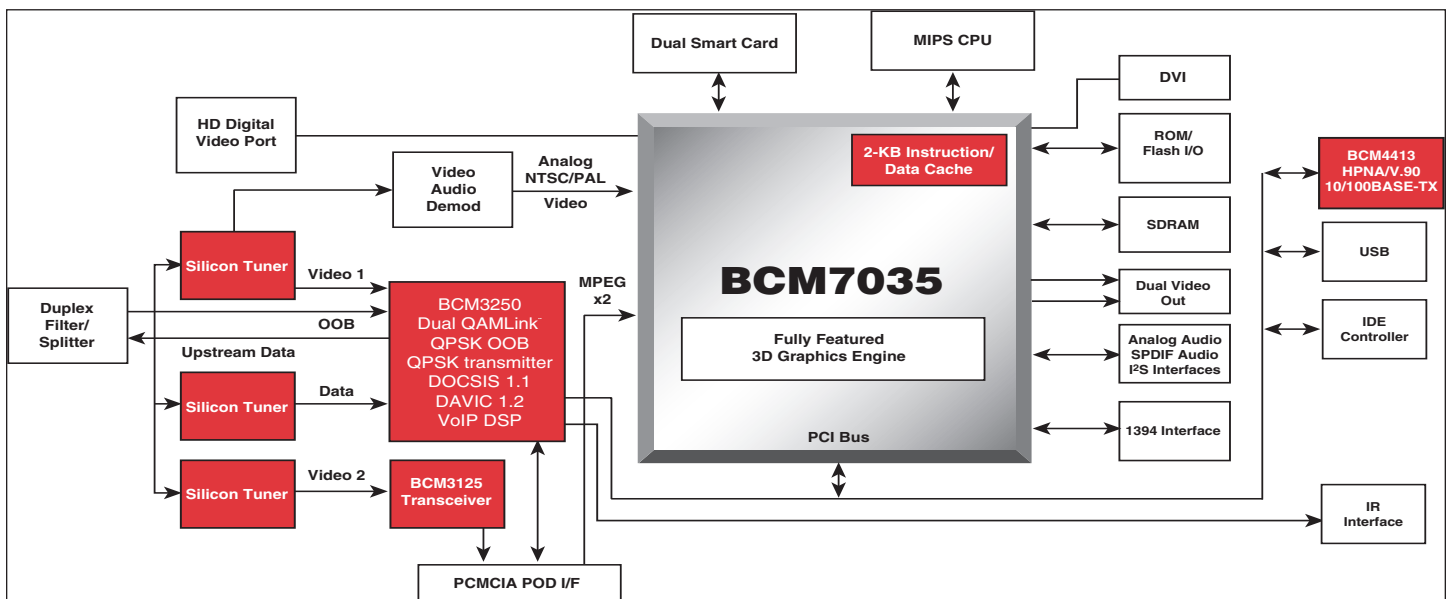

BCM7035 OVERVIEW

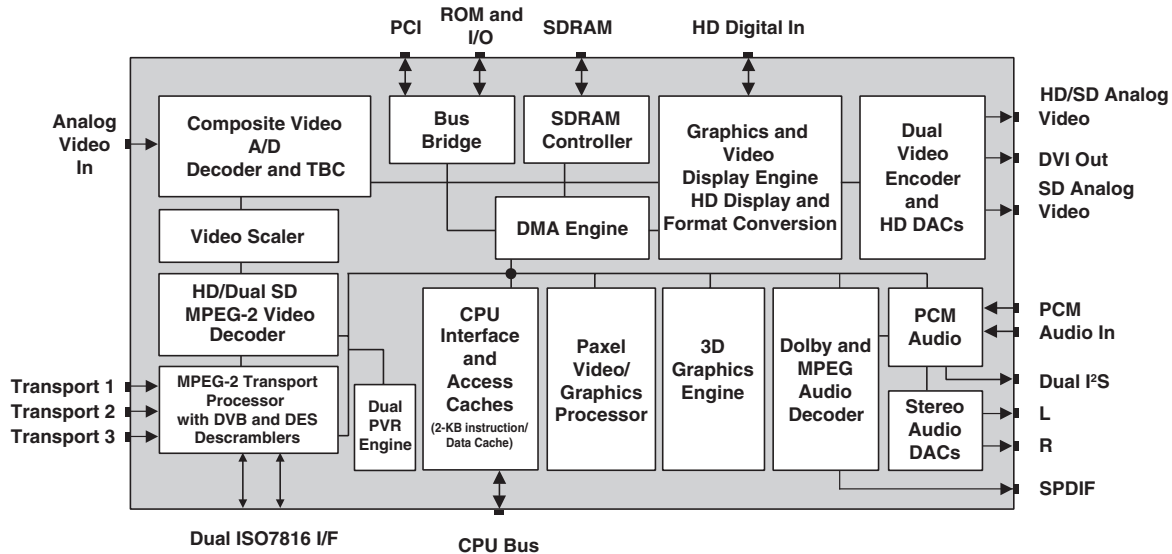

The **BCM7035** Advanced High Definition, Video/Graphics Subsystem supports the requirements of television and set-top box systems that require high definition or standard definition decoding of MPEG-2 streams with simultaneous high definition and standard definition outputs. For systems that require only standard-definition output, a reduced-memory mode substantially reduces the amount of memory needed for the video decompressions process. The video decoder also supports multiple stream standard definition decoding, providing both tiled video and PIP capability.

The **BCM7035** graphics are based on Broadcom's advanced video/graphics technology that allows studio-quality text and graphics to be displayed on television-based systems. The graphics compositing engine allows for many windows of graphics and video to be layered with blending and anti-aliasing, creating rich, high-quality, display capability.

An onboard vector RISC processor provides 2D graphics, anti-aliased text, and 3D effects.

A MPEG-2 DVB/DC2-compliant transport DEMUX with 3 transport stream inputs has advanced section filtering capability, DVB descrambler, DES descrambler with ECB/CCB capability, and 2 ISO7816 smart card interfaces. The DES descrambler complies with the DVS 213 requirements for the transport stream POD interface.

The transport engine is designed to support personal video recorder (PVR) functions, allowing the set-top box to support VCR-like

functions, such as fast forward/reverse, pause, and record. The **BCM7035** supports up to 2 record and 2 playback streams simultaneously, with optional 3DES encryption/decryption.

The **BCM7035** decodes both Dolby Digital (AC-3) and MPEG multichannel compressed streams. Audio output is provided over stereo DACs or SPDIF.

A PCM audio engine mixes separate audio streams generated from the MPEG2/Dolby audio decompression circuitry, PCM audio generated from the CPU, or PCM audio input via a baseband audio input. These streams can be resampled and mixed together with volume control.

A bus bridge is incorporated to provide a complete solution bridging the processor to memory, local I/O, and PCI. Main memory is shared among video, graphics, and the CPUs, which increases system performance and reduces cost. A flexible and powerful DMA controller offloads the CPU by transferring data between the different busses and memory, facilitating the needs of systems incorporating a cable modem.

DVD playback is realizable. The on-chip MPEG video decoder has the ability to parse the PES streams extracted from the program streams found on DVDs. AC-3 audio can be decoded to either stereo or Dolby ProLogic and output to either the on-chip DAC and/or as PCM to the SPDIF interface. The audio engine can also output native AC-3 or DTS bit streams directly to the SPDIF. Sub-picture decoding and rendering are handled by the host CPU and the on-chip graphics processor. With the assistance of software running on an external CPU, a complete DVD playback system can be realized.

Broadcom®, the pulse logo, and Connecting everything® are trademarks of Broadcom Corporation and/or its subsidiaries in the United States and certain other countries. All other trademarks are the property of their respective owners.

Connecting
everything®



BROADCOM CORPORATION
16215 Alton Parkway, P.O. Box 57013
Irvine, California 92619-7013

© 2002 by BROADCOM CORPORATION. All rights reserved.
7035-PB03-403-R 11.19.02

Phone: 949-450-8700
FAX: 949-450-8710
Email: info@broadcom.com
Web: www.broadcom.com