

## BCM5700 PCI-X 10/100/1000BASE-T CONTROLLER

### BCM5700 FEATURES

- 10/100/1000 Mbps tri-speed media access controller (MAC) with wire speed performance at all rates
- Support for PCI v2.2, 32/64-bit, 33/66 MHz, and PCI-X v1.0 32/64-bit, 66/133-MHz bus interfaces
- 96 KB ultra-deep packet buffer with support for up to 16 MB externally
- Support for IEEE 802.3, 802.3u, 802.3z, and 802.3ab standards
- MII/GMII and TBI (SerDes style) transceiver interfaces
- Advanced CPU offload features include: TCP/UDP/IP checksum offload, TCP segmentation, 9 KB jumbo frame
- Dual high-speed CPUs
- Microsoft® PC99 compliant: support for ACPI ver 1.1a, Wake on LAN, PXE version 2.0, and statistics for SNMP MIB II, Ethernet-like MIB, and Ethernet MIB (802.3z, Clause 30)
- Layer 2 priority encoding (802.3p) (up to 16 priority queues)
- VLAN tagging (IEEE 802.3q)
- Flow control (IEEE 802.3x)
- Link aggregation (IEEE802.3ad)
- Multiple power modes with programmable low power operation
- Low power design – 3.3 V/1.8 V, 0.18  $\mu$ m CMOS
- 5V tolerant PCI I/Os
- 388-pin PBGA package

### SUMMARY OF BENEFITS

- Features wire speed operation at all speeds.
- The BCM5700 is ideal for new high-speed network interface cards (NIC) and LAN on Motherboard (LOM) applications, while maintaining backward compatibility with today's networks.
- Support for both the PCI 2.2 and PCI-X standard enables the BCM5700 to run in any PCI-based or PCI-X systems.
- The ultra-deep on-chip packet buffer allows the BCM5700 to continuously transmit and receive at high speeds in systems where the PCI/PCI-X bus is shared with other devices.
- On-chip CPUs perform advanced functions and allow the BCM5700 to evolve with new standards. The CPUs also provide advanced packet parsing capabilities, making the BCM5700 an OSI L4 protocol aware device, providing many advanced features and offloads.
- Advanced offload features promote high throughput, while minimizing host CPU utilization.
- Combined with the BCM5401 and newer Broadcom 10/100/1000BASE-T PHYs, the BCM5700 supports ACPI-compliant Wake on LAN implementations.
- Additional manageability features enable NIC and LOM designs to comply with relevant manageability standards for server and desktop applications.
- Provides low power operation—0.18  $\mu$ m advanced process technology, combined with programmable power management.

### BCM5700 10/100/1000 PCI-X NIC Reference Design

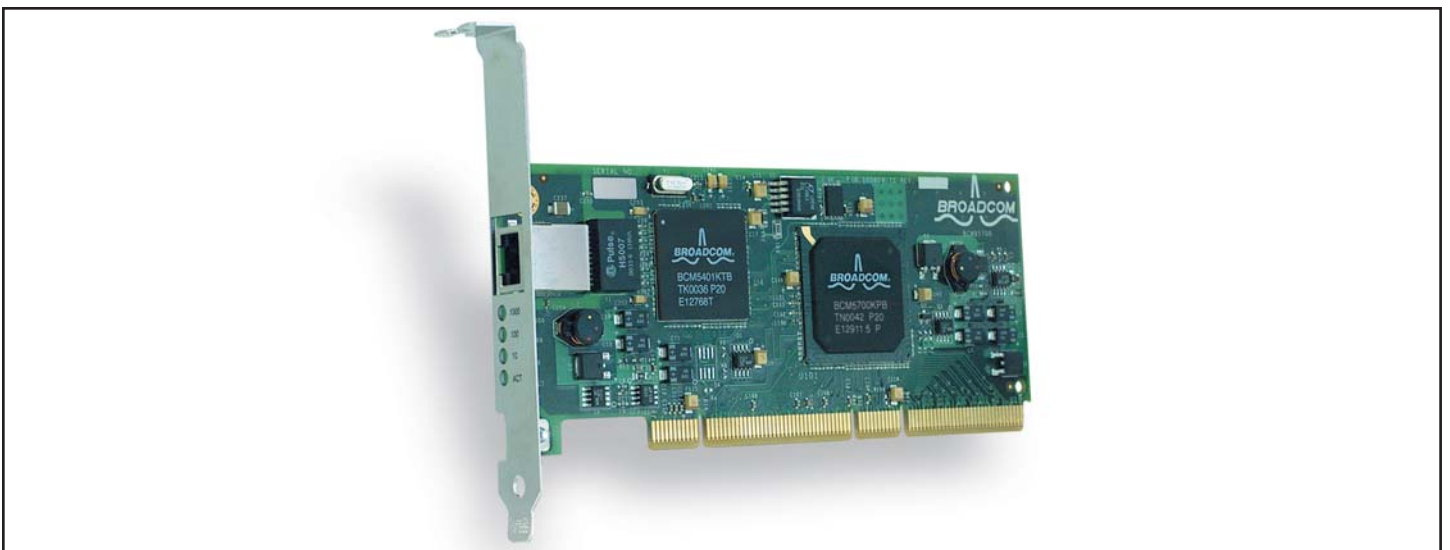

# BCM5700 OVERVIEW

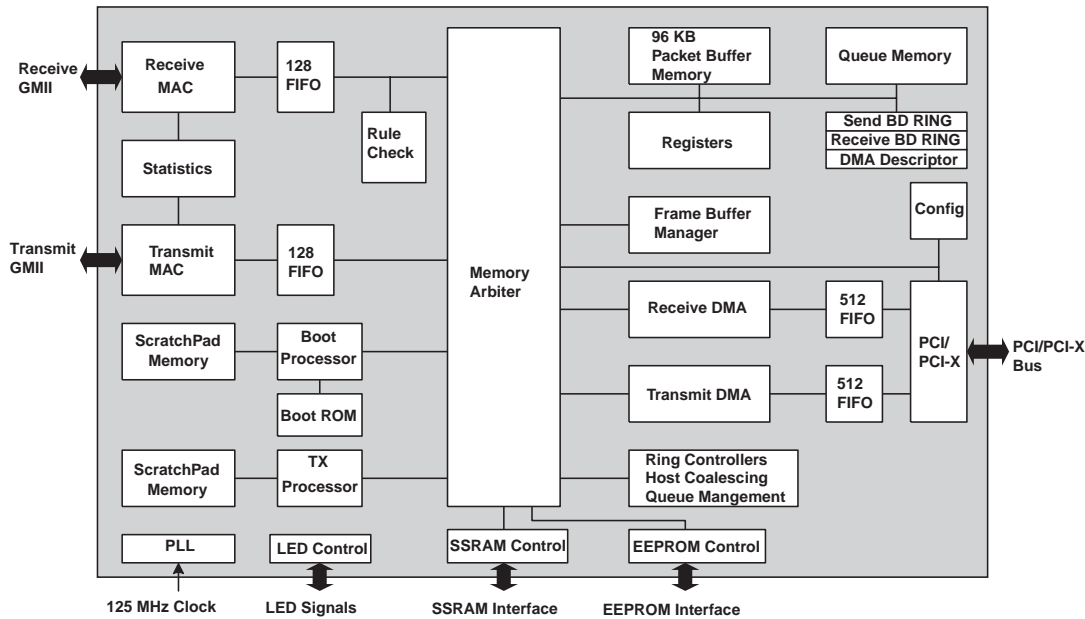

The **BCM5700** is a high-performance 10/100/1000BASE-T Ethernet LAN controller optimized for NIC and LOM applications. The **BCM5700** is a highly-integrated solution combining 10/100/1000BASE-T IEEE 802.3 compliant media access controller (MAC), PCI and PCI-X bus interfaces, and on-chip buffer memory in a single device. The **BCM5700** is fabricated in a low voltage 1.8V CMOS process, providing a low-power system solution. Combine the **BCM5700** with the BCM5401 (or later) single-chip Gigabit Ethernet transceiver to achieve a complete NIC or LOM solution for 10/100/1000BASE-T Ethernet.

The **BCM5700** includes a 10/100/1000 Mbps Ethernet MAC with full/half-duplex capability at all speeds. The MAC interacts with the external transceiver via the GMII in 1000BASE-T mode, the MII in 10/100BASE-T mode, and the TBI serial interface in 1000BASE-SX/1000BASE-FX mode. Support for the following 802.3 packet tagging functions is featured in the MAC: VLAN tagging, layer 2 priority encoding, link aggregation, and full-duplex flow control.

The device provides both PCI v2.2, 32/64-bit, 33/66-MHz and PCI-X v1.0, 133-MHz, host interfaces. The **BCM5700** includes a 96 KB on-chip buffer memory for stand-alone operation, and

optionally supports up to 16 MB of external memory. Dual on-chip high-performance processors enable many custom frame processing features, including TCP segmentation.

## Target Applications of the BCM5700

Network Interface Card (NIC) designs		LAN on Motherboard (LOM) designs	
<b>Single Port</b>			
10/100/1000 BASE_T	PCI 2.2 Adapters PCI-X v1.0 Adapters	10/100/1000 BASE_T	PCI 2.2 LOM PCI-X v1.0 LOM
1000 BASE_SX	PCI 2.2 Adapters PCI-X v1.0 Adapters	<b>Dual Port</b>	
1000 BASE_LX	PCI 2.2 Adapters PCI-X v1.0 Adapters	10/100/1000 BASE_T	PCI 2.2 LOM PCI-X v1.0 LOM
<b>Dual Port</b>			
10/100/1000 BASE_T	PCI 2.2 Adapters PCI-X v1.0 Adapters		

## BCM5700 Operating System

- Microsoft® Windows® NT® 4.0
- Microsoft Windows 2000
- Linux™ 2.2
- NetWare® 4.11, 4.2 and 5.x
- Novell®

Broadcom®, the pulse logo and Connecting everything® are trademarks of Broadcom Corporation and/or its subsidiaries in the United States and certain other countries. All other trademarks are the property of their respective owners.

Connecting  
everything®



**BROADCOM CORPORATION**  
16215 Alton Parkway, P.O. Box 57013  
Irvine, California 92619-7013

© 2003 by BROADCOM CORPORATION. All rights reserved.  
5700-PB06-R 06.25.03

Phone: 949-450-8700  
FAX: 949-450-8710  
Email: info@broadcom.com  
Web: www.broadcom.com